



EUROFINS PRODUCT TESTING SERVICE (SHANGHAI) CO., LTD.

EMC TEST- REPORT

TEST REPORT NUMBER: EFSH15101363-IE-01-E01-A1



Eurofins Product Testing Service (Shanghai) Co., Ltd.
No.395 West Jiangchang Road, Jing'an District, Shanghai,
200436, P.R. China

Phone: +86-21-61819181
Fax: +86-21-61819180
Page 1 of 35

TABLE OF CONTENTS
1 Contents

| | | |
|----------|--|-----------|
| 1 | Contents | 2 |
| 2 | General Information | 3 |
| 2.1 | Notes | 3 |
| 2.2 | Testing laboratory | 4 |
| 2.3 | Details of approval holder | 5 |
| 2.4 | Application details | 5 |
| 2.5 | EUT Information | 5 |
| 2.6 | Test standards | 5 |
| 3 | Technical test | 6 |
| 3.1 | Summary of test results | 6 |
| 3.2 | Test environment | 6 |
| 3.3 | Test equipment utilized | 7 |
| 3.4 | Test results | 8 |
| 4 | Emission Test | 9 |
| 4.1 | Conducted Emission | 9 |
| 4.2 | Disturbance power | 12 |
| 4.3 | Radiated disturbance | 15 |
| 4.4 | Voltage Changes, Voltage Fluctuations and Flicker | 18 |
| 5 | Immunity Test | 20 |
| 5.1 | Performance Criteria Description in Clause 6 of EN 55014-2 | 20 |
| 5.2 | Classification of apparatus | 20 |
| 5.3 | ESD | 21 |
| 5.4 | Radio frequency electromagnetic fields | 22 |
| 5.5 | Electrical Fast Transients | 23 |
| 5.6 | Surge Immunity | 24 |
| 5.7 | Injected currents(RF continues conducted) | 25 |
| 5.8 | Voltage dips and Interruption | 26 |
| 6 | Test Setup Photos | 27 |
| 7 | EUT Photos | 31 |
| 8 | Amendment 1 | 35 |

2 General Information

2.1 Notes

The results of this test report relate exclusively to the item tested as specified in chapter "Description of test item" and are not transferable to any other test items.

Eurofins Product Testing Service (Shanghai) Co., Ltd. is not responsible for any generalisations and conclusions drawn from this report. Any modification of the test item can lead to invalidity of test results and this test report may therefore be not applicable to the modified test item.

The test report may only be reproduced or published in full. Reproducing or publishing extracts of the report requires the prior written approval of the Eurofins Product Testing Service (Shanghai) Co., Ltd.

This document is subject to the General Terms and Conditions and the Testing and Certification System of Eurofins Product Testing Service (Shanghai) Co., Ltd., available on request or accessible at www.pt.eurofins.com.

Operator:

| | | | |
|------------|---------------|-----------------------------|---|
| 2018-06-19 | | Perry Li / Testing Engineer |  |
| _____ | _____ | _____ | _____ |
| Date | Eurofins-Lab. | Name / Title | Signature |

Technical responsibility for area of testing:

| | | | |
|------------|----------|--------------------------------|--|
| 2018-06-19 | | Stefan Zhao / Project Engineer |  |
| _____ | _____ | _____ | _____ |
| Date | Eurofins | Name / Title | Signature |

Test Report No.: EFSH15101363-IE-01-E01-A1

Eurofins Product Testing Service (Shanghai) Co., Ltd.
No.395 West Jiangchang Road, Jing'an District, Shanghai, 200436, P.R. China

2.2 Testing laboratory

Eurofins Product Testing Service (Shanghai) Co., Ltd.

No.395 West Jiangchang Road, Jing'an District, Shanghai, 200436, P.R. China

Telephone : +86-21-61819181

Telefax : +86-21-61819180

Test location, where different:

Subcontractor

Name : BUREAU VERITAS ADT (SHANGHAI) CORPORATION.
Address : 2F, Building C, No. 1618 Yishan Road SHANGHAI
Telephone : + 86-21-6465 9091
Fax : + 86-21-6465 9092

Radiated emission test was performed by Stefan Zhao at BUREAU VERITAS ADT (SHANGHAI) CORPORATION.

Subcontractor

Name : Shanghai Morlab Communications Technology Co., Ltd.
Address : 3/F., Building 1, No.1399, Jianguyue Road, Minhang District, Shanghai, China
Telephone : +86-21-51089899
Fax : ./.

Radiated immunity test was performed at Shanghai Morlab Communications Technology Co., Ltd.

2.3 Details of approval holder

Name :
Address :
Telephone :
Fax :

| | |
|--|--|
| | |
|--|--|

2.4 Application details

Date of receipt of application : 2015-10-26
Date of receipt of test item : 2015-10-27
Date of test : 2015-10-27 to 2015-11-07
Amendment 1 : 2018-06-19 (Date of test: 2018-06-05 to 2018-06-15)

2.5 EUT Information

Product type : Hair Clipper
Model name : JD-510, JD-512
Brand name : ./.
Serial number : ./.
Ratings : 1,2 V d.c., Class III
Additional information :

The appliances covered by this report are hand-held rechargeable hair clippers with adaptor for household indoor use only.

JD-510 and JD-512 are identical except for different model name.

Both models incorporates an adaptor CL-201 (input: 230 V, 50 Hz; output: 1,5 V d.c., 300 mA).

After review, JD-510 with adaptor was tested and the most unfavourable results were recorded.

See page 35 for Amendment 1.

2.6 Test standards

EN 55014-1:2017

EN 55014-2:2015

EN 61000-3-2:2014

EN 61000-3-3:2013

3 Technical test

3.1 Summary of test results

No deviations from the technical specification(s) were ascertained in the course of the tests performed.



or

The deviations as specified were ascertained in the course of the tests performed.



3.2 Test environment

Eurofins Product Testing Service (Shanghai) Co., Ltd.

Temperature : 20 ... 25°C
Relative humidity content : 30 ... 60%
Air pressure : 100 ... 103kPa

BUREAU VERITAS ADT (SHANGHAI) CORPORATION.

Temperature : 24°C
Relative humidity content : 41%
Air pressure : 101kPa

Shanghai Morlab Communications Technology Co., Ltd.

Temperature : 26°C
Relative humidity content : 46%
Air pressure : 101kPa

3.3 Test equipment utilized

| Measurement Equipment List | | | | |
|----------------------------|---|-------------|------------------------|---------------|
| No. | Name | Model | Manufacturer | Cal. due date |
| 1 | EMI test receiver | ESCI | R&S | 2015-11-27 |
| 2 | Single phase Harmonics & Flicker analyser | PACS-1 | California Instruments | 2015-11-27 |
| 3 | AC Power Source | 5001ix | California Instruments | 2015-11-27 |
| 4 | Coupling/Decoupling Network | L 801 M2/M3 | Luethi | 2015-11-27 |
| 5 | Ultra Compact Simulator | UCS 500N7 | EMTEST | 2015-11-27 |
| 6 | ESD Gun | NSG 437 | TESEQ | 2015-11-27 |
| 7 | Current transformer | MC2630 | EMTEST | 2015-11-27 |
| 8 | Motorized variac | MV2616 | EMTEST | 2015-11-27 |
| 9 | Continuous wave simulator | CWS500N1 | EMTEST | 2015-11-27 |
| 10 | Magnetic field coil | MS100 | EMTEST | 2015-11-27 |
| 11 | Current transformer | MC26100 | EMTEST | 2015-11-27 |
| 12 | Artificial mains | ENV216 | R&S | 2015-11-27 |
| 13 | EMI Test Spectrum | E4403B | Agilent | 2016-08-24 |
| 14 | EMI test receiver | ESCS30 | R&S | 2016-04-13 |
| 15 | Broadband Antenna | VULB9168 | Schwarzbeck | 2016-03-26 |
| 16 | Amplifier | 8447D | Agilent | 2016-11-06 |

Shanghai Morlab Communications Technology Co., Ltd.

| | | | | |
|----|-------------------------------|--------------|-------------|------------|
| 20 | Radiated immunity test system | ITS 6006 | TESEQ | 2019-01-26 |
| 21 | Power meter | PMR 6006 | TESEQ | 2019-01-26 |
| 22 | Power Amplifier | 80RF1000-500 | MILMEGA | 2019-04-11 |
| 23 | Log-periodic Antenna | STLP 9218 D | Schwarzbeck | 2018-07-24 |

3.4 Test results

 1st test

 test after modification

 production test

| Test case | Subclause | Required | Test passed | Test failed |
|---|--|-------------------------------------|-------------------------------------|--------------------------|
| Conducted Emission | Clause 4.3.3 of EN 55014-1 | <input checked="" type="checkbox"/> | <input checked="" type="checkbox"/> | <input type="checkbox"/> |
| Disturbance power | Clause 4.3.4.4 of EN 55014-1 | <input checked="" type="checkbox"/> | <input checked="" type="checkbox"/> | <input type="checkbox"/> |
| Radiated disturbance | Clause 4.3.4.5 of EN 55014-1 | <input checked="" type="checkbox"/> | <input checked="" type="checkbox"/> | <input type="checkbox"/> |
| Discontinuous disturbance | Clause 4.4 of EN 55014-1 | <input type="checkbox"/> | <input type="checkbox"/> | <input type="checkbox"/> |
| Harmonic Current Emissions | EN 61000-3-2 | <input type="checkbox"/> | <input type="checkbox"/> | <input type="checkbox"/> |
| Voltage Changes, Voltage Fluctuations and Flicker | EN 61000-3-3 | <input checked="" type="checkbox"/> | <input checked="" type="checkbox"/> | <input type="checkbox"/> |
| Electrostatic Discharge | Clause 5.1 of EN 55014-2 & IEC 61000-4-2 | <input checked="" type="checkbox"/> | <input checked="" type="checkbox"/> | <input type="checkbox"/> |
| Electrical Fast Transients | Clause 5.2 of EN 55014-2 & IEC 61000-4-4 | <input checked="" type="checkbox"/> | <input checked="" type="checkbox"/> | <input type="checkbox"/> |
| Injected currents (RF continues conducted) | Clause 5.3 & 5.4 of EN 55014-2 & IEC 61000-4-6 | <input checked="" type="checkbox"/> | <input checked="" type="checkbox"/> | <input type="checkbox"/> |
| Radio frequency electromagnetic fields | Clause 5.5 of EN 55014-2 & IEC 61000-4-3 | <input checked="" type="checkbox"/> | <input checked="" type="checkbox"/> | <input type="checkbox"/> |
| Surge immunity | Clause 5.6 of EN 55014-2 & IEC 61000-4-5 | <input checked="" type="checkbox"/> | <input checked="" type="checkbox"/> | <input type="checkbox"/> |
| Voltage dips and Interruption | Clause 5.7 of EN 55014-2 & IEC 61000-4-11 | <input checked="" type="checkbox"/> | <input checked="" type="checkbox"/> | <input type="checkbox"/> |

Note 1: The additional margin(0 to 10dB) was meet in the frequency range 200MHz to 300MHz in Disturbance power test(absorbing clamp), and the EUT did not contained any circuit with clock frequency more than 30MHz, so the EUT was compliant with the Radiated disturbance test (300MHz-1GHz) without test.(charging condition)

Note 2: The click rate was less than 5, and the click duration was less than 10ms. So it is deemed to comply with Discontinuous disturbance test.

Note 3: The Harmonic Current Emissions test was not required as the EUT with a rated power of 75W or less (charging condition).

Test Report No.: EFSH15101363-IE-01-E01-A1

Eurofins Product Testing Service (Shanghai) Co., Ltd.
No.395 West Jiangchang Road, Jing'an District, Shanghai, 200436, P.R. China

4 Emission Test

4.1 Conducted Emission

This clause lays down the general requirements for the measurement of disturbance voltage produced at the terminals of apparatus.

4.1.1 Limits

| Frequency range MHz | At mains terminals dB (μ V) | |
|------------------------|-------------------------------------|---------------|
| | Quasi-peak Limit | Average Limit |
| 0.15 to 0.50 | 66 to 56 | 59 to 46 |
| 0.50 to 5 | 56 | 46 |
| 5 to 30 | 60 | 50 |

Note1: The limit decreases linearly with the logarithm of the frequency in the range 0.15 MHz to 30 MHz.

Note2: The lower limit is applicable at the transition frequency.

4.1.2 Measurement procedure

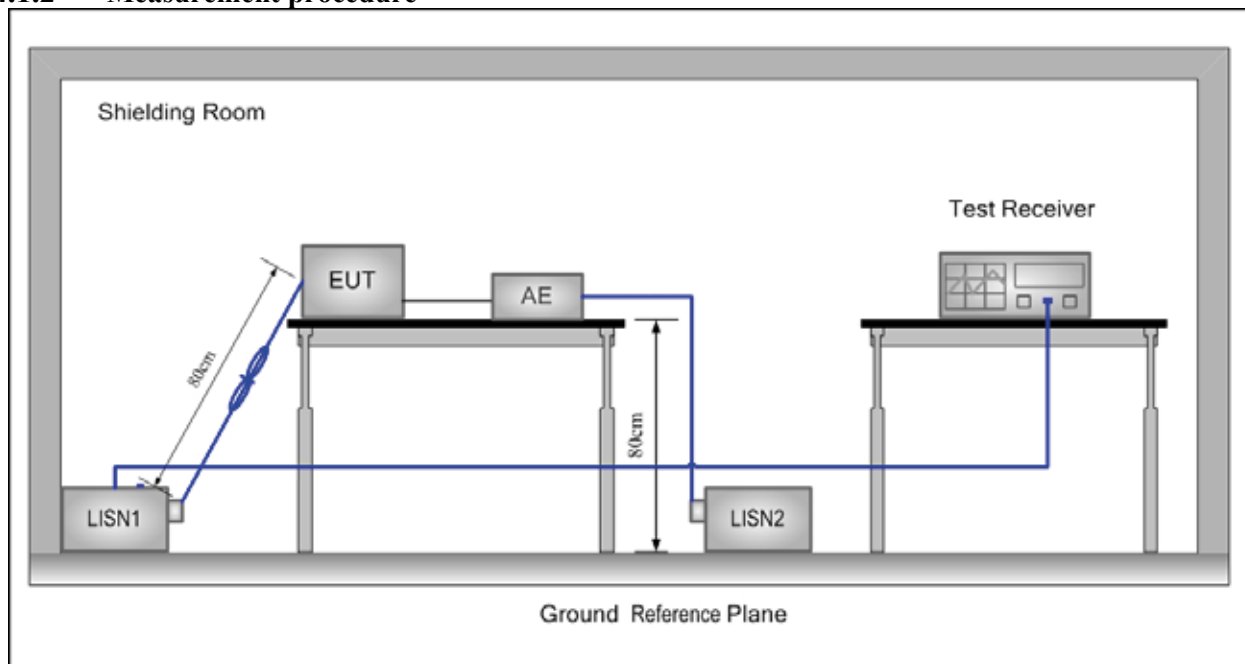

1. The mains terminal disturbance voltage was measured with the EUT in a shielded room.
2. The EUT was connected to AC power source through a LISN (Line Impedance Stabilization Network) which provides a $(50 \mu\text{H} + 5 \Omega) \parallel 50 \Omega$ linear impedance. The power cables of all other units of the EUT were connected to a second LISN, which was bonded to the ground reference plane in the same way as the LISN for the unit being measured.
3. The tabletop EUT was placed upon a non-metallic table 0.8m above the ground reference plane. And for floor-standing arrangement, the EUT was placed on the horizontal ground reference plane, but separated from metallic contact with the ground reference plane by 0.1m of insulation.

Test Report No.: EFSH15101363-IE-01-E01-A1

Eurofins Product Testing Service (Shanghai) Co., Ltd.
No.395 West Jiangchang Road, Jing'an District, Shanghai, 200436, P.R. China

4. According to a pre-test at 160kHz, the worst voltage was selected for final test. Before get the final emission results with quasi-peak(QP) detector and average(AVG) detector, a pre-scan was performed with the peak(PK) and average(AVG) detector to find out the maximum emission data plots of the EUT.

4.1.3 Measurement uncertainty

$U_{lab}(cond) = 1.8dB$ at 95% level of confidence, $k=2$

4.1.4 Results -Measurement Data

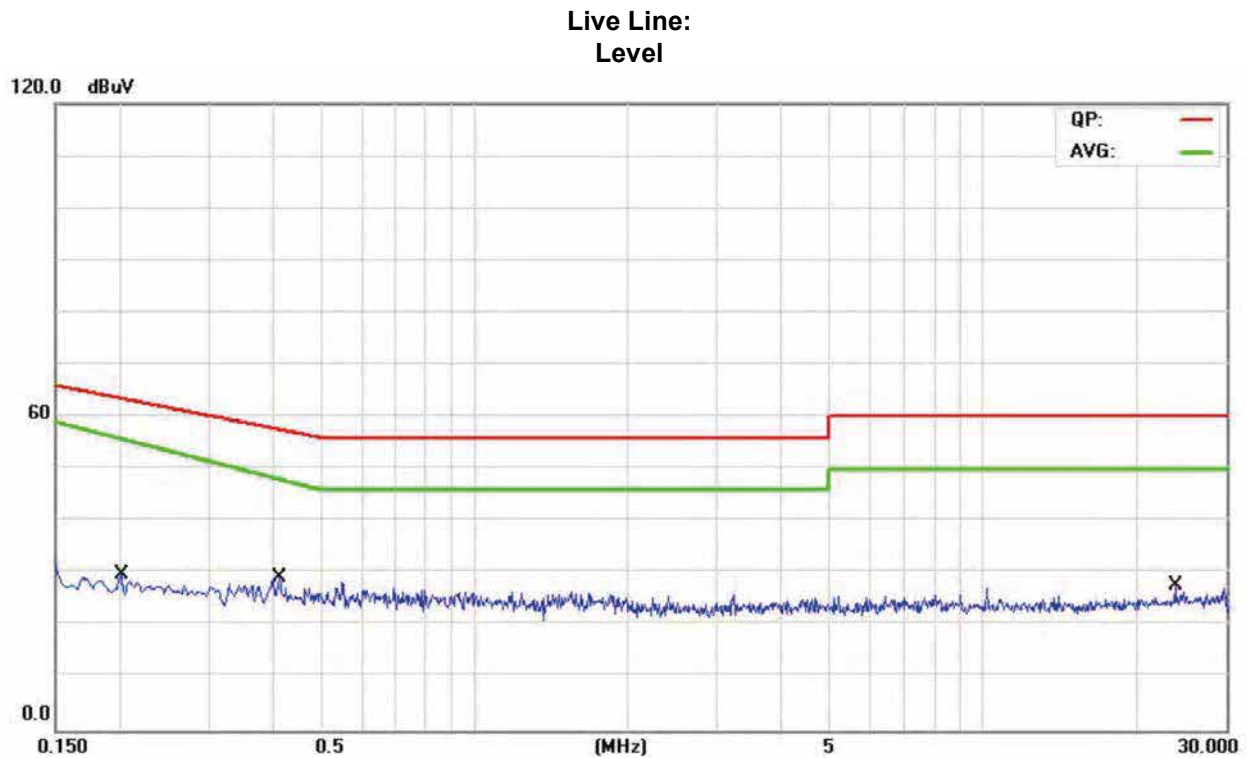

| No. Mk. | Freq. MHz | Reading Level dBuV | Correct Factor dB | Measure- ment dBuV | Limit dBuV | Over dB | Detector |
|---------|--------------|--------------------------|-------------------------|--------------------------|---------------|------------|----------|
| 1 | 0.2020 | 13.05 | 9.87 | 22.92 | 63.53 | -40.61 | QP |
| 2 | 0.2020 | 9.16 | 9.87 | 19.03 | 55.79 | -36.76 | AVG |
| 3 | 0.4140 | 11.05 | 9.76 | 20.81 | 57.57 | -36.76 | QP |
| 4 * | 0.4140 | 7.59 | 9.76 | 17.35 | 48.04 | -30.69 | AVG |
| 5 | 23.7940 | 8.31 | 10.44 | 18.75 | 60.00 | -41.25 | QP |
| 6 | 23.7940 | 3.75 | 10.44 | 14.19 | 50.00 | -35.81 | AVG |

Neutral Line:
Level

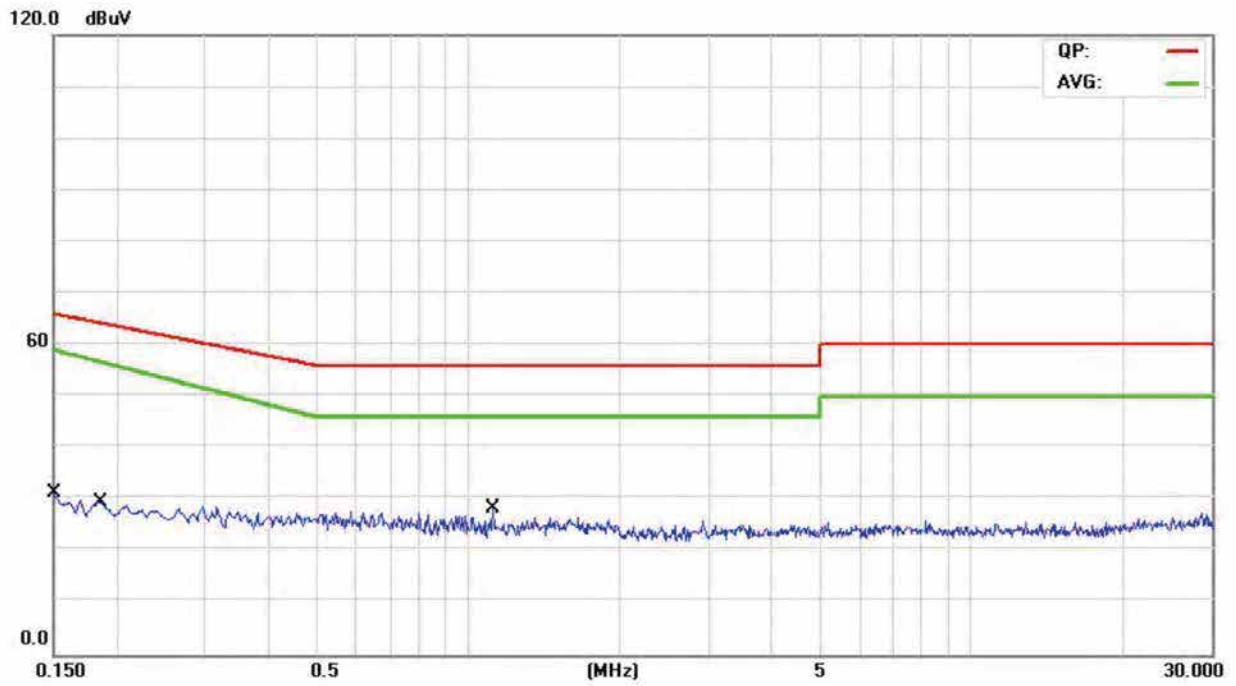

| No. Mk. | Freq. MHz | Reading Level dBuV | Correct Factor dB | Measure- ment dBuV | Limit dBuV | Over dB | Detector |
|---------|--------------|--------------------------|-------------------------|--------------------------|---------------|------------|----------|
| 1 | 0.1500 | 15.97 | 10.18 | 26.15 | 66.00 | -39.85 | QP |
| 2 | 0.1500 | 11.16 | 10.18 | 21.34 | 59.00 | -37.66 | AVG |
| 3 | 0.1874 | 13.59 | 9.95 | 23.54 | 64.15 | -40.61 | QP |
| 4 | 0.1874 | 9.50 | 9.95 | 19.45 | 56.60 | -37.15 | AVG |
| 5 | 1.1220 | 9.28 | 9.68 | 18.96 | 56.00 | -37.04 | QP |
| 6 * | 1.1220 | 6.10 | 9.68 | 15.78 | 46.00 | -30.22 | AVG |

4.2 Disturbance power

This clause lays down the general requirements for the measurement of disturbance power produced at the terminals of apparatus.

4.2.1 limits

| Frequency range MHz | Limit dB (pW) | |
|---|------------------|----------|
| | Quasi-peak | Average |
| 30 to 300 | 45 to 55 | 35 to 45 |
| Note1: Increasing linearly with the frequency from. | | |

4.2.2 Measurement procedure

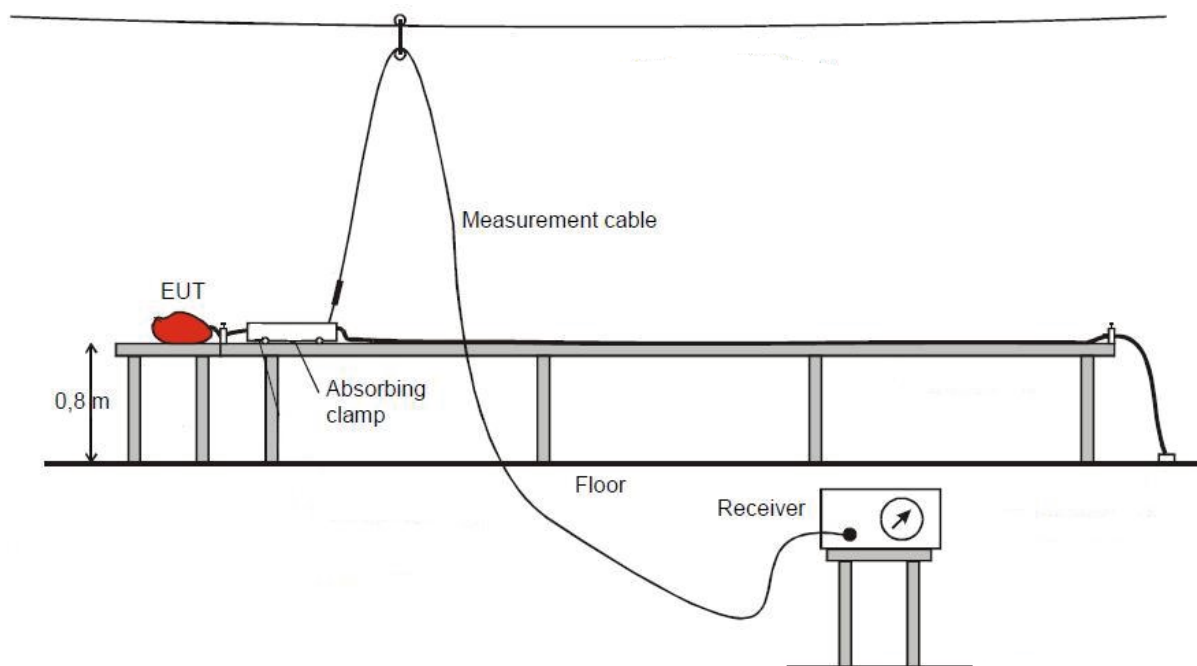

The test configuration corresponds to the standard EN 55014-1. The equipment under test is placed on a non metallic table with 0,8 m high. The lead to be measured is stretched horizontally in a straight line, to permit variation in position of the absorbing clamp along the lead to find the maximum indication. The lead shall be at least length of 6 meter. According to a pre-test at 50MHz, the worst voltage was selected for final test. Before get the final emission results with quasi-peak(QP) detector and average(AVG) detector, a pre-scan was performed with the peak(PK) detector to find out the maximum emission data plots of the EUT. The absorbing clamp is placed around the lead.

4.2.3 Measurement uncertainty

$U_{lab}(cond) = 3.35 \text{ dB}$ at confidence of 95%, $k=2$

4.2.4 Results

AC Line Level

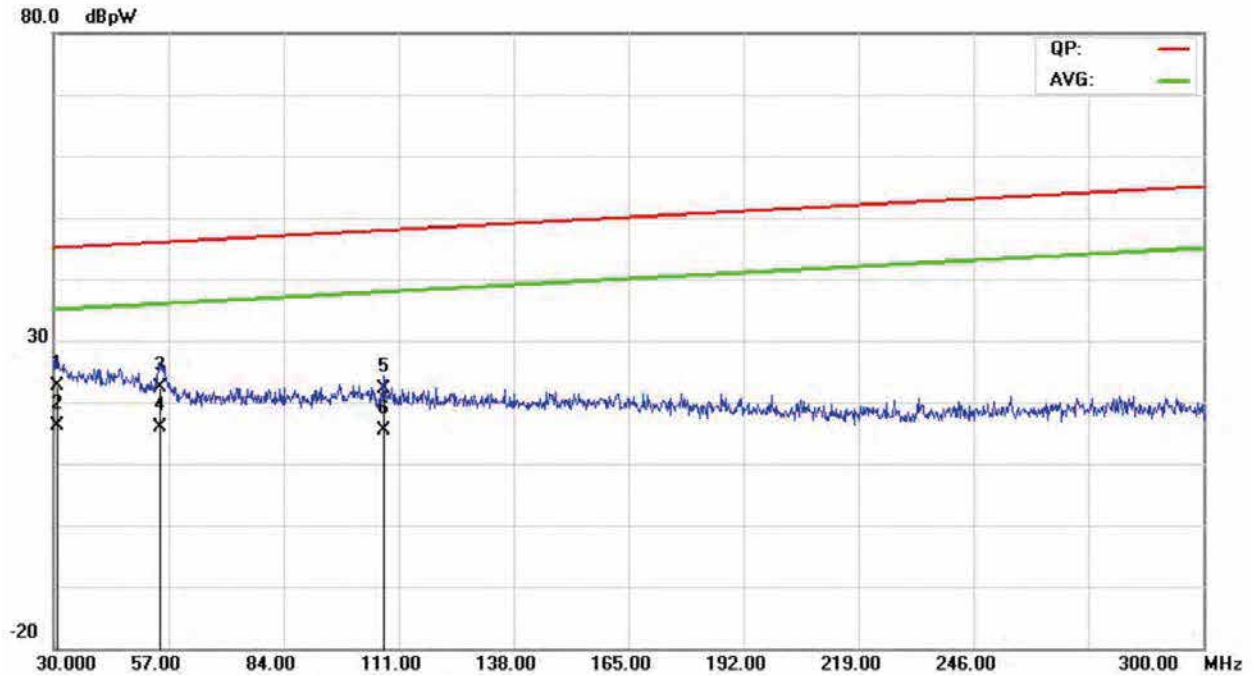

| No. | Mk. | Freq. MHz | Reading Level dBpW | Correct Factor dB | Measure- ment dBpW | Limit dBpW | Over dB | Detector |
|-----|-----|--------------|--------------------------|-------------------------|--------------------------|---------------|------------|----------|
| 1 | | 30.8400 | -3.35 | 26.01 | 22.66 | 45.03 | -22.37 | QP |
| 2 | * | 30.8400 | -9.91 | 26.01 | 16.10 | 35.03 | -18.93 | AVG |
| 3 | | 55.2400 | -0.09 | 22.36 | 22.27 | 45.93 | -23.66 | QP |
| 4 | | 55.2400 | -6.46 | 22.36 | 15.90 | 35.93 | -20.03 | AVG |
| 5 | | 107.6800 | 0.32 | 21.78 | 22.10 | 47.88 | -25.78 | QP |
| 6 | | 107.6800 | -6.28 | 21.78 | 15.50 | 37.88 | -22.38 | AVG |

DC Line Level

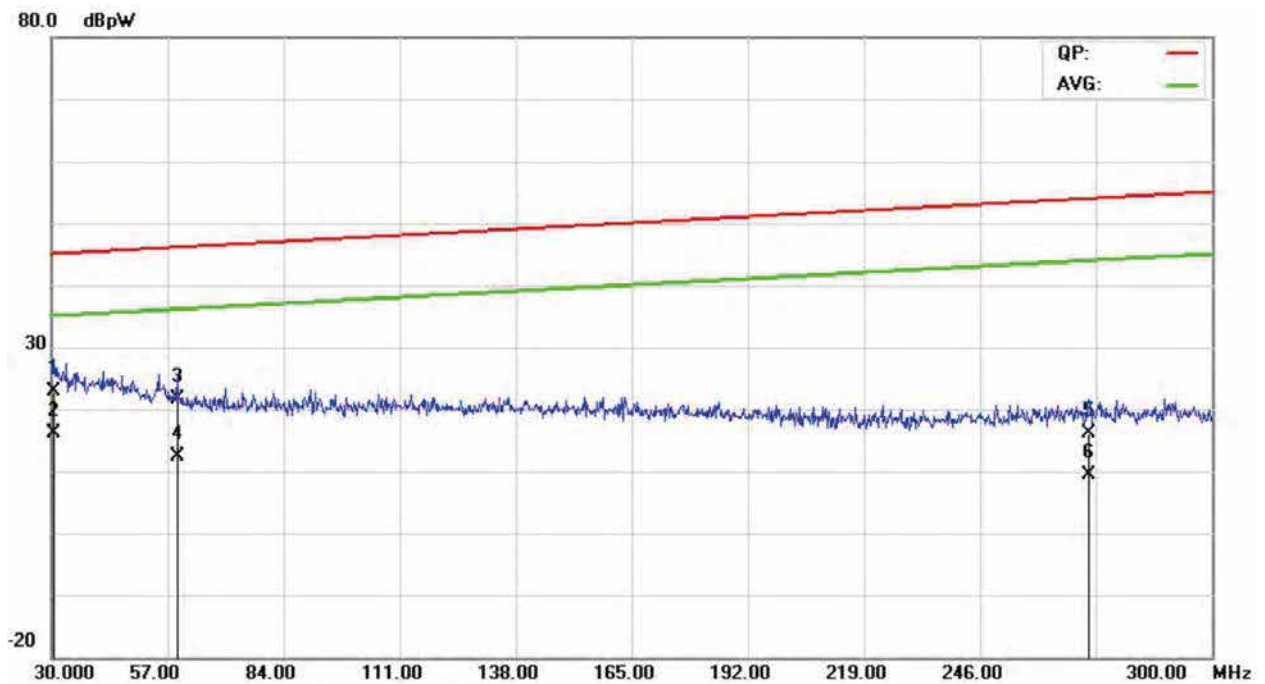

| No. | Mk. | Freq. MHz | Reading Level dBpW | Correct Factor dB | Measure- ment dBpW | Limit dBpW | Over dB | Detector |
|-----|-----|--------------|--------------------------|-------------------------|--------------------------|---------------|------------|----------|
| 1 | | 30.8000 | -3.16 | 26.01 | 22.85 | 45.03 | -22.18 | QP |
| 2 | * | 30.8000 | -9.81 | 26.01 | 16.20 | 35.03 | -18.83 | AVG |
| 3 | | 59.3200 | -0.16 | 21.86 | 21.70 | 46.09 | -24.39 | QP |
| 4 | | 59.3200 | -9.56 | 21.86 | 12.30 | 36.09 | -23.79 | AVG |
| 5 | | 271.6000 | -3.94 | 20.07 | 16.13 | 53.95 | -37.82 | QP |
| 6 | | 271.6000 | -10.57 | 20.07 | 9.50 | 43.95 | -34.45 | AVG |

4.3 Radiated disturbance

This clause lays down the general requirements for the measurement of Radiated disturbance produced at the space of apparatus.

4.3.1 Limits

| Frequency range | Quasi-peak limits at 10m | Quasi-peak limits at 3m |
|-----------------|-------------------------------|-------------------------------|
| MHz | dB ($\mu\text{V}/\text{m}$) | dB ($\mu\text{V}/\text{m}$) |
| 30 to 230 | 30 | 40 |
| 230 to 1000 | 37 | 47 |

At transitional frequencies the lower limit applies.

4.3.2 Measurement procedure

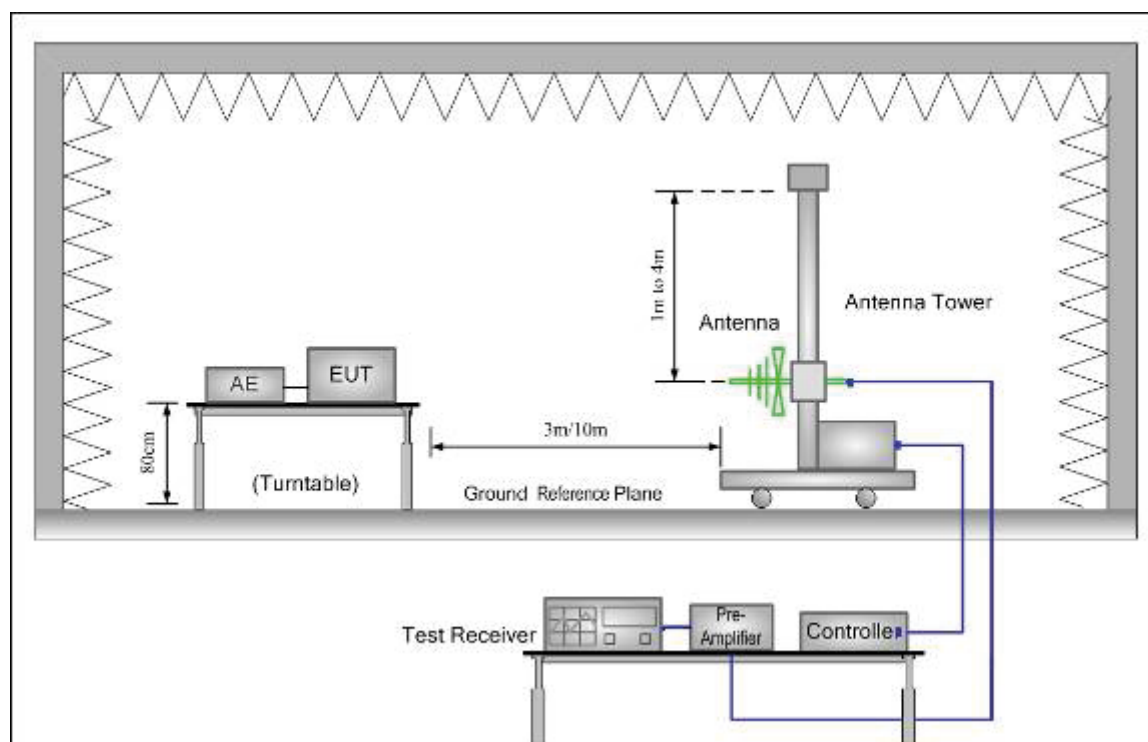

1. The radiated emissions test was conducted in a semi-anechoic chamber. The EUT was placed upon a non-metallic table 0.8m above the ground reference plane. And for floor-standing arrangement, the EUT was placed on the horizontal ground reference plane, but separated from metallic contact with the ground reference plane by 0.1m of insulation.
2. Before get the final emission results with quasi-peak(QP) detector, a pre-scan was performed with the peak(PK) detector to find out the maximum emission data plots of the EUT.
3. The frequencies of maximum emission were determined in the final radiated emissions measurement, the physical arrangement of the test system and associated cabling was varied in order to determine the effect on the EUT's emissions in amplitude, direction and frequency. At each frequency, the EUT was rotated 360°, and the antenna was raised and lowered from 1 to 4 meters in order to determine the maximum disturbance.

Measurements were performed for both horizontal and vertical antenna polarization. Test was performed on subcontractor.

4.3.3 Measurement uncertainty

$U_{lab}(cond) = 3.9dB$ at 95% level of confidence , $k=2$

4.3.4 Results

Note: Standalone operating mode as the worst mode to be recorded.

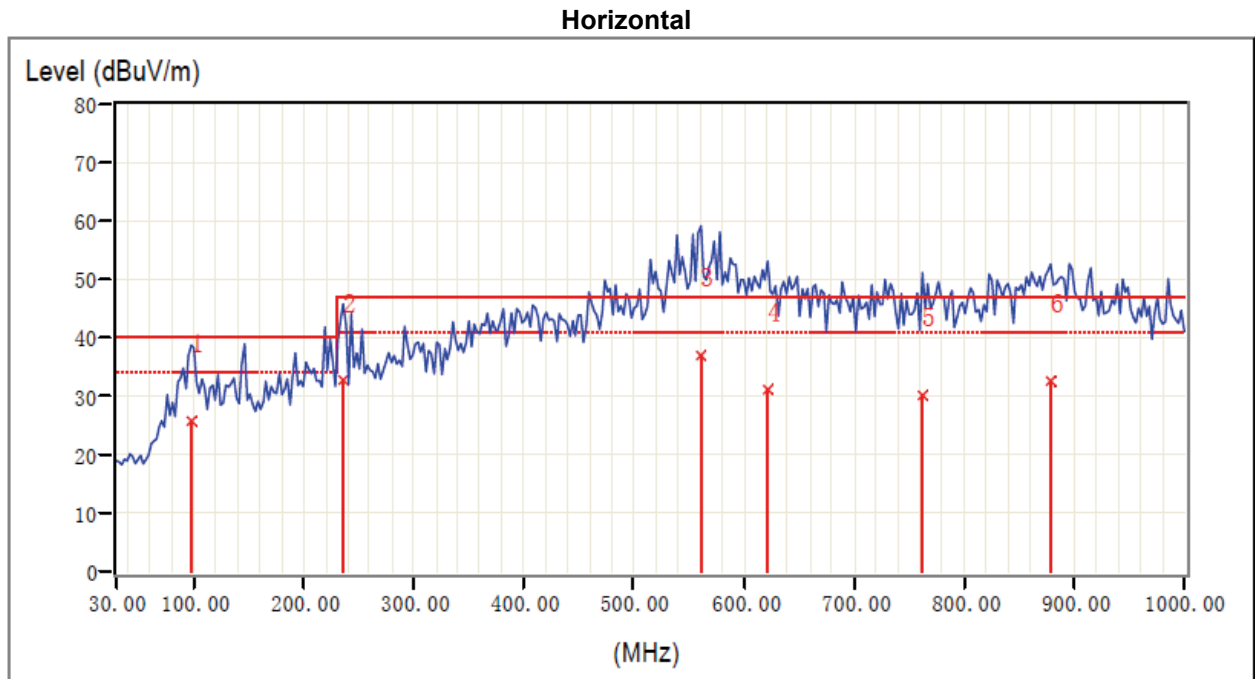

| No. | Frequency | Factor | Reading | Emission | Limit | Margin | Tower / Table | |
|-----|-----------|--------|---------|----------|-------|--------|---------------|--------|
| | MHz | | | | | | dB | dBuV/m |
| 1 | 97.90 | 10.40 | 15.30 | 25.70 | 40.00 | -14.30 | 200 | 100 |
| 2 | 236.12 | 11.92 | 20.81 | 32.73 | 47.00 | -14.27 | 200 | 105 |
| * | 561.08 | 21.35 | 15.58 | 36.93 | 47.00 | -10.07 | 120 | 93 |
| 4 | 621.70 | 22.88 | 8.21 | 31.09 | 47.00 | -15.91 | 196 | 310 |
| 5 | 762.35 | 25.35 | 4.76 | 30.11 | 47.00 | -16.89 | 157 | 105 |
| 6 | 878.75 | 26.62 | 5.95 | 32.57 | 47.00 | -14.43 | 200 | 130 |

Note:

1. All Readings below 1GHz are Quasi-Peak, above are performed with peak and/or average measurements as necessary.
2. Measurement Level = Reading Level + Factor(Probe+Cable).

Vertical

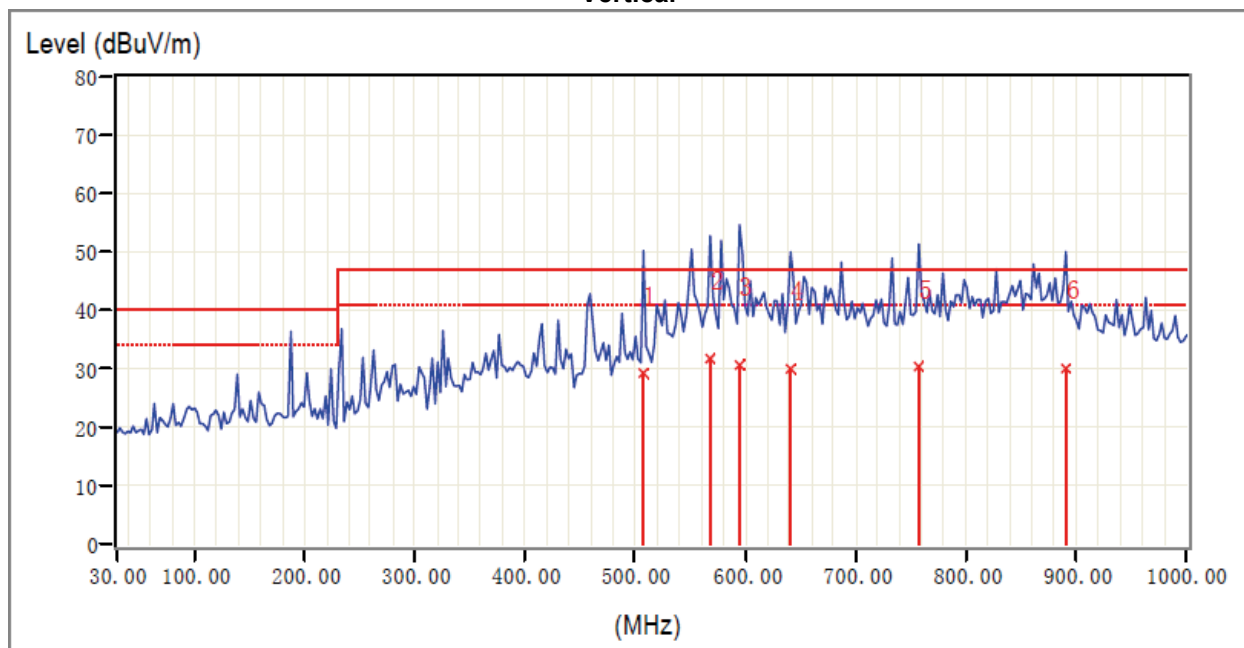

| No. | Frequency MHz | Factor dB | Reading dBuV/m | Emission dBuV/m | Limit dBuV/m | Margin dB | Tower / Table cm deg | |
|-----|------------------|--------------|-------------------|--------------------|-----------------|--------------|-------------------------|-----|
| 1 | 507.73 | 19.63 | 9.53 | 29.16 | 47.00 | -17.84 | 100 | 154 |
| * | 2 | 568.35 | 21.51 | 10.18 | 47.00 | -15.31 | 100 | 231 |
| 3 | 595.02 | 22.35 | 8.20 | 30.55 | 47.00 | -16.45 | 100 | 278 |
| 4 | 641.10 | 23.08 | 6.87 | 29.95 | 47.00 | -17.05 | 100 | 142 |
| 5 | 757.50 | 25.23 | 5.08 | 30.31 | 47.00 | -16.69 | 100 | 226 |
| 6 | 890.87 | 26.42 | 3.59 | 30.01 | 47.00 | -16.99 | 100 | 287 |

Note:

1. All Readings below 1GHz are Quasi-Peak, above are performed with peak and/or average measurements as necessary.
2. Measurement Level = Reading Level + Factor(Probe+Cable).

4.4 Voltage Changes, Voltage Fluctuations and Flicker

This part is concerned with the limitation of voltage fluctuations and flicker impressed on the public low-voltage system.

4.4.1 Limits

| Value | Limit |
|-------|-------|
| Pst | 1,0 |
| Plt | 0,65 |
| dt | 3,3% |
| dc | 3,3% |
| dmax | 4,0% |

4.4.2 Measurement test procedure

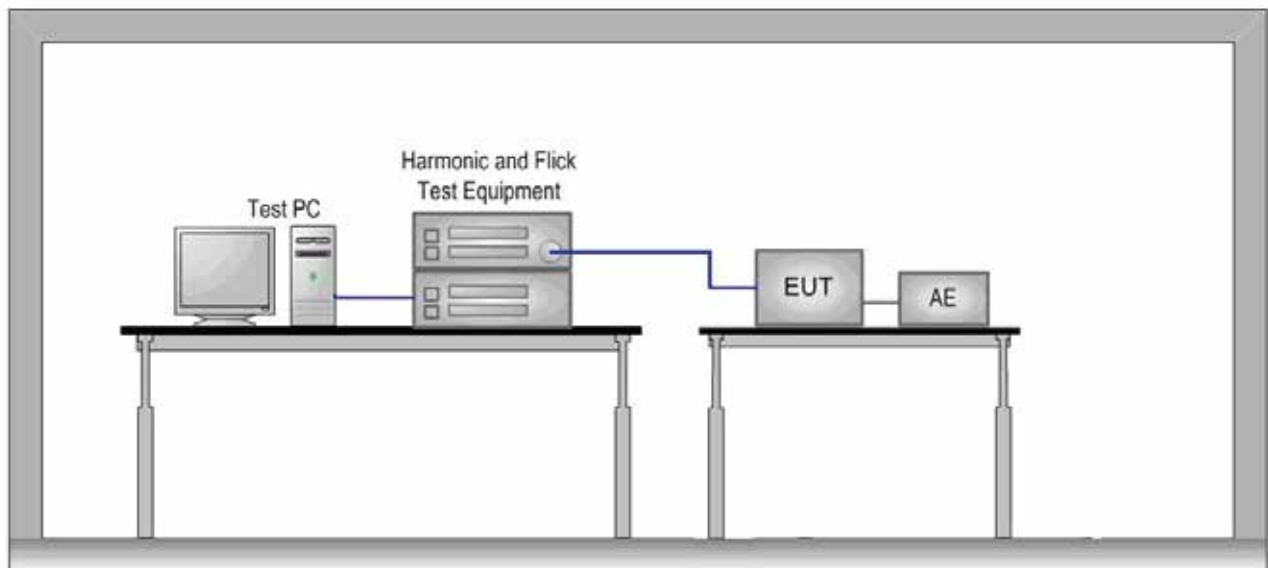

The equipment under test is placed on a wooden table with a height of 0,8 m in the EMC lab. The voltage fluctuations and flicker were measured at the supply terminals of the EUT.

4.4.3 Results

Parameter values recorded during the test:

| | | | |
|--|---------------|-------------------------|-------------------|
| Vrms at the end of test (Volt): | 229.97 | | |
| Highest dt (%): | 0.00 | Test limit (%): | 3.30 Pass |
| Time(mS) > dt: | 0.0 | Test limit (mS): | 500.0 Pass |
| Highest dc (%): | 0.00 | Test limit (%): | 3.30 Pass |
| Highest dmax (%): | 0.00 | Test limit (%): | 4.00 Pass |
| Highest Pst (10 min. period): | 0.064 | Test limit: | 1.000 Pass |

5 Immunity Test

5.1 Performance Criteria Description in Clause 6 of EN 55014-2

| | |
|---------------------|---|
| Criterion A: | The apparatus shall continue to operate as intended during the test. No degradation of performance or loss of function is allowed below a performance level (or permissible loss of performance) specified by the manufacturer, when the apparatus is used as intended. If the minimum performance level or the permissible performance loss is not specified by the manufacturer, then either of these may be derived from the product description and documentation, and from what the user may reasonably expect from the apparatus if used as intended. |
| Criterion B: | The apparatus shall continue to operate as intended after the test. No degradation of performance or loss of function is allowed below a performance level (or permissible loss of performance) specified by the manufacturer, when the apparatus is used as intended. During the test, degradation of performance is allowed, however. No change of actual operating state or stored data is allowed. If the minimum performance level or the permissible performance loss is not specified by the manufacturer, then either of these may be derived from the product description and documentation and from what the user may reasonably expect from the apparatus if used as intended. |
| Criterion C: | Temporary loss of function is allowed, provided the function is self recoverable or can be restored by the operation of the controls, or by any operation specified in the instructions for use. |

5.2 Classification of apparatus

| | |
|----------------------|---|
| Category I: | Apparatus containing no electronic control circuitry. |
| Category II: | Transformer toys, dual supply toys, mains powered motor operated appliances, tools, heating appliances and similar electric apparatus (for example . UV radiators, IR radiators and microwave ovens) containing electronic control circuitry with no internal clock frequency or oscillator frequency higher than 15 MHz. |
| Category III: | Equipment which in normal use, is not connected to a power network and has no cables attached. This category includes apparatus provided with rechargeable batteries, solar or other similar d.c. power sources which can be charged or operated by connecting the apparatus to the mains power. However, this apparatus shall also be tested as an apparatus in category II while it is connected to the mains network. |
| Category IV: | All other apparatus covered by the scope of this standard. |

The EUT belongs to Category III+ Category II (while connected to AC mains).

5.3 ESD

5.3.1 Test Procedures

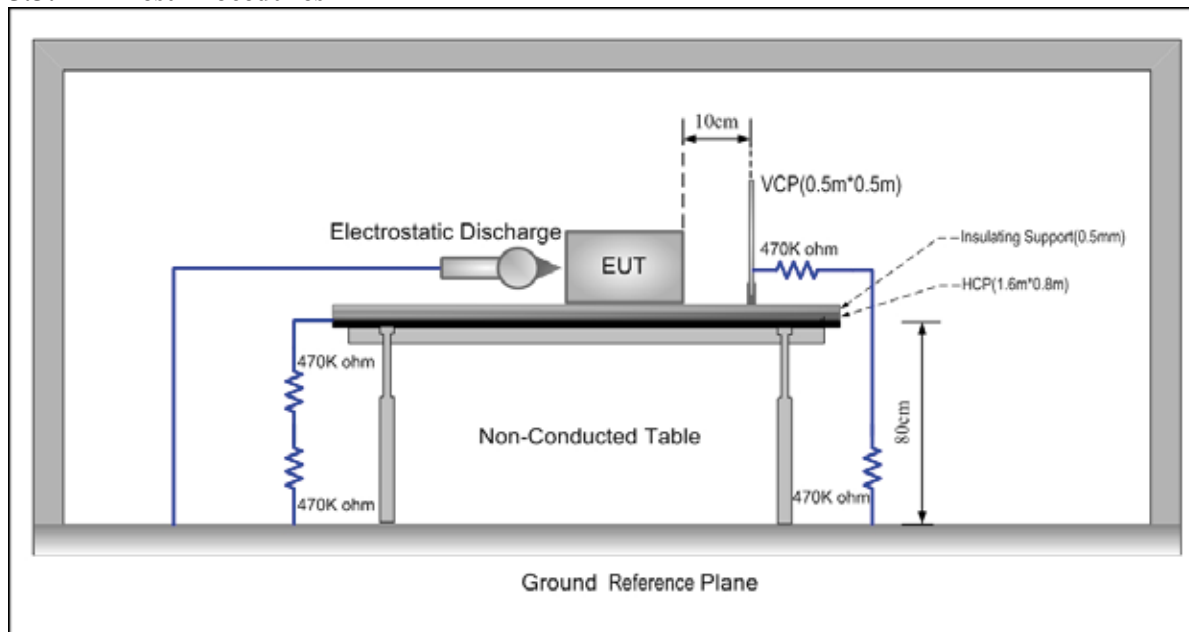

1. Contact discharge was applied only to conductive surfaces of the EUT. Air discharge was applied only to non-conducted surfaces of the EUT.
2. The EUT was put on a 0.8m high wooden table for table-top equipment or 0.1m high for floor standing equipment standing on the ground reference plane (GRP).
3. A horizontal coupling plane(HCP) 1.6m by 0.8m in size was placed on the table, and the EUT with its cables were isolated from the HCP by an insulating support thick than 0.5mm. The VCP 0.5m by 0.5m in size while HCP were constructed from the same material type and thickness as that of the GRP, and connected to the GRP via a 470kΩ resistor at each end. The distance between EUT and any of the other metallic surfaces excepted the GRP, HCP and VCP was greater than 1m.
4. During the contact discharges, the tip of the discharge electrode was touching the EUT before the discharge switch is operated. During the air discharges, the round discharge tip of the discharge electrode was approached as fast as possible to touch the EUT. After each discharge, the ESD generator was removed from the EUT, the generator is then retriggered for a new single discharge. For ungrounded product, a discharge cable with two resistances was used after each discharge to remove remnant electrostatic voltage. 10 times of each polarity single discharge were applied to HCP and VCP.

5.3.2 Results

| Test point | Table (T) Floor (F) | Contact (C) Air (A) | Voltage (kV) | Number of discharge | Polarity (+ / -) | Opinion |
|-------------------|------------------------|------------------------|-----------------|------------------------|---------------------|---------|
| Air discharge | T | A | 8 | 20 | + / - | A |
| Contact discharge | T | C | 4 | 20 | + / - | A |
| HCP | T | C | 4 | 20 | + / - | A |
| VCP | T | C | 4 | 20 | + / - | A |

A: no loss of function.

5.4 Radio frequency electromagnetic fields

5.4.1 Measurement procedure

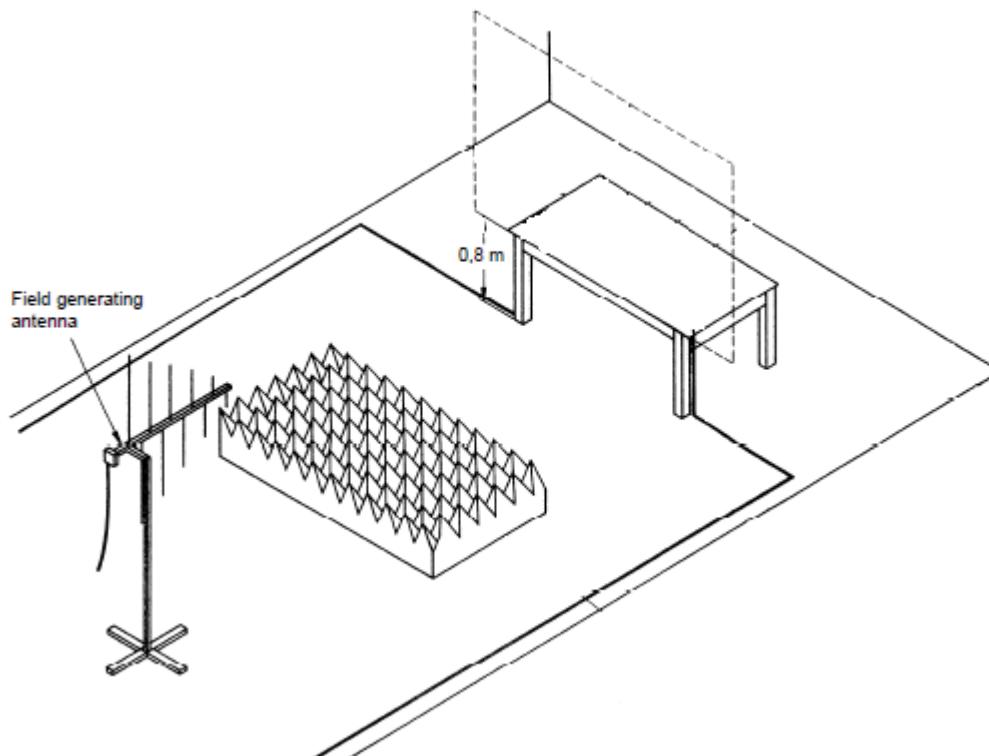

- 1 The EUT was placed on 0.8m high wooden table for table-top equipment. For floor standing equipment, the EUT was placed on a 0.1m high wooden support above the GRP. The tests normally shall be performed with the generating antenna facing each of four sides of the EUT. When equipment can be used in different orientations (e.g. vertical or horizontal) the test shall be performed on all possible sides of the EUT.
- 2 The tests are carried out with a field strength by 3 V/m (measured in the unmodulated field) with amplitude modulated signal by a depth of 80 % by a sinusoidal audio signal of 1 kHz. The logarithmic step was 1% and the dwell time was 3s dependent of the EUT cycle time.
- 3 The EUT shall be positioned so that the four sides of the EUT shall be exposed to the electromagnetic field in sequence. In each position the performance of the EUT will be investigated. In the case where the most sensitive surface side of the EUT is known throughout the frequency range (for example, via preliminary tests), testing may be restricted to that surface side only. Test was performed on subcontractor.

5.4.2 Results

For standalone operating mode:

| Frequency Range | Field Strength | Modulation | Opinion |
|-----------------|----------------|-------------|---------|
| 80MHz to 1GHz | 3V/m | 80% AM 1kHz | A |

A: no loss of function.

5.5 Electrical Fast Transients

5.5.1 Measurement procedure

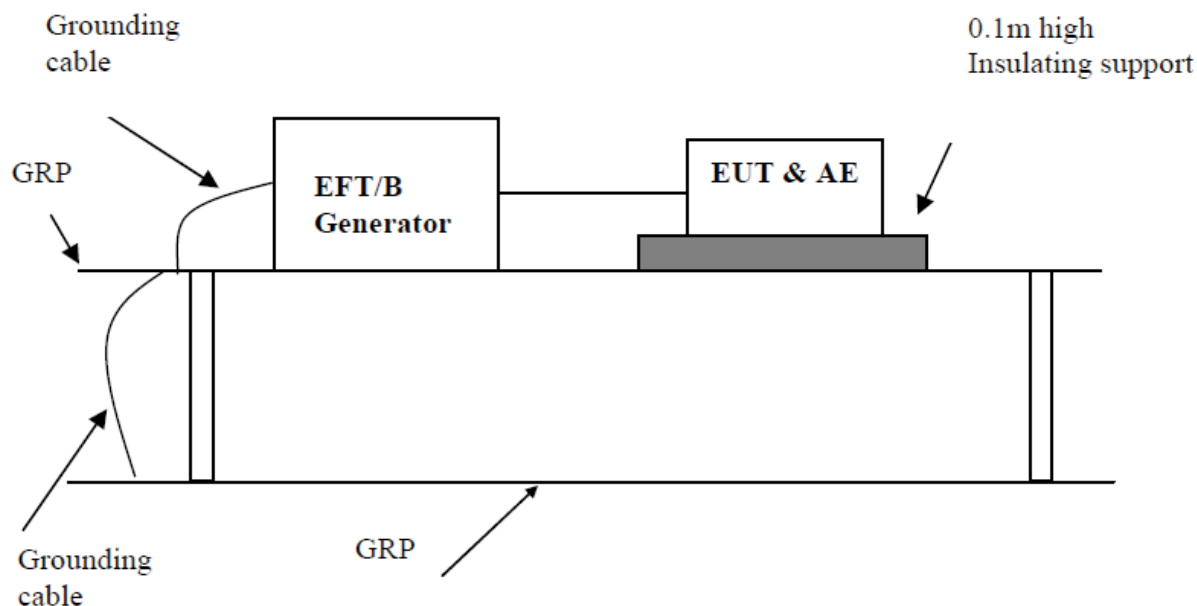

1. The EUT was placed on a ground reference plane (GRP) insulated by an insulating support 0.1 m thick and the GRP was placed on a 0.8m high wooden table for table-top equipment. For floor standing equipment, the EUT was placed on a 0.1m high wooden support above the GRP.
2. The GRP shall project beyond the EUT and the clamp by at least 0.1m on all sides. The distance between the EUT and any other of the metallic surface except the GRP was greater than 0.5m. All cables to the EUT was placed on the insulation support 0.1m above GRP. Cables not subject to EFT was routed as far as possible from cable under test to minimize the coupling between the cables.
3. The length of signal and power cable between the EUT and EFT generator was 0.5m. If the cable is a non-detachable supply cable more than 0.5m, the excess length of this cable shall be folded to avoid a flat coil and situated at a distance of 0.1m above the GRP.

5.5.2 Results

| Test port | Voltage (kV) | Polarity (+ / -) | Duration (s or min) | Waveform Tr / Th | Repetition Frequency (kHz) | Opinion |
|---------------|--------------|------------------|---------------------|------------------|----------------------------|---------|
| AC power line | 1 | + / - | 2 min | 5/50 ns | 5 | A |

A: no loss of function.

5.6 Surge Immunity

5.6.1 Measurement procedure

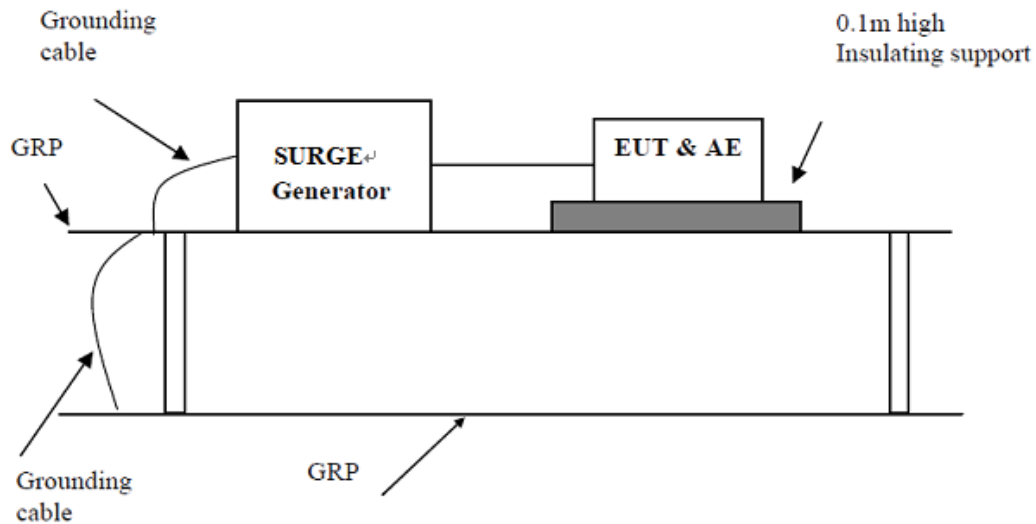

1. The EUT was placed on a ground reference plane (GRP) insulated by an insulating support 0,1 m thick and the GRP was placed on a 0.8m high wooden table for table-top equipment. For floor standing equipment, the EUT was placed on a 0.1m high wooden support above the GRP.
2. The 1,2/50 μ s surge was to be applied to the EUT power supply terminals via the capacitive coupling network. Decoupling networks were required in order to avoid possible adverse effects on equipment not under test that may be powered by the same lines and to provide sufficient decoupling impedance to the surge wave so that the specified wave may be applied on the lines under test.
3. The positive pulses are applied 90° relative to the phase angle of the a.c. line voltage to the equipment under test, and the negative pulses are applied 270° relative to the phase angle of the a.c. line voltage to the equipment under test.

5.6.2 Results

| Test mode | Polarity (+ / -) | Voltage (kV) | Waveform Tr / Th | Number of pulses | Opinion |
|--------------|------------------|--------------|------------------|------------------|---------|
| Live-Neutral | + / - | 0.5/1 | 1.2/50 μ s | 5 | A |

A: no loss of function.

5.7 Injected currents(RF continues conducted)

5.7.1 Measurement procedure

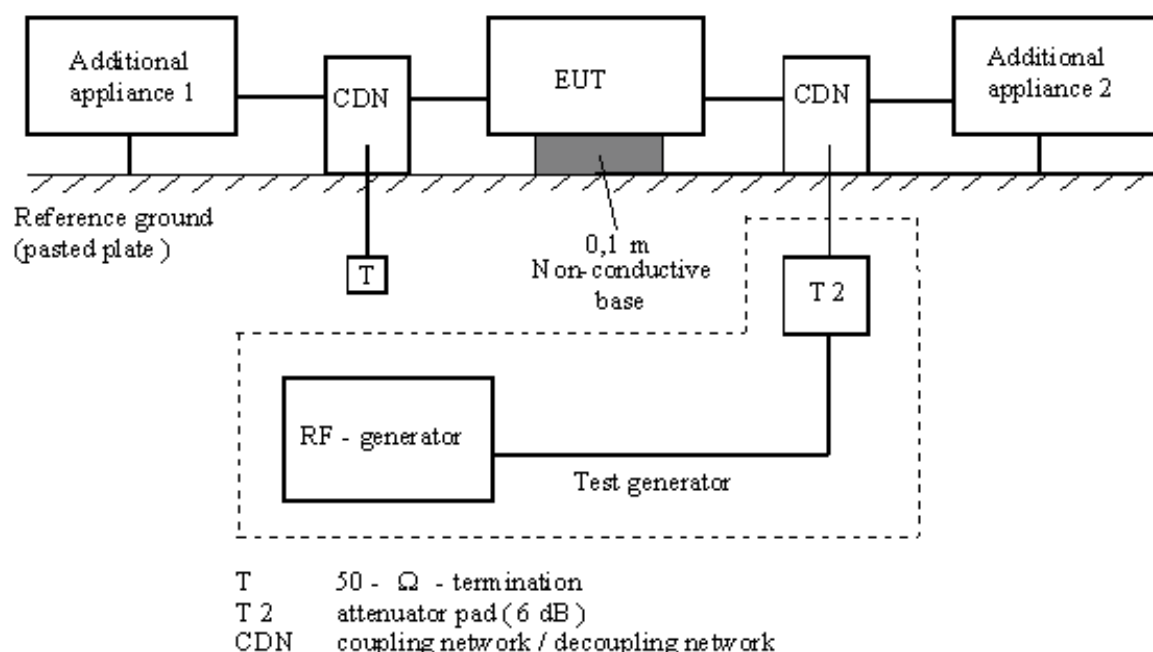

1. The EUT was placed on an insulating support of 0.1m height above a ground reference Plane, arranged and connected to satisfy its functional requirement. All cables exiting the EUT was supported at a height of at least 30 mm above the ground reference plane.
2. The coupling and decoupling devices were required, they were located between 0,1 m and 0,3 m from the EUT. This distance was to be measured horizontally from the projection of the EUT on to the ground reference plane to the coupling and decoupling device.
3. The frequency range was swept from 150 kHz to 230 MHz, using the signal levels established during the setting process, and with the disturbance signal 80 % amplitude modulated with a 1 kHz sine wave, pausing to adjust the RF signal level or to change coupling devices as necessary. Where the frequency was swept incrementally, the step size do not exceed 1 % of the preceding frequency value. The dwell time of the amplitude modulated carrier at each frequency was not less than the time necessary for the EUT to be exercised and to respond, and was not less than 3s.

5.7.2 Results

| Test port | Voltage (e.m.f.) | Modulation | Frequency Range | Opinion |
|---------------|------------------|--------------|-------------------|---------|
| AC power line | 3V | 80% AM 1 kHz | 150 kHz - 230 MHz | A |

A: no loss of function.

5.8 Voltage dips and Interruption

5.8.1 Measurement procedure

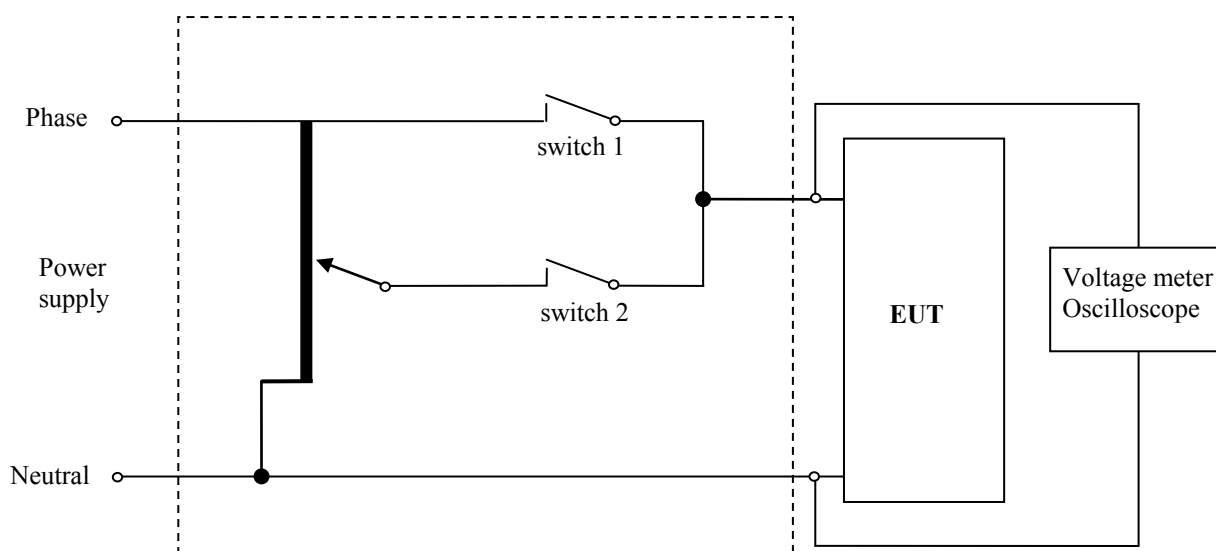

1. The EUT was placed on a ground reference plane (GRP) insulated by an insulating support 0,1 m thick and the GRP was placed on a 0.8m high wooden table for table-top equipment. For floor standing equipment, the EUT was placed on a 0.1m high wooden support above the GRP.
2. The test was performed with the EUT connected to the test generator with the shortest power supply cable as specified by the EUT manufacturer. Voltage change shall occur at zero crossing.
3. The EUT was tested for each selected combination of test level and duration with a sequence of three dips /interruptions with intervals of 10 s minimum. Each representative mode of operation was tested.

5.8.2 Results

| Reduction of supply voltage of | Voltage in % (in V) | Duration in parts of period (in ms) | Opinion |
|--------------------------------|---------------------|-------------------------------------|---------|
| interruption | 0 % (0V) | 0,5 (10 ms) | A |
| 60 % | 40 % (92 V) | 10 (200 ms) | A |
| 30 % | 70 % (161 V) | 25 (500 ms) | A |

A: no loss of function.

6 Test Setup Photos

Harmonic & Flicker



Conducted Emission



Disturbance power



Radiated Emission



ESD



Electrical Fast Transients, Surge, Dips



Injected currents (RF continues conducted)

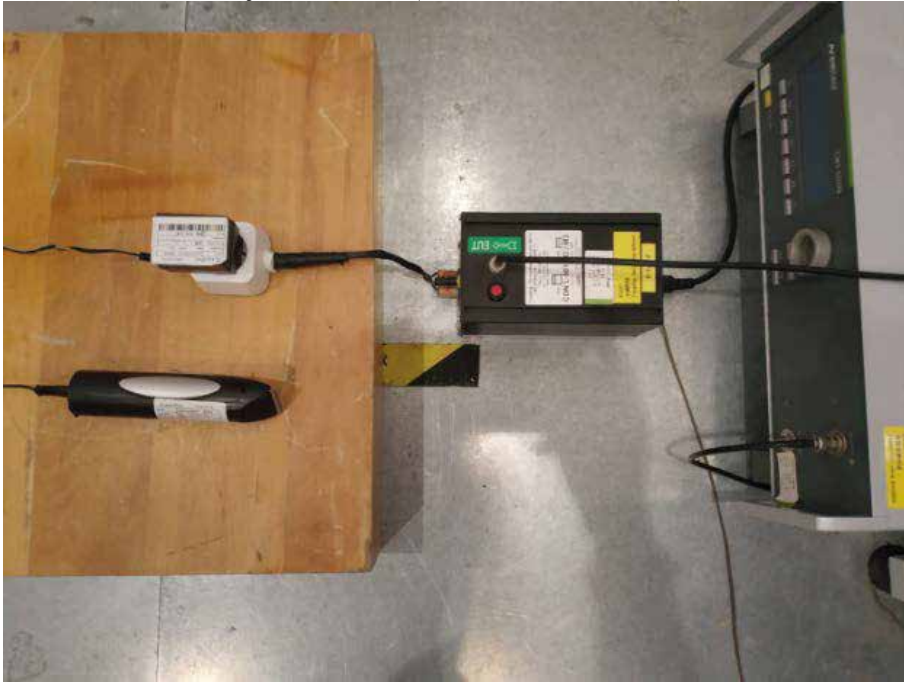

Radiated immunity



7 EUT Photos

Description: Overall view



Description: Top view



Description: Internal view 1



Description: Internal view 2



Description: PCB view 1



Description: PCB view 2

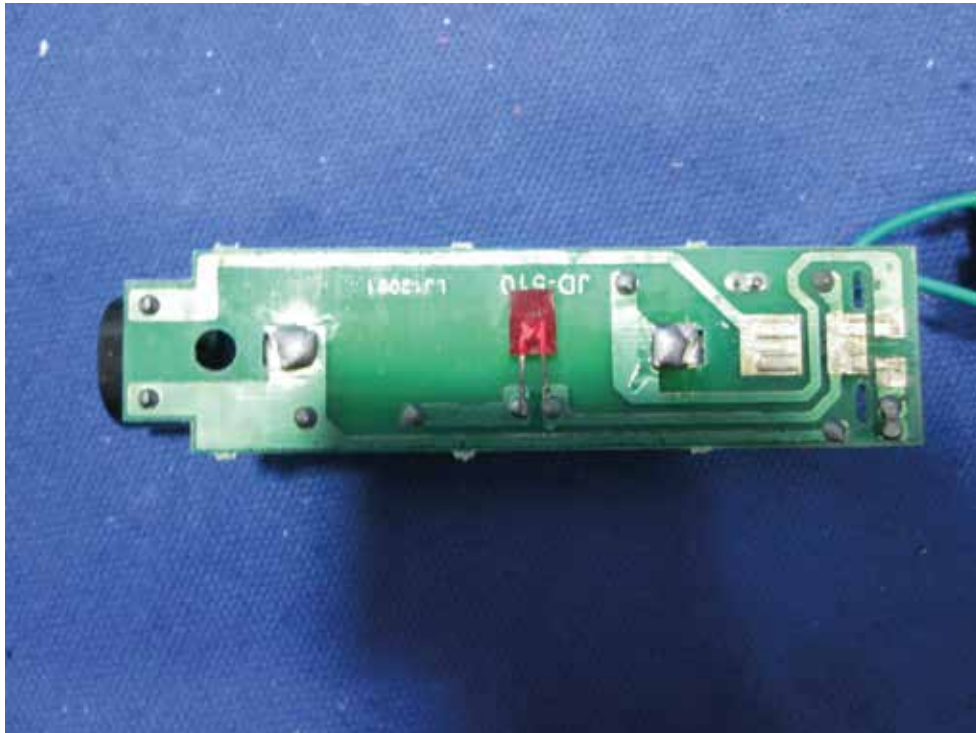

Description: Motor



Description: Adaptor



Test Report No.: EFSH15101363-IE-01-E01-A1

Eurofins Product Testing Service (Shanghai) Co., Ltd.
No.395 West Jiangchang Road, Jing'an District, Shanghai, 200436, P.R. China

8 Amendment 1

The test report ref. No. EFSH15101363-IE-01-E01 dated 2015-11-25, was modified on 2018-06-19 to include the following changes and/or additions:

1. Update technical standard to “EN 55014-1:2017”.
2. Update technical standard to “EN 55014-2:2015”.

After review, Radiated immunity test on JD-510 was performed and recorded.

Test report ref. No. EFSH15101363-IE-01-E01 was replaced by test report ref. No. EFSH15101363-IE-01-E01-A1.