



中国认可
国际互认
检测
TESTING
CNAS L3110



TEST REPORT

Reference No...... : WTD17S1297855E
Applicant..... :
Address..... :
Manufacturer..... :
Address..... :
Product..... : Tower Fan
Model(s)..... : Refer to Section 4.3
Standards..... : EN 55014-1: 2006+A1:2009+A2:2011
 EN 55014-2: 2015
 EN 61000-3-2: 2014
 EN 61000-3-3: 2013
Date of Receive sample.... : 2017-12-12
Date of Test..... : 2018-01-02 to 2018-01-29
Date of Issue..... : 2018-01-29
Test Result..... : **Pass**

Remarks:

The results shown in this test report refer only to the sample(s) tested, this test report cannot be reproduced, except in full, without prior written permission of the company. The report would be invalid without specific stamp of test institute and the signatures of compiler and approver.

Prepared By:

Waltek Services (Shenzhen) Co., Ltd.

Address: 1/F., Fukangtai Building, West Baima Road, Songgang Street, Baoan District, Shenzhen, Guangdong, China
 Tel :+86-755-83551033
 Fax:+86-755-83552400

Compiled by:

David Huang

David Huang / Project Engineer

Approved by:

Philo Zhong

Philo Zhong / Manager



1 Laboratories Introduction

Waltek Services (Shenzhen) Co., Ltd is a professional third-party testing and certification laboratory with multi-year product testing and certification experience, established strictly in accordance with ISO/IEC 17025 requirements, and accredited by ILAC (International Laboratory Accreditation Cooperation) member. A2LA (American Association for Laboratory Accreditation) of USA, Meanwhile, Waltek has got recognition as registration and accreditation laboratory from EMSD (Electrical and Mechanical Services Department), and American Energy star, FCC(The Federal Communications Commission), CEC(California energy efficiency), IC(Industry Canada). It's the strategic partner and data recognition laboratory of international authoritative organizations, such as Intertek(ETL-SEMKO), TÜV Rheinland, TÜV SÜD, etc.



Waltek Services (Shenzhen) Co., Ltd is one of the largest and the most comprehensive third party testing laboratory in China. Our test capability covered four large fields: safety test. ElectroMagnetic Compatibility(EMC), and energy performance, wireless radio. As a professional, comprehensive, justice international test organization, we still keep the scientific and rigorous work attitude to help each client satisfy the international standards and assist their product enter into globe market smoothly.



1.1 Test Facility

A. Accreditations for Conformity Assessment (International)

Country/Region	Accreditation Body	Scope	Note
USA	A2LA (Certificate No.: 4243.01)	FCC ID \ DOC \ VOC	1
Canada		IC ID \ VOC	2
Japan		MIC-T \ MIC-R	-
Europe		EMCD \ RED	-
Taiwan		NCC	-
Hong Kong		OFCA	-
Australia		RCM	-
India	International Services	WPC	-
Thailand		NTC	-
Singapore		IDA	-
Note:			
1. FCC Designation No.: CN1201. Test Firm Registration No.: 523476.			
2. IC Canada Registration No.: 7760A			

B.TCBs and Notify Bodies Recognized Testing Laboratory.

Recognized Testing Laboratory of	Notify body number
TUV Rheinland	Optional.
Intertek	
TUV SUD	
SGS	
Phoenix Testlab GmbH	0700
Element Materials Technology Warwick Ltd	0891
Timco Engineering, Inc.	1177
Eurofins Product Service GmbH	0681



2 Contents

	Page
COVER PAGE	1
1 LABORATORIES INTRODUCTION	2
1.1 TEST FACILITY	3
2 CONTENTS	4
3 REVISION HISTORY	5
4 GENERAL INFORMATION	6
4.1 GENERAL DESCRIPTION OF E.U.T	6
4.2 DETAILS OF E.U.T	6
4.3 MODEL LIST	6
4.4 SUBCONTRACTED	7
4.5 ABNORMALITIES FROM STANDARD CONDITIONS	7
5 TEST SUMMARY	8
6 EQUIPMENT USED DURING TEST	9
6.1 EQUIPMENT LIST	9
6.2 DESCRIPTION OF SUPPORT UNITS	10
6.3 MEASUREMENT UNCERTAINTY	10
6.4 TEST EQUIPMENT CALIBRATION	10
6.5 TEST MODE	11
7 EMISSION TEST RESULTS	13
7.1 CONDUCTED DISTURBANCE AT MAINS TERMINAL	13
7.2 DISTURBANCE POWER, 30MHZ TO 300MHZ	20
7.3 HARMONICS CURRENT EMISSION	24
7.4 VOLTAGE FLUCTUATION AND FLICKER	25
8 IMMUNITY TEST RESULTS	29
8.1 PERFORMANCE CRITERIA	29
8.2 ELECTROSTATIC DISCHARGE(ESD)	30
8.3 RADIO-FREQUENCY ELECTROMAGNETIC FIELDS, 80MHZ TO 1GHZ	32
8.4 ELECTRICAL FAST TRANSIENTS(EFT)	34
8.5 SURGE	36
8.6 INJECTED CURRENTS IMMUNITY, 0.15MHZ TO 80MHZ	37
8.7 VOLTAGE DIPS AND INTERRUPTIONS	39
9 PHOTOGRAPHS – TEST SETUP	40
9.1 PHOTOGRAPH – MAINS TERMINAL DISTURBANCE VOLTAGE TEST SETUP	40
9.2 PHOTOGRAPH – DISTURBANCE POWER TEST SETUP	41
9.3 PHOTOGRAPH – HARMONIC CURRENT AND VOLTAGE FLUCTUATION AND FLICKER TEST SETUP	43
9.4 PHOTOGRAPH – ESD IMMUNITY TEST SETUP	44
9.5 PHOTOGRAPH – RADIO-FREQUENCY ELECTROMAGNETIC FIELDS TEST SETUP	45
9.6 PHOTOGRAPH – EFT&SURGE&VOLTAGE DIPS AND INTERRUPTIONS IMMUNITY TEST SETUP	46
9.7 PHOTOGRAPH – INJECTED CURRENTS IMMUNITY TEST SETUP	47
10 PHOTOGRAPHS – CONSTRUCTIONAL DETAILS	49



3 Revision History

Test report No.	Date of Receipt sample	Date of Test	Date of Issue	Purpose	Comment	Approved
WTD17S1297855E	2017-12-12	2018-01-02 to 2018-01-29	2018-01-29	original	-	Valid



WALTEK



4 General Information

4.1 General Description of E.U.T.

Product..... : Tower Fan
 Model(s)..... : Refer to Section 4.3
 Model difference..... : Refer to Section 4.3
 Remark..... : Refer to Section 4.3

4.2 Details of E.U.T.

Ratings..... : Refer to Section 4.3

4.3 Model list

Product	Model(s)	Voltage Data	Power
Tower Fan	YF-TO2901,TF-29C1,YF-TO2902,TF-29C2, YF-TO2903,YF-TO2904,YF-TO2905, YF-TO2906,YF-TO2907,YF-TO2908,YF-TO2909, TF-29B, TF-29B1,TF-29R,YF-TO2910, YF-TO2911, YF-TO2912,YF-TO2913, YF-TO2914,YF-TO3201,YF-TO3202, YF-TO3203,YF-TO3204,YF-TO3205, YF-TO3206,YF-TO3207,YF-TO3208, YF-TO3209,YF-TO3210,YF-TO3211,YF-TO3212, YF-TO3212L,YF-TO3212D,YF-TO3213, YF-TO3214,YF-TO3614,YF-TO3601, YF-TO3602,YF-TO3603,YF-TO3605, YF-TO3606,YF-TO3607,YF-TO3610, YF-TO3611,YF-TO3612, YF-TO3612L,YF-TO3612D,YF-TO4605, YF-TO4607	AC 220-240V, 50/60Hz	45W
Model difference: Only the motor, model names and appearance are different.			
Remark: The models YF-TO2903, YF-TO3605, YF-TO3612L are the tested samples. Model YF-TO3605 and YF-TO3612L are tested all EMC items, Model YF-TO2903 has no electronic circuits, so only tested CE, DP and Flicker.			



4.4 Subcontracted

Whether parts of tests for the product have been subcontracted to other labs:

Yes No

If Yes, list the related test items and lab information:

Test Lab: N/A

Lab address: N/A

Test items: N/A

4.5 Abnormalities from Standard Conditions

None.



WALTEK



5 Test Summary

EMISSION		
Test Item	Test Standard	Result
Conducted Disturbance at Mains Terminal	EN 55014-1	Pass
Disturbance Power, 30MHz to 300MHz	EN 55014-1	Pass
Discontinuous Disturbance (Click)	EN 55014-1	N/A
Radiation Emission, 30MHz to 1000MHz	EN 55014-1	N/A
Harmonic Current emission	EN 61000-3-2	N/A
Voltage Fluctuation and Flicker	EN 61000-3-3	Pass
IMMUNITY		
Test Item	Test Method	Result
Electrostatic Discharge(ESD)	IEC 61000-4-2	Pass
Radiation Immunity (80MHz to 1GHz)	IEC 61000-4-3	Pass
Electrical Fast Transients (EFT)	IEC 61000-4-4	Pass
Surge	IEC 61000-4-5	Pass
Injected Currents, 0.15MHz to 80MHz	IEC 61000-4-6	Pass
Voltage Dips and Interruptions	IEC 61000-4-11	Pass

Remark:

Pass

Test item meets the requirement

Fail

Test item does not meet the requirement

N/A

Test case does not apply to the test object



6 Equipment Used during Test

6.1 Equipment List

Conducted Emissions at Mains Terminals Disturbance Voltage (Conducted Emission)(843 Shielding room)						
Item	Equipment	Manufacturer	Model No.	Serial No.	Last Calibration Date	Calibration Due Date
1	EMI Test Receiver	R&S	ESCI	100947	2017-09-12	2018-09-11
2	LISN	R&S	ENV216	100115	2017-09-12	2018-09-11
3	Cable	Top	TYPE16(3.5M)	-	2017-09-12	2018-09-11
Disturbance Power						
Item	Equipment	Manufacturer	Model No.	Serial No.	Last Calibration Date	Calibration Due Date
1	EMI Test Receiver	R&S	ESCI	100947	2017-09-12	2018-09-11
2	Absorbing Clamp	R&S	MDS21	100205	2017-10-15	2018-10-14
3	Cable	HUBER+SUHNER	CBL3	400NN0700 01	2017-10-15	2018-10-14
Harmonics and Flicker Measuring System						
Item	Equipment	Manufacturer	Model No.	Serial No.	Last Calibration Date	Calibration Due Date
1	Digital Power Analyzer	SCHAFFNER	CCN 1000-1	72625	2017-04-10	2018-04-09
2	Power Source	SCHAFFNER	NSG 1007	58477	2017-04-10	2018-04-09
Electrostatic Discharge						
Item	Equipment	Manufacturer	Model No.	Serial No.	Last Calibration Date	Calibration Due Date
1	Electrostatic Discharge Simulator	SCHLODER	SESD 216	606144	2017-11-14	2018-11-13
Radio-frequency electromagnetic fields						
Item	Equipment	Manufacturer	Model No.	Serial No.	Last Calibration Date	Calibration Due Date
1	Signal Generator	R&S	SMB100A	105942	2017-09-12	2018-09-11
2	RF Power Amplifier	BONN Elektronik	BLWA0830-160/100/40D	128740	2017-09-12	2018-09-11
3	Gestockte Breitband (S tacked) Log.-per.Antenna	SCHWARZBECK	STLP9128D	043	2017-09-12	2018-09-11
4	Power Meter	R&S	NRP2	102031	2017-09-12	2018-09-11
Surge, EFT, Voltage dips and Interruption						
Item	Equipment	Manufacturer	Model No.	Serial No.	Last Calibration Date	Calibration Due Date
1	All Modules Generator	SCHAFFNER	6150	34579	2017-09-22	2018-09-21



2	Capacitive Coupling Clamp	SCHAFFNER	CDN 8014	25311	2017-09-22	2018-09-21
3	Signal and Data Line Coupling Network	SCHAFFNER	CDN 117	25627	2017-09-22	2018-09-21
4	AC Power Supply	HENGYUAN	DTDGC-4	-	2017-09-22	2018-09-21
Conducted Immunity						
Item	Equipment	Manufacturer	Model No.	Serial No.	Last Calibration Date	Calibration Due Date
1	RF Generator	TESEQ	NSG4070	25781	2017-09-12	2018-09-11
2	CDN M-Type	TESEQ	CDN M016	25112	2017-09-12	2018-09-11
3	EM-Clamp	TESEQ	KEMZ 801	25453	2017-09-12	2018-09-11
4	Attenuator 6dB	TESEQ	ATN6050	25376	2017-09-12	2018-09-11

6.2 Description of Support Units

Equipment	Manufacturer	Model No.	Series No.
/	/	/	/

6.3 Measurement Uncertainty

Parameter	Uncertainty (Note 1)
Temperature	$\pm 1^{\circ}\text{C}$
Humidity	$\pm 5\%$
DC and low frequency voltages	$\pm 3\%$
Conducted Emission (150kHz-30MHz)	$\pm 3.64\text{dB}$
Disturbance Power (30MHz-300MHz)	$\pm 3.12\text{dB}$
Radiated Emission (30MHz-1000MHz)	$\pm 5.03\text{dB}$

Note 1: This uncertainty represents an expanded uncertainty expressed at approximately the 95% confidence level using a coverage factor of $k=2$.

6.4 Test Equipment Calibration

All the test equipments used are valid and calibrated by GUANG ZHOU GRG METROLOGY & TEST CO., LTD. address is No.163, Pingyun Rd. West of Huangpu Ave, Tianhe District, Guangzhou, Guangdong, China.



6.5 Test Mode

For Model:YF-TO3612L and YF-TO3605

Test Item	Test Mode	Test Voltage
EN 55014-1		
Conducted Disturbance at Mains Terminal, 150kHz to 30MHz	High speed + Normal wind + Swing*	AC 198V/50Hz AC 264V/50Hz*
	Middle speed + Normal wind + Swing	AC 198V/50Hz AC 264V/50Hz
	Low speed + Normal wind + Swing	AC 198V/50Hz AC 264V/50Hz
Disturbance Power, 30MHz to 300MHz	High speed + Normal wind + Swing*	AC 198V/50Hz AC 264V/50Hz*
	Middle speed + Normal wind + Swing	AC 198V/50Hz AC 264V/50Hz
	Low speed + Normal wind + Swing	AC 198V/50Hz AC 264V/50Hz
EN 61000-3-3		
Voltage fluctuation and Flicker	High speed + Normal wind + Swing*	AC 230V/50Hz
EN 55014-2		
Electrostatic Discharge(ESD) <input checked="" type="checkbox"/> Air Discharge: ±8kV <input checked="" type="checkbox"/> Contact Discharge: ±4kV <input checked="" type="checkbox"/> HCP & VCP: ±4kV	High speed + Normal wind + Swing*	AC 230V/50Hz
Radio-frequency electromagnetic fields (RS) 80MHz-1000MHz,3V/m,80%	High speed + Normal wind + Swing*	AC 230V/50Hz
Electrical Fast Transients (EFT) <input checked="" type="checkbox"/> 1KV AC(Input) <input type="checkbox"/> 0.5KV DC(Input) <input type="checkbox"/> 0.5KV signal line and Control	High speed + Normal wind + Swing*	AC 230V/50Hz
Surges <input checked="" type="checkbox"/> 1KV L-N <input type="checkbox"/> 2KV L-PE 5 positive at 90°, 5 negative at 270°.	High speed + Normal wind + Swing*	AC 230V/50Hz
Injected Currents, (CS) 0.15MHz to 80MHz <input checked="" type="checkbox"/> 3V AC(Input) <input type="checkbox"/> 1V DC(Input) <input type="checkbox"/> 1Vsignal,control (more than 3m)	High speed + Normal wind + Swing*	AC 230V/50Hz
Voltage Dips and Interruptions 0% <input checked="" type="checkbox"/> 0.5P/50Hz, <input checked="" type="checkbox"/> 0.5P/60Hz C 40% <input checked="" type="checkbox"/> 10P/50Hz, <input checked="" type="checkbox"/> 12P/60Hz C 70% <input checked="" type="checkbox"/> 25P/50Hz, <input checked="" type="checkbox"/> 30P/60Hz C	High speed + Normal wind + Swing*	AC 230V/50Hz
** shows the worst case mode which were recorded in this report.		



For Model: YF-TO2903

Test Item	Test Mode	Test Voltage
EN 55014-1		
Conducted Disturbance at Mains Terminal, 150kHz to 30MHz	High speed + Normal wind + Swing*	AC 198V/50Hz AC 264V/50Hz*
	Middle speed + Normal wind + Swing	AC 198V/50Hz AC 264V/50Hz
	Low speed + Normal wind + Swing	AC 198V/50Hz AC 264V/50Hz
Disturbance Power, 30MHz to 300MHz	High speed + Normal wind + Swing*	AC 198V/50Hz AC 264V/50Hz*
	Middle speed + Normal wind + Swing	AC 198V/50Hz AC 264V/50Hz
	Low speed + Normal wind + Swing	AC 198V/50Hz AC 264V/50Hz
EN 61000-3-3		
Voltage fluctuation and Flicker	High speed + Normal wind + Swing*	AC 230V/50Hz
** shows the worst case mode which were recorded in this report.		

WALTEK



7 Emission Test Results

7.1 Conducted Disturbance at Mains Terminal

Test Requirement	: EN 55014-1
Test Method	: EN 55014-1
Test Result	: Pass
Frequency Range	: 148.5kHz to 30MHz
Class/Severity	: Table 1 of EN 55014-1

7.1.1 E.U.T. Operation

Operating Environment:

Temperature	: 22.2°C
Humidity	: 53.3%RH
Atmospheric Pressure	: 101.2kPa
EUT Operation	: Refer to section 6.5.

7.1.2 Block Diagram of Test Setup

The Conducted Disturbance at Mains Terminal tests were performed in accordance with the EN 55014-1.

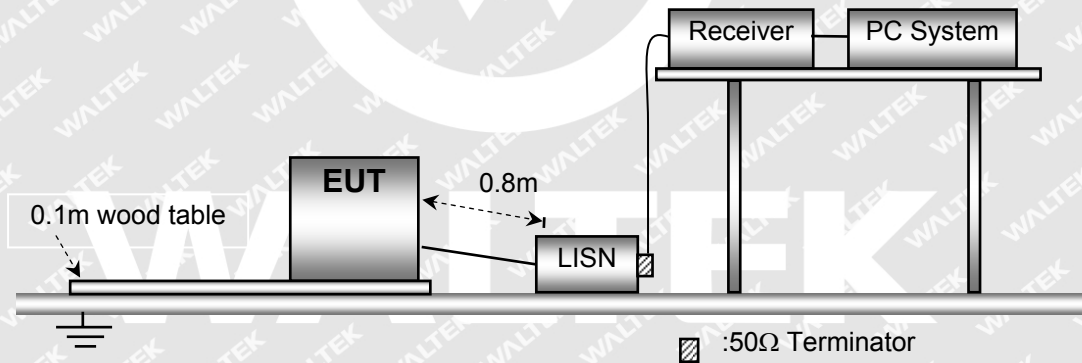

7.1.3 Measurement Data

The maximised peak emissions from the EUT was scanned and measured for both the Live and Neutral Lines. Quasi-peak & average measurements were performed if peak emissions were within 6dB of the average limit line.



7.1.4 Mains Terminals Disturbance Voltage Test Data

Model: YF-TO3612L

Live Line:

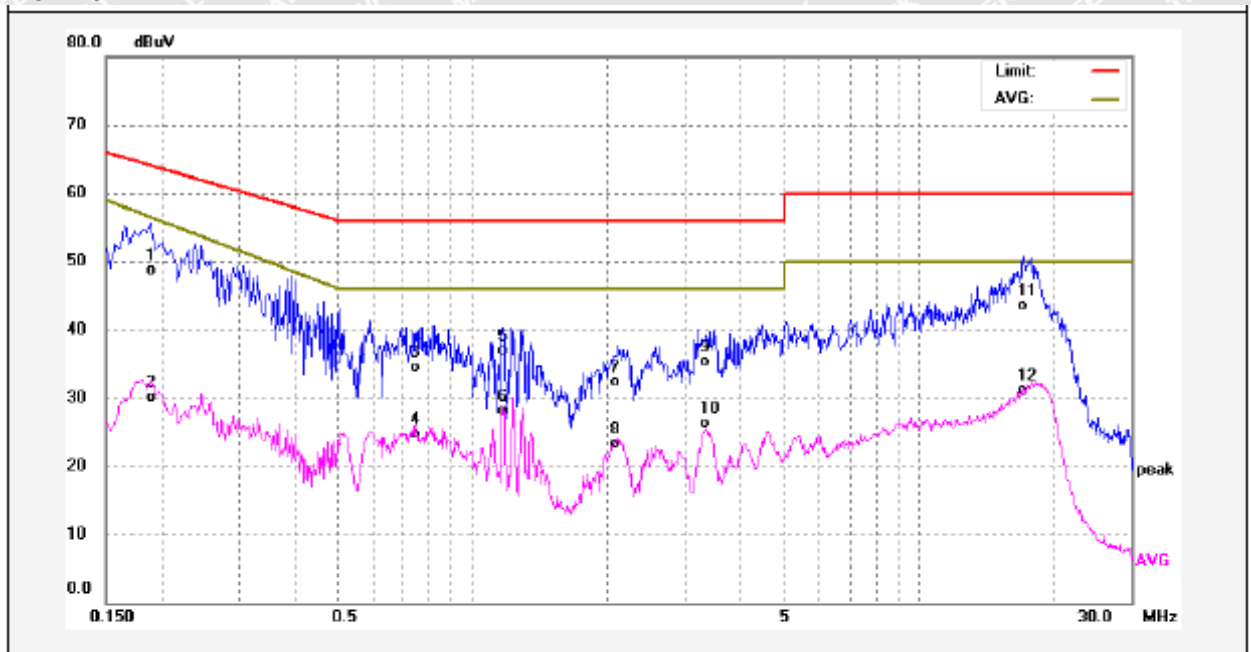

No.	Freq. (MHz)	Reading (dBuV)	Factor (dB)	Result (dBuV)	Limit dBuV	Margin (dB)	Detector	Remark
1	0.1900	39.04	9.63	48.67	64.03	-15.36	QP	
2	0.1900	20.40	9.63	30.03	56.44	-26.41	AVG	
3	0.7460	24.80	9.75	34.55	56.00	-21.45	QP	
4	0.7460	15.02	9.75	24.77	46.00	-21.23	AVG	
5	1.1700	26.95	9.86	36.81	56.00	-19.19	QP	
6	1.1700	18.24	9.86	28.10	46.00	-17.90	AVG	
7	2.1099	22.29	9.95	32.24	56.00	-23.76	QP	
8	2.1099	13.44	9.95	23.39	46.00	-22.61	AVG	
9	3.3220	25.47	9.93	35.40	56.00	-20.60	QP	
10	3.3220	16.32	9.93	26.25	46.00	-19.75	AVG	
11	17.1299	33.30	10.28	43.58	60.00	-16.42	QP	
12	17.1299	20.75	10.28	31.03	50.00	-18.97	AVG	



Neutral Line:

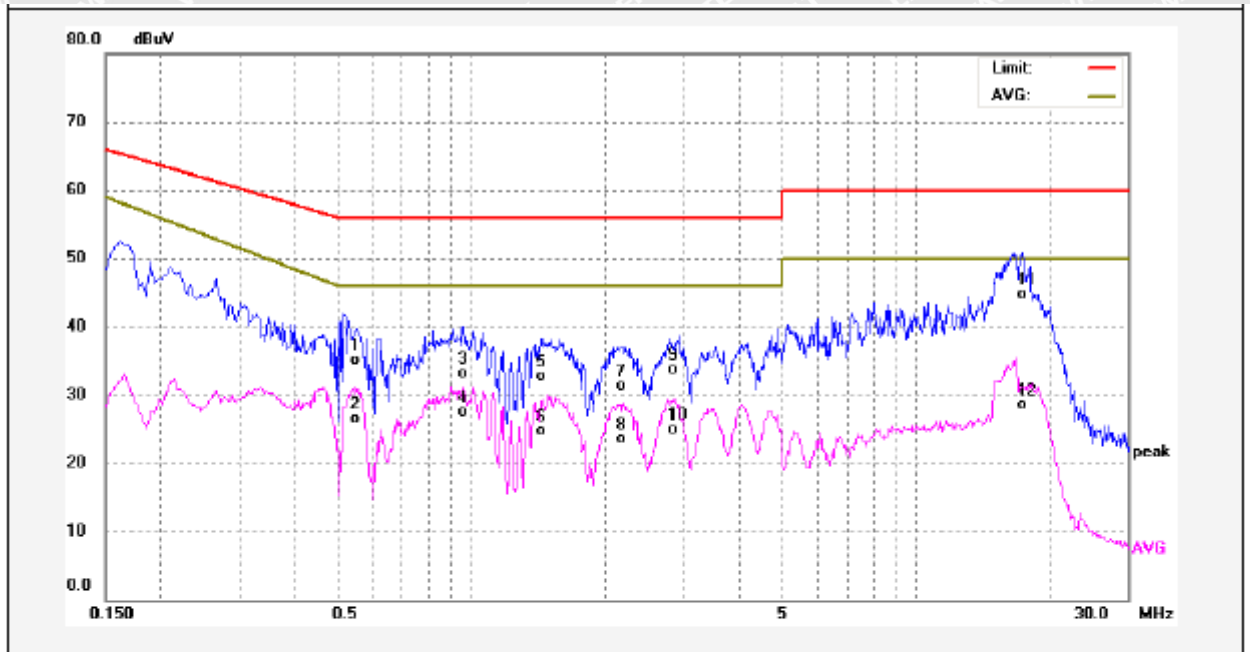

No.	Freq. (MHz)	Reading (dBuV)	Factor (dB)	Result (dBuV)	Limit dBuV	Margin (dB)	Detector	Remark
1	0.5540	25.45	9.69	35.14	56.00	-20.86	QP	
2	0.5540	16.76	9.69	26.45	46.00	-19.55	AVG	
3	0.9620	23.34	9.81	33.15	56.00	-22.85	QP	
4	0.9620	17.70	9.81	27.51	46.00	-18.49	AVG	
5	1.4540	22.74	9.90	32.64	56.00	-23.36	QP	
6	1.4540	14.82	9.90	24.72	46.00	-21.28	AVG	
7	2.1820	21.29	9.95	31.24	56.00	-24.76	QP	
8	2.1820	13.59	9.95	23.54	46.00	-22.46	AVG	
9	2.8100	23.86	9.93	33.79	56.00	-22.21	QP	
10	2.8100	15.04	9.93	24.97	46.00	-21.03	AVG	
11	17.3500	34.47	10.29	44.76	60.00	-15.24	QP	
12	17.3500	18.24	10.29	28.53	50.00	-21.47	AVG	



Model: YF-TO3605

Live Line:

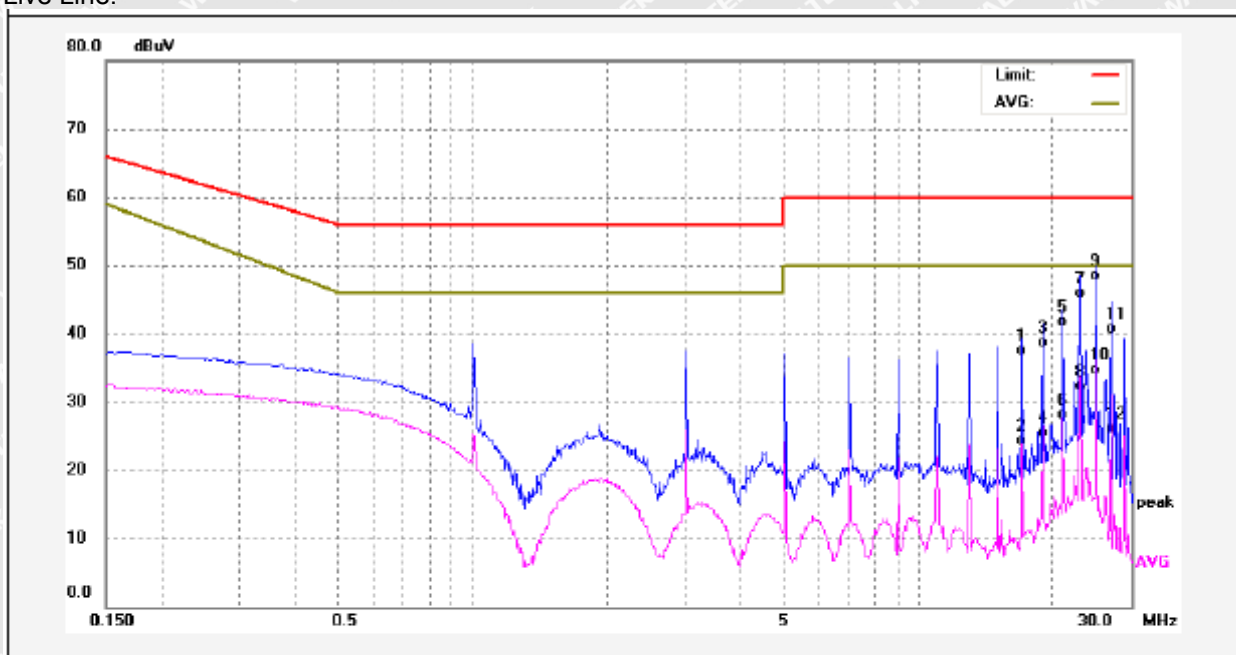

No.	Freq. (MHz)	Reading (dBuV)	Factor (dB)	Result (dBuV)	Limit dBuV	Margin (dB)	Detector	Remark
1	17.0300	27.16	10.28	37.44	60.00	-22.56	QP	
2	17.0300	13.94	10.28	24.22	50.00	-25.78	AVG	
3	19.0300	28.30	10.32	38.62	60.00	-21.38	QP	
4	19.0300	15.18	10.32	25.50	50.00	-24.50	AVG	
5	21.0340	31.43	10.35	41.78	60.00	-18.22	QP	
6	21.0340	17.83	10.35	28.18	50.00	-21.82	AVG	
7	23.0380	35.61	10.37	45.98	60.00	-14.02	QP	
8	23.0380	21.96	10.37	32.33	50.00	-17.67	AVG	
9	25.0419	38.16	10.39	48.55	60.00	-11.45	QP	
10	25.0419	24.40	10.39	34.79	50.00	-15.21	AVG	
11	27.0420	30.31	10.41	40.72	60.00	-19.28	QP	
12	27.0420	15.78	10.41	26.19	50.00	-23.81	AVG	



Neutral Line:

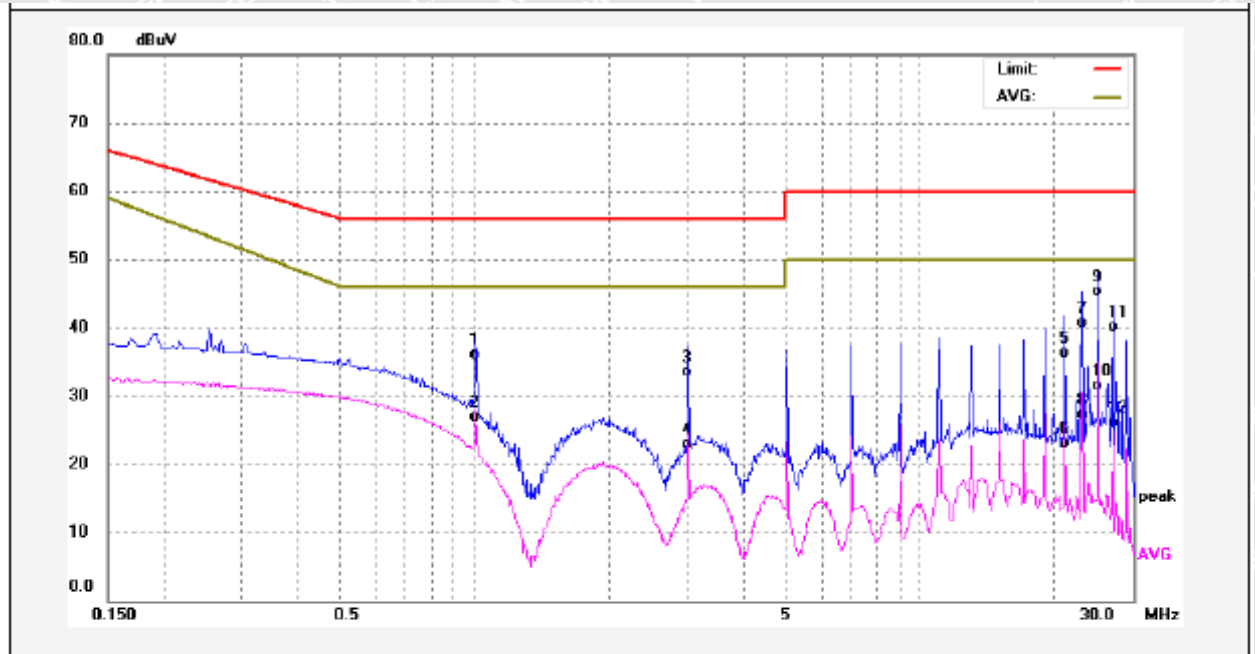

No.	Freq. (MHz)	Reading (dBuV)	Factor (dB)	Result (dBuV)	Limit dBuV	Margin (dB)	Detector	Remark
1	1.0020	26.31	9.83	36.14	56.00	-19.86	QP	
2	1.0020	17.04	9.83	26.87	46.00	-19.13	AVG	
3	3.0020	23.64	9.93	33.57	56.00	-22.43	QP	
4	3.0020	13.00	9.93	22.93	46.00	-23.07	AVG	
5	21.0300	25.99	10.35	36.34	60.00	-23.66	QP	
6	21.0300	12.73	10.35	23.08	50.00	-26.92	AVG	
7	23.0340	30.40	10.37	40.77	60.00	-19.23	QP	
8	23.0340	16.94	10.37	27.31	50.00	-22.69	AVG	
9	25.0380	34.86	10.39	45.25	60.00	-14.75	QP	
10	25.0380	21.20	10.39	31.59	50.00	-18.41	AVG	
11	27.0420	29.74	10.41	40.15	60.00	-19.85	QP	
12	27.0420	15.68	10.41	26.09	50.00	-23.91	AVG	



Model: YF-TO2903

Live Line:

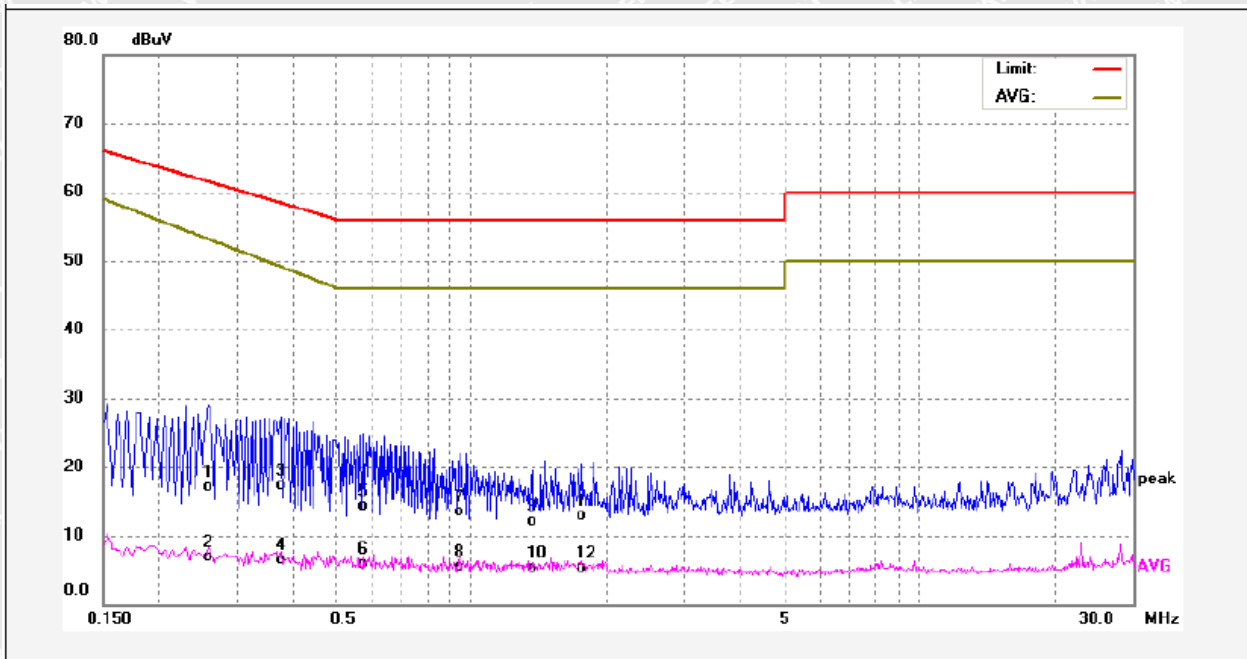

No.	Freq. (MHz)	Reading (dBuV)	Factor (dB)	Result (dBuV)	Limit dBuV	Margin (dB)	Detector	Remark
1	0.2580	7.49	9.64	17.13	61.49	-44.36	QP	
2	0.2580	-2.65	9.64	6.99	53.14	-46.15	AVG	
3	0.3740	7.63	9.63	17.26	58.41	-41.15	QP	
4	0.3740	-3.21	9.63	6.42	49.13	-42.71	AVG	
5	0.5740	4.61	9.70	14.31	56.00	-41.69	QP	
6	0.5740	-3.74	9.70	5.96	46.00	-40.04	AVG	
7	0.9420	3.79	9.81	13.60	56.00	-42.40	QP	
8	0.9420	-4.24	9.81	5.57	46.00	-40.43	AVG	
9	1.3660	2.15	9.89	12.04	56.00	-43.96	QP	
10	1.3660	-4.52	9.89	5.37	46.00	-40.63	AVG	
11	1.7660	2.93	9.93	12.86	56.00	-43.14	QP	
12	1.7660	-4.61	9.93	5.32	46.00	-40.68	AVG	



Neutral Line:

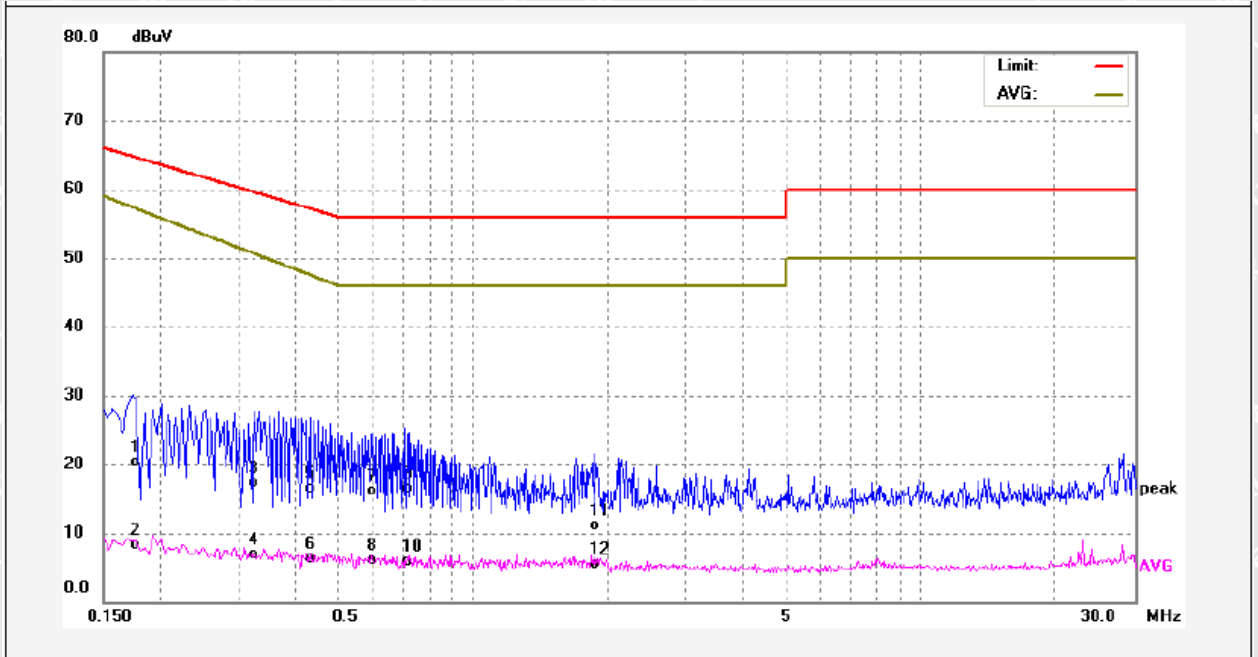

No.	Freq. (MHz)	Reading (dBuV)	Factor (dB)	Result (dBuV)	Limit dBuV	Margin (dB)	Detector	Remark
1	0.1768	10.69	9.64	20.33	64.63	-44.30	QP	
2	0.1768	-1.33	9.64	8.31	57.22	-48.91	AVG	
3	0.3260	7.67	9.63	17.30	59.55	-42.25	QP	
4	0.3260	-2.78	9.63	6.85	50.62	-43.77	AVG	
5	0.4340	6.77	9.64	16.41	57.18	-40.77	QP	
6	0.4340	-3.25	9.64	6.39	47.53	-41.14	AVG	
7	0.6020	6.46	9.72	16.18	56.00	-39.82	QP	
8	0.6020	-3.71	9.72	6.01	46.00	-39.99	AVG	
9	0.7100	6.70	9.73	16.43	56.00	-39.57	QP	
10	0.7100	-3.85	9.73	5.88	46.00	-40.12	AVG	
11	1.8740	1.17	9.94	11.11	56.00	-44.89	QP	
12	1.8740	-4.34	9.94	5.60	46.00	-40.40	AVG	



7.2 Disturbance Power, 30MHz to 300MHz

Test Requirement : EN 55014-1
 Test Method : EN 55014-1
 Test Result : Pass
 Frequency Range : 30MHz to 300MHz
 Class/Severity : Table 2a of EN 55014-1

7.2.1 E.U.T. Operation

Operating Environment:

Temperature : 23.1°C
 Humidity : 52.9%RH
 Barometric Pressure : 101.3kPa
 EUT Operation : Refer to section 6.5.

7.2.2 Block Diagram of Test Setup

The Disturbance Power test was performed in accordance with the EN 55014-1.

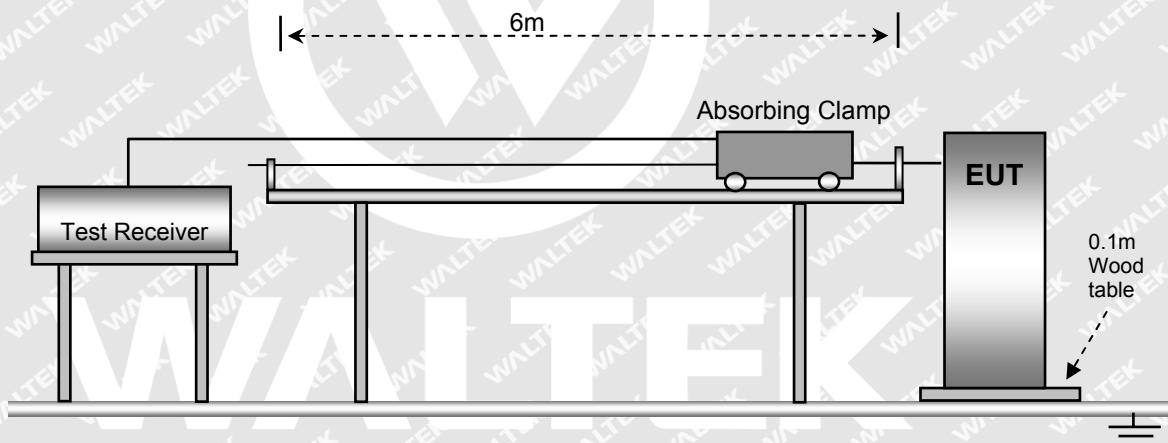

7.2.3 Measurement Data

Extending the cable to 6 meters, performed quasi-peak & average measurements since peak emissions from the EUT were detected within 15dB of the limit line. Average measurements were only performed if the quasi-peak measurements were within 15dB of the average limit line. According to the Clause 4.1.2.3, if both of the following conditions (1) and 2)) are fulfilled: 1) all emission readings from the equipment under test shall be lower than the applicable limits (Table 2a) reduced by the margin (Table 2b); 2) the maximum clock frequency shall be less than 30 MHz. The Appliances are deemed to comply in the frequency range from 300 MHz to 1 000 MHz



7.2.4 Disturbance Power Test Results

Model: YF-TO3612L

Line: AC Line

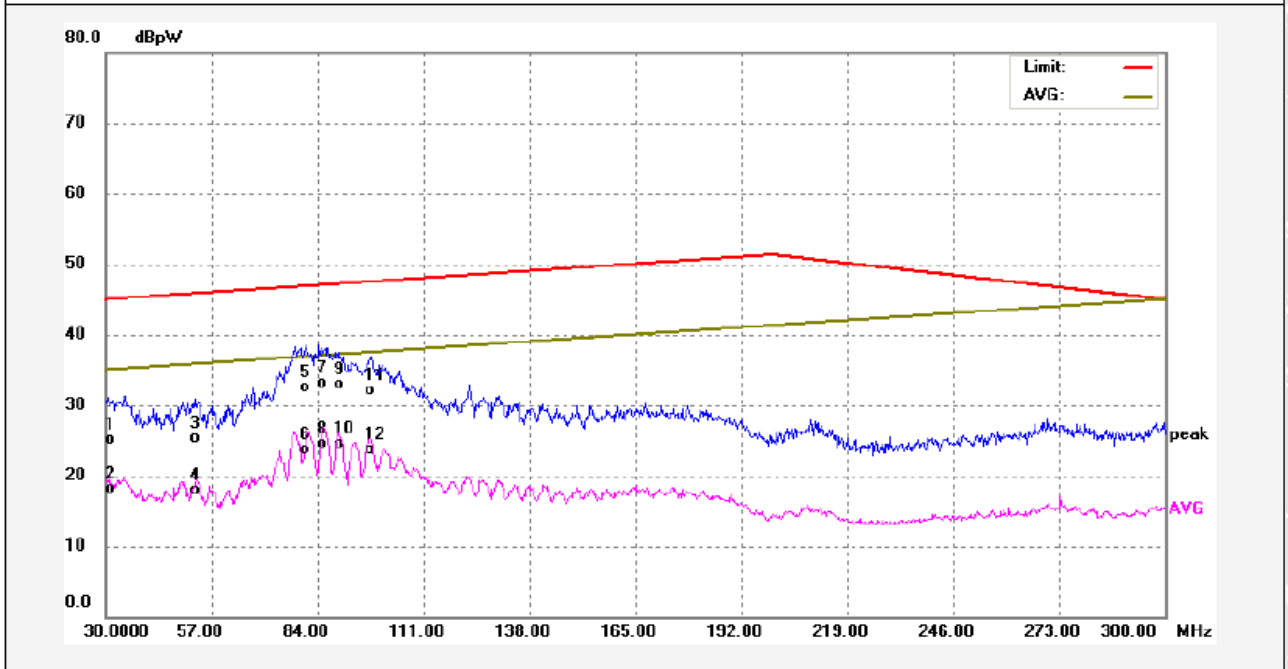

No.	Freq. (MHz)	Reading (dBpW)	Factor (dB)	Result (dBpW)	Limit (dBpW)	Margin (dB)	Detector	Remark
1	30.6000	16.07	8.99	25.06	45.02	-19.96	QP	
2	30.6000	9.07	8.99	18.06	35.02	-16.96	AVG	
3	52.9440	18.32	7.02	25.34	45.85	-20.51	QP	
4	52.9440	10.90	7.02	17.92	35.85	-17.93	AVG	
5	81.4640	24.51	8.07	32.58	46.91	-14.33	QP	
6	81.4640	15.73	8.07	23.80	36.91	-13.11	AVG	
7	85.8600	25.47	7.67	33.14	47.07	-13.93	QP	
8	85.8600	16.90	7.67	24.57	37.07	-12.50	AVG	
9	89.4440	25.62	7.35	32.97	47.20	-14.23	QP	
10	89.4440	17.13	7.35	24.48	37.20	-12.72	AVG	
11	97.5320	23.85	8.20	32.05	47.50	-15.45	QP	
12	97.5320	15.56	8.20	23.76	37.50	-13.74	AVG	



Model: YF-TO3605

Line: AC Line

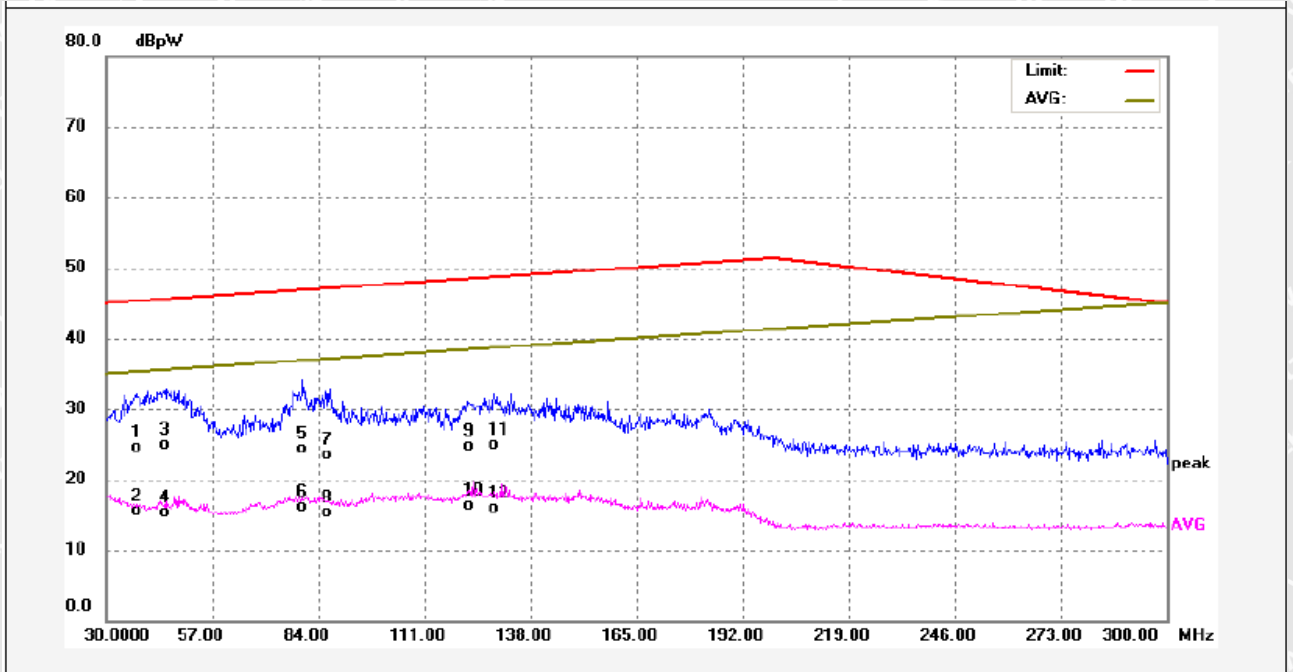

No.	Freq. (MHz)	Reading (dBpW)	Factor (dB)	Result (dBpW)	Limit (dBpW)	Margin (dB)	Detector	Remark
1	37.5839	16.64	7.79	24.43	45.28	-20.85	QP	
2	37.5839	7.68	7.79	15.47	35.28	-19.81	AVG	
3	45.6120	17.57	7.29	24.86	45.58	-20.72	QP	
4	45.6120	8.07	7.29	15.36	35.58	-20.22	AVG	
5	80.0560	16.15	8.19	24.34	46.85	-22.51	QP	
6	80.0560	7.94	8.19	16.13	36.85	-20.72	AVG	
7	86.9840	15.86	7.57	23.43	47.11	-23.68	QP	
8	86.9840	7.79	7.57	15.36	37.11	-21.75	AVG	
9	121.9160	16.20	8.41	24.61	48.41	-23.80	QP	
10	121.9160	7.85	8.41	16.26	38.41	-22.15	AVG	
11	128.8679	16.71	8.10	24.81	48.66	-23.85	QP	
12	128.8679	7.76	8.10	15.86	38.66	-22.80	AVG	



Model: YF-TO2903

Line: AC Line

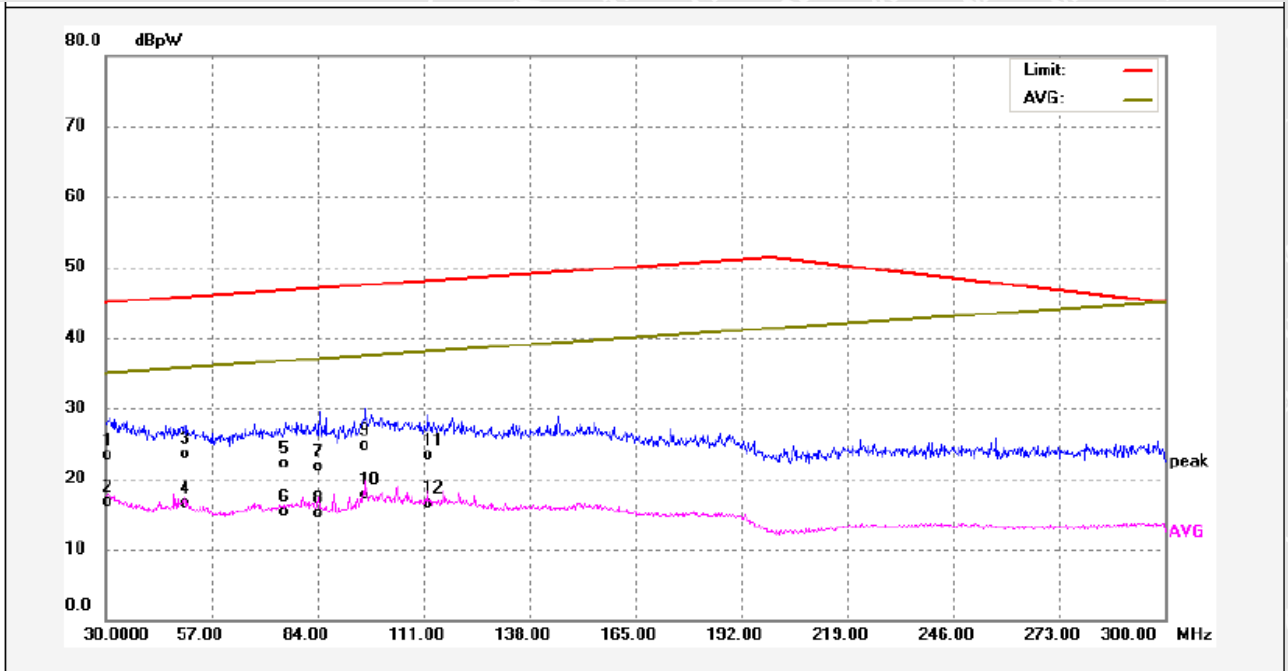

No.	Freq. (MHz)	Reading (dBpW)	Factor (dB)	Result (dBpW)	Limit (dBpW)	Margin (dB)	Detector	Remark
1	30.8560	14.34	8.95	23.29	45.03	-21.74	QP	
2	30.8560	7.68	8.95	16.63	35.03	-18.40	AVG	
3	50.4640	16.43	7.17	23.60	45.76	-22.16	QP	
4	50.4640	9.41	7.17	16.58	35.76	-19.18	AVG	
5	76.0320	14.16	7.92	22.08	46.71	-24.63	QP	
6	76.0320	7.47	7.92	15.39	36.71	-21.32	AVG	
7	84.6600	13.98	7.78	21.76	47.03	-25.27	QP	
8	84.6600	7.35	7.78	15.13	37.03	-21.90	AVG	
9	96.1679	16.57	8.04	24.61	47.45	-22.84	QP	
10	96.1679	9.66	8.04	17.70	37.45	-19.75	AVG	
11	112.1960	14.71	8.58	23.29	48.05	-24.76	QP	
12	112.1960	7.89	8.58	16.47	38.05	-21.58	AVG	



7.3 Harmonics Current Emission

Test Requirement : EN 61000-3-2
Test Method : EN 61000-4-7
Test Result : N/A
Class/Severity : Class A
Remark : This equipment uses symmetrical control method and the rated power is less than 75W. According to section 7 of EN 61000-3-2, tests need not be made on equipment.



WALTEK



7.4 Voltage Fluctuation and Flicker

Test Requirement..... : EN 61000-3-3
Test Method..... : EN 61000-4-15
Test Result : Pass

7.4.1 E.U.T. Operation

Operating Environment:

Temperature : 23.1°C
Humidity : 53.4%RH
Barometric Pressure : 101.4kPa
EUT Operation..... : Refer to section 6.5.

7.4.2 Block Diagram of Setup

The Voltage Fluctuation and Flicker test was performed in accordance with the EN 61000-4-15.

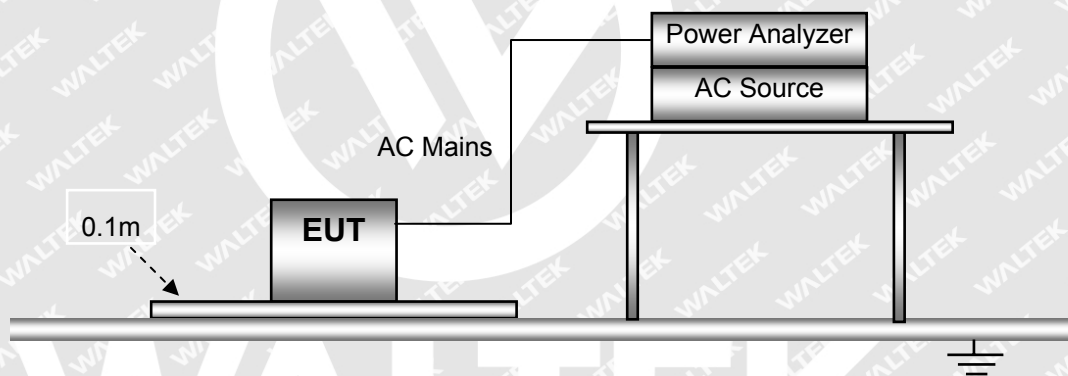



7.4.3 Voltage Fluctuation and Flicker Test Data

Flicker Test Summary per EN/IEC61000-3-3 Ed. 3.0 (2013) (Run time)

EUT: Tower fan

Test category: All parameters (European limits)

Test date: 2018/1/6

Test duration (min): 10

Comment: High speed + Normal wind + swing

Customer: YF-TO3612L

Tested by: WJ

Test Margin: 100

End time: 10:37:50

Start time: 10:27:23

Data file name: F-000152.cts_data

Test Result: Pass

Status: Test Completed

Pst_i and limit line

European Limits



Parameter values recorded during the test:

Vrms at the end of test (Volt): 229.72

Highest dt (%): 0.00

T-max (mS): 0

Highest dc (%): 0.00

Highest dmax (%): 0.00

Highest Pst (10 min. period): 0.064

Test limit (%): N/A

Test limit (mS): 500.0

Test limit (%): 3.30

Test limit (%): 4.00

Test limit: 1.000

N/A

Pass

Pass

Pass

Pass



Flicker Test Summary per EN/IEC61000-3-3 Ed. 3.0 (2013) (Run time)

EUT: Tower fan

Test category: All parameters (European limits)

Test date: 2018/1/6

Start time: 10:14:31

Test duration (min): 10

Data file name: F-000151.cts_data

Comment: High speed + Normal wind + swing

Customer: YF-TO3605

Tested by: WJ

Test Margin: 100

End time: 10:24:59

Test Result: Pass

Status: Test Completed

Pst_i and limit line

European Limits



Parameter values recorded during the test:

Vrms at the end of test (Volt): 229.84

Highest dt (%): 0.00

T-max (mS): 0

Highest dc (%): 0.00

Highest dmax (%): 0.00

Highest Pst (10 min. period): 0.064

Test limit (%): N/A

Test limit (mS): 500.0

Test limit (%): 3.30

Test limit (%): 4.00

Test limit: 1.000

N/A

Pass

Pass

Pass

Pass



Flicker Test Summary per EN/IEC61000-3-3 Ed. 3.0 (2013) (Run time)

EUT: Tower fan

Test category: All parameters (European limits)

Test date: 2018/1/6

Start time: 10:43:16

Tested by: WJ

Test Margin: 100

End time: 10:53:44

Test duration (min): 10

Data file name: F-000153.cts_data

Comment: High speed + Normal wind + swing

Customer: YF-TO2903

Test Result: Pass

Status: Test Completed

Pst_i and limit line

European Limits



Parameter values recorded during the test:

Vrms at the end of test (Volt): 229.79

Highest dt (%): 0.00

T-max (mS): 0

Highest dc (%): 0.00

Highest dmax (%): 0.00

Highest Pst (10 min. period): 0.064

Test limit (%): N/A

N/A

Test limit (mS): 500.0

Pass

Test limit (%): 3.30

Pass

Test limit (%): 4.00

Pass

Test limit: 1.000

Pass



8 Immunity Test Results

8.1 Performance Criteria

Performance criterion A: The apparatus shall continue to operate as intended during the test. No degradation of performance or loss of function is allowed below a performance level (or permissible loss of performance) specified by the manufacturer, when the apparatus is used as intended. If the minimum performance level or the permissible performance loss is not specified by the manufacturer, then either of these may be derived from the product description and documentation, and from what the user may reasonably expect from the apparatus if used as intended.

Performance criterion B: The apparatus shall continue to operate as intended after the test. No degradation of performance or loss of function is allowed below a performance level (or permissible loss of performance) specified by the manufacturer, when the apparatus is used as intended. During the test, degradation of performance is allowed, however, no change of actual operating state or stored data is allowed. If the minimum performance level or the permissible performance loss is not specified by the manufacturer, then either of these may be derived from the product description and documentation, and from what the user may reasonably expect from the apparatus if used as intended.

Performance criterion C: Temporary loss of function is allowed, provided the function is self-recoverable or can be restored by the operation of the controls, or by any operation specified in the instructions for use. For further details, please refer to EN 55014-2.



WALTEK



8.2 Electrostatic Discharge(ESD)

Test Requirement	:	EN 55014-2
Test Method	:	IEC 61000-4-2
Test Result	:	Pass
Discharge Impedance	:	330Ω / 150pF
Discharge Voltage	:	Air Discharge: ±8kV Contact Discharge: ±4kV HCP & VCP: ±4kV
Polarity	:	Positive & Negative
Number of Discharge	:	Minimum 10 times at each test point
Discharge Mode	:	Single Discharge
Discharge Period	:	1 second minimum

8.2.1 E.U.T. Operation

Operating Environment:

Temperature	:	22.7°C
Humidity	:	53.4%RH
Barometric Pressure	:	101.8kPa
EUT Operation	:	Refer to section 6.5.

8.2.2 Block Diagram of Setup

The ESD test was performed in accordance with the IEC 61000-4-2.

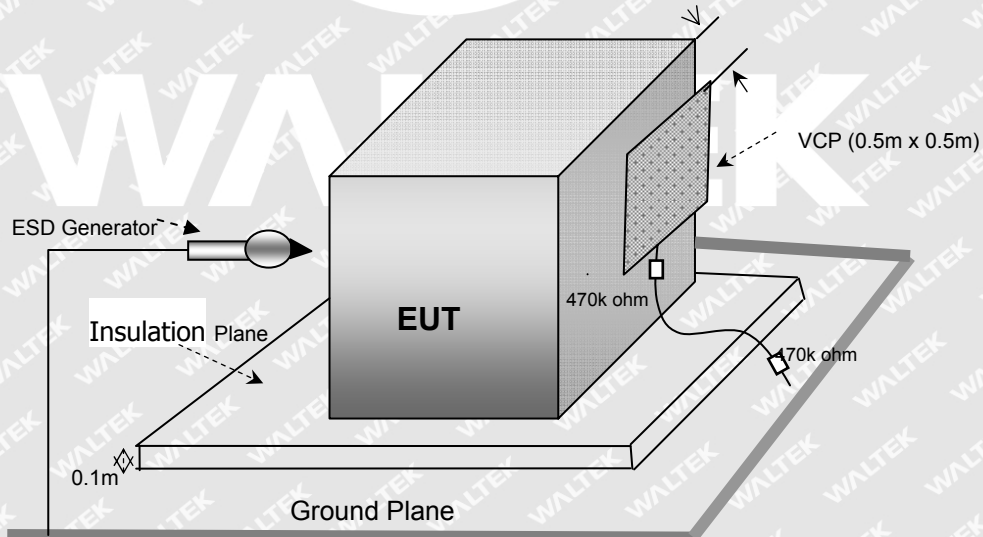



8.2.3 Direct Discharge Test Results

Observations: Test points: 1. All Exposed Surface & Seams;
2. All metallic part

Direct Discharge			Test Results	
Applied Voltage (kV)	Performance Criterion	Test Point	Contact Discharge	Air Discharge
±8	B	1	N/A	Pass
±4	B	2	Pass	N/A

8.2.4 Indirect Discharge Test Results

Observations: Test points: 1. All sides.

Indirect Discharge			Test Results	
Applied Voltage (kV)	Performance Criterion	Test Point	Horizontal Coupling	Vertical Coupling
±4	B	1	Pass	Pass



WALTEK



8.3 Radio-frequency electromagnetic fields, 80MHz to 1GHz

Test Requirement	: EN 55014-2
Test Method	: IEC 61000-4-3
Test Result	: Pass
Frequency Range	: 80MHz to 1GHz
Modulation	: 80%, 1kHz Amplitude Modulation.
Face of EUT	: Front, Back, Left, Right
Antenna polarisation	: Horizontal&Vertical

8.3.1 E.U.T. Operation

Operating Environment:

Temperature	: 22.4°C
Humidity	: 51%RH
Barometric Pressure	: 102.7kPa
EUT Operation	: Refer to section 6.5.

8.3.2 Block Diagram of Setup

The Radio-frequency electromagnetic fields Immunity test was performed in accordance with the IEC 61000-4-3.

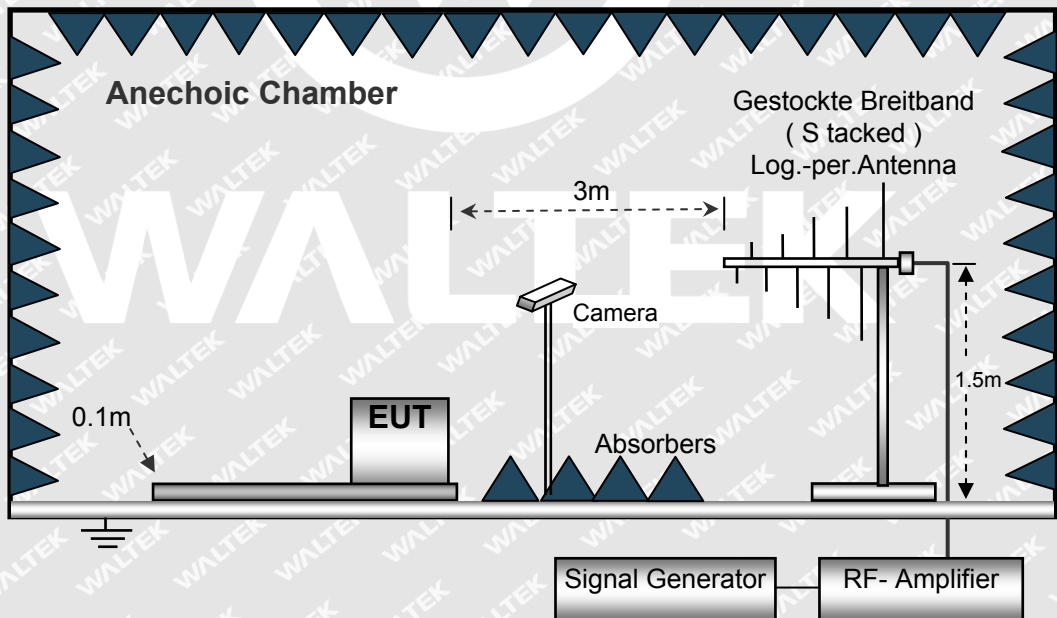



8.3.3 Test Results

Frequency	Face of EUT	Antenna polarisation	Test Level	Step Size	Dwell Time	Performance Criterion	Result
80 to 1000MHz	Front, Back, Left, Right	Horizontal	3V/m	1%	1s	A	Pass
80 to 1000MHz	Front, Back, Left, Right	Vertical	3V/m	1%	1s	A	Pass



WALTEK



8.4 Electrical Fast Transients(EFT)

Test Requirement	: EN 55014-2
Test Method	: IEC 61000-4-4
Test Result	: Pass
Polarity	: Positive & Negative
Repetition Frequency	: 5kHz
Burst Duration	: 300ms
Test Duration	: 2 minutes per level & polarity

8.4.1 E.U.T. Operation

Operating Environment:

Temperature	: 23.2°C
Humidity	: 53.5%RH
Barometric Pressure	: 101.9kPa
EUT Operation	: Refer to section 6.5.

8.4.2 Block Diagram of Setup

The Electrical Fast Transients Immunity test was performed in accordance with the IEC 61000-4-4.

For AC Mains or DC Ports:

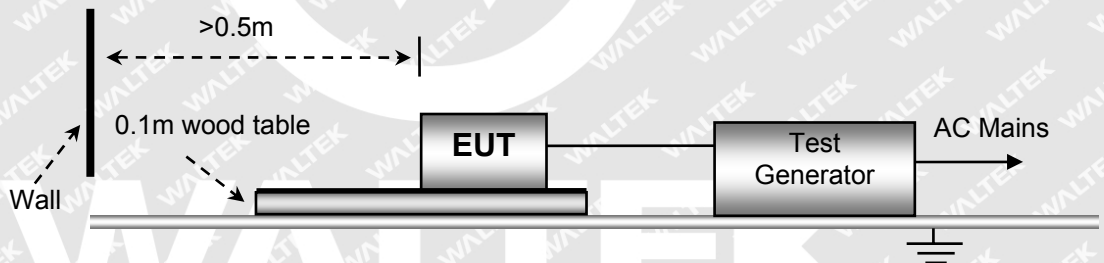

For Signal Ports:

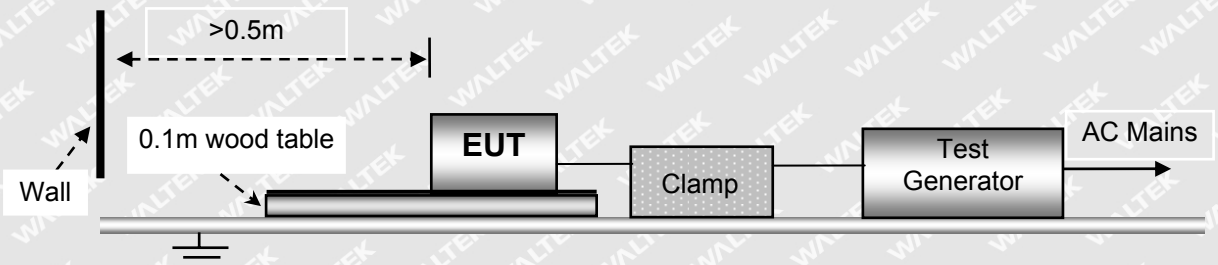



8.4.3 Test Results

Test Port	Test Level(kV)	Performance Criterion	Result
AC Mains	±1.0	B	PASS
Signal	±0.5	B	N/A ^a
DC Ports	±0.5	B	N/A

Remark:

- a Applicable only to cables which according to the manufacturer's specification supports communication on cable lengths greater than 3 m.



WALTEK



8.5 Surge

Test Requirement	: EN 55014-2
Test Method	: IEC 61000-4-5
Test Result	: Pass
Interval	: 60s between each surge
No. of surges	: 5 positive at 90°, 5 negative at 270°.

8.5.1 E.U.T. Operation

Operating Environment:

Temperature	: 23.3°C
Humidity	: 52.8%RH
Barometric Pressure	: 101.6kPa
EUT Operation	: Refer to section 6.5.

8.5.2 Block Diagram of Setup

The Surge Immunity test was performed in accordance with the IEC 61000-4-5.

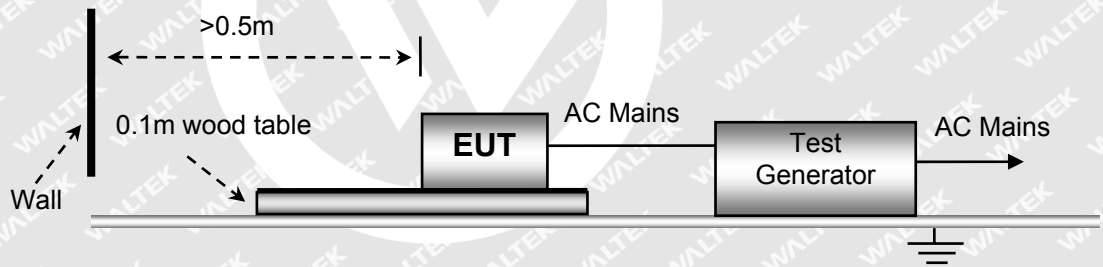

8.5.3 Test Results

Test Port	Applied Voltage (kV)	Performance criterion	Result
Between Live And Neutral:	±1	B	Pass
Between Live And Earth:	±2	B	N/A
Between Neutral And Earth:	±2	B	N/A



8.6 Injected Currents Immunity, 0.15MHz to 80MHz

Test Requirement	: EN 55014-2
Test Method	: IEC 61000-4-6
Test Result	: Pass
Frequency Range	: 0.15MHz to 80MHz
Modulation	: 80%, 1kHz Amplitude Modulation.

8.6.1 E.U.T. Operation

Operating Environment:

Temperature	: 22.1°C
Humidity	: 52.7% RH
Barometric Pressure	: 101.4kPa
EUT Operation	: Refer to section 6.5.

8.6.2 Block Diagram of Setup

The Injected Currents Immunity test was performed in accordance with the IEC 61000-4-6.

For AC Mains or DC Input:

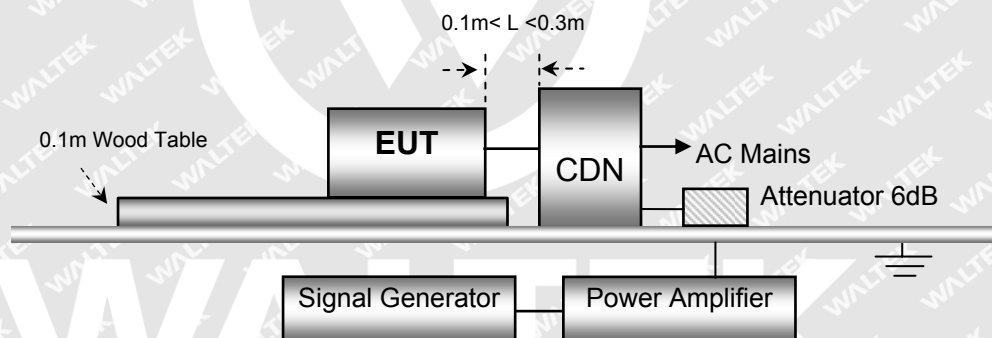

For Signal Ports:

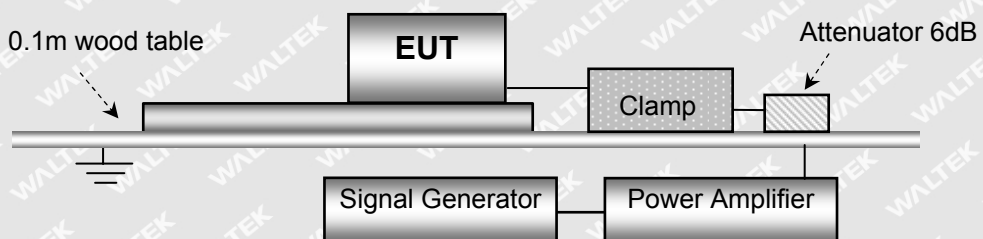



8.6.3 Test Results

Frequency	Line	Test Level	Modulation	Step Size	Dwell Time	Performance Criterion	Result
0.15MHz to 80MHz	AC Supply Cables	3Vr.m.s.	80%, 1kHz Amp. Mod.	1%	1s	A	PASS
0.15MHz to 80MHz	Signal	1Vr.m.s.	80%, 1kHz Amp. Mod.	1%	1s	A	N/A ^a
0.15MHz to 80MHz	DC in	1Vr.m.s.	80%, 1kHz Amp. Mod.	1%	1s	A	N/A ^b

Remark:

- a Applicable only to cables which according to the manufacturer's specification supports communication on cable lengths greater than 3 m.
- b Not apply Batter power input ports.



WALTEK



8.7 Voltage Dips and Interruptions

Test Requirement	:	EN 55014-2
Test Method	:	IEC 61000-4-11
Test Result	:	Pass
Test Level(Voltage reduction)	:	0% & 40% & 70 % of U_T (Supply Voltage)
No. of Dips / Interruptions	:	1 per Level at 20ms intervals

8.7.1 E.U.T. Operation

Operating Environment:

Temperature	:	22.1°C
Humidity	:	52.7% RH
Barometric Pressure	:	101.4kPa
EUT Operation	:	Refer to section 6.5.

8.7.2 Block Diagram of Setup

The Voltage Dips and Interruptions Immunity test was performed in accordance with the IEC 61000-4-11.

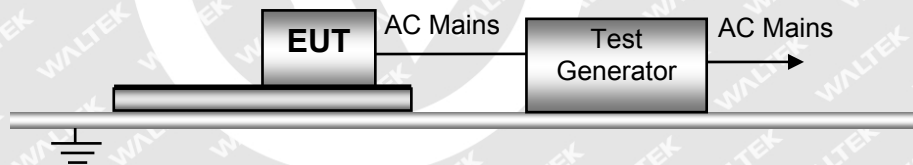

8.7.3 Test Results

Test Level in% U_T	Performance criterion	50Hz		60Hz	
		Duration	Result	Duration	Result
0	C	0.5	Pass	0.5	Pass
40	C	10	Pass	12	Pass
70	C	25	Pass	30	Pass



9 Photographs – Test Setup

9.1 Photograph – Mains Terminal Disturbance Voltage Test Setup

Model: YF-TO3612L

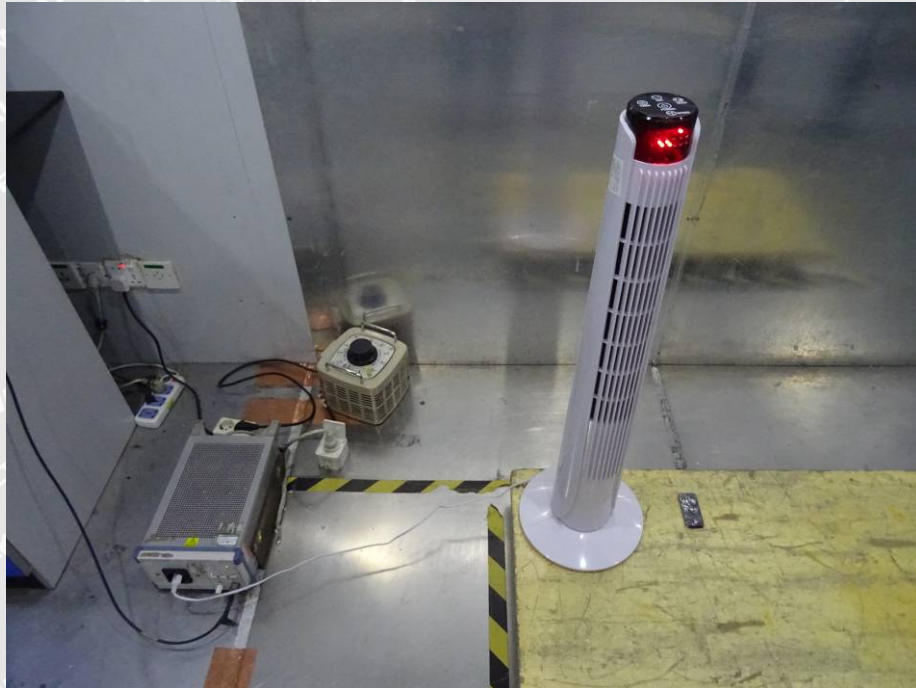

Model: YF-TO3605

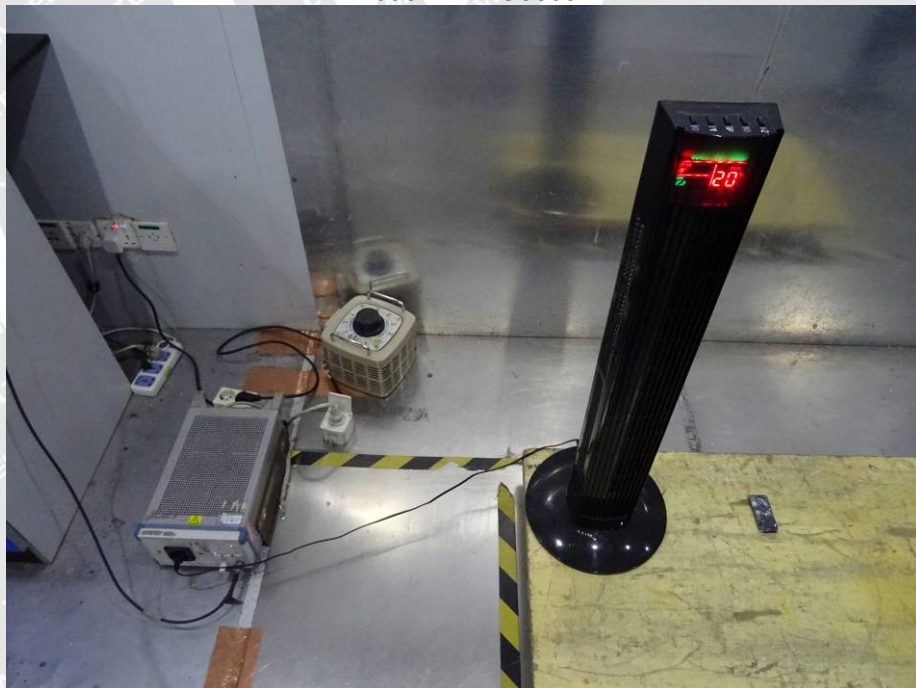



Model: YF-TO2903



9.2 Photograph – Disturbance Power Test Setup

Model: YF-TO3612L





Model: YF-TO3605



Model: YF-TO2903





9.3 Photograph – Harmonic Current and Voltage Fluctuation and Flicker Test Setup

Model: YF-TO3612L



Model: YF-TO3605





Model: YF-TO2903



9.4 Photograph – ESD Immunity Test Setup

Model: YF-TO3612L

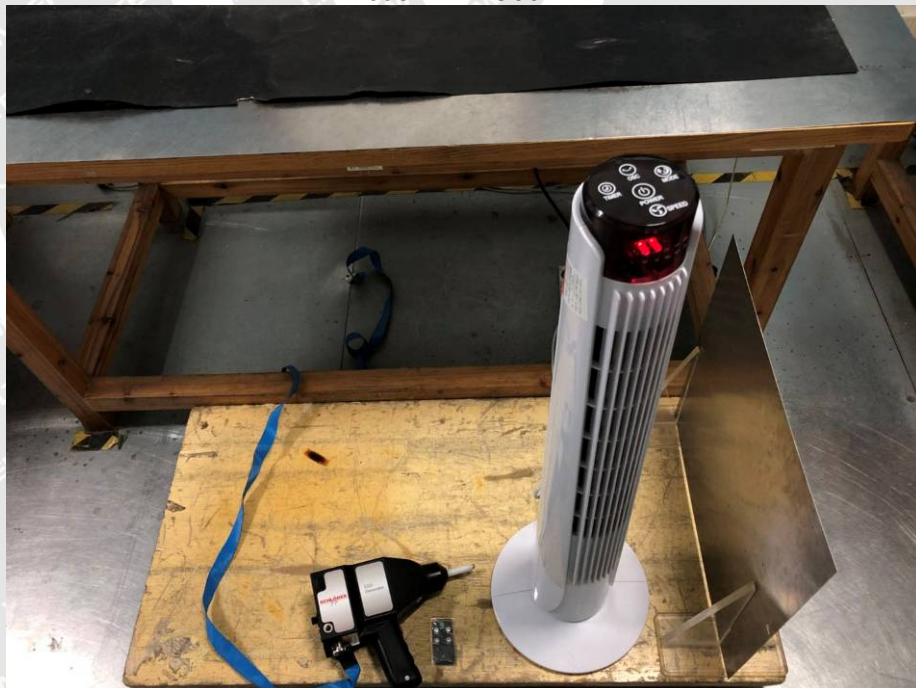



Model: YF-TO3605



9.5 Photograph –Radio-frequency electromagnetic fields Test Setup

Model: YF-TO3612L

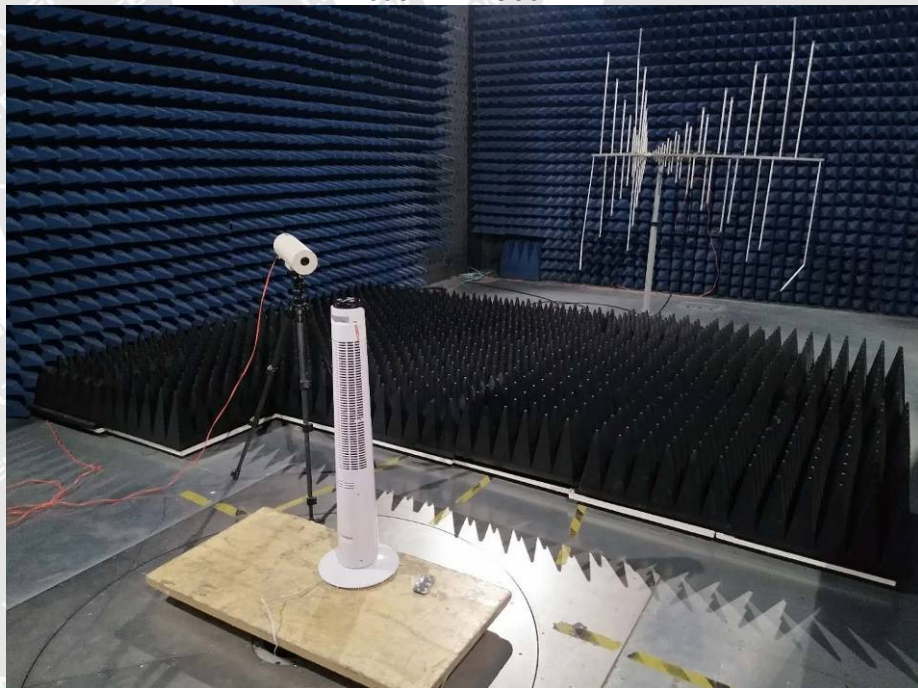



Model: YF-TO3605

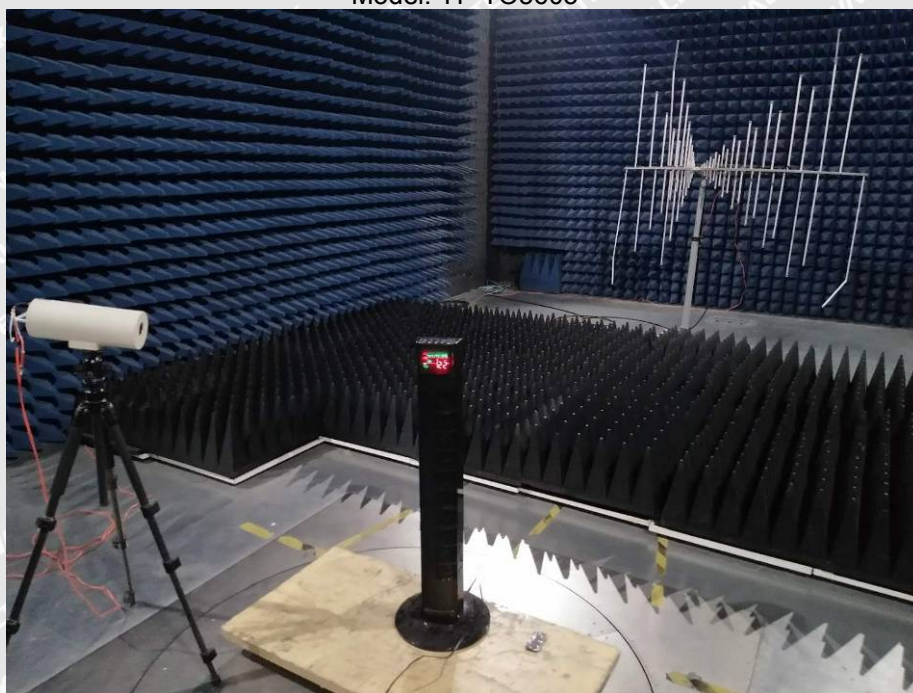

9.6 Photograph – EFT&Surge&Voltage Dips and Interruptions Immunity Test Setup

Model: YF-TO3612L





Model: YF-TO3605



9.7 Photograph – Injected Currents Immunity Test Setup

Model: YF-TO3612L





Model: YF-TO3605



WALTEK



10 Photographs – Constructional Details

Model: YF-TO3612L

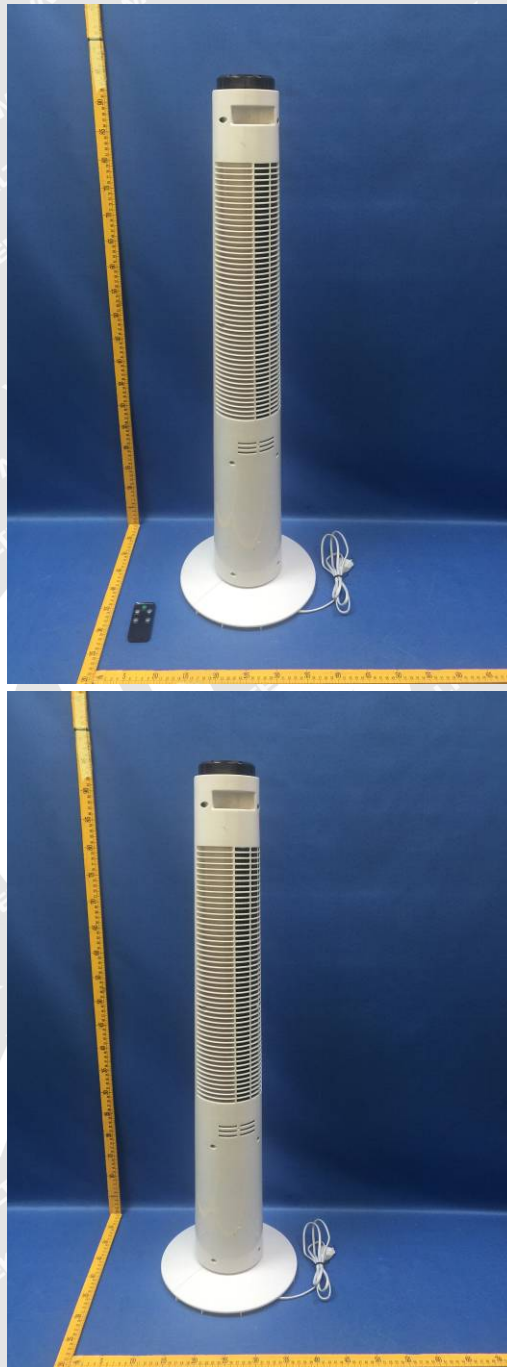





Model: YF-TO3605







Model: YF-TO2903







====End of Report====

WALTEK