





<b>TEST REPORT</b> <b>IEC 60335-2-29</b> <b>Safety of household and similar electrical appliances</b> <b>Part 2: Particular requirements for battery chargers</b>	
<b>Report Number</b> ..... :	150508146GZU-001
<b>Date of issue</b> ..... :	03 Jul., 2015 Modification 1: 15 Jun., 2016
<b>Total number of pages</b> .....	128
<b>Applicant's name</b> .....	YuYao LianYe Electronic Co., Ltd.
<b>Address</b> .....	NO.11 South Gongji Road, Linshan Town, Yuyao, Zhejiang, P. R. China
<b>Test specification:</b>	
<b>Standard</b> ..... :	EN 60335-2-29:2004 (Fourth Edition)+A2:2010 in conjunction with EN 60335-1:2012 +A11:2014 EN 62233:2008
<b>Test procedure</b> .....	
Non-standard test method .....	EK 1 557-13
<b>Test Report Form No.</b> .....	IEC60335_2_29I
<b>Test Report Form(s) Originator</b> .....	SIQ
<b>Master TRF</b> ..... :	Dated 2013-04
<b>Copyright © 2013 Worldwide System for Conformity Testing and Certification of Electrotechnical Equipment and Components (IECEE), Geneva, Switzerland. All rights reserved.</b>	
This publication may be reproduced in whole or in part for non-commercial purposes as long as the IECEE is acknowledged as copyright owner and source of the material. IECEE takes no responsibility for and will not assume liability for damages resulting from the reader's interpretation of the reproduced material due to its placement and context.	
If this Test Report Form is used by non-IECEE members, the IECEE/IEC logo and the reference to the CB Scheme procedure shall be removed.	
<b>This report is not valid as a CB Test Report unless signed by an approved CB Testing Laboratory and appended to a CB Test Certificate issued by an NCB in accordance with IECEE 02.</b>	

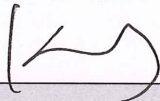

<b>Test item description</b> .....	power supply
<b>Trade Mark</b> .....	YuYao LianYe Electronic Co., Ltd.
<b>Manufacturer</b> .....	Same as applicant
<b>Model/Type reference</b> .....	LY045-XXX-YYYYZ (date code YYMM) (for details refer to General product information)
<b>Ratings</b> .....	Input: 100-240 V~, 50/60 Hz, 0,2 A, class II Output: 2,2-6,8 V  , 0050-1200 mA, 4,5 W max.

<b>Testing procedure and testing location:</b>		
<input checked="" type="checkbox"/>	<b>Testing Laboratory:</b>	Intertek Testing Services Shenzhen Ltd. Guangzhou Branch
<b>Testing location/ address .....</b>		Block E, No.7-2 Guang Dong Software Science Park, Caipin Road, Guangzhou Science City, GETDD, Guangzhou, China
<input type="checkbox"/>	<b>Associated CB Testing Laboratory:</b>	N/A
<b>Testing location/ address .....</b>		
<b>Tested by (name + signature).....:</b>		Kady Qin 
<b>Approved by (name + signature) .....</b>		King Xu 
<input type="checkbox"/>	<b>Testing procedure: TMP</b>	N/A
<b>Testing location/ address .....</b>		
<b>Tested by (name + signature).....:</b>		
<b>Approved by (name + signature) .....</b>		
<input type="checkbox"/>	<b>Testing procedure: WMT</b>	N/A
<b>Testing location/ address .....</b>		
<b>Tested by (name + signature).....:</b>		
<b>Witnessed by (name + signature) .....</b>		
<b>Approved by (name + signature) .....</b>		
<input type="checkbox"/>	<b>Testing procedure: SMT</b>	N/A
<b>Testing location/ address .....</b>		
<b>Tested by (name + signature).....:</b>		
<b>Approved by (name + signature) .....</b>		
<b>Supervised by (name + signature).....:</b>		

<b>List of Attachments (including a total number of pages in each attachment):</b>  <b>Please refer to the appendix in this report for details</b>	
<b>Summary of testing:</b>	
<b>Tests performed (name of test and test clause):</b> All applicable tests	<b>Testing location:</b> Intertek Testing Services Shenzhen Ltd. Guangzhou Branch Block E, No.7-2 Guang Dong Software Science Park, Caipin Road, Guangzhou Science City, GETDD, Guangzhou, China
<b>Summary of compliance with National Differences</b> Group and National differences of all CENELEC members have been considered.  <input checked="" type="checkbox"/> The product fulfils the requirements of : EN 60335-2-29:2004+A2:2010 to be used in conjunction with EN 60335-1:2012 +A11:2014 and EN 62233:2008	

Copy of marking plate(Representative)

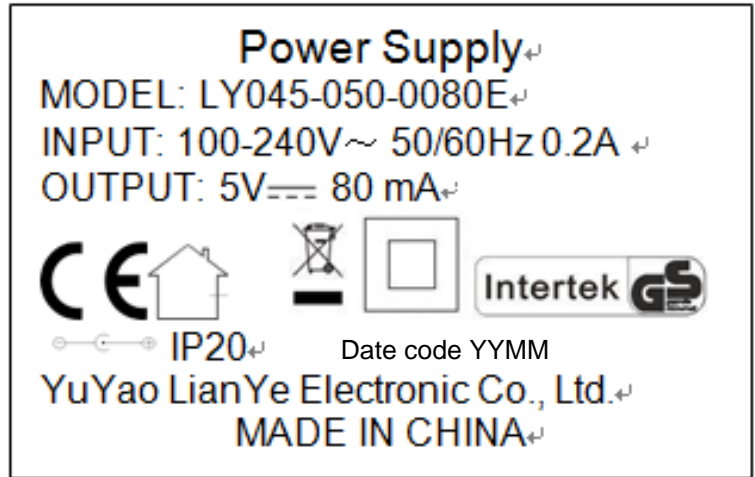

Note:

1. The above markings are the minimum requirements required by the safety standard. For the final production samples, the additional markings, which do not give rise to misunderstanding, may be added.
2. Other markings same as the marking plate above except the model name and rating.
3. Product information "date code YYMM" added.

<b>Test item particulars.....:</b>
<b>Classification of installation and use.....:</b> Class II, Portable and for household use
<b>Supply Connection .....</b> : Pluggable .....:
<b>Possible test case verdicts:</b> - test case does not apply to the test object.....: N/A - test object does meet the requirement.....: P (Pass) - test object does not meet the requirement.....: F (Fail)
<b>Testing.....:</b> <b>Date of receipt of test item .....</b> : 08 May., 2015 <b>Date (s) of performance of tests .....</b> : 08 May., 2015 – 03 Jul., 2015
<b>General remarks:</b>

**The test results presented in this report relate only to the object tested.**

**This report shall not be reproduced, except in full, without the written approval of the Issuing testing laboratory.**

**"(see Enclosure #)" refers to additional information appended to the report.**

**"(see appended table)" refers to a table appended to the report.**

**Throughout this report a  comma /  point is used as the decimal separator.**

**When determining the test conclusion, the Measurement Uncertainty of test has been considered. This report is for the exclusive use of Intertek's Client and is provided pursuant to the agreement between Intertek and its Client. Intertek's responsibility and liability are limited to the terms and conditions of the agreement. Intertek assumes no liability to any party, other than to the Client in accordance with the agreement, for any loss, expense or damage occasioned by the use of this report. Only the Client is authorized to permit copying or distribution of this report and then only in its entirety. Any use of the Intertek name or one of its marks for the sale or advertisement of the tested material, product or service must first be approved in writing by Intertek. The observations and test results in this report are relevant only to the sample tested. This report by itself does not imply that the material, product, or service is or has ever been under an Intertek certification program.**

**The test report only allows to be revised only within the report defined retention period unless standard or regulation was withdrawn or invalid.**

This report is based on and superseded original report No. GZ11051617-2 (dated 13 Sep., 2011), with below modification:

- Update the standard from "EN 60335-1:2002 + A1:2004 + A11:2004 + A12:2006 + A2:2006 + A13:2008+ A14:2010" to "EN 60335-1:2012 (Fifth Edition)"
- Add the requirement for A2:2010 of EN 60335-2-29:2004
- Update the critical component list (i: add alternative manufacturer for Y capacitor, PCB instead of "Various". ii: amend the model of Output wire form "1672, 1015, 1007" to "2464, 2468")
- Update user manual
- Add BS plug in this report.
- Add two photos of BS plug unit.

Tests of all applicable clauses were evaluation and repeated in this report.

This report is based on and superseded original report No. 131014014GZU-001 (dated 1 Nov., 2013), with below modification:

- Update the standard from "EN 60335-1:2012 (Fifth Edition)" to "EN 60335-1:2012 +A11:2014"
- Update the address of application from "8 West Ruhu Road, Yuyao, Zhejiang 315470, P. R. China." To "NO.11 South Gongji Road, Linshan Town, Yuyao, Zhejiang, P. R. China"
- Update the address of manufacture from "8 West Ruhu Road, Yuyao, Zhejiang 315470, P. R. China." To "NO.11 South Gongji Road, Linshan Town, Yuyao, Zhejiang, P. R. China"
- Update the address of factory from "8 West Ruhu Road, Yuyao, Zhejiang 315470, P. R. China." To "NO.11 South Gongji Road, Linshan Town, Yuyao, Zhejiang, P. R. China"
- Updated component list of table 20(A, added a manufacturer name to replace "--", added an alternative manufacture and deleted model 1672 for Primary leading wire; B, added an alternative manufacturer for PCB"; C, added a manufacturer name to replace "--", added two alternative manufactures for output wire)

- Updated the BS plug standard from BS1363: Part 3 + Amd 9543 + Amd 14225 + Amd 14540 + Amd 17437 to BS1363-3:1995 + A4:2012

As above modification, no test was reconsidered in this report.

**Modification1:**

**This report is based on and superseded original report No. 150508146GZU-001 (03 Jul., 2015), with below modification:**

- Add “date code YYYY” in Model name and Product information.
- Add date code YYYY on the marking plate.

**Per evaluating, no test is necessary.**

PAH test according to AfPS GS 2014:01 PAK is considered and passed, please refer to PAH test report 150508146GZU-PAH1 for details.  
EK1 557-13 is considered and passed

**Manufacturer’s Declaration per sub-clause 4.2.5 of IECEE 02:**

The application for obtaining a CB Test Certificate includes more than one factory location and a declaration from the Manufacturer stating that the sample(s) submitted for evaluation is (are) representative of the products from each factory has been provided..... :  
 **Yes**  
 **Not applicable**

**When differences exist; they shall be identified in the General product information section.**

**Name and address of factory (ies) .....** : YuYao LianYe Electronic Co., Ltd.  
NO.11 South Gongji Road, Linshan Town, Yuyao, Zhejiang, P. R. China

**General product information:**

The device is intended to charge Ni-MH battery pack (550 mAH max. capacitance). Other types of batteries may burst and causing injury to persons and damage.

For model description: LY045-XXX-YYYYZ (XXX=022-068; YYYY=0050-1200)(date code YYYY)  
 1, “XXX” can be 022-068 to indicate the rated output voltage, e.g. XXX=022 indicate 2,2 V;  
 2, “YYYY” can be 0050-1200 to indicate the rated output current, e.g. YYYY=0050 indicate 50 mA;  
 3, The “Z” denote type of integral plug, which can be replaced by “E” or “B”  
 “E” represents European plug comply with EN 50075 or;  
 “B” represents British-plug comply with BS 1363.

Those models had the same electrical and mechanical constructions, except for the different model name, output ratings.

The model: LY045-022-1200E, LY045-045-1000E and LY045-068-0600E were representative models for test, except for specified test items.

IEC 60335-2-29			
Clause	Requirement + Test	Result - Remark	Verdict
5	GENERAL CONDITIONS FOR THE TESTS		P
	Tests performed according to clause 5, e.g. nature of supply, sequence of testing, etc.		P
5.2	If the test of 21.101 is carried out two additional battery chargers required (IEC 60335-2-29)		P
5.101	Battery chargers tested as motor-operated appliances (IEC 60335-2-29)		P
6	CLASSIFICATION		
6.1	Protection against electric shock: Class 0, 0I, I, II, III .....	Class II	P
6.2	Protection against harmful ingress of water	IP X0	P
7	MARKING AND INSTRUCTIONS		P
7.1	Rated voltage or voltage range (V) .....	100-240V~	P
	Symbol for nature of supply, or .....	~	P
	Rated frequency (Hz) .....	50/60 Hz	P
	Rated power input (W), or .....		N/A
	Rated current (A) .....	0,2 A.	P
	Manufacturer's or responsible vendor's name, trademark or identification mark.....	YuYao LianYe Electronic Co., Ltd.	P
	Model or type reference .....	LY045-XXX-YYYYZ (for details refer to General product information)	P
	Symbol IEC 60417-5172, for class II appliances		P
	IP number, other than IPX0.....	IP 20	N/A
	Symbol IEC 60417-5180, for class III appliances, unless	Not this appliance	N/A
	the appliance is operated by batteries only		N/A
	Symbol IEC 60417-5036, for the enclosure of electrically-operated water valves in external hose-sets for connection of an appliance to the water mains, if the working voltage exceeds extra-low voltage	Not this appliance	N/A
	Battery chargers marked with (IEC 60335-2-29):		—
	- rated d.c. output voltage (V)	Within in range of 2,2-6,8 V	P

IEC 60335-2-29			
Clause	Requirement + Test	Result - Remark	Verdict
	- rated d.c. output current (A)	Within in range of 0050-1200 mA. (4,5 W max.)	P
	- rated current (A) of protective devices incorporated in a d.c. distribution board	No D.C distribution board	N/A
	- polarity of the output terminals indicated by symbol IEC 60417-5005 for the positive terminal and IEC 60417-5006 for the negative terminal (IEC 60335-2-29/A2)		P
	- time-current characteristic of fuse-links of the time-lag type	No such devices	N/A
	If the output exceeds 20 VA, battery chargers marked with (IEC 60335-2-29):		—
	- before charging, read the instructions		N/A
	- for indoor use or do not expose to rain, unless appliance is at least IPX4		N/A
	If the output exceeds 20 VA and the battery charger is for lead-acid batteries, battery chargers marked with (IEC 60335-2-29):		—
	- disconnect the supply before making or breaking the connections to the battery		N/A
	- WARNING: Explosive gases. Prevent flames and sparks. Provide adequate ventilation during charging.		N/A
	Battery chargers incorporating an engine cranking switch allowing the charger to supply a supplementary starting current for the engine marked with (IEC 60335-2-29):		—
	- maximum "on" time		N/A
	- minimum "off" time or maximum ratio between "on" time and "off" time		N/A
7.2	Warning for stationary appliances for multiple supply		N/A
	Warning placed in vicinity of terminal cover		N/A
7.3	Range of rated values marked with the lower and upper limits separated by a hyphen		N/A
	Different rated values marked with the values separated by an oblique stroke		N/A
7.4	Appliances adjustable for different rated voltages, the voltage setting is clearly discernible		N/A

IEC 60335-2-29			
Clause	Requirement + Test	Result - Remark	Verdict
	Requirement met if frequent changes are not required and the rated voltage to which the appliance is to be adjusted is determined from a wiring diagram		N/A
	Output voltage clearly discernible if the battery charger can be adjusted to different rated d.c. output voltages (IEC 60335-2-29)		N/A
7.5	Appliances with more than one rated voltage or one or more rated voltage ranges, marked with rated input or rated current for each rated voltage or range, unless		N/A
	the power input is related to the arithmetic mean value of the rated voltage range		N/A
	Relation between marking for upper and lower limits of rated power input or rated current and voltage is clear		N/A
7.6	Correct symbols used		P
	Symbol for nature of supply placed next to rated voltage	~	P
	Symbol for class II appliances placed unlikely to be confused with other marking		P
	Units of physical quantities and their symbols according to international standardized system		P
7.7	Connection diagram fixed to appliances to be connected to more than two supply conductors and appliances for multiple supply, unless		N/A
	correct mode of connection is obvious		N/A
7.8	Except for type Z attachment, terminals for connection to the supply mains indicated as follows:		N/A
	- marking of terminals exclusively for the neutral conductor (letter N)		N/A
	- marking of protective earthing terminals (symbol IEC 60417-5019)	Class II	N/A
	- marking not placed on removable parts		N/A
7.9	Marking or placing of switches which may cause a hazard	No switches	N/A
7.10	Indications of switches on stationary appliances and controls on all appliances by use of figures, letters or other visual means .....		N/A

IEC 60335-2-29			
Clause	Requirement + Test	Result - Remark	Verdict
	This applies also to switches which are part of a control		N/A
	If figures are used, the off position indicated by the figure 0		N/A
	The figure 0 indicates only OFF position, unless no confusion with the OFF position		N/A
7.11	Indication for direction of adjustment of controls		N/A
7.12	Instructions for safe use provided		P
	Details concerning precautions during user maintenance		P
	The instructions state that:		—
	- the appliance is not to be used by persons (including children) with reduced physical, sensory or mental capabilities, or lack of experience and knowledge, unless they have been given supervision or instruction		P
	- children being supervised not to play with the appliance		P
	Instructions for safe use contains (IEC 60335-2-29):		—
	- specification of types, number of cells and rated capacity of batteries that can be charged		P
	- warning against recharging non-rechargeable batteries		P
	- statement that during charging, batteries must be placed in the well-ventilated area, only for battery chargers for lead-acid batteries		N/A
	- statement that battery chargers must only be plugged into an earthed socket-outlet, only for portable Class I battery chargers for outdoor use		N/A
	- explanation of automatic function stating any limitation, only for automatic battery chargers		N/A
	Battery chargers for charging automobile batteries include substance concerning (IEC 60335-2-29):		—
	- The battery terminal not connected to the chassis has to be connected first. The other connection is to be made to the chassis, remote from the battery and fuel line. The battery charger is then to be connected to the supply mains;		N/A

IEC 60335-2-29			
Clause	Requirement + Test	Result - Remark	Verdict
	- After charging, disconnect the battery charger from the supply mains. Then remove the chassis connection and then the battery connection.		N/A
	For a part of class III construction supplied from a detachable power supply unit, the instructions state that the appliance is only to be used with the unit provided		N/A
	Instructions for class III appliances state that it must only be supplied at SELV, unless		N/A
	it is a battery-operated appliance, the battery being charged outside the appliance		N/A
7.12.1	Sufficient details for installation supplied	Not such equipment	N/A
	For an appliance intended to be permanently connected to the water mains and not connected by a hose-set, this is stated		N/A
	The instructions for battery chargers for installation in caravans and similar vehicles shall state that the connection to the supply mains is to be in accordance with the national wiring rules (IEC 60335-2-29).		N/A
7.12.2	Stationary appliances not fitted with means for disconnection from the supply mains having a contact separation in all poles that provide full disconnection under overvoltage category III, the instructions state that means for disconnection must be incorporated in the fixed wiring in accordance with the wiring rules		N/A
7.12.3	Insulation of the fixed wiring in contact with parts exceeding 50 K during clause 11; instructions state that the fixed wiring must be protected		N/A
7.12.4	Instructions for built-in appliances:		—
	- dimensions of space		N/A
	- dimensions and position of supporting and fixing		N/A
	- minimum distances between parts and surrounding structure		N/A
	- minimum dimensions of ventilating openings and arrangement		N/A
	- connection to supply mains and interconnection of separate components		N/A

IEC 60335-2-29			
Clause	Requirement + Test	Result - Remark	Verdict
	- allow disconnection of the appliance after installation, by accessible plug or a switch in the fixed wiring, unless		N/A
	a switch complying with 24.3		N/A
7.12.5	Replacement cord instructions, type X attachment with a specially prepared cord		N/A
	Replacement cord instructions, type Y attachment		N/A
	Replacement cord instructions, type Z attachment		P
7.12.6	Caution in the instructions for appliances incorporating a non-self-resetting thermal cut-out that is reset by disconnection of the supply mains, if this cut-out is required to comply with the standard		N/A
7.12.7	Instructions for fixed appliances stating how the appliance is to be fixed		N/A
7.12.8	Instructions for appliances connected to the water mains:		—
	- max. inlet water pressure (Pa) .....		N/A
	- min. inlet water pressure, if necessary (Pa) .....		N/A
	Instructions concerning new and old hose-sets for appliances connected to the water mains by detachable hose-sets		N/A
7.13	Instructions and other texts in an official language		P
7.14	Marking clearly legible and durable, rubbing test as specified		P
7.15	Markings on a main part		P
	Marking clearly discernible from the outside, if necessary after removal of a cover		P
	For portable appliances, cover can be removed or opened without a tool		N/A
	For stationary appliances, name, trademark or identification mark and model or type reference visible after installation		N/A
	For fixed appliances, name, trademark or identification mark and model or type reference visible after installation according to the instructions		N/A
	Indications for switches and controls placed on or near the components. Marking not on parts which can be positioned or repositioned in such a way that the marking is misleading		N/A

IEC 60335-2-29			
Clause	Requirement + Test	Result - Remark	Verdict
7.16	Marking of a possible replaceable thermal link or fuse link clearly visible with regard to replacing the link		N/A
7.101	D.C. distribution boards marked with (IEC 60335-2-29):		—
	- maximum output current (A) for each output circuit.....		N/A
	- types of any additional power supply which can be connected		N/A
<b>8</b>	<b>PROTECTION AGAINST ACCESS TO LIVE PARTS</b>		<b>P</b>
8.1	Adequate protection against accidental contact with live parts		P
8.1.1	Requirement applies for all positions, detachable parts removed		P
	Lamps behind a detachable cover not removed, if conditions met	No such parts	N/A
	Insertion or removal of lamps, protection against contact with live parts of the lamp cap	No such parts	N/A
	Use of test probe B of IEC 61032, with a force not exceeding 1 N: no contact with live parts		P
	Use of test probe B of IEC 61032 through openings, with a force of 20N: no contact with live parts		P
8.1.2	Use of test probe 13 of IEC 61032, with a force not exceeding 1 N, through openings in class 0 appliances and class II appliances/constructions: no contact with live parts		P
	Test probe 13 also applied through openings in earthed metal enclosures having a non-conductive coating: no contact with live parts		N/A
8.1.3	For appliances other than class II, use of test probe 41 of IEC 61032, with a force not exceeding 1 N: no contact with live parts of visible glowing heating elements		N/A
8.1.4	Accessible part not considered live if:		—
	- safety extra-low a.c. voltage: peak value not exceeding 42,4 V		N/A
	- safety extra-low d.c. voltage: not exceeding 42,4 V	The output voltage max.: 7,26 Vdc:	P

IEC 60335-2-29			
Clause	Requirement + Test	Result - Remark	Verdict
	- or separated from live parts by protective impedance	CY1, CY2; 2,2 nF	P
	If protective impedance: d.c. current not exceeding 2 mA, and		N/A
	a.c. peak value not exceeding 0,7 mA	0,276 mA <sub>peak</sub> (CY1:2,2 nF short-circuited)	P
	- for peak values over 42,4 V up to and including 450 V, capacitance not exceeding 0,1 μF	0,0011 μF	P
	- for peak values over 450 V up to and including 15 kV, discharge not exceeding 45 μC		N/A
	- for peak values over 15kV, the energy in the discharge not exceeding 350 mJ		N/A
8.1.5	Live parts protected at least by basic insulation before installation or assembly:		—
	- built-in appliances		N/A
	- fixed appliances		N/A
	- appliances delivered in separate units		N/A
8.2	Class II appliances and constructions constructed so that there is adequate protection against accidental contact with basic insulation and metal parts separated from live parts by basic insulation only		P
	Only possible to touch parts separated from live parts by double or reinforced insulation		P
9	STARTING OF MOTOR-OPERATED APPLIANCES		N/A
	Requirements and tests are specified in part 2 when necessary		N/A
10	POWER INPUT AND CURRENT		P
10.1	Power input at normal operating temperature, rated voltage and normal operation not deviating from rated power input by more than shown in table 1 .:	(see appended table)	P
	Test carried out at upper and lower limits of the ranges for appliances with one or more rated voltage ranges, unless		P
	the rated power input is related to the arithmetic mean value		N/A
10.2	Current at normal operating temperature, rated voltage and normal operation not deviating from rated current by more than shown in table 2.....:	(see appended table)	P

IEC 60335-2-29			
Clause	Requirement + Test	Result - Remark	Verdict
	Test carried out at upper and lower limits of the ranges for appliances with one or more rated voltage ranges, unless		N/A
	the rated current is related to the arithmetic mean value of the range		N/A
10.101	No-load d.c. output voltage does not exceed 42,2 V (IEC 60335-2-29).....:	7,48 Vdc max.	P
10.102	Arithmetic mean value of output current does not deviate from rated d.c. output current by more than 10 % (IEC 60335-2-29)	(see appended table)	P
11	HEATING		P
11.1	No excessive temperatures in normal use		P
11.2	The appliance is held, placed or fixed in position as described.....:		P
	Battery chargers are placed in the test corner as specified for heating appliances (IEC 60335-2-29)		P
11.3	Temperature rises, other than of windings, determined by thermocouples		P
	Temperature rises of windings determined by resistance method, unless		P
	the windings are non-uniform or it is difficult to make the necessary connections	Thermocouple method also performed	P
11.4	Heating appliances operated under normal operation at 1,15 times rated power input (W).....:		N/A
11.5	Battery chargers are only supplied at 1,06 times rated voltage (IEC 60335-2-29)	240 X 1,06 = 254,4 Vac 100 X 0,94 = 94 Vac	P
11.6	Combined appliances operated under normal operation at most unfavourable voltage between 0,94 and 1,06 times rated voltage (V).....:		N/A
11.7	Battery chargers are operated until steady conditions are established (IEC 60335-2-29)		P
11.8	Temperature rises monitored continuously and not exceeding the values in table 3.....:	(see appended table)	P
	If the temperature rise of a motor winding exceeds the value of table 3, or		N/A
	if there is doubt with regard to classification of insulation,		N/A
	tests of Annex C are carried out		N/A

IEC 60335-2-29			
Clause	Requirement + Test	Result - Remark	Verdict
	Sealing compound does not flow out		P
	Protective devices do not operate, except		P
	components in protective electronic circuits tested for the number of cycles specified in 24.1.4		N/A
<b>13</b>	<b>LEAKAGE CURRENT AND ELECTRIC STRENGTH AT OPERATING TEMPERATURE</b>		<b>P</b>
13.1	Leakage current not excessive and electric strength adequate		P
	Heating appliances operated at 1,15 times the rated power input (W).....:		N/A
	Motor-operated appliances and combined appliances supplied at 1,06 times the rated voltage (V).....:	240X1,06=254,4 Vac	P
	Protective impedance and radio interference filters disconnected before carrying out the tests		N/A
13.2	For class 0, class II and class III appliances, leakage current measured by means of the circuit described in figure 4 of IEC 60990		P
	For other appliances, a low impedance ammeter may be used		N/A
	Leakage current measurements .....	(see appended table)	P
13.3	The appliance is disconnected from the supply		P
	Electric strength tests according to table 4 .....	(see appended table)	P
	No breakdown during the tests		P
<b>14</b>	<b>TRANSIENT OVERVOLTAGES</b>		<b>N/A</b>
	Appliances withstand the transient over-voltages to which they may be subjected		N/A
	Clearances having a value less than specified in table 16 subjected to an impulse voltage test, the test voltage specified in table 6 .....		N/A
	No flashover during the test, unless		N/A
	of functional insulation if the appliance complies with clause 19 with the clearance short-circuited		N/A
<b>15</b>	<b>MOISTURE RESISTANCE</b>		<b>P</b>
15.1	Enclosure provides the degree of moisture protection according to classification of the appliance	IP20	N/A

IEC 60335-2-29			
Clause	Requirement + Test	Result - Remark	Verdict
	Compliance checked as specified in 15.1.1, taking into account 15.1.2, followed by the electric strength test of 16.3		N/A
	No trace of water on insulation which can result in a reduction of clearances or creepage distances below values specified in clause 29		N/A
15.1.1	Appliances, other than IPX0, subjected to tests as specified in IEC 60529 .....		N/A
	Water valves containing live parts in external hoses for connection of an appliance to the water mains tested as specified for IPX7 appliances		N/A
15.1.2	Hand-held appliance turned continuously through the most unfavourable positions during the test		N/A
	Built-in appliances installed according to the instructions		N/A
	Appliances placed or used on the floor or table placed on a horizontal unperforated support		N/A
	Appliances normally fixed to a wall and appliances with pins for insertion into socket-outlets are mounted on a wooden board		N/A
	For IPX3 appliances, the base of wall mounted appliances is placed at the same level as the pivot axis of the oscillating tube		N/A
	For IPX4 appliances, the horizontal centre line of the appliance is aligned with the pivot axis of the oscillating tube, and		N/A
	for appliances normally used on the floor or table, the movement is limited to two times 90° for a period of 5 min, the support being placed at the level of the pivot axis of the oscillating tube		N/A
	Wall-mounted appliances, take into account the distance to the floor stated in the instructions		N/A
	Appliances normally fixed to a ceiling are mounted underneath a horizontal unperforated support, the pivot axis of the oscillating tube located at the level of the underside of the support, and		N/A
	for IPX4 appliances, the movement of the tube is limited to two times 90° from the vertical for a period of 5 min		N/A

<b>IEC 60335-2-29</b>			
Clause	Requirement + Test	Result - Remark	Verdict
	Appliances with type X attachment fitted with a flexible cord as described		N/A
	Detachable parts subjected to the relevant treatment with the main part		N/A
	However, if a part has to be removed for user maintenance and a tool is needed, this part is not removed		N/A
15.2	Spillage of liquid does not affect the electrical insulation		N/A
	Appliances with type X attachment fitted with a flexible cord as described		N/A
	Appliances incorporating an appliance inlet tested with or without an connector, whichever is most unfavourable		N/A
	Detachable parts are removed		N/A
	Overfilling test with additional amount of water, over a period of 1 min (l) .....		N/A
	The appliance withstands the electric strength test of 16.3		N/A
	No trace of water on insulation that can result in a reduction of clearances or creepage distances below values specified in clause 29		N/A
15.3	Appliances proof against humid conditions	30°C, 93%RH	P
	Checked by test Cab: Damp heat steady state in IEC 60068-2-78		P
	Detachable parts removed and subjected, if necessary, to the humidity test with the main part	No detachable part.	N/A
	Humidity test for 48 h in a humidity cabinet		P
	Reassembly of those parts that may have been removed	No such part.	N/A
	The appliance withstands the tests of clause 16		P
<b>16</b>	<b>LEAKAGE CURRENT AND ELECTRIC STRENGTH</b>		<b>P</b>
16.1	Leakage current not excessive and electric strength adequate		P
	Protective impedance disconnected from live parts before carrying out the tests		N/A
	Tests carried out at room temperature and not connected to the supply		P

<b>IEC 60335-2-29</b>			
Clause	Requirement + Test	Result - Remark	Verdict
16.2	Single-phase appliances: test voltage 1,06 times rated voltage (V) .....	240 X 1,06 = 254,4 Vac	P
	Three-phase appliances: test voltage 1,06 times rated voltage divided by $\sqrt{3}$ (V) .....		N/A
	Leakage current measurements .....	(see appended table)	P
	Limit values doubled if:		—
	- all controls have an off position in all poles, or		N/A
	- the appliance has no control other than a thermal cut-out, or		N/A
	- all thermostats, temperature limiters and energy regulators do not have an off position, or		N/A
	- the appliance has radio interference filters		N/A
	With the radio interference filters disconnected, the leakage current do not exceed limits specified .....		N/A
16.3	Electric strength tests according to table 7 .....	(see appended table)	P
	Test voltage applied between the supply cord and inlet bushing and cord guard and cord anchorage as specified .....	(see appended table)	P
	No breakdown during the tests		P
17	<b>OVERLOAD PROTECTION OF TRANSFORMERS AND ASSOCIATED CIRCUITS</b>		P
	No excessive temperatures in transformer or associated circuits in event of short-circuits likely to occur in normal use .....	(see appended table)	P
	Appliance supplied with 1,06 or 0,94 times rated voltage under the most unfavourable short-circuit or overload likely to occur in normal use (V) .....		P
	Output terminals of battery chargers are short-circuited (IEC 60335-2-29)		P
	Basic insulation is not short-circuited		P
	Temperature rise of insulation of the conductors of safety extra-low voltage circuits not exceeding the relevant value specified in table 3 by more than 15 K		P
	Temperature of the winding not exceeding the value specified in table 8		P

IEC 60335-2-29			
Clause	Requirement + Test	Result - Remark	Verdict
	However, limits do not apply to fail-safe transformers complying with sub-clause 15.5 of IEC 61558-1		N/A
18	ENDURANCE		N/A
	Requirements and tests are specified in part 2 when necessary		N/A
19	ABNORMAL OPERATION		P
19.1	The risk of fire, mechanical damage or electric shock under abnormal or careless operation obviated		P
	Electronic circuits so designed and applied that a fault will not render the appliance unsafe .....	(see appended table)	P
	if the appliance also has a control that limit the temperature during clause 11 it is subjected to the test of 19.4, and		N/A
	Appliances incorporating motors subjected to the tests of 19.7 to 19.10, as applicable		N/A
	Appliances incorporating electronic circuits subjected to the tests of 19.11 and 19.12, as applicable		N/A
	Appliances incorporating contactors or relays subjected to the test of 19.14, being carried out before the tests of 19.11		N/A
19.2	Test of appliances with heating elements with restricted heat dissipation; test voltage (V), power input of 0.85 times rated power input (W) .....	No such appliance	N/A
19.3	Test of 19.2 repeated; test voltage (V), power input of 1,24 times rated power input (W) .....	No such appliance	N/A
19.4	Test conditions as in clause 11, any control limiting the temperature during tests of clause 11 short-circuited		N/A
19.5	Test of 19.4 repeated on Class 0I and I appliances with tubular sheathed or embedded heating elements. No short-circuiting, but one end of the element connected to the sheath		N/A
	The test repeated with reversed polarity and the other end of the heating element connected to the sheath		N/A

IEC 60335-2-29			
Clause	Requirement + Test	Result - Remark	Verdict
	The test is not carried out on appliances intended to be permanently connected to fixed wiring and on appliances where an all-pole disconnection occurs during the test of 19.4		N/A
19.6	Appliances with PTC heating elements tested at rated voltage, establishing steady conditions		N/A
	The working voltage of the PTC heating element is increased by 5% and the appliance is operated until steady conditions are re-established. The voltage is then increased in similar steps until 1.5 times working voltage or until the PTC heating element ruptures (V) .....		N/A
19.7	Stalling test by locking the rotor if the locked rotor torque is smaller than the full load torque, or		N/A
	locking moving parts of other appliances		N/A
	Locked rotor, capacitors open-circuited one at a time		N/A
	Test repeated with capacitors short-circuited one at a time, unless		N/A
	capacitor is of class P2 of IEC 60252-1		N/A
	Appliances with timer or programmer supplied with rated voltage for each of the tests, for a period equal to the maximum period allowed.....		N/A
	Other appliances supplied with rated voltage for a period as specified .....		N/A
	Winding temperatures not exceeding values specified in table 8.....		N/A
19.8	Multi-phase motors operated at rated voltage with one phase disconnected		N/A
19.9	Running overload test on appliances incorporating motors intended to be remotely or automatically controlled or liable to be operated continuously		N/A
	Motor-operated and combined appliances for which 30.2.3 is applicable and that use overload protective devices relying on electronic circuits to protect the motor windings, are also subjected to the test		N/A
	Winding temperatures not exceeding values as specified .....		N/A

IEC 60335-2-29			
Clause	Requirement + Test	Result - Remark	Verdict
19.10	Series motor operated at 1,3 times rated voltage for 1 min (V) .....		N/A
	During the test, parts not being ejected from the appliance		N/A
19.11	Electronic circuits, compliance checked by evaluation of the fault conditions specified in 19.11.2 for all circuits or parts of circuits, unless		P
	they comply with the conditions specified in 19.11.1		P
	Appliances incorporating an electronic circuit that relies upon a programmable component to function correctly, subjected to the test of 19.11.4.8, unless		N/A
	restarting does not result in a hazard		P
	Appliances having a device with an off position obtained by electronic disconnection, or a device placing the appliance in a stand-by mode, subjected to the tests of 19.11.4		N/A
	If the safety of the appliance under any of the fault conditions depends on the operation of a miniature fuse-link complying with IEC 60127, the test of 19.12 is carried out		N/A
	During and after each test the following is checked:		P
	- the temperature of the windings do not exceed the values specified in table 8		P
	- the appliance complies with the conditions specified in 19.13		P
	- any current flowing through protective impedance not exceeding the limits specified in 8.1.4		P
	If a conductor of a printed board becomes open-circuited, the appliance is considered to have withstood the particular test, provided both of the following conditions are met:		—
	- the base material of the printed circuit board withstands the test of Annex E		N/A
	- any loosened conductor does not reduce clearance or creepage distances between live parts and accessible metal parts below the values specified in clause 29		N/A
19.11.1	Fault conditions a) to g) in 19.11.2 are not applied to circuits or parts of circuits meeting both of the following conditions:		—

IEC 60335-2-29			
Clause	Requirement + Test	Result - Remark	Verdict
	- the electronic circuit is a low-power circuit, that is, the maximum power at low-power points does not exceed 15 W according to the tests specified		N/A
	- the protection against electric shock, fire hazard, mechanical hazard or dangerous malfunction of other parts of the appliance does not rely on the correct functioning of the electronic circuit		N/A
19.11.2	Fault conditions applied one at a time, the appliance operating under conditions specified in clause 11, but supplied at rated voltage, duration of the tests as specified:		—
	a) short circuit of functional insulation if clearances or creepage distances are less than the values specified in clause 29		N/A
	b) open circuit at the terminals of any component	For component: D5	P
	c) short circuit of capacitors, unless		P
	they comply with IEC 60384-14		N/A
	d) short circuit of any two terminals of an electronic component, other than integrated circuits	For components: U2 pin2-3, U2 pin2-4, U2 pin8-5, D1, D7	P
	This fault condition is not applied between the two circuits of an optocoupler		N/A
	e) failure of triacs in the diode mode		P
	f) failure of microprocessors and integrated circuits		P
	g) failure of an electronic power switching device		N/A
	Each low power circuit is short-circuited by connecting the low-power point to the pole of the supply source from which the measurements were made		N/A
19.11.3	If the appliance incorporates a protective electronic circuit which operates to ensure compliance with clause 19, the relevant test is repeated with a single fault simulated, as indicated in a) to g) of 19.11.2		P
19.11.4	Appliances having a device with an off position obtained by electronic disconnection, or		N/A
	a device that can be placed in the stand-by mode,		N/A
	subjected to the tests of 19.11.4.1 to 19.11.4.7, the device being set in the off position or in the stand-by mode		N/A

IEC 60335-2-29			
Clause	Requirement + Test	Result - Remark	Verdict
	Appliances incorporating a protective electronic circuit subjected to the tests of 19.11.4.1 to 19.11.4.7, the tests being carried out after the protective electronic circuit has operated, except that		N/A
	appliances operated for 30 s or 5 min during the test of 19.7 are not subjected to the tests for electromagnetic phenomena.		N/A
	Surge protective devices disconnected, unless		N/A
	They incorporate spark gaps		N/A
19.11.4.1	The appliance is subjected to electrostatic discharges in accordance with IEC 61000-4-2, test level 4		N/A
19.11.4.2	The appliance is subjected to radiated fields in accordance with IEC 61000-4-3, test level 3		N/A
19.11.4.3	The appliance is subjected to fast transient bursts in accordance with IEC 61000-4-4, test level 3 or 4 as specified		N/A
19.11.4.4	The power supply terminals of the appliance subjected to voltage surges in accordance with IEC 61000-4-5, test level 3 or 4 as specified		N/A
	Earthed heating elements in class I appliances disconnected		N/A
19.11.4.5	The appliance is subjected to injected currents in accordance with IEC 61000-4-6, test level 3		N/A
19.11.4.6	Appliances having a rated current not exceeding 16 A are subjected to the Class 3 voltage dips and interruptions in accordance with IEC 61000-4-11		N/A
	Appliances having a rated current exceeding 16 A are subjected to the Class 3 voltage dips and interruptions in accordance with IEC 61000-4-34		N/A
19.11.4.7	The appliance is subjected to mains signals in accordance with IEC 61000-4-13, test level class 2		N/A
19.11.4.8	The appliance is supplied at rated voltage and operated under normal operation. After 60s the power supply is reduced to a level such that the appliance ceases to respond or parts controlled by the programmable component cease to operate		N/A
	The appliance continues to operate normally, or		N/A
	requires a manual operation to restart		N/A

IEC 60335-2-29			
Clause	Requirement + Test	Result - Remark	Verdict
19.12	If the safety of the appliance for any of the fault conditions specified in 19.11.2 depends on the operation of a miniature fuse-link complying with IEC 60127, the test is repeated, measuring the current flowing through the fuse-link; measured current (A); rated current of the fuse-link (A).....:		N/A
19.13	During the tests the appliance does not emit flames, molten metal, poisonous or ignitable gas in hazardous amounts		P
	Temperature rises not exceeding the values shown in table 9 .....		P
	During the tests, the values of Table 8 apply (IEC 60335-2-29)	( see appended table)	P
	Compliance with clause 8 not impaired	( see appended table)	P
	No rupture of the battery (IEC 60335-2-29/A2)		N/A
	If the appliance can still be operated it complies with 20.2		N/A
	Insulation, other than of class III appliances or class III constructions that do not contain live parts, withstands the electric strength test of 16.3, the test voltage as specified in table 4:		—
	- basic insulation (V).....:		P
	- supplementary insulation (V) .....		N/A
	- reinforced insulation (V) .....		P
	After operation or interruption of a control, clearances and creepage distances across the functional insulation withstand the electric strength test of 16.3, the test voltage being twice the working voltage		N/A
	The appliance does not undergo a dangerous malfunction, and		P
	no failure of protective electronic circuits, if the appliance is still operable		N/A
	Appliances tested with an electronic switch in the off position, or in the stand-by mode:		—
	- do not become operational, or		N/A
	- if they become operational, do not result in a dangerous malfunction during or after the tests of 19.11.4		N/A

IEC 60335-2-29			
Clause	Requirement + Test	Result - Remark	Verdict
	If the appliance contains lids or doors that are controlled by one or more interlocks, one of the interlocks may be released provided that:		—
	- the lid or door does not move automatically to an open position when the interlock is released, and		N/A
	- the appliance does not start after the cycle in which the interlock was released		N/A
19.14	Appliances operated under the conditions of clause 11, any contactor or relay contact operating under the conditions of clause 11 being short-circuited		N/A
	For a relay or contactor with more than one contact, all contacts are short-circuited at the same time		N/A
	A relay or contactor operating only to ensure the appliance is energized for normal use is not short-circuited		N/A
	If more than one relay or contactor operates in clause 11, they are short-circuited in turn		N/A
19.15	For appliances with a mains voltage selector switch, the switch is set to the lowest rated voltage position and the highest value of rated voltage is applied		N/A
19.101	Battery chargers supplied at rated voltage and operated under normal operation, any control limiting the temperature during tests of clause 11 short-circuited (IEC 60335-2-29)		N/A
19.102	Reverse connection of battery chargers to a fully charged battery at rated voltage (IEC 60335-2-29)	Polarized output connector provided by battery charger	P
	The capacity of the battery (IEC 60335-2-29) .....	550 mAH for testing	P
19.103	Battery chargers intended to be used with a d.c. distribution board supplied at rated voltage and operated under normal operation, load increased as specified until protective device operates or short-circuit conditions are established (IEC 60335-2-29)		N/A
20	<b>STABILITY AND MECHANICAL HAZARDS</b>		<b>P</b>
20.1	Appliances having adequate stability		N/A
	Tilting test through an angle of 10°, appliance placed on an inclined plane/horizontal support, not connected to the supply mains; appliance does not overturn		N/A

IEC 60335-2-29			
Clause	Requirement + Test	Result - Remark	Verdict
	Tilting test repeated on appliances with heating elements, angle of inclination increased to 15°		N/A
	Possible heating test in overturned position; temperature rise does not exceed values shown in table 9		N/A
20.2	Moving parts adequately arranged or enclosed as to provide protection against personal injury	No moving parts	N/A
	Protective enclosures, guards and similar parts are non-detachable, and		N/A
	have adequate mechanical strength		N/A
	Enclosures that can be opened by overriding an interlock are considered to be detachable parts		N/A
	Self-resetting thermal cut-outs and overcurrent protective devices not causing a hazard by unexpected closure		N/A
	Not possible to touch dangerous moving parts with the test probe described		N/A
21	<b>MECHANICAL STRENGTH</b>		<b>P</b>
21.1	Appliance has adequate mechanical strength and is constructed as to withstand rough handling		P
	Checked by applying 3 blows to every point of the enclosure like to be weak, in accordance with test Ehb of IEC 60068-2-75, spring hammer test, with an impact energy of 1,0 J ± 0,05 J (IEC 60335-2-29)	No deformation or crack of enclosure after tests	P
	The appliance shows no damage impairing compliance with this standard, and		P
	compliance with 8.1, 15.1 and clause 29 not impaired		P
	If doubt, supplementary or reinforced insulation subjected to the electric strength test of 16.3		N/A
	If necessary, repetition of groups of three blows on a new sample		N/A
21.2	Accessible parts of solid insulation having strength to prevent penetration by sharp implements		N/A
	Test not applicable if the thickness of supplementary insulation is at least 1 mm and reinforced insulation at least 2 mm		N/A

IEC 60335-2-29			
Clause	Requirement + Test	Result - Remark	Verdict
	The insulation is tested as specified, and does withstand the electric strength test of 16.3		N/A
21.101	Battery chargers, other than built-in battery chargers, having a mass not exceeding 5 kg, subjected to a drop test (IEC 60335-2-29)	0,06 kg	P
	Battery chargers show no damage that could impair compliance with 8.1, 15.1.1, 16.3 and cl. 29 (IEC 60335-2-29)		P
21.102	Battery chargers for installing in caravans and similar vehicles withstand vibrations to which they may be subjected (IEC 60335-2-29)	The battery charger is not such a application	N/A
	Vibration test as specified in IEC 60068-2-6 (IEC 60335-2-29)		N/A
	Battery chargers show no damage that could impair compliance with 8.1, 15.1.1, 16.3 and cl. 29 (IEC 60335-2-29)		N/A
	Connections have not worked loose (IEC 60335-2-29)		N/A
22	<b>CONSTRUCTION</b>		<b>P</b>
22.1	Appliance marked with the first numeral of the IP system, relevant requirements of IEC 60529 are fulfilled	IP X0	N/A
22.2	Stationary appliance: means to ensure all-pole disconnection from the supply being provided:		N/A
	- a supply cord fitted with a plug, or		N/A
	- a switch complying with 24.3, or		N/A
	- a statement in the instruction sheet that a disconnection incorporated in the fixed wiring is to be provided, or		N/A
	- an appliance inlet		N/A
	Single-pole switches and single-pole protective devices for the disconnection of heating elements in single-phase, permanently connected class 01 and class I appliances, connected to the phase conductor		N/A
22.3	Appliance provided with pins: no undue strain on socket-outlets		N/A
	Applied torque not exceeding 0,25 Nm		N/A

IEC 60335-2-29			
Clause	Requirement + Test	Result - Remark	Verdict
	Pull force of 50 N to each pin after the appliance has being placed in the heating cabinet; when cooled to room temperature the pins are not displaced by more than 1 mm		N/A
	Each pin subjected to a torque of 0,4 Nm; the pins are not rotating, unless		N/A
	rotating does not impair compliance with this standard		N/A
22.4	Appliance for heating liquids and appliance causing undue vibration not provided with pins for insertion into socket-outlets		N/A
22.5	No risk of electric shock when touching the pins of the plug, for appliances having a capacitor with rated capacitance exceeding 0,1 $\mu$ F, the appliance being disconnected from the supply at the instant of voltage peak	No capacitor used in primary circuit	N/A
	Voltage not exceeding 34 V (V) .....		N/A
22.6	Electrical insulation not affected by condensing water or leaking liquid		N/A
	Electrical insulation of Class II appliances not affected if a hose ruptures or seal leaks		N/A
	In case of doubt, test as described		N/A
22.7	Adequate safeguards against the risk of excessive pressure in appliances containing liquid or gases or having steam-producing devices		N/A
22.8	Electrical connections not subject to pulling during cleaning of compartments to which access can be gained without the aid of a tool, and that are likely to be cleaned in normal use		N/A
22.9	Insulation, internal wiring, windings, commutators and slip rings not exposed to oil, grease or similar substances, unless	No oil, grease or similar substances used inside of enclosure	P
	the substance has adequate insulating properties		P
22.10	Not possible to reset voltage-maintained non-self-resetting thermal cut-outs by the operation of an automatic switching device incorporated within the appliance, if:	No such reset parts	N/A
	- a non-self-resetting thermal cut-out is required by the standard, and		N/A

IEC 60335-2-29			
Clause	Requirement + Test	Result - Remark	Verdict
	- a voltage maintained non-self-resetting thermal cut-out is used to meet it		N/A
	Non-self-resetting thermal motor protectors have a trip-free action, unless		N/A
	they are voltage maintained		N/A
	Reset buttons of non-self-resetting controls so located or protected that accidental resetting is unlikely		N/A
22.11	Reliable fixing of non-detachable parts that provide the necessary degree of protection against electric shock, moisture or contact with moving parts	No parts can be detachable. The enclosure secured well by ultrasonic welding.	P
	Obvious locked position of snap-in devices used for fixing such parts		N/A
	No deterioration of the fixing properties of snap-in devices used in parts that are likely to be removed during installation or servicing		N/A
	Tests as described		P
22.12	Handles, knobs etc. fixed in a reliable manner		N/A
	Fixing in wrong position of handles, knobs etc. indicating position of switches or similar components not possible		N/A
	Axial force 15 N applied to parts, the shape being so that an axial pull is unlikely to be applied		N/A
	Axial force 30 N applied to parts, the shape being so that an axial pull is likely to be applied		N/A
22.13	Unlikely that handles, when gripped as in normal use, make the operator's hand touch parts having a temperature rise exceeding the value specified for handles which are held for short periods only	The temperature rise not exceeding the specified value	P
22.14	No ragged or sharp edges creating a hazard for the user in normal use, or during user maintenance	The external surface of the enclosure is smoothed	P
	No exposed pointed ends of self-tapping screws or other fasteners, likely to be touched by the user in normal use or during user maintenance		P
22.15	Storage hooks and the like for flexible cords smooth and well rounded	No such device	N/A

IEC 60335-2-29			
Clause	Requirement + Test	Result - Remark	Verdict
22.16	Automatic cord reels cause no undue abrasion or damage to the sheath of the flexible cord, no breakage of conductors strands and no undue wear of contacts	Not have such parts	N/A
	Cord reel tested with 6000 operations, as specified		N/A
	Electric strength test of 16.3, voltage of 1000 V applied		N/A
22.17	Spacers not removable from the outside by hand or by means of a screwdriver or a spanner		N/A
22.18	Current-carrying parts and other metal parts resistant to corrosion		P
22.19	Driving belts not relied upon to provide the required level of insulation, unless	No such parts	N/A
	constructed to prevent inappropriate replacement		N/A
22.20	Direct contact between live parts and thermal insulation effectively prevented, unless		N/A
	material used is non-corrosive, non-hygroscopic and non-combustible		N/A
22.21	Wood, cotton, silk, ordinary paper and fibrous or hygroscopic material not used as insulation, unless		P
	impregnated		N/A
	This requirement does not apply to magnesium oxide and mineral ceramic fibres used for the electrical insulation of heating elements		N/A
22.22	Appliances not containing asbestos		P
22.23	Oils containing polychlorinated biphenyl (PCB) not used		P
22.24	Bare heating elements, except in class III appliances or class III constructions that do not contain live parts, adequately supported	No such parts	N/A
	In case of rupture, the heating conductor is unlikely to come in contact with accessible metal parts		N/A
22.25	Sagging heating conductors, except in class III appliances or class III constructions that do not contain live parts, cannot come into contact with accessible metal parts		N/A
22.26	Output circuit supplied through a safety isolating transformer (IEC 60335-2-29)		P

IEC 60335-2-29			
Clause	Requirement + Test	Result - Remark	Verdict
	No connection between the output circuit and accessible metal parts or an earthing terminal (IEC 60335-2-29)		P
	Insulation between parts operating at safety extra-low voltage and live parts complies with the requirements for double or reinforced insulation (IEC 60335-2-29)		P
22.27	Parts connected by protective impedance separated by double or reinforced insulation	Two Y1 (2,2 nF) capacitors used in series at CY1, CY2	P
22.28	Metal parts of Class II appliances conductively connected to gas pipes or in contact with water, separated from live parts by double or reinforced insulation		N/A
22.29	Class II appliances permanently connected to fixed wiring so constructed that the required degree of access to live parts is maintained after installation		N/A
22.30	Parts serving as supplementary or reinforced insulation fixed so that they cannot be removed without being seriously damaged, or		P
	so constructed that they cannot be replaced in an incorrect position, and so that if they are omitted, the appliance is rendered inoperable or manifestly incomplete		P
22.31	Neither clearances nor creepage distances over supplementary and reinforced insulation reduced below values specified in clause 29 as a result of wear		P
	Neither clearances nor creepage distances between live parts and accessible parts reduced below values for supplementary insulation if wires, screws etc. become loose	The enclosure secured well by ultrasonic welding	P
22.32	Supplementary and reinforced insulation constructed or protected against pollution so that clearances or creepage distances are not reduced below the values in clause 29		P
	Supplementary insulation of natural or synthetic rubber resistant to ageing, or arranged and dimensioned so that creepage distances are not reduced below values specified in 29.2		N/A
	Ceramic material not tightly sintered, similar materials or beads alone not used as supplementary or reinforced insulation		N/A

IEC 60335-2-29			
Clause	Requirement + Test	Result - Remark	Verdict
	Insulating material in which heating conductors are embedded is considered to be basic insulation, not reinforced insulation		N/A
	Oxygen bomb test at 70 °C for 96 h and 16 h at room temperature		N/A
22.33	Conductive liquids that are or may become accessible in normal use and conductive liquids that are in contact with unearthed accessible metal parts are not in direct contact with live parts	No such conductive liquids	N/A
	Electrodes not used for heating liquids		N/A
	For class II constructions, conductive liquids that are or may become accessible in normal use and conductive liquids that are in contact with unearthed accessible metal parts, not in direct contact with basic or reinforced insulation, unless		N/A
	the reinforced insulation consists of at least 3 layers		N/A
	For class II constructions, conductive liquids which are in contact with live parts, not in direct contact with reinforced insulation, unless		N/A
	the reinforced insulation consists of at least 3 layers		N/A
	An air layer not used as basic or supplementary insulation in a double insulation system if likely to be bridged by leaking liquid		N/A
22.34	Shafts of operating knobs, handles, levers etc. not live, unless	No such shafts	N/A
	the shaft is not accessible when the part is removed		N/A
22.35	For other than class III constructions, handles, levers and knobs, held or actuated in normal use, not becoming live in the event of a failure of basic insulation		N/A
	Such parts being of metal, and their shafts or fixings are likely to become live in the event of a failure of basic insulation, are either adequately covered by insulation material or their accessible parts are separated from their shafts or fixings by supplementary insulation		N/A

IEC 60335-2-29			
Clause	Requirement + Test	Result - Remark	Verdict
	This requirement does not apply to handles, levers and knobs on stationary appliances, other than those of electrical components, provided they are reliably connected to an earthing terminal or earthing contact, or separated from live parts by earthed metal		N/A
	Insulating material covering metal handles, levers and knobs withstand the electric strength test of 16.3 for supplementary insulation		N/A
22.36	For appliances other than class III, handles continuously held in the hand in normal use so constructed that when gripped as in normal use, the operators hand is not likely to touch metal parts, unless		N/A
	they are separated from live parts by double or reinforced insulation		N/A
22.37	Capacitors in Class II appliances not connected to accessible metal parts and their casings, if of metal, separated from accessible metal parts by supplementary insulation, unless		P
	the capacitors comply with 22.42		P
22.38	Capacitors not connected between the contacts of a thermal cut-out		P
22.39	Lamp holders used only for the connection of lamps		N/A
22.40	Motor-operated appliances and combined appliances intended to be moved while in operation, or having accessible moving parts, fitted with a switch to control the motor. The actuating member of the switch being easily visible and accessible		N/A
	If the appliance cannot operate continuously, automatically or remotely without giving rise to a hazard, appliances for remote operation being fitted with a switch for stopping the operation. The actuating member of the switch being easily visible and accessible		N/A
22.41	No components, other than lamps, containing mercury		P
22.42	Protective impedance consisting of at least two separate components	Two Y1 (2,2 nF) capacitors used in series at CY1, CY2	P

IEC 60335-2-29			
Clause	Requirement + Test	Result - Remark	Verdict
	Values specified in 8.1.4 not exceeded if any one of the components are short-circuited or open-circuited	0,276 mA <sub>peak</sub> max. < 0,7 mA <sub>peak</sub>	P
	Resistors checked by the test of 14.1 a) in IEC 60065		N/A
	Capacitors checked by the tests for class Y capacitors in IEC 60384-14		P
22.43	Appliances adjustable for different voltages, accidental changing of the setting of the voltage unlikely to occur		N/A
22.44	Appliances not having an enclosure that is shaped or decorated like a toy		P
22.45	When air is used as reinforced insulation, clearances not reduced below the values specified in 29.1.3 due to deformation as a result of an external force applied to the enclosure		N/A
22.46	For programmable protective electronic circuits used to ensure compliance with the standard, the software contains measures to control the fault/error conditions in table R.1		N/A
	Software that contains measures to control the fault/error conditions specified in table R.2 is to be specified in parts 2 for particular constructions or to address specific hazards		N/A
	These requirements are not applicable to software used for functional purpose or compliance with clause 11		N/A
22.47	Appliances connected to the water mains withstand the water pressure expected in normal use		N/A
	No leakage from any part, including any inlet water hose		N/A
22.48	Appliances connected to the water mains constructed to prevent backsiphonage of non-potable water		N/A
22.49	For remote operation, the duration of operation is to be set before the appliance can be started, unless		N/A
	the appliance switches off automatically or can operate continuously without hazard		N/A
22.50	Controls incorporated in the appliance take priority over controls actuated by remote operation		N/A

IEC 60335-2-29			
Clause	Requirement + Test	Result - Remark	Verdict
22.51	There is a control on the appliance manually adjusted to the setting for remote operation before the appliance can be operated in this mode		N/A
	There is a visual indication showing that the appliance is adjusted for remote operation		N/A
	These requirements not necessary on appliances that can operate as follows, without giving rise to a hazard:		—
	- continuously, or		N/A
	- automatically, or		N/A
	- remotely		N/A
22.52	Socket-outlets on appliances accessible to the user in accordance with the socket-outlet system used in the country in which the appliance is sold		N/A
22.102	Each circuit supplied from a d.c. distribution board incorporates an overload protective device (IEC 60335-2-29)		N/A
22.103	Battery chargers for installing in caravans or similar vehicles constructed so that they can be securely fixed to a support (IEC 60335-2-29)		N/A
23	<b>INTERNAL WIRING</b>		P
23.1	Wireways smooth and free from sharp edges		P
	Wires protected against contact with burrs, cooling fins etc.		P
	Wire holes in metal well-rounded or provided with bushings		N/A
	Wiring effectively prevented from coming into contact with moving parts	No moving parts	P
23.2	Beads etc. on live wires cannot change their position, and are not resting on sharp edges	No such beads etc.	P
	Beads inside flexible metal conduits contained within an insulating sleeve		N/A
23.3	Electrical connections and internal conductors movable relatively to each other not exposed to undue stress		P
	Flexible metallic tubes not causing damage to insulation of conductors		N/A
	Open-coil springs not used	No such parts	N/A

IEC 60335-2-29			
Clause	Requirement + Test	Result - Remark	Verdict
	Adequate insulating lining provided inside a coiled spring, the turns of which touch one another		N/A
	No damage after 10 000 flexings for conductors flexed during normal use, or		N/A
	100 flexings for conductors flexed during user maintenance		N/A
	Electric strength test of 16.3, 1000 V between live parts and accessible metal parts		N/A
	Not more than 10% of the strands of any conductor broken, and		N/A
	not more than 30% for wiring supplying circuits that consume no more than 15W		N/A
23.4	Bare internal wiring sufficiently rigid and fixed	Power cord was soldered on PCB and fixed by glue	P
23.5	The insulation of internal wiring subjected to the supply mains voltage withstanding the electrical stress likely to occur in normal use	No such wiring for connecting supply voltage	N/A
	Basic insulation electrically equivalent to the basic insulation of cords complying with IEC 60227 or IEC 60245, or		N/A
	no breakdown when a voltage of 2000 V is applied for 15 min between the conductor and metal foil wrapped around the insulation		N/A
23.6	Sleeving used as supplementary insulation on internal wiring retained in position by clamping at both ends, or		N/A
	be such that it can only be removed by breaking or cutting		N/A
23.7	The colour combination green/yellow only used for earthing conductors		N/A
23.8	Aluminium wires not used for internal wiring		P
23.9	Stranded conductors not consolidated by soldering where they are subjected to contact pressure, unless		N/A
	the contact pressure is provided by spring terminals		N/A

IEC 60335-2-29			
Clause	Requirement + Test	Result - Remark	Verdict
23.10	The insulation and sheath of internal wiring, incorporated in external hoses for the connection of an appliance to the water mains, at least equivalent to that of light polyvinyl chloride sheathed flexible cord (60227 IEC 52)		N/A
24	COMPONENTS		P
24.1	Components comply with safety requirements in relevant IEC standards		P
	List of components .....	(see appended table)	P
	If components have not been tested and found to comply with relevant IEC standard for the number of cycles specified, they are tested in accordance with 24.1.1 to 24.1.9		P
	For components mentioned in 24.1.1 to 24.1.9 no additional tests specified in the relevant component standard are necessary other than those specified in 24.1.1 to 24.1.9		P
	Components not tested and found to comply with relevant IEC standard and components not marked or not used in accordance with its marking, tested under the conditions occurring in the appliance		P
	Lampholders and starterholders that have not being tested and found to comply with the relevant IEC standard, tested as a part of the appliance and additionally according to the gauging and interchangeability requirements of the relevant IEC standard		N/A
	No additional tests specified for nationally standardized plugs such as those detailed in IEC/TR 60083 or connectors complying with the standard sheets of IEC 60320-1 and IEC 60309		N/A
24.1.1	Capacitors likely to be permanently subjected to the supply voltage and used for radio interference suppression or for voltage dividing, complying with IEC 60384-14		P
	If the capacitors have to be tested, they are tested according to Annex F		N/A
24.1.2	Safety isolating transformers complying with IEC 61558-2-6		N/A
	If they have to be tested, they are tested according to Annex G		P

IEC 60335-2-29			
Clause	Requirement + Test	Result - Remark	Verdict
24.1.3	Switches complying with IEC 61058-1, the number of cycles of operation being at least 10 000		N/A
	If they have to be tested, they are tested according to Annex H		N/A
	If the switch operates a relay or contactor, the complete switching system is subjected to the test		N/A
	If the switch only operates a motor starting relay complying with IEC 60730-2-10 with the number of cycles of a least 10 000 as specified, the complete switching system need not be tested		N/A
24.1.4	Automatic controls complying with IEC 60730-1 with the relevant part 2. The number of cycles of operation being at least:		—
	- thermostats: 10 000		N/A
	- temperature limiters: 1 000		N/A
	- self-resetting thermal cut-outs: 300		N/A
	- voltage maintained non-self-resetting thermal cut-outs: 1 000		N/A
	- other non-self-resetting thermal cut-outs: 30		N/A
	- timers: 3 000		N/A
	- energy regulators: 10 000		N/A
	The number of cycles for controls operating during clause 11 need not be declared, if the appliance meets the requirements of this standard when they are short-circuited		N/A
	Thermal motor protectors are tested in combination with their motor under the conditions specified in Annex D		N/A
	For water valves containing live parts and that are incorporated in external hoses for connection of an appliance to the water mains, the degree of protection declared for subclause 6.5.2 of IEC 60730-2-8 is IPX7		N/A
24.1.5	Appliance couplers complying with IEC 60320-1		N/A
	However, for appliances classified higher than IPX0, the appliance couplers complying with IEC 60320-2-3		N/A
	Interconnection couplers complying with IEC 60320-2-2		N/A

IEC 60335-2-29			
Clause	Requirement + Test	Result - Remark	Verdict
24.1.6	Small lamp holders similar to E10 lampholders complying with IEC 60238, the requirements for E10 lampholders being applicable		N/A
24.1.7	For remote operation of the appliance via a telecommunication network, the relevant standard for the telecommunication interface circuitry in the appliance is IEC 62151		N/A
24.1.8	The relevant standard for thermal links is IEC 60691		N/A
	Thermal links not complying with IEC 60691 are considered to be an intentionally weak part for the purposes of Clause 19		N/A
24.1.9	Contactors and relays, other than motor starting relays, tested as part of the appliance		N/A
	They are also tested in accordance with Clause 17 of IEC 60730-1, the number of cycles of operations in 24.1.4 selected according to the contactor or relay function in the appliance.....:		N/A
24.2	Appliances not fitted with:		—
	- switches or automatic controls in flexible cords		N/A
	- devices causing the protective device in the fixed wiring to operate in the event of a fault in the appliance		N/A
	- thermal cut-outs that can be reset by soldering, unless		N/A
	the solder has a melting point of at least 230 °C		N/A
24.3	Switches intended for all-pole disconnection of stationary appliances are directly connected to the supply terminals and have a contact separation in all poles, providing full disconnection under overvoltage category III conditions		N/A
24.4	Plugs and socket-outlets for extra-low voltage circuits and heating elements, not interchangeable with plugs and socket-outlets listed in IEC/TR 60083 or IEC 60906-1 or with connectors and appliance inlets complying with the standard sheets of IEC 60320-1		N/A
24.5	Capacitors in auxiliary windings of motors marked with their rated voltage and capacitance, and used accordingly		N/A

IEC 60335-2-29			
Clause	Requirement + Test	Result - Remark	Verdict
	Voltage across capacitors in series with a motor winding does not exceed 1,1 times rated voltage, when the appliance is supplied at 1,1 times rated voltage under minimum load		N/A
24.6	Working voltage of motors connected to the supply mains and having basic insulation that is inadequate for the rated voltage of the appliance, not exceeding 42 V		N/A
	In addition, the motors comply with the requirements of Annex I		N/A
24.7	Detachable hose-sets for connection of appliances to the water mains comply with IEC 61770		N/A
	They are supplied with the appliance		N/A
	Appliances intended to be permanently connected to the water mains not connected by a detachable hose-set		N/A
24.8	Motor running capacitors in appliances for which 30.2.3 is applicable and that are permanently connected in series with a motor winding, not causing a hazard in event of a failure		N/A
	One or more of the following conditions are to be met:		—
	- the capacitors are of class P2 according to IEC 60252-1		N/A
	- the capacitors are housed within a metallic or ceramic enclosure		N/A
	- the distance of separation of the outer surface to adjacent non-metallic parts exceeds 50 mm		N/A
	- adjacent non-metallic parts within 50 mm withstand the needle-flame test of Annex E		N/A
	- adjacent non-metallic parts within 50 mm classified as at least V-1 according to IEC 60695-11-10		N/A
25	<b>SUPPLY CONNECTION AND EXTERNAL FLEXIBLE CORDS</b>		<b>P</b>
25.1	Appliance not intended for permanent connection to fixed wiring, means for connection to the supply:		—
	- supply cord fitted with a plug,		N/A
	- an appliance inlet having at least the same degree of protection against moisture as required for the appliance, or		N/A

IEC 60335-2-29			
Clause	Requirement + Test	Result - Remark	Verdict
	- pins for insertion into socket-outlets	Direct plug-in device	P
25.2	Appliance not provided with more than one means of connection to the supply mains		P
	Stationary appliance for multiple supply may be provided with more than one means of connection, provided electric strength test of 1250 V for 1 min between each means of connection causes no breakdown		N/A
25.3	Appliance intended to be permanently connected to fixed wiring provided with one of the following means for connection to the supply mains:		—
	- a set of terminals allowing the connection of a flexible cord		N/A
	- a fitted supply cord		N/A
	- a set of supply leads accommodated in a suitable compartment		N/A
	- a set of terminals for the connection of cables of fixed wiring, cross-sectional areas specified in 26.6, and the appliance allows the connection of the supply conductors after the appliance has been fixed to its support		N/A
	- a set of terminals and cable entries, conduit entries, knock-outs or glands, allowing connection of appropriate types of cable or conduit, and the appliance allows the connection of the supply conductors after the appliance has been fixed to its support		N/A
	For a fixed appliance constructed so that parts can be removed to facilitate easy installation, this requirement is met if it is possible to connect the fixed wiring without difficulty after a part of the appliance has been fixed to its support		N/A
25.4	Cable and conduit entries, rated current of appliance not exceeding 16 A, dimension according to table 10 (mm) .....		N/A
	Introduction of conduit or cable does not reduce clearances or creepage distances below values specified in clause 29		N/A
25.5	Method for assembling the supply cord to the appliance:		—
	- type X attachment		N/A
	- type Y attachment		N/A

IEC 60335-2-29			
Clause	Requirement + Test	Result - Remark	Verdict
	- type Z attachment, if allowed in relevant part 2		N/A
	Type X attachment, other than those with a specially prepared cord, not used for flat twin tinsel cords		N/A
	For multi-phase appliances supplied with a supply cord and that are intended to be permanently connected to fixed wiring, the supply cord is assembled to the appliance by type Y attachment		N/A
25.6	Plugs fitted with only one flexible cord	Direct plug-in device	N/A
25.7	Supply cords, other than for class III appliances, being one of the following types:		—
	- rubber sheathed (at least 60245 IEC 53)		N/A
	- polychloroprene sheathed (at least 60245 IEC 57)		N/A
	- cross-linked polyvinyl chloride sheathed (at least 60245 IEC 88)		N/A
	- polyvinyl chloride sheathed. Not used if they are likely to touch metal parts having a temperature rise exceeding 75 K during the test of clause 11		—
	<ul style="list-style-type: none"> <li>light polyvinyl chloride sheathed cord (60227 IEC 52), for appliances not exceeding 3 kg</li> </ul>		N/A
	<ul style="list-style-type: none"> <li>ordinary polyvinyl chloride sheathed cord (60227 IEC 53), for other appliances</li> </ul>		N/A
	- heat resistant polyvinyl chloride sheathed. Not used for type X attachment other than specially prepared cords		—
	<ul style="list-style-type: none"> <li>heat-resistant light polyvinyl chloride sheathed cord (60227 IEC 56), for appliances not exceeding 3 kg</li> </ul>		N/A
	<ul style="list-style-type: none"> <li>heat-resistant polyvinyl chloride sheathed cord (60227 IEC 57), for other appliances</li> </ul>		N/A
	Supply cords for class III appliances adequately insulated		N/A
	Test with 500 V for 2 min for supply cords of class III appliances that contain live parts		N/A
	Battery chargers for charging automobile batteries shall not be fitted with natural rubber sheathed supply cords (IEC 60335-2-29).		N/A
25.8	Nominal cross-sectional area of supply cords not less than table 11; rated current (A); cross-sectional area (mm <sup>2</sup> ).....:		N/A

IEC 60335-2-29			
Clause	Requirement + Test	Result - Remark	Verdict
25.9	Supply cords not in contact with sharp points or edges		N/A
25.10	Supply cord of class I appliances have a green/yellow core for earthing		N/A
25.11	Conductors of supply cords not consolidated by soldering where they are subject to contact pressure, unless		N/A
	the contact pressure is provided by spring terminals		N/A
25.12	Insulation of the supply cord not damaged when moulding the cord to part of the enclosure		N/A
25.13	Inlet openings so constructed as to prevent damage to the supply cord		N/A
	If the enclosure at the inlet opening is not of insulating material, a non-detachable lining or bushing complying with 29.3 for supplementary insulation provided		N/A
	If unsheathed supply cord, a similar additional bushing or lining is required, unless the appliance is		N/A
	class 0, or		N/A
	a class III appliance not containing live parts		N/A
25.14	Supply cords moved while in operation adequately protected against excessive flexing		N/A
	Flexing test, as described:		—
	- applied force (N).....:		N/A
	- number of flexings.....:		N/A
	The test does not result in:		—
	- short-circuit between the conductors, such that the current exceeds a value of twice the rated current		N/A
	- breakage of more than 10% of the strands of any conductor		N/A
	- separation of the conductor from its terminal		N/A
	- loosening of any cord guard		N/A
	- damage to the cord or the cord guard		N/A
	- broken strands piercing the insulation and becoming accessible		N/A

IEC 60335-2-29			
Clause	Requirement + Test	Result - Remark	Verdict
25.15	For appliances with supply cord and appliances to be permanently connected to fixed wiring by a flexible cord, conductors of the supply cord relieved from strain, twisting and abrasion by use of cord anchorage		N/A
	The cord cannot be pushed into the appliance to such an extent that the cord or internal parts of the appliance can be damaged		N/A
	Pull and torque test of supply cord, values shown in table 12: mass (kg); pull (N); torque (not on automatic cord reel) (Nm).....:		N/A
	Cord not damaged and max. 2 mm displacement of the cord		N/A
25.16	Cord anchorages for type X attachments constructed and located so that:		—
	- replacement of the cord is easily possible		N/A
	- it is clear how the relief from strain and the prevention of twisting are obtained		N/A
	- they are suitable for different types of supply cord		N/A
	- cord cannot touch the clamping screws of cord anchorage if these screws are accessible, unless		N/A
	they are separated from accessible metal parts by supplementary insulation		N/A
	- the cord is not clamped by a metal screw which bears directly on the cord		N/A
	- at least one part of the cord anchorage securely fixed to the appliance, unless		N/A
	it is part of a specially prepared cord		N/A
	- screws which have to be operated when replacing the cord do not fix any other component, unless		N/A
	the appliance becomes inoperative or incomplete or the parts cannot be removed without a tool		N/A
	- if labyrinths can be bypassed the test of 25.15 is nevertheless withstood		N/A
	- for class 0, 0I and I appliances they are of insulating material or are provided with an insulating lining, unless		N/A
	failure of the insulation of the cord does not make accessible metal parts live		N/A

IEC 60335-2-29			
Clause	Requirement + Test	Result - Remark	Verdict
	- for class II appliances they are of insulating material, or		N/A
	if of metal, they are insulated from accessible metal parts by supplementary insulation		N/A
	After the test of 25.15, under the conditions specified, the conductors have not moved by more than 1 mm in the terminals		N/A
25.17	Adequate cord anchorages for type Y and Z attachment, test with the cord supplied with the appliance		N/A
25.18	Cord anchorages only accessible with the aid of a tool, or		N/A
	Constructed so that the cord can only be fitted with the aid of a tool		N/A
25.19	Type X attachment, glands not used as cord anchorage in portable appliances		N/A
	Tying the cord into a knot or tying the cord with string not used		N/A
25.20	The insulated conductors of the supply cord for type Y and Z attachment additionally insulated from accessible metal parts		N/A
25.21	Space for supply cord for type X attachment or for connection of fixed wiring constructed:		—
	- to permit checking of conductors with respect to correct positioning and connection before fitting any cover		N/A
	- so there is no risk of damage to the conductors or their insulation when fitting the cover		N/A
	- for portable appliances, so that the uninsulated end of a conductor, if it becomes free from the terminal, prevented from contact with accessible metal parts		N/A
	2 N test to the conductor for portable appliances; no contact with accessible metal parts		N/A
25.22	Appliance inlets:		—
	- live parts not accessible during insertion or removal		N/A
	Requirement not applicable to appliance inlets complying with IEC 60320-1		N/A

IEC 60335-2-29			
Clause	Requirement + Test	Result - Remark	Verdict
	- connector can be inserted without difficulty		N/A
	- the appliance is not supported by the connector		N/A
	- not for cold conditions if temp. rise of external metal parts exceeds 75 K during clause 11, unless		N/A
	the supply cord is unlikely to touch such metal parts		N/A
25.23	Interconnection cords comply with the requirements for the supply cord, except that:		N/A
	- the cross-sectional area of the conductors is determined on the basis of the maximum current during clause 11		N/A
	- the thickness of the insulation may be reduced		N/A
	If necessary, electric strength test of 16.3		N/A
25.24	Interconnection cords not detachable without the aid of a tool if compliance with this standard is impaired when they are disconnected		N/A
25.25	Dimensions of pins that are inserted into socket-outlets compatible with the dimensions of the relevant socket-outlet.	The plug tested according standard EN 50075 and BS1363	P
	Dimensions of pins and engagement face in accordance with the dimensions of the relevant plug in IEC/TR 60083		P
26	<b>TERMINALS FOR EXTERNAL CONDUCTORS</b>		N/A
26.1	Appliances provided with terminals or equally effective devices for connection of external conductors	No terminals for external conductors	N/A
	Terminals only accessible after removal of a non-detachable cover, except		N/A
	for class III appliances that do not contain live parts		N/A
	Earthing terminals may be accessible if a tool is required to make the connections and means are provided to clamp the wire independently from its connection		N/A
26.2	Appliances with type X attachment and appliances for the connection of cables to fixed wiring provided with terminals in which connections are made by means of screws, nuts or similar devices, unless		N/A
	the connections are soldered		N/A

IEC 60335-2-29			
Clause	Requirement + Test	Result - Remark	Verdict
	Screws and nuts not used to fix any other component, except		N/A
	internal conductors, if so arranged that they are unlikely to be displaced when fitting the supply conductors		N/A
	If soldered connections used, the conductor so positioned or fixed that reliance is not placed on soldering alone, unless		N/A
	barriers provided so that neither clearances nor creepage distances between live parts and other metal parts reduced below the values for supplementary insulation if the conductor becomes free at the soldered joint		N/A
26.3	Terminals for type X attachment and for connection of cables of fixed wiring so constructed that the conductor is clamped between metal surfaces with sufficient contact pressure but without damaging the conductor		N/A
	Terminals fixed so that when the clamping means is tightened or loosened:		—
	- the terminal does not become loose		N/A
	- internal wiring is not subjected to stress		N/A
	- neither clearances nor creepage distances are reduced below the values in clause 29		N/A
	Compliance checked by inspection and by the test of subclause 9.6 of IEC 60999-1, the torque applied being equal to two-thirds of the torque specified (Nm).....:		N/A
	No deep or sharp indentations of the conductors		N/A
26.4	Terminals for type X attachment, except those having a specially prepared cord and those for the connection of cables of fixed wiring, no special preparation of conductors such as by soldering, use of cable lugs, eyelets or similar, and		N/A
	so constructed or placed that conductors prevented from slipping out when clamping screws or nuts are tightened		N/A
26.5	Terminals for type X attachment so located or shielded that if a wire of a stranded conductor escapes, no risk of accidental connection to other parts that result in a hazard		N/A

IEC 60335-2-29			
Clause	Requirement + Test	Result - Remark	Verdict
	Stranded conductor test, 8 mm insulation removed		N/A
	No contact between live parts and accessible metal parts and,		N/A
	for class II constructions, between live parts and metal parts separated from accessible metal parts by supplementary insulation only		N/A
	This requirement does not apply to the terminals of the output circuit (IEC 60335-2-29).		N/A
26.6	Terminals for type X attachment and for connection of cables of fixed wiring suitable for connection of conductors with cross-sectional area according to table 13; rated current (A); nominal cross-sectional area (mm <sup>2</sup> ).....:		N/A
	If a specially prepared cord is used, terminals need only be suitable for that cord		N/A
26.7	Terminals for type X attachment, except in class III appliances not containing live parts, accessible after removal of a cover or part of the enclosure		N/A
26.8	Terminals for the connection of fixed wiring, including the earthing terminal, located close to each other		N/A
26.9	Terminals of the pillar type constructed and located as specified		N/A
26.10	Terminals with screw clamping and screwless terminals not used for flat twin tinsel cords, unless		N/A
	conductors ends fitted with means suitable for screw terminals		N/A
	Pull test of 5 N to the connection		N/A
26.11	For type Y and Z attachment, soldered, welded, crimped or similar connections may be used		N/A
	For Class II appliances, the conductor so positioned or fixed that reliance is not placed on soldering, welding or crimping alone		N/A
	If soldering, welding or crimping alone used, barriers provided so that clearances and creepage distances between live parts and other metal parts are not reduced below the values for supplementary insulation if the conductor becomes free		N/A
27	PROVISION FOR EARTHING		P

IEC 60335-2-29			
Clause	Requirement + Test	Result - Remark	Verdict
27.1	Accessible metal parts of Class 0I and I appliances permanently and reliably connected to an earthing terminal or earthing contact of the appliance inlet	Class II appliance	N/A
	Earthing terminals and earthing contacts not connected to the neutral terminal		N/A
	Class 0, II and III appliances have no provision for earthing	Class II appliance	P
	Safety extra-low voltage circuits not earthed, unless		N/A
	protective extra-low voltage circuits		N/A
27.2	Clamping means of earthing terminals adequately secured against accidental loosening		N/A
	Terminals for the connection of external equipotential bonding conductors allow connection of conductors of 2,5 to 6 mm <sup>2</sup> , and		N/A
	do not provide earthing continuity between different parts of the appliance, and		N/A
	conductors cannot be loosened without the aid of a tool		N/A
27.3	For a detachable part having an earth connection and being plugged into another part of the appliance, the earth connection is made before and separated after current-carrying connections when removing the part		N/A
	For appliances with supply cords, current-carrying conductors become taut before earthing conductor, if the cord slips out of the cord anchorage		N/A
27.4	No risk of corrosion resulting from contact between parts of the earthing terminal and the copper of the earthing conductor or other metal		N/A
	Parts providing earthing continuity, other than parts of a metal frame or enclosure, have adequate resistance to corrosion		N/A
	If of steel, these parts provided with an electroplated coating with a thickness at least 5 µm		N/A
	Adequate protection against rusting of parts of coated or uncoated steel, only intended to provide or transmit contact pressure		N/A
	In the body of the earthing terminal is a part of a frame or enclosure of aluminium or aluminium alloys, precautions taken to avoid risk of corrosion		N/A

<b>IEC 60335-2-29</b>			
Clause	Requirement + Test	Result - Remark	Verdict
27.5	Low resistance of connection between earthing terminal and earthed metal parts		N/A
	This requirement does not apply to connections providing earthing continuity in the protective extra-low voltage circuit, provided the clearances of basic insulation are based on the rated voltage of the appliance		N/A
	Resistance not exceeding 0,1 $\Omega$ at the specified low-resistance test ( $\Omega$ ) .....		N/A
27.6	The printed conductors of printed circuit boards not used to provide earthing continuity in hand-held appliances.		N/A
	They may be used to provide earthing continuity in other appliances if at least two tracks are used with independent soldering points and the appliance complies with 27.5 for each circuit		N/A
<b>28</b>	<b>SCREWS AND CONNECTIONS</b>		<b>N/A</b>
28.1	Fixings, electrical connections and connections providing earthing continuity withstand mechanical stresses	No such screws	N/A
	Screws not of soft metal liable to creep, such as zinc or aluminium		N/A
	Diameter of screws of insulating material min. 3 mm		N/A
	Screws of insulating material not used for any electrical connections or connections providing earthing continuity		N/A
	Screws used for electrical connections or connections providing earthing continuity screwed into metal		N/A
	Screws not of insulating material if their replacement by a metal screw can impair supplementary or reinforced insulation		N/A
	For type X attachment, screws to be removed for replacement of supply cord or for user maintenance, not of insulating material if their replacement by a metal screw impairs basic insulation		N/A
	For screws and nuts; torque-test as specified in table 14.....		N/A

IEC 60335-2-29			
Clause	Requirement + Test	Result - Remark	Verdict
28.2	Electrical connections and connections providing earthing continuity constructed so that contact pressure is not transmitted through non-ceramic insulating material liable to shrink or distort, unless		N/A
	there is resiliency in the metallic parts to compensate for shrinkage or distortion of the insulating material		N/A
	This requirement does not apply to electrical connections in circuits of appliances for which:		—
	<ul style="list-style-type: none"> <li>30.2.2 is applicable and that carry a current not exceeding 0,5 A</li> </ul>		N/A
	<ul style="list-style-type: none"> <li>30.2.3 is applicable and that carry a current not exceeding 0,2 A</li> </ul>		N/A
28.3	Space-threaded (sheet metal) screws only used for electrical connections if they clamp the parts together		N/A
	Thread-cutting (self-tapping) screws and thread rolling screws only used for electrical connections if they generate a full form standard machine screw thread		N/A
	Thread-cutting (self-tapping) screws not used if they are likely to be operated by the user or installer		N/A
	Thread-cutting, thread rolling and space threaded screws may be used in connections providing earthing continuity provided it is not necessary to disturb the connection:		—
	- in normal use,		N/A
	- during user maintenance,		N/A
	- when replacing a supply cord having a type X attachment, or		N/A
	- during installation		N/A
	At least two screws being used for each connection providing earthing continuity, unless		N/A
	the screw forms a thread having a length of at least half the diameter of the screw		N/A
28.4	Screws and nuts that make mechanical connection secured against loosening if they also make electrical connections or connections providing earthing continuity		N/A

IEC 60335-2-29			
Clause	Requirement + Test	Result - Remark	Verdict
	This requirement does not apply to screws in the earthing circuit if at least two screws are used, or		N/A
	if an alternative earthing circuit is provided		N/A
	Rivets for electrical connections or connections providing earthing continuity secured against loosening if the connections are subjected to torsion		N/A
29	<b>CLEARANCES, CREEPAGE DISTANCES AND SOLID INSULATION</b>		P
	Clearances, creepage distances and solid insulation withstand electrical stress		P
	For coatings used on printed circuits boards to protect the microenvironment (Type 1) or to provide basic insulation (Type 2), Annex J applies.....:		N/A
	The microenvironment is pollution degree 1 under type 1 protection		N/A
	For type 2 protection, the spacing between the conductors before the protection is applied is not less than the values specified in Table 1 of IEC 60664-3		N/A
	These values apply to functional, basic, supplementary and reinforced insulation .....		N/A
29.1	Clearances not less than the values specified in table 16, taking into account the rated impulse voltage for the overvoltage categories of table 15, unless .....	(see appended table)	P
	for basic insulation and functional insulation they comply with the impulse voltage test of clause 14		N/A
	However, if the distances are affected by wear, distortion, movement of the parts or during assembly, the clearances for rated impulse voltages of 1500V and above are increased by 0,5 mm and the impulse voltage test is not applicable		N/A
	Impulse voltage test is not applicable:		—
	- when the microenvironment is pollution degree 3, or		N/A
	- for basic insulation of class 0 and class 01 appliances		N/A
	Appliances are in overvoltage category II		P

<b>IEC 60335-2-29</b>			
Clause	Requirement + Test	Result - Remark	Verdict
	A force of 2 N is applied to bare conductors, other than heating elements		P
	A force of 30 N is applied to accessible surfaces		P
29.1.1	Clearances of basic insulation withstand the overvoltages, taking into account the rated impulse voltage		P
	The values of table 16 or the impulse voltage test of clause 14 are applicable.....:	(see appended table)	P
	Clearance at the terminals of tubular sheathed heating elements may be reduced to 1,0 mm if the microenvironment is pollution degree 1		N/A
	Lacquered conductors of windings considered to be bare conductors		P
29.1.2	Clearances of supplementary insulation not less than those specified for basic insulation in table 16 .....	(see appended table)	P
29.1.3	Clearances of reinforced insulation not less than those specified for basic insulation in table 16, using the next higher step for rated impulse voltage .....	(see appended table)	P
	For double insulation, with no intermediate conductive part between basic and supplementary insulation, clearances are measured between live parts and the accessible surface, and the insulation system is treated as reinforced insulation		P
29.1.4	Clearances for functional insulation are the largest values determined from:		—
	- table 16 based on the rated impulse voltage .....	(see appended table)	P
	- table F.7a in IEC 60664-1, frequency not exceeding 30 kHz		P
	- clause 4 of IEC 60664-4, frequency exceeding 30 kHz		N/A
	If values of table 16 are largest, the impulse voltage test of clause 14 may be applied instead, unless		N/A
	the microenvironment is pollution degree 3, or		N/A
	the distances can be affected by wear, distortion, movement of the parts or during assembly		N/A
	However, clearances are not specified if the appliance complies with clause 19 with the functional insulation short-circuited		N/A

IEC 60335-2-29			
Clause	Requirement + Test	Result - Remark	Verdict
	Lacquered conductors of windings considered to be bare conductors		P
	However, clearances at crossover points are not measured		P
	Clearance between surfaces of PTC heating elements may be reduced to 1mm		N/A
29.1.5	Appliances having higher working voltages than rated voltage, clearances for basic insulation are the largest values determined from:		—
	- table 16 based on the rated impulse voltage .....	The maximum working voltage is 246 Vrms / 536 Vpeak between primary winding and secondary winding of T1	P
	- table F.7a in IEC 60664-1, frequency not exceeding 30 kHz		P
	- clause 4 of IEC 60664-4, frequency exceeding 30 kHz		N/A
	If clearances for basic insulation are selected from Table F.7a of IEC 60664-1 or Clause 4 of IEC 60664-4, the clearances of supplementary insulation are not less than those specified for basic insulation		N/A
	If clearances for basic insulation are selected from Table F.7a of IEC 60664-1, the clearances of reinforced insulation dimensioned as specified in Table F.7a are to withstand 160% of the withstand voltage required for basic insulation		N/A
	If clearances for basic insulation are selected from Clause 4 of IEC 60664-4, the clearances of reinforced insulation are twice the value required for basic insulation		N/A
	If the secondary winding of a step-down transformer is earthed, or if there is an earthed screen between the primary and secondary windings, clearances of basic insulation on the secondary side not less than those specified in table 16, but using the next lower step for rated impulse voltage		N/A
	Circuits supplied with a voltage lower than rated voltage, clearances of functional insulation are based on the working voltage used as the rated voltage in table 15		N/A

<b>IEC 60335-2-29</b>			
Clause	Requirement + Test	Result - Remark	Verdict
29.2	Creepage distances not less than those appropriate for the working voltage, taking into account the material group and the pollution degree.....:	(see appended table)	P
	Pollution degree 2 applies, unless		P
	- precautions taken to protect the insulation; pollution degree 1		N/A
	- insulation subjected to conductive pollution; pollution degree 3		N/A
	A force of 2 N is applied to bare conductors, other than heating elements		P
	A force of 30 N is applied to accessible surfaces		P
	In a double insulation system, the working voltage for both the basic and supplementary insulation is taken as the working voltage across the complete double insulation system		N/A
29.2.1	Creepage distances of basic insulation not less than specified in table 17.....:	(see appended table)	P
	However, if the working voltage is periodic and has a frequency exceeding 30 kHz, the creepage distances are also determined from table 2 of IEC 60664-4, these values being used if exceeding the values in table 17 .....		N/A
	Except for pollution degree 1, corresponding creepage distance not less than the minimum specified for the clearance in table 16, if the clearance has been checked according to the test of clause 14 .....		N/A
29.2.2	Creepage distances of supplementary insulation at least those specified for basic insulation in table 17, or .....	(see appended table)	P
	Table 2 of IEC 60664-4, as applicable .....		N/A
29.2.3	Creepage distances of reinforced insulation at least double those specified for basic insulation in table 17, or .....	(see appended table)	P
	Table 2 of IEC 60664-4, as applicable .....		N/A
29.2.4	Creepage distances of functional insulation not less than specified in table 18.....:	(see appended table)	P

IEC 60335-2-29			
Clause	Requirement + Test	Result - Remark	Verdict
	However, if the working voltage is periodic and has a frequency exceeding 30 kHz, the creepage distances are also determined from table 2 of IEC 60664-4, these values being used if exceeding the values in table 18 .....		N/A
	Creepage distances may be reduced if the appliance complies with clause 19 with the functional insulation short-circuited		N/A
29.3	Supplementary and reinforced insulation have adequate thickness, or a sufficient number of layers, to withstand the electrical stresses		P
	Compliance checked:		—
	- by measurement, in accordance with 29.3.1, or		P
	- by an electric strength test in accordance with 29.3.2, or		P
	- by an assessment of the thermal quality of the material combined with an electric strength test, in accordance with 29.3.3, and		N/A
	for accessible parts of reinforced insulation consisting of a single layer, by measurement in accordance with 29.3.4, or		N/A
	- as specified in subclause 6.3 of IEC 60664-4 for insulation that is subjected to any periodic voltage having a frequency exceeding 30 kHz		N/A
29.3.1	Supplementary insulation have a thickness of at least 1 mm		N/A
	Reinforced insulation have a thickness of at least 2 mm	Enclosure: 2,5 mm	P
29.3.2	Each layer of material withstand the electric strength test of 16.3 for supplementary insulation		P
	Supplementary insulation consist of at least 2 layers		N/A
	Reinforced insulation consist of at least 3 layers	Triple insulated wire used as secondary winding Insulating tape around core: 3 layers	P
29.3.3	The insulation is subjected to the dry heat test Bb of IEC 60068-2-2, followed by		N/A
	the electric strength test of 16.3		N/A

IEC 60335-2-29			
Clause	Requirement + Test	Result - Remark	Verdict
	If the temperature rise during the tests of clause 19 does not exceed the value specified in table 3, the test of IEC 60068-2-2 is not carried out		N/A
29.3.4	Thickness of accessible parts of reinforced insulation consisting of a single layer not less than specified in table 19.....:		N/A
<b>30</b>	<b>RESISTANCE TO HEAT AND FIRE</b>		<b>P</b>
30.1	External parts of non-metallic material,		P
	parts supporting live parts, and		P
	parts of thermoplastic material providing supplementary or reinforced insulation		P
	sufficiently resistant to heat		P
	Ball-pressure test according to IEC 60695-10-2		P
	External parts tested at 40 °C plus the maximum temperature rise determined during the test of clause 11, or at 75 °C, whichever is the higher; temperature (°C).....:	125 °C for all enclosure materials (including AC plug pin holder material)	P
	Parts supporting live parts tested at 40°C plus the maximum temperature rise determined during the test of clause 11, or at 125 °C, whichever is the higher; temperature (°C).....:	125 °C for bobbin material and PCB	P
	Parts of thermoplastic material providing supplementary or reinforced insulation tested at 25 °C plus the maximum temperature rise determined during clause 19, if higher; temperature (°C) .....		N/A
30.2	Parts of non-metallic material resistant to ignition and spread of fire		P
	This requirement does not apply to:		—
	parts having a mass not exceeding 0,5 g, provided the cumulative effect is unlikely to propagate flames that originate inside the appliance by propagating flames from one part to another, or		P
	decorative trims, knobs and other parts unlikely to be ignited or to propagate flames that originate inside the appliance		P
	Compliance checked by the test of 30.2.1, and in addition:		P
	- for attended appliances, 30.2.2 applies		N/A

IEC 60335-2-29			
Clause	Requirement + Test	Result - Remark	Verdict
	- for unattended appliances, 30.2.3 applies		P
	For appliances for remote operation, 30.2.3 applies		N/A
	For base material of printed circuit boards, 30.2.4 applies		N/A
30.2.1	Parts of non-metallic material subjected to the glow-wire test of IEC 60695-2-11 at 550 °C	All enclosure materials tested at 750°C, no flame, refer to EN 50075 test. No flame	P
	However, test not carried out if the material is classified as having a glow-wire flammability index according to IEC 60695-2-12 of at least 550 °C, or		N/A
	the material is classified at least HB40 according to IEC 60695-11-10		N/A
	Parts for which the glow-wire test cannot be carried out need to meet the requirements in ISO 9772 for material classified HBF		N/A
30.2.2	Appliances operated while attended, parts of non-metallic material supporting current-carrying connections, and		N/A
	parts of non-metallic material within a distance of 3mm of such connections,		N/A
	subjected to the glow-wire test of IEC 60695-2-11		N/A
	The test severity is:		—
	- 750 °C, for connections carrying a current exceeding 0,5 A during normal operation		N/A
	- 650 °C, for other connections		N/A
	Glow-wire applied to an interposed shielding material, if relevant		N/A
	The glow-wire test is not carried out on parts of material classified as having a glow-wire flammability index according to IEC 60695-2-12 of at least:		—
	- 750 °C, for connections carrying a current exceeding 0,5 A during normal operation		N/A
	- 650 °C, for other connections		N/A
	The glow-wire test is also not carried out on small parts. These parts are to:		—
	- comprise material having a glow-wire flammability index of at least 750 °C, or 650 °C as appropriate, or		N/A

IEC 60335-2-29			
Clause	Requirement + Test	Result - Remark	Verdict
	- comply with the needle-flame test of Annex E, or		N/A
	- comprise material classified as V-0 or V-1 according to IEC 60695-11-10 .....		N/A
	Glow-wire test not applicable to conditions as specified .....		N/A
30.2.3	Appliances operated while unattended, tested as specified in 30.2.3.1 and 30.2.3.2		P
	The tests are not applicable to conditions as specified .....		N/A
30.2.3.1	Parts of non-metallic material supporting connections carrying a current exceeding 0,2 A during normal operation, and	850 °C for Bobbin and PCB, no flame	P
	parts of non-metallic material, other than small parts, within a distance of 3 mm,		P
	subjected to the glow-wire test of IEC 60695-2-11 with a test severity of 850 °C		N/A
	Glow-wire applied to an interposed shielding material, if relevant		N/A
	The glow-wire test is not carried out on parts of material classified as having a glow-wire flammability index according to IEC 60695-2-12 of at least 850 °C		N/A
30.2.3.2	Parts of non-metallic material supporting connections, and	850 °C for Bobbin and PCB No flame	P
	parts of non-metallic material within a distance of 3mm,		P
	subjected to glow-wire test of IEC 60695-2-11		P
	The test severity is:		—
	- 750 °C, for connections carrying a current exceeding 0,2 A during normal operation	Pin sleeving (according EN 50075)	P
	- 650 °C, for other connections	Enclosure	P
	Glow-wire applied to an interposed shielding material, if relevant		N/A
	However, the glow-wire test of 750 °C or 650 °C as appropriate, is not carried out on parts of material fulfilling both or either of the following classifications:		—
	- a glow-wire ignition temperature according to IEC 60695-2-13 of at least:		N/A

IEC 60335-2-29			
Clause	Requirement + Test	Result - Remark	Verdict
	<ul style="list-style-type: none"> <li>775 °C, for connections carrying a current exceeding 0,2 A during normal operation</li> </ul>		N/A
	<ul style="list-style-type: none"> <li>675 °C, for other connections</li> </ul>		N/A
	- a glow-wire flammability index according to IEC 60695-2-12 of at least:		N/A
	- 750 °C, for connections carrying a current exceeding 0,2 A during normal operation		N/A
	- 650 °C, for other connections		N/A
	The glow-wire test is also not carried out on small parts. These parts are to:		—
	- comprise material having a glow-wire ignition temperature of at least 775 °C or 675 °C as appropriate, or		N/A
	- comprise material having a glow-wire flammability index of at least 750 °C or 650 °C as appropriate, or		N/A
	- comply with the needle-flame test of Annex E, or		N/A
	- comprise material classified as V-0 or V-1 according to IEC 60695-11-10		N/A
	The consequential needle-flame test of Annex E applied to non-metallic parts that encroach within the vertical cylinder placed above the centre of the connection zone and on top of the non-metallic parts supporting current-carrying connections, and parts of non-metallic material within a distance of 3 mm of such connections if these parts are those:		—
	- parts that withstood the glow-wire test of IEC 60695-2-11 of 750 °C or 650 °C as appropriate, but produce a flame that persist longer than 2 s, or	No flame	N/A
	- parts that comprised material having a glow-wire flammability index of at least 750 °C or 650 °C as appropriate, or		N/A
	- small parts, that comprised material having a glow-wire flammability index of at least 750 °C or 650 °C as appropriate, or		N/A
	- small parts for which the needle-flame test of Annex E was applied, or		N/A
	- small parts for which a material classification of V-0 or V-1 was applied		N/A
	However, the consequential needle-flame test is not carried out on non-metallic parts, including small parts, within the cylinder that are:		—

IEC 60335-2-29			
Clause	Requirement + Test	Result - Remark	Verdict
	- parts having a glow-wire ignition temperature of at least 775 °C or 675 °C as appropriate, or		N/A
	- parts comprising material classified as V-0 or V-1 according to IEC 60695-11-10, or		N/A
	- parts shielded by a flame barrier that meets the needle-flame test of Annex E or that comprises material classified as V-0 or V-1 according to IEC 60695-11-10		N/A
30.2.4	Base material of printed circuit boards subjected to the needle-flame test of Annex E		P
	Test not applicable to conditions as specified.....:	V-0 was used	P
31	<b>RESISTANCE TO RUSTING</b>		N/A
	Relevant ferrous parts adequately protected against rusting		N/A
	Tests specified in part 2 when necessary		N/A
32	<b>RADIATION, TOXICITY AND SIMILAR HAZARDS</b>		N/A
	Appliance does not emit harmful radiation or present a toxic or similar hazard due to their operation in normal use		N/A
	Compliance is checked by the limits or tests specified in part 2, if relevant		N/A
A	<b>ANNEX A (INFORMATIVE) ROUTINE TESTS</b>		N/A
	Description of routine tests to be carried out by the manufacturer		N/A
A.2	<b>Electric strength test</b>		N/A
	An electric strength test is carried out between the input and output circuits, the test voltage being:		—
	- 2 000 V, for battery chargers having a rated voltage not exceeding 150 V;		N/A
	- 2 500 V, for other battery chargers.		N/A
B	<b>ANNEX B (NORMATIVE) APPLIANCES POWERED BY RECHARGEABLE BATTERIES</b>		N/A
	The following modifications to this standard are applicable for appliances powered by batteries that are recharged in the appliance		N/A
	This annex does not apply to battery chargers		N/A

IEC 60335-2-29			
Clause	Requirement + Test	Result - Remark	Verdict
3.1.9	Appliance operated under the following conditions:		—
	- the appliance, supplied by its fully charged battery, operated as specified in relevant part 2		N/A
	- the battery is charged, the battery being initially discharged to such an extent that the appliance cannot operate		N/A
	-if possible, the appliance is supplied from the supply mains through its battery charger, the battery being initially discharged to such an extent that the appliance cannot operate. The appliance is operated as specified in relevant part 2		N/A
	- if the appliance incorporates inductive coupling between two parts that are detachable from each other, the appliance is supplied from the supply mains with the detachable part removed		N/A
3.6.2	Part to be removed in order to discard the battery is not considered to be detachable		N/A
5.B.101	Appliances supplied from the supply mains tested as specified for motor-operated appliances		N/A
7.1	Battery compartment for batteries intended to be replaced by the user, marked with battery voltage and polarity of the terminals		N/A
	The positive terminal indicated by symbol IEC 60417-5005 and the negative terminal by symbol IEC 60417-5006		N/A
7.6	Symbols 60417-5005 and IEC 60417-5006		N/A
7.12	The instructions give information regarding charging		N/A
	The instructions for appliances incorporating batteries intended to be replaced by the user includes required information		N/A
	Details about how to remove batteries containing materials hazardous to the environment given		N/A
7.15	Markings placed on the part of the appliance connected to the supply mains		N/A
8.2	Appliances having batteries that according to the instruction may be replaced by the user need only have basic insulation between live parts and the inner surface of the battery compartment		N/A

IEC 60335-2-29			
Clause	Requirement + Test	Result - Remark	Verdict
	If the appliance can be operated without batteries, double or reinforced insulation required		N/A
11.7	The battery is charged for the period stated in the instructions or 24 h .....		N/A
19.1	Appliances subjected to tests of 19.B.101, 19.B.102 and 19.B.103		N/A
19.10	Not applicable		N/A
19.B.101	Appliances supplied at rated voltage for 168 h, the battery being continually charged		N/A
19.B.102	For appliances having batteries that can be removed without the aid of a tool, short-circuit of the terminals of the battery, the battery being fully charged,		N/A
19.B.103	Appliances having batteries replaceable by the user supplied at rated voltage under normal operation with the battery removed or in any position allowed by the construction		N/A
21.B.101	Appliances having pins for insertion into socket-outlets have adequate mechanical strength		N/A
	Part of the appliance incorporating the pins subjected to the free fall test, procedure 2, of IEC 60068-2-31, the number of falls being:		—
	- 100, if the mass of the part does not exceed 250 g (g) .....		N/A
	- 50, if the mass of the part exceeds 250 g .....		N/A
	After the test, the requirements of 8.1, 15.1.1, 16.3 and clause 29 are met		N/A
22.3	Appliances having pins for insertion into socket-outlets tested as fully assembled as possible		N/A
25.13	An additional lining or bushing not required for interconnection cords in class III appliances or class III constructions operating at safety extra-low voltage not containing live parts		N/A
30.2	For parts of the appliance connected to the supply mains during the charging period, 30.2.3 applies		N/A
	For other parts, 30.2.2 applies		N/A
C	ANNEX C (NORMATIVE) AGEING TEST ON MOTORS		N/A

IEC 60335-2-29			
Clause	Requirement + Test	Result - Remark	Verdict
	Tests, as described, carried out when doubt with regard to the temperature classification of the insulation of a motor winding		N/A
	Test conditions as specified		N/A
D	ANNEX D (NORMATIVE) THERMAL MOTOR PROTECTORS		N/A
	Applicable to appliances having motors that incorporate thermal motor protectors necessary for compliance with the standard		N/A
	Test conditions as specified		N/A
E	ANNEX E (NORMATIVE) NEEDLE-FLAME TEST		N/A
	Needle-flame test carried out in accordance with IEC 60695-11-5, with the following modifications:		—
7	Severities		N/A
	The duration of application of the test flame is 30 s ± 1 s		N/A
9	Test procedure		—
9.1	The specimen so arranged that the flame can be applied to a vertical or horizontal edge as shown in the examples of Figure 1		N/A
9.2	The first paragraph does not apply		N/A
	If possible, the flame is applied at least 10 mm from a corner		N/A
9.3	The test is carried out on one specimen		N/A
	If the specimen does not withstand the test, the test may be repeated on two additional specimens, both withstanding the test		N/A
11	Evaluation of test results		—
	The duration of burning not exceeding 30 s		N/A
	However, for printed circuit boards, the duration of burning not exceeding 15 s		N/A
F	ANNEX F (NORMATIVE) CAPACITORS		
	Capacitors likely to be permanently subjected to the supply voltage, and used for radio interference suppression or voltage dividing, comply with the following clauses of IEC 60384-14, with the following modifications:		N/A

IEC 60335-2-29			
Clause	Requirement + Test	Result - Remark	Verdict
1.5	Terms and definitions		—
1.5.3	Class X capacitors tested according to subclass X2		N/A
1.5.4	This subclause is applicable		N/A
1.6	Marking		N/A
	Items a) and b) are applicable		N/A
3.4	Approval testing		N/A
3.4.3.2	Table 3 is applicable as described		N/A
4.1	Visual examination and check of dimensions		N/A
	This subclause is applicable		N/A
4.2	Electrical tests		N/A
4.2.1	This subclause is applicable		N/A
4.2.5	This subclause is applicable		N/A
4.2.5.2	Only table 11 is applicable		N/A
	Values for test A apply		N/A
	However, for capacitors in heating appliances the values for test B or C apply		N/A
4.12	Damp heat, steady state		N/A
	This subclause is applicable		N/A
	Only insulation resistance and voltage proof are checked		N/A
4.13	Impulse voltage		N/A
	This subclause is applicable		N/A
4.14	Endurance		N/A
	Subclauses 4.14.1, 4.14.3, 4.14.4 and 4.14.7 are applicable		N/A
4.14.7	Only insulation resistance and voltage proof are checked		N/A
	No visible damage		N/A
4.17	Passive flammability test		N/A
	This subclause is applicable		N/A
4.18	Active flammability test		N/A
	This subclause is applicable		N/A

IEC 60335-2-29			
Clause	Requirement + Test	Result - Remark	Verdict
G	ANNEX G (NORMATIVE) SAFETY ISOLATING TRANSFORMERS		P
	The following modifications to this standard are applicable for safety isolating transformers:		—
7	Marking and instructions		P
7.1	Transformers for specific use marked with:		P
	-name, trademark or identification mark of the manufacturer or responsible vendor .....		P
	-model or type reference .....		P
17	Overload protection of transformers and associated circuits		P
	Fail-safe transformers comply with subclause 15.5 of IEC 61558-1		N/A
22	Construction		P
	Subclauses 19.1 and 19.1.2 of IEC 61558-2-6 are applicable		P
29	Clearances, creepage distances and solid insulation		P
29.1, 29.2, 29.3	The distances specified in items 2a, 2c and 3 in table 13 of IEC 61558-1 apply	Pri. parts and Sec. parts Cl: 5,04 mm > 4,6 mm Cr: 5,04 mm > 5,0 mm Working voltage: 246 Vrms max. T1 core treated as pri. parts	P
	For insulated winding wires complying with subclause 19.12.3 of IEC 61558-1 there are no requirements for clearances or creepage distances		P
	For windings providing reinforced insulation, the distance specified in item 2c of table 13 of IEC 61558-1 is not assessed		N/A
	For safety isolating transformers subjected to periodic voltages with a frequency exceeding 30 kHz, the clearances, creepage distances and solid insulation values specified in IEC 60664-4 are applicable, if greater than the values specified in items 2a, 2c and 3 in table 13 of IEC 61558-1		N/A
H	ANNEX H (NORMATIVE) SWITCHES		N/A
	Switches comply with the following clauses of IEC 61058-1, as modified below:		—

IEC 60335-2-29			
Clause	Requirement + Test	Result - Remark	Verdict
	The tests of IEC 61058-1 carried out under the conditions occurring in the appliance		N/A
	Before being tested, switches are operated 20 times without load		N/A
8	Marking and documentation		N/A
	Switches are not required to be marked		N/A
	However, a switch that can be tested separately from the appliance marked with the manufacturer's name or trade mark and the type reference		N/A
13	Mechanism		N/A
	The tests may be carried out on a separate sample		N/A
15	Insulation resistance and dielectric strength		N/A
15.1	Not applicable		N/A
15.2	Not applicable		N/A
15.3	Applicable for full disconnection and micro-disconnection		N/A
17	Endurance		N/A
	Compliance is checked on three separate appliances or switches		N/A
	For 17.2.4.4, the number of cycles declared according to 7.1.4 is 10 000, unless		N/A
	otherwise specified in 24.1.3 of the relevant part 2 of IEC 60335 .....		N/A
	Switches for operation under no load and which can be operated only by a tool, and		N/A
	switches operated by hand that are interlocked so that they cannot be operated under load,		N/A
	are not subjected to the tests		N/A
	However, switches without this interlock are subjected to the test of 17.2.4.4 for 100 cycles of operation		N/A
	Subclauses 17.2.2 and 17.2.5.2 not applicable		N/A
	The ambient temperature during the test is that occurring in the appliance during the test of Clause 11 in IEC 60335-1		N/A

IEC 60335-2-29			
Clause	Requirement + Test	Result - Remark	Verdict
	The temperature rise of the terminals not more than 30 K above the temperature rise measured in clause 11 of IEC 60335-1 (K) .....		N/A
20	Clearances, creepage distances, solid insulation and coatings of rigid printed board assemblies		N/A
	This clause is applicable to clearances and creepage distances for functional insulation, across full disconnection and micro-disconnection, as stated in table 24		N/A
I	ANNEX I (NORMATIVE) MOTORS HAVING BASIC INSULATION THAT IS INADEQUATE FOR THE RATED VOLTAGE OF THE APPLIANCE		N/A
	The following modifications to this standard are applicable for motors having basic insulation that is inadequate for the rated voltage of the appliance:		N/A
8	Protection against access to live parts		N/A
8.1	Metal parts of the motor are considered to be bare live parts		N/A
11	Heating		N/A
11.3	The temperature rise of the body of the motor is determined instead of the temperature rise of the windings		N/A
11.8	The temperature rise of the body of the motor, where in contact with insulating material, not exceeding values in table 3 for the relevant insulating material		N/A
16	Leakage current and electric strength		N/A
16.3	Insulation between live parts of the motor and its other metal parts is not subjected to the test		N/A
19	Abnormal operation		N/A
19.1	The tests of 19.7 to 19.9 are not carried out		N/A
19.1.101	Appliance operated at rated voltage with each of the following fault conditions:		—
	- short circuit of the terminals of the motor, including any capacitor incorporated in the motor circuit		N/A
	- short circuit of each diode of the rectifier		N/A
	- open circuit of the supply to the motor		N/A
	- open circuit of any parallel resistor, the motor being in operation		N/A

IEC 60335-2-29			
Clause	Requirement + Test	Result - Remark	Verdict
	Only one fault simulated at a time, the tests carried out consecutively		N/A
22	Construction		N/A
22.1.101	For class I appliances incorporating a motor supplied by a rectifier circuit, the d.c. circuit being insulated from accessible parts of the appliance by double or reinforced insulation		N/A
	Compliance checked by the tests specified for double and reinforced insulation		N/A
J	ANNEX J (NORMATIVE) COATED PRINTED CIRCUIT BOARDS		N/A
	Testing of protective coatings of printed circuit boards carried out in accordance with IEC 60664-3 with the following modifications:		—
5.7	Conditioning of the test specimens		N/A
	When production samples are used, three samples of the printed circuit board are tested		N/A
5.7.1	Cold		N/A
	The test is carried out at -25 °C		N/A
5.7.3	Rapid change of temperature		N/A
	Severity 1 is specified		N/A
5.9	Additional tests		N/A
	This subclause is not applicable		N/A
K	ANNEX K (NORMATIVE) OVERVOLTAGE CATEGORIES		P
	The information on overvoltage categories is extracted from IEC 60664-1		P
	Overvoltage category is a numeral defining a transient overvoltage condition		P
	Equipment of overvoltage category IV is for use at the origin of the installation		N/A
	Equipment of overvoltage category III is equipment in fixed installations and for cases where the reliability and the availability of the equipment is subject to special requirements		N/A
	Equipment of overvoltage category II is energy consuming equipment to be supplied from the fixed installation		P

IEC 60335-2-29			
Clause	Requirement + Test	Result - Remark	Verdict
	If such equipment is subjected to special requirements with regard to reliability and availability, overvoltage category III applies		N/A
	Equipment of overvoltage category I is equipment for connection to circuits in which measures are taken to limit transient overvoltages to an appropriate low level		N/A
L	ANNEX L (INFORMATIVE) GUIDANCE FOR THE MEASUREMENT OF CLEARANCES AND CREEPAGE DISTANCES		P
	Information for the determination of clearances and creepage distances		P
M	ANNEX M (NORMATIVE) POLLUTION DEGREE		P
	The information on pollution degrees is extracted from IEC 60664-1		P
	Pollution		P
	The microenvironment determines the effect of pollution on the insulation, taking into account the macroenvironment		P
	Means may be provided to reduce pollution at the insulation by effective enclosures or similar		P
	Minimum clearances specified where pollution may be present in the microenvironment		P
	Degrees of pollution in the microenvironment		P
	For evaluating creepage distances, the following degrees of pollution in the microenvironment are established:		P
	- pollution degree 1: no pollution or only dry, non-conductive pollution occurs. The pollution has no influence		N/A
	- pollution degree 2: only non-conductive pollution occurs, except that occasionally a temporary conductivity caused by condensation is to be expected		P
	- pollution degree 3: conductive pollution occurs or dry non-conductive pollution occurs that becomes conductive due to condensation that is to be expected		N/A

IEC 60335-2-29			
Clause	Requirement + Test	Result - Remark	Verdict
	- pollution degree 4: the pollution generates persistent conductivity caused by conductive dust or by rain or snow		N/A
N	ANNEX N (NORMATIVE) PROOF TRACKING TEST		N/A
	The proof tracking test is carried out in accordance with IEC 60112 with the following modifications:		N/A
7	Test apparatus		N/A
7.3	Test solutions		N/A
	Test solution A is used		N/A
10	Determination of proof tracking index (PTI)		N/A
10.1	Procedure		N/A
	The proof voltage is 100V, 175V, 400V or 600V ...:		N/A
	The test is carried out on five specimens		N/A
	In case of doubt, additional test with proof voltage reduced by 25 V, the number of drops increased to 100		N/A
10.2	Report		N/A
	The report states if the PTI value was based on a test using 100 drops with a test voltage of (PTI-25) V		N/A
O	ANNEX O (INFORMATIVE) SELECTION AND SEQUENCE OF THE TESTS OF CLAUSE 30		P
	Description of tests for determination of resistance to heat and fire		P
P	ANNEX P (INFORMATIVE) GUIDANCE FOR THE APPLICATION OF THIS STANDARD TO APPLIANCES USED IN WARM DAMP EQUABLE CLIMATES		N/A
	Modifications applicable for class 0 and 01 appliances having a rated voltage exceeding 150V, intended to be used in countries having a warm damp equable climate and that are marked WDaE		N/A
	Modifications may also be applied to class 1 appliances having a rated voltage exceeding 150V, intended to be used in countries having a warm damp equable climate and that are marked WdaE, if liable to be connected to a supply mains that excludes the protective earthing conductor		N/A
5.7	The ambient temperature for the tests of clauses 11 and 13 is 40 +3/0 °C		N/A

IEC 60335-2-29			
Clause	Requirement + Test	Result - Remark	Verdict
7.1	The appliance marked with the letters WDaE		N/A
7.12	The instructions state that the appliance is to be supplied through a residual current device (RCD) having a rated residual operating current not exceeding 30 mA		N/A
	The instructions state that the appliance is considered to be suitable for use in countries having a warm damp equable climate, but may also be used in other countries		N/A
11.8	The values of Table 3 are reduced by 15 K		N/A
13.2	The leakage current for class I appliances not exceeding 0,5 mA		N/A
15.3	The value of t is 37 °C		N/A
16.2	The leakage current for class I appliances not exceeding 0,5 mA (mA):		N/A
19.13	The leakage current test of 16.2 is applied in addition to the electric strength test of 16.3		N/A
Q	ANNEX Q (INFORMATIVE) SEQUENCE OF TESTS FOR THE EVALUATION OF ELECTRONIC CIRCUITS		P
	Description of tests for appliances incorporating electronic circuits		P
R	ANNEX R (NORMATIVE) SOFTWARE EVALUATION		N/A
	Programmable electronic circuits requiring software incorporating measures to control the fault/error conditions specified in table R.1 or R.2 validated in accordance with the requirements of this annex		N/A
R.1	Programmable electronic circuits using software		N/A
	Programmable electronic circuits requiring software incorporating measures to control the fault/error conditions specified in table R.1 or R.2 constructed so that the software does not impair compliance with the requirements of this standard		N/A
R.2	Requirements for the architecture		N/A
	Programmable electronic circuits requiring software incorporating measures to control the fault/error conditions specified in table R.1 or R.2 use measures to control and avoid software-related faults/errors in safety-related data and safety-related segments of the software		N/A

IEC 60335-2-29			
Clause	Requirement + Test	Result - Remark	Verdict
R.2.1.1	Programmable electronic circuits requiring software incorporating measures to control the fault/error conditions specified in table R.2 have one of the following structures:		N/A
	- single channel with periodic self-test and monitoring		N/A
	- dual channel (homogenous) with comparison		N/A
	- dual channel (diverse) with comparison		N/A
	Programmable electronic circuits requiring software incorporating measures to control the fault/error conditions specified in table R.1 have one of the following structures:		N/A
	- single channel with functional test		N/A
	- single channel with periodic self-test		N/A
	- dual channel without comparison		N/A
R.2.2	Measures to control faults/errors		N/A
R.2.2.1	When redundant memory with comparison is provided on two areas of the same component, the data in one area is stored in a different format from that in the other area		N/A
R.2.2.2	Programmable electronic circuits with functions requiring software incorporating measures to control the fault/error conditions specified in table R.2 and that use dual channel structures with comparison, have additional fault/error detection means for any fault/errors not detected by the comparison		N/A
R.2.2.3	For programmable electronic circuits with functions requiring software incorporating measures to control the fault/error conditions specified in table R.1 or R.2, means are provided for the recognition and control of errors in transmissions to external safety-related data paths		N/A
R.2.2.4	For programmable electronic circuits with functions requiring software incorporating measures to control the fault/error conditions specified in table R.1 or R.2, the programmable electronic circuits incorporate measures to address the fault/errors in safety-related segments and data indicated in table R.1 and R.2 as appropriate		N/A

IEC 60335-2-29			
Clause	Requirement + Test	Result - Remark	Verdict
R.2.2.5	For programmable electronic circuits with functions requiring software incorporating measures to control the fault/error conditions specified in table R.1 or R.2, detection of a fault/error occur before compliance with clause 19 is impaired		N/A
R.2.2.6	The software is referenced to relevant parts of the operating sequence and the associated hardware functions		N/A
R.2.2.7	Labels used for memory locations are unique		N/A
R.2.2.8	The software is protected from user alteration of safety-related segments and data		N/A
R.2.2.9	Software and safety-related hardware under its control is initialized and terminates before compliance with clause 19 is impaired		N/A
R.3	Measures to avoid errors		N/A
R.3.1	General		N/A
	For programmable electronic circuits with functions requiring software incorporating measures to control the fault/error conditions specified in table R.1 or R.2, the following measures to avoid systematic fault in the software are applied		N/A
	Software that incorporates measures used to control the fault/error conditions specified in table R.2 is inherently acceptable for software required to control the fault/error conditions specified in table R.1		N/A
R.3.2	Specification		N/A
R.3.2.1	Software safety requirements:		N/A
	The specification of the software safety requirements includes the descriptions listed		N/A
R.3.2.2	Software architecture		N/A

IEC 60335-2-29			
Clause	Requirement + Test	Result - Remark	Verdict
R.3.2.2.1	The specification of the software architecture includes the aspects listed - techniques and measures to control software faults/errors (refer to R.2.2); - interactions between hardware and software; - partitioning into modules and their allocation to the specified safety functions; - hierarchy and call structure of the modules (control flow); - interrupt handling; - data flow and restrictions on data access; - architecture and storage of data; - time-based dependencies of sequences and data		N/A
R.3.2.2.2	The architecture specification is validated against the specification of the software safety requirements by static analysis		N/A
R.3.2.3	Module design and coding		N/A
R.3.2.3.1	Based on the architecture design, software is suitably refined into modules		N/A
	Software module design and coding is implemented in a way that is traceable to the software architecture and requirements		N/A
R.3.2.3.2	Software code is structured		N/A
R.3.2.3.3	Coded software is validated against the module specification by static analysis		N/A
	The module specification is validated against the architecture specification by static analysis		N/A
R.3.3.3	Software validation		N/A
	The software is validated with reference to the requirements of the software safety requirements specification		N/A
	Compliance is checked by simulation of:		N/A
	- input signals present during normal operation		N/A
	- anticipated occurrences		N/A
	- undesired conditions requiring system action		N/A

IEC 60335-2-29			
Clause	Requirement + Test	Result - Remark	Verdict
AA	ANNEX AA (NORMATIVE) BATTERY CHARGERS FOR USE BY CHILDREN (IEC 60335-2-29/A1)		N/A
	Battery chargers intended to be used by children at least eight years old without supervision shall comply with this standard but as modified by this annex. The battery charger have a d.c. output at SELV not exceeding 30 V and a rated output not exceeding 50 VA		N/A
5	GENERAL CONDITIONS FOR THE TESTS		N/A
5.201	When batteries are used, the generally available rechargeable batteries giving the most unfavourable conditions are used		N/A
6.1	Battery chargers suitable for outdoor use shall be class III		N/A
	Other battery chargers shall be class II or class III		N/A
6	CLASSIFICATION		N/A
6.2	Battery chargers suitable for outdoor use shall be at least IPX7		N/A
6.201	Enclosures shall be classified at least IP3X with regard to protection against ingress of solid foreign objects.		N/A
7	MARKING AND INSTRUCTIONS		N/A
7.1	Symbol 5957 of IEC 60417 or text "For indoor use only" for battery chargers for indoor use		N/A
	IP number		N/A
	Smiling face symbol together with 8+		N/A
7.6	Correct symbols used		N/A
7.12	Instructions for safe use contains:		N/A
	- Warning to only allow children at least 8 years old to use battery charger		N/A
	- Sufficient instructions for safe use of battery charger by a child		N/A
	- Explanation that battery charger is not a toy		N/A
	- Instruction for child not to try and recharge non-rechargeable batteries		N/A
	- Warning to examine battery charger regularly for damage		N/A

IEC 60335-2-29			
Clause	Requirement + Test	Result - Remark	Verdict
	- Warning in case battery charger is damaged		N/A
	Instruction for Class III battery charger to be supplied from transformer for toys		N/A
7.14	Height of symbol marked on the appliance at least 10 mm		N/A
	Height of lettering at least 3 mm		N/A
8	<b>PROTECTION AGAINST ACCESS TO LIVE PARTS</b>		N/A
8.1.1	Use of test probe B of IEC 61032: no contact with live parts or metal parts separated from live parts by basic insulation only, even after use of a tool to remove parts of enclosure		N/A
10	<b>POWER INPUT AND CURRENT</b>		N/A
10.101	The output voltage not exceed 42,4 V peak		N/A
11	<b>HEATING</b>		N/A
11.8	Temperature rises of parts that can be touched by test probe 18 of IEC 61032	(see appended table)	N/A
	- 25 K, if of metal;		N/A
	- 35 K, if of other material.		N/A
17	<b>OVERLOAD PROTECTION OF TRANSFORMERS AND ASSOCIATED CIRCUITS</b>		N/A
	Temperature rises of parts that can be touched by test probe 18 of IEC 61032	(see appended table)	N/A
	- 45 K, if of metal;		N/A
	- 55 K, if of other material.		N/A
19	<b>ABNORMAL OPERATION</b>		N/A
19.13	Temperature rises of parts that can be touched by test probe 18 of IEC 61032	(see appended table)	N/A
	- 45 K, if of metal;		N/A
	- 55 K, if of other material.		N/A
21	<b>MECHANICAL STRENGTH</b>		N/A
21.201	Impact test Eha of IEC 60068-2-75, with impact energy of 2 J		N/A
	For rectangular shaped battery chargers, the four sides and four edges are subjected to an impact. For other battery chargers, the enclosure is subjected to eight impacts equally spaced over the periphery.		N/A

IEC 60335-2-29			
Clause	Requirement + Test	Result - Remark	Verdict
	Free fall test Ed, Procedure 1 of IEC 60068-2-32, from the height of 500 mm		N/A
	Battery charger not damaged to such extent that compliance is impaired, live parts shall not become accessible		N/A
22	<b>CONSTRUCTION</b>		N/A
22.201	Battery charger with only one rated voltage or rated voltage range		N/A
	Battery charger not incorporate means for manually adjusting output voltage		N/A
22.202	Battery chargers shall be constructed so that reverse charging is prevented, regardless of the state of charge of the battery. This applies even if the battery is inserted with the wrong polarity.		N/A
24	<b>COMPONENTS</b>		N/A
24.201	Transformer for toys tested in accordance with sub-clauses 7.2, 20.5.1 and 20.101 and clause 15 of standard IEC 61558-2-7		N/A
25	<b>SUPPLY CONNECTION AND EXTERNAL FLEXIBLE CORDS</b>		N/A
25.1	Battery charger not provided with an appliance inlet		N/A
25.5	Battery charger provided with type Y or type Z attachment		N/A

IEC 60335-2-29			
Clause	Requirement + Test	Result - Remark	Verdict

10.2	TABLE: Current deviation					P
Current deviation of/at:	I rated (A)	I measured (A)	dI	Required dI	Remark	
LY045-022-1200E	0,2 A.	0,069	< +20%	+20%	100 V, 50 Hz	
		0,071	< +20%		100 V, 60 Hz	
		0,046	< +20%		240 V, 50 Hz	
		0,047	< +20%		240 V, 60 Hz	
LY045-045-1000E	0,2 A.	0,105	< +20%	+20%	100 V, 50 Hz	
		0,103	< +20%		100 V, 60 Hz	
		0,063	< +20%		240 V, 50 Hz	
		0,064	< +20%		240 V, 60 Hz	
LY045-068-0600E	0,2 A.	0,093	< +20%	+20%	100 V, 50 Hz	
		0,091	< +20%		100 V, 60 Hz	
		0,058	< +20%		240 V, 50 Hz	
		0,056	< +20%		240 V, 60 Hz	

10.102	TABLE: Output current deviation						P
Current deviation of/at:	U <sub>o</sub> rated (V)	I <sub>o</sub> rated (A)	I <sub>o</sub> measured (A)	d I <sub>o</sub>	Required d I <sub>o</sub>	Remark	
LY045-022-1200E	2,2	1,2	1,13	-5,8%	±10%	100 V, 60 Hz	
			1,20	0,0%	±10%	240 V, 50 Hz	
LY045-045-1000E	4,5	1,0	0,95	-5,0%	±10%	100 V, 60 Hz	
			1,03	+3,0%	±10%	240 V, 50 Hz	
LY045-068-0600E	6,8	0,6	0,54	-10,0%	±10%	100 V, 60 Hz	
			0,58	-3,3%	±10%	240 V, 50 Hz	

11.8	TABLE: Heating test, thermocouples (for model: LY045-022-1200E)			P
	Test voltage (V) :	106 V, 60 Hz / 254.4 V, 50 Hz		—
	Ambient (°C) :	25		—
Thermocouple locations		dT (K)		Max. dT (K)
Test supply voltage:		106 V	254,4 V	--

IEC 60335-2-29			
Clause	Requirement + Test	Result - Remark	Verdict

11.8	TABLE: Heating test, thermocouples (for model: LY045-022-1200E)		P
	Test voltage (V) :	106 V, 60 Hz / 254.4 V, 50 Hz	—
	Ambient (°C) :	25	—
Thermocouple locations	dT (K)		Max. dT (K)
Plug holder	5,4	7,0	for ref.
Primary lead wire (24AWG, 80°C, 300v)	10,7	13,8	55
PCB under D1	19,9	26,6	105
Inductor L1	27,3	34,3	65
Electrolytic Capacitor (C3)	27,3	36,1	80
PCB under U2	29,5	43,5	105
CY1	28,1	34,5	60
CY2	35,2	42,4	60
T1 winding	34,0	44,0	65
T1 core	31,3	40,3	65
PCB under D7	45,3	52,2	90
Electrolytic Capacitor (C5)	22,8	27,6	65
15.Output wire (24 AWG, 300V, 80°C)	19,8	23,7	55
Enclosure inside near T	13,4	16,9	for ref.
Enclosure inside near D7	21,2	24,8	for ref.
Enclosure outside near T	9,9	12,4	60
Enclosure outside near D7	14,2	16,7	60
Test corner floor	13,5	13,6	50

11.8	TABLE: Heating test, thermocouples (for model: LY045-045-1000E)		P
	Test voltage (V) :	106 V, 60 Hz / 254.4 V, 50 Hz	—
	Ambient (°C) :	25	—
Thermocouple locations	dT (K)		Max. dT (K)
Test supply voltage:	106 V	254,4 V	--
Plug holder	5,1	7,2	for ref.
Primay lead wire (24AWG, 80°C, 300v)	10,0	14,5	55

IEC 60335-2-29			
Clause	Requirement + Test	Result - Remark	Verdict

11.8	TABLE: Heating test, thermocouples (for model: LY045-045-1000E)		P
	Test voltage (V) :	106 V, 60 Hz / 254.4 V, 50 Hz	—
	Ambient (°C) :	25	—
Thermocouple locations	dT (K)		Max. dT (K)
PCB under D1	18,4	27,8	105
Inductor L1	26,0	37,7	65
Electrolytic Capacitor (C3)	26,6	39,8	80
PCB under U2	29,3	49,4	105
CY1	26,4	35,3	60
CY2	31,2	39,8	60
T1 winding	32,5	46,5	65
T1 core	32,9	46,4	65
PCB under D7	41,7	49,7	90
Electrolytic Capacitor (C5)	22,9	28,7	65
15.Output wire (24 AWG, 300V, 80°C)	18,9	23,5	55
Enclosure inside near T	14,2	18,9	for ref.
Enclosure inside near D7	19,9	23,8	for ref.
Enclosure outside near T	10,1	13,9	60
Enclosure outside near D7	12,4	15,0	60
Test corner floor	11,1	14,2	50

11.8	TABLE: Heating test, thermocouples (for model: LY045-068-0600E)		P
	Test voltage (V) :	106 V, 60 Hz / 254.4 V, 50 Hz	—
	Ambient (°C) :	25	—
Thermocouple locations	dT (K)		Max. dT (K)
Test supply voltage:	106 V	254,4 V	--
Plug holder	9,0	10,0	for ref.
Primay lead wire (24AWG, 80°C, 300v)	19,9	22,6	55
PCB under D1	28,5	32,5	105
Inductor L1	39,0	43,8	65

IEC 60335-2-29			
Clause	Requirement + Test	Result - Remark	Verdict

11.8	TABLE: Heating test, thermocouples (for model: LY045-068-0600E)		P
	Test voltage (V) :	106 V, 60 Hz / 254.4 V, 50 Hz	—
	Ambient (°C) :	25	—
Thermocouple locations	dT (K)		Max. dT (K)
Electrolytic Capacitor (C3)	43,3	56,7	80
PCB under U2	36,7	44,6	105
CY1	34,0	38,0	60
CY2	41,1	47,0	60
T1 winding	41,9	51,3	65
T1 core	41,1	49,8	65
PCB under D7	48,3	52,6	90
Electrolytic Capacitor (C5)	28,5	30,4	65
15.Output wire (24 AWG, 300V, 80°C)	30,6	33,6	55
Enclosure inside near T	18,7	21,3	for ref.
Enclosure inside near D7	22,5	24,5	for ref.
Enclosure outside near T	13,6	15,1	60
Enclosure outside near D7	16,5	17,8	60
Test corner floor	13,7	15,5	50

IEC 60335-2-29			
Clause	Requirement + Test	Result - Remark	Verdict

13.2	TABLE: Leakage current		P
	Heating appliances: 1,15 x rated input .....	--	—
	Motor-operated and combined appliances: 1.06 x rated voltage .....	254,4 Vac	—
Leakage current between		I (mA)	Max. allowed I (mA)
Input circuit and output circuit		0,1272 Max.	0,35
Input circuit and enclosure covered with metal foil		0,036 Max.	0,35

13.3	TABLE: Electric strength		P
Test voltage applied between:		Voltage (V)	Breakdown (Yes/No)
Input circuit and output circuit (RI)		3000	No
Input circuit and accessible enclosure (RI)		3000	No
Transformer: Primary winding and secondary winding (RI)		3000	No
Transformer: Core and secondary winding (RI)		3000	No
Line and neutral (FI)		1000	No
Note: BI=Basic insulation, SI=Supplementary insulation, DI=Double insulation, RI=Reinforced insulation, FI=Functional insulation.			

14	TABLE: Transient overvoltages					N/A
Clearance between:		CI (mm)	Required CI (mm)	Rated impulse voltage (V)	Impulse test voltage (V)	Flashover (Yes/No)
--		--	--	--	--	--

16.2	TABLE: Leakage current (model: LY045-045-1000E)		P
	Single phase appliances: 1,06 x rated voltage.....	254.4Vac	—
	Three phase appliances 1,06 x rated voltage divided by $\sqrt{3}$ :.....	--	—
Leakage current between		I (mA)	Max. allowed I (mA)
L and output terminal		0,133	0,25
N and output terminal		0,133	0,25
L and enclosure cover with metal foil		0,011	0,25

IEC 60335-2-29			
Clause	Requirement + Test	Result - Remark	Verdict

N and enclosure cover with metal foil		0,010	0,25
---------------------------------------	--	-------	------

16.3	TABLE: Electric strength		P
Test voltage applied between:		Voltage (V)	Breakdown (Yes/No)
Input circuit and output circuit (RI)		3000	No
Input circuit and accessible enclosure (RI)		3000	No
Transformer: Primary winding and secondary winding (RI)		3000	No
Transformer: Core and secondary winding (RI)		3000	No
Line and neutral (FI)		1250	No
Note: BI=Basic insulation, SI=Supplementary insulation, DI=Double insulation, RI=Reinforced insulation, FI=Functional insulation.			

17	TABLE: Overload protection, temperature rise		P
Temperature rise of part/at:		T (°C)	Max. T (°C)
Overload of output at 254,4 V supply voltage, EUT shut down immediately, no hazards			
Short-circuit of output at 254,4 V supply voltage, EUT shut down immediately, no hazards.			

19.7	TABLE: Abnormal operation, locked rotor/moving parts				N/A	
Temperature of winding		R <sub>1</sub> (Ω)	R <sub>2</sub> (Ω)	dT (K)	T (°C)	Max. T (°C)
--		--	--	--	--	--

19.9	TABLE: Abnormal operation, running overload				N/A	
Temperature of winding		R <sub>1</sub> (Ω)	R <sub>2</sub> (Ω)	dT (K)	T (°C)	Max. T (°C)
--		--	--	--	--	--

19.13	TABLE: Abnormal operation, winding temperature				N/A	
Test voltage (V) .....					—	
Ambient, t <sub>1</sub> (°C) .....					—	
Ambient, t <sub>2</sub> (°C) .....					—	
Temperature of winding		R <sub>1</sub> (Ω)	R <sub>2</sub> (Ω)	dT (K)	T (°C)	Max. T (°C)
--		--	--	--	--	--

IEC 60335-2-29			
Clause	Requirement + Test	Result - Remark	Verdict

24.1	TABLE: components				P
Object	Manufacturer/ trademark	Type / model	Technical data	Standard	Mark(s)of conformity
Enclosure and plug pin sleeve material	Bayer	6165 X(f1)	V-0, 115°C, enclosure thickness: 2,0 mm	Applicable parts of EN 60335-2-29 AfPS GS 2014:01 PAK.	Tested with appliance
Primary leading wire	Yuyao Yongfeng Electric Wire Factory	1007, 1015	80°C, 300 Vac, 24AWG min.	Applicable parts of EN 60335-2-29	Tested with appliance and UL
Primary leading wire Alt	Kunshan New Zhicheng Electronics Technologies Co., Ltd.	1007, 1015	80°C, 300 Vac, 24AWG min.	Applicable parts of IEC/EN 60335- 2-29	Tested with appliance and UL
Heat shrinkable tube	Shenzhen Woer Heat-Shrinkable Material Co Ltd	RSFR-H	125°C, 600V VW-1	Applicable parts of EN 60335-2-29	Tested with appliance and UL
PCB	Shanghai wanzheng circuit board co ltd	SWZ-1	V-0, 130 °C	UL 94, UL 796	Tested with appliance, UL
PCB Alt.	JIAXING CENTURY ELECTRONIC CO LTD	CS-1	V-0, 130 °C	UL 94, UL 796	Tested with appliance, UL
PCB Alt.	ZHEJIANG CHANGSHAN DEXUNDA ELECTRONIC TECHNOLOGY CO LTD	DXD-D1	V-0, 130 °C	UL 94, UL 796	Tested with appliance, UL
Fusing resistor (FR1)	Shen zhen great electronics co ltd	RXF-1W	1 W, 5 Ω, 250 V ac	Applicable parts of EN 60335-2-29	Tested with appliance
Fusing resistor (FR1) Alt.	Hangzhou huazu electronic co ltd	RXF-1W	1 W, 5 Ω, 250 V ac	Applicable parts of EN 60335-2-29	Tested with appliance
Y capacitor (CY1, CY2)	Jyh Chung Electronics Co Ltd	JD	400VAC, Y1 2200pF, 85°C min.	IEC/EN 60384-14	VDE 137027
Y capacitor (CY1, CY2)	Jyh Chung Electronics Co Ltd	JY	300VAC, Y2 2200pF, 85°C min.	IEC/EN 60384-14	VDE 123326
Y capacitor (CY1, CY2) Alt.	Xiamen wanming electronics co ltd	HJ	250VAC, Y2 2200pF, 85°C min.	IEC/EN 60384-14	VDE 40000353

IEC 60335-2-29			
Clause	Requirement + Test	Result - Remark	Verdict

24.1	TABLE: components				P
Object	Manufacturer/ trademark	Type / model	Technical data	Standard	Mark(s)of conformity
Y capacitor (CY1, CY2) Alt.	Nan jing yuyue electronics co ltd	CT7	250VAC, Y2 2200pF, 85°C min.	IEC/EN 60384-14	VDE 40008013
Output wire	Yuyao Yongfeng Electric Wire Factory	2468	80, °C 300V, 24AWG min.	Applicable parts of EN 60335-2-29 AfPS GS 2014:01 PAK.	Tested with appliance
Transformer (T1)	Yuyao proelec electron co., ltd	EI16	Class A	Applicable parts of EN 60335-2-29	Tested with appliance
Bobbin	Chang chun plastics co ltd	T375J	V-0, 150°C, thickness: 0.6mm min.	Applicable parts of EN 60335-2-29	Tested with appliance
Tubing	Shenzhen woer heat-shrinkable material co ltd	WF	600V, 200°C	Applicable parts of EN 60335-2-29	Tested with appliance
Tubing Alt.	Changyuan electronics (shenzhen) co ltd	CB-TT-S	600V, 200°C	Applicable parts of EN 60335-2-29	Tested with appliance
Insulation Tape	Huizhou yahua sticking tape co ltd	WF	130°C thickness: 0,06 mm	Applicable parts of EN 60335-2-29	Tested with appliance
Insulation Tape Alt.	Jingjiang fuwei adhesive product co ltd	FWS	130°C thickness: 0,06 mm	Applicable parts of EN 60335-2-29	Tested with appliance
Magnet wire (N1, N2, N4)	Shenzhen Dayang Industry Co Ltd	2UEW	130°C	Applicable parts of EN 60335-2-29	Tested with appliance
Magnet wire (N1, N2, N4) Alt.	Jiangsu dartong m & e co ltd	UEW	130°C	Applicable parts of EN 60335-2-29	Tested with appliance
Magnet wire (N1, N2, N4) Alt.	Shanghai asia pacific electric co ltd	UEW	130°C	Applicable parts of EN 60335-2-29	Tested with appliance
Magnet wire (N1, N2, N4) Alt.	Heng ya electric kun shan ltd	TYPYU-130	130°C	Applicable parts of EN 60335-2-29	Tested with appliance
Magnet wire (N1, N2, N4) Alt.	Yongshang group shanghai cable co ltd	xUEW	130°C	Applicable parts of EN 60335-2-29	Tested with appliance
Triply insulated wire (N3)	Dah jin technology co ltd	TLW-B	130°C, reinforced insulation	IEC/EN 60950-1	VDE 40008834

IEC 60335-2-29			
Clause	Requirement + Test	Result - Remark	Verdict

24.1	TABLE: components				P
Object	Manufacturer/ trademark	Type / model	Technical data	Standard	Mark(s)of conformity
Triply insulated wire (N3) Alt.	Teamwork international corporation	TIWW-B	130°C, reinforced insulation	IEC/EN 60950-1	VDE 40024497
1) An asterisk indicates a mark which assures the agreed level of surveillance					

28.1	TABLE: Threaded part torque test			N/A
Threaded part identification	Diameter of thread (mm)	Column number (I, II, or III)	Applied torque ( Nm )	
—	—	—	—	

29.1	TABLE: Clearances					P
	Overvoltage category .....	II			—	
		Type of insulation:				
Rated impulse voltage (V):	Min. cl (mm)	Basic (mm)	Supplementary (mm)	Reinforced (mm)	Functional (mm)	Verdict / Remark
330	0,2* / 0,5 / 0,8**	—	—	—	—	—
500	0,2* / 0,5 / 0,8**	—	—	—	—	—
800	0,2* / 0,5 / 0,8**	—	—	—	—	—
1 500	0,5 / 0,8** / 1,0***	—	—	—	—	—
2 500	1,5 / 2,0***	<b>2,70</b>	<b>3,20</b>	—	<b>3,50</b> <b>6,00</b> <b>3,70</b>	<b>P</b>
4 000 4 116	3,0 / 3,5*** 3,7	—	—	<b>5,07</b> <b>7,00</b> <b>7,00</b> <b>5,27</b> <b>5,04</b>	—	<b>P</b>
6 000	5,5 / 6,0***	—	—	—	—	—
8 000	8,0 / 8,5***	—	—	—	—	—
10 000	11,0 / 11,5***	—	—	—	—	—

IEC 60335-2-29			
Clause	Requirement + Test	Result - Remark	Verdict

29.1	TABLE: Clearances					P
	Overvoltage category .....	II			—	
		Type of insulation:				
Rated impulse voltage (V):	Min. cl (mm)	Basic (mm)	Supplementary (mm)	Reinforced (mm)	Functional (mm)	Verdict / Remark
<p>Supplementary information:</p> <p>*) For tracks on printed circuit boards if pollution degree 1 and 2</p> <p>**) For pollution degree 3</p> <p>***) If the construction is affected by wear, distortion, movement of the parts or during assembly</p> <p>Note: Rated voltage: 240 Vac; Max. 536 V peak, 246V r.m.s</p> <ol style="list-style-type: none"> <li>1. Functional:             <ol style="list-style-type: none"> <li>1) Line and neutral before fuse on PCB solder side: 3,50mm;</li> <li>2) Line and neutral before fuse on component side: 6,00mm;</li> <li>3) Two poles of fuse: 3,70mm;</li> </ol> </li> <li>2. Basic insulation: Two pins of CY1: 2,70mm;</li> <li>3. Supplementary insulation: Two pins of CY2: 3,20mm;</li> <li>4. Reinforced:             <ol style="list-style-type: none"> <li>1) Live parts to accessible enclosure: 5,07mm;</li> <li>2) Primary circuit to Secondary circuit on PCB solder side: 7,00mm;</li> <li>3) Primary circuit to Secondary circuit on component side: 7,00mm;</li> <li>4) Secondary winding to core on transformer: 5,27mm;</li> <li>5) Primary winding to Secondary winding on transformer: 5,04mm</li> </ol> </li> </ol>						

29.2	TABLE: Creepage distances, basic, supplementary and reinforced insulation										P
Working voltage (V)	Creepage distance (mm)										Verdict
	Pollution degree							Type of insulation			
	1	2			3						
		Material group			Material group						
		I	II	IIIa/IIIb	I	II	IIIa/IIIb*	B**	S**	R**	
≤50	0,18	0,6	0,85	1,2	1,5	1,7	1,9		—	—	
≤50	0,18	0,6	0,85	1,2	1,5	1,7	1,9	—		—	
≤50	0,36	1,2	1,7	2,4	3,0	3,4	3,8	—	—	—	
125	0,28	0,75	1,05	1,5	1,9	2,1	2,4		—	—	

IEC 60335-2-29			
Clause	Requirement + Test	Result - Remark	Verdict

29.2	TABLE: Creepage distances, basic, supplementary and reinforced insulation										P
Working voltage (V)	Creepage distance (mm) Pollution degree							Type of insulation			Verdict
	1	2			3			B**	S**	R**	
	Material group				Material group						
		I	II	IIIa/IIIb	I	II	IIIa/IIIb*	B**	S**	R**	Verdict
125	0,28	0,75	1,05	1,5	1,9	2,1	2,4	—		—	—
125	0,56	1,5	2,1	3,0	3,8	4,2	4,8	—	—		—
250	0,56	1,25	1,8	<b>2,5</b>	3,2	3,6	4,0	<b>2,70</b>	—	—	<b>P</b>
250	0,56	1,25	1,8	2,5	3,2	3,6	4,0	—	3,20	—	—
250	1,12	2,5	3,6	<b>5,0</b>	6,4	7,2	8,0	—	—	<b>5,07</b> <b>7,00</b> <b>7,00</b> <b>5,27</b> <b>5,04</b>	<b>P</b>
400	1,0	2,0	2,8	4,0	5,0	5,6	6,3		—	—	—
400	1,0	2,0	2,8	4,0	5,0	5,6	6,3	—		—	—
400	2,0	4,0	5,6	8,0	10,0	11,2	12,6	—	—		—
500	1,3	2,5	3,6	5,0	6,3	7,1	8,0		—	—	—
500	1,3	2,5	3,6	5,0	6,3	7,1	8,0	—		—	—
500	2,6	5,0	7,2	10,0	12,6	14,2	16,0	—	—		—
>630 and ≤800	1,8	3,2	4,5	6,3	8,0	9,0	10,0		—	—	—
>630 and ≤800	1,8	3,2	4,5	6,3	8,0	9,0	10,0	—		—	—
>630 and ≤800	3,6	6,4	9,0	12,6	16,0	18,0	20,0	—	—		—
>800 and ≤1000	2,4	4,0	5,6	8,0	10,0	11,0	12,5		—	—	—
>800 and ≤1000	2,4	4,0	5,6	8,0	10,0	11,0	12,5	—		—	—
>800 and ≤1000	4,8	8,0	11,2	16,0	20,0	22,0	25,0	—	—		—
>1000 and ≤1250	3,2	5,0	7,1	10,0	12,5	14,0	16,0		—	—	—
>1000 and ≤1250	3,2	5,0	7,1	10,0	12,5	14,0	16,0	—		—	—
>1000 and ≤1250	6,4	10,0	14,2	20,0	25,0	28,0	32,0	—	—		—
>1250 and ≤1600	4,2	6,3	9,0	12,5	16,0	18,0	20,0		—	—	—

IEC 60335-2-29			
Clause	Requirement + Test	Result - Remark	Verdict

29.2	TABLE: Creepage distances, basic, supplementary and reinforced insulation										P
Working voltage (V)	Creepage distance (mm)							Type of insulation			Verdict
	Pollution degree										
	1	2			3						
		Material group			Material group						
		I	II	IIIa/IIIb	I	II	IIIa/IIIb*	B**	S**	R**	Verdict
>1250 and ≤1600	4,2	6,3	9,0	12,5	16,0	18,0	20,0	—		—	—
>1250 and ≤1600	8,4	12,6	18,0	25,0	32,0	36,0	40,0	—	—		—
>1600 and ≤2000	5,6	8,0	11,0	16,0	20,0	22,0	25,0		—	—	—
>1600 and ≤2000	5,6	8,0	11,0	16,0	20,0	22,0	25,0	—		—	—
>1600 and ≤2000	11,2	16,0	22,0	32,0	40,0	44,0	50,0	—	—		—
>2000 and ≤2500	7,5	10,0	14,0	20,0	25,0	28,0	32,0		—	—	—
>2000 and ≤2500	7,5	10,0	14,0	20,0	25,0	28,0	32,0	—		—	—
>2000 and ≤2500	15,0	20,0	28,0	40,0	50,0	56,0	64,0	—	—		—
>2500 and ≤3200	10,0	12,5	18,0	25,0	32,0	36,0	40,0		—	—	—
>2500 and ≤3200	10,0	12,5	18,0	25,0	32,0	36,0	40,0	—		—	—
>2500 and ≤3200	20,0	25,0	36,0	50,0	64,0	72,0	80,0	—	—		—
>3200 and ≤4000	12,5	16,0	22,0	32,0	40,0	45,0	50,0		—	—	—
>3200 and ≤4000	12,5	16,0	22,0	32,0	40,0	45,0	50,0	—		—	—
>3200 and ≤4000	25,0	32,0	44,0	64,0	80,0	90,0	100,0	—	—		—
>4000 and ≤5000	16,0	20,0	28,0	40,0	50,0	56,0	63,0		—	—	—
>4000 and ≤5000	16,0	20,0	28,0	40,0	50,0	56,0	63,0	—		—	—
>4000 and ≤5000	32,0	40,0	56,0	80,0	100,0	112,0	126,0	—	—		—
>5000 and ≤6300	20,0	25,0	36,0	50,0	63,0	71,0	80,0		—	—	—
>5000 and ≤6300	20,0	25,0	36,0	50,0	63,0	71,0	80,0	—		—	—
>5000 and ≤6300	40,0	50,0	72,0	100,0	126,0	142,0	160,0	—	—		—
>6300 and ≤8000	25,0	32,0	45,0	63,0	80,0	90,0	100,0		—	—	—
>6300 and ≤8000	25,0	32,0	45,0	63,0	80,0	90,0	100,0	—		—	—
>6300 and ≤8000	50,0	64,0	90,0	126,0	160,0	180,0	200,0	—	—		—
>8000 and ≤10000	32,0	40,0	56,0	80,0	100,0	110,0	125,0		—	—	—

IEC 60335-2-29			
Clause	Requirement + Test	Result - Remark	Verdict

29.2	TABLE: Creepage distances, basic, supplementary and reinforced insulation										P
Working voltage (V)	Creepage distance (mm) Pollution degree							Type of insulation			Verdict
	1	2			3			B**	S**	R**	
	Material group			Material group							
		I	II	IIIa/IIIb	I	II	IIIa/IIIb*				
>8000 and ≤10000	32,0	40,0	56,0	80,0	100,0	110,0	125,0	—		—	
>8000 and ≤10000	64,0	80,0	112,0	160,0	200,0	220,0	250,0	—	—	—	
>10000 and ≤12500	40,0	50,0	71,0	100,0	125,0	140,0	160,0		—	—	
>10000 and ≤12500	40,0	50,0	71,0	100,0	125,0	140,0	160,0	—		—	
>10000 and ≤12500	80,0	100,0	142,0	200,0	250,0	280,0	320,0	—	—	—	

Supplementary information:

\*) Material group IIIb is allowed if the working voltage does not exceed 50 V

\*\*) B = Basic insulation, S = Supplementary insulation, R = Reinforced insulation

Note: Rated voltage: 240 Vac; Max. 536 V peak, 246V r.m.s

- Basic insulation: Two pins of CY1: 2,70mm;
- Supplementary insulation: Two pins of CY2: 3,20mm;
- Reinforced:
  - Live parts to accessible enclosure: 5,07mm;
  - Primary circuit to Secondary circuit on PCB solder side: 7,00mm;
  - Primary circuit to Secondary circuit on component side: 7,00mm;
  - Secondary winding to core on transformer: 5,27mm;
  - Primary winding to Secondary winding on transformer: 5,04mm

29.2	TABLE: Creepage distances, functional insulation								P
Working voltage (V)	Creepage distance (mm) Pollution degree							Verdict / Remark	
	1	2			3				
	Material group			Material group					
		I	II	IIIa/IIIb	I	II	IIIa/IIIb*		
≤10	0,08	0,4	0,4	0,4	1,0	1,0	1,0	—	
50	0,16	0,56	0,8	1,1	1,4	1,6	1,8	—	

IEC 60335-2-29									
Clause	Requirement + Test							Result - Remark	Verdict

125	0,25	0,71	1,0	1,4	1,8	2,0	2,2	—
250	0,42	1,0	1,4	<b>2,0</b>	2,5	2,8	3,2	<b>P</b> <b>5,70</b> <b>6,00</b> <b>3,70</b>
400	0,75	1,6	2,2	3,2	4,0	4,5	5,0	—
500	1,0	2,0	2,8	4,0	5,0	5,6	6,3	—
>630 and ≤800	1,8	3,2	4,5	6,3	8,0	9,0	10,0	—
>800 and ≤1000	2,4	4,0	5,6	8,0	10,0	11,0	12,5	—
>1000 and ≤1250	3,2	5,0	7,1	10,0	12,5	14,0	16,0	—
>1250 and ≤1600	4,2	6,3	9,0	12,5	16,0	18,0	20,0	—
>1600 and ≤2000	5,6	8,0	11,0	16,0	20,0	22,0	25,0	—
>2000 and ≤2500	7,5	10,0	14,0	20,0	25,0	28,0	32,0	—
>2500 and ≤3200	10,0	12,5	18,0	25,0	32,0	36,0	40,0	—
>3200 and ≤4000	12,5	16,0	22,0	32,0	40,0	45,0	50,0	—
>4000 and ≤5000	16,0	20,0	28,0	40,0	50,0	56,0	63,0	—
>5000 and ≤6300	20,0	25,0	36,0	50,0	63,0	71,0	80,0	—
>6300 and ≤8000	25,0	32,0	45,0	63,0	80,0	90,0	100,0	—
>8000 and ≤10000	32,0	40,0	56,0	80,0	100,0	110,0	125,0	—
>10000 and ≤12500	40,0	50,0	71,0	100,0	125,0	140,0	160,0	—

Supplementary information:

\*) Material group IIIb is allowed if the working voltage does not exceed 50 V

Note: Rated voltage: 240 Vac; Max. 536 V peak, 246V r.m.s

1. Functional:

- 1) Line and neutral before fuse on PCB solder side: 5,70mm;
- 2) Line and neutral before fuse on component side: 6,00mm;
- 3) Two poles of fuse: 3,70mm;



IEC 60335-2-29																				
Clause	Requirement + Test																			
30	TABLE: Resistance to heat and fire																			
Object/ part No.	Manufacturer/ trademark	Type/ model	Ball pressure test °C				Glow wire test (GWT) °C						Glow-wire flammability index (GWFI) °C				Glow-wire ignition temp. (GWIT) °C		Needle- flame test (NFT)	Verdict
			75	125	cl. 11 +40	cl. 19 +25	550	650		750		850	550	650	750	850	675	775		
								$t_e$	$t_i$	$t_e$	$t_i$	0	0							
Plug pin holder material (Enclosure)	Bayer	6165 X(f1)	0.89 mm	--	--	--	--	--	--	No fla me	No fla me	--	--	--	--	--	--	--	--	P
PCB	Shanghai wanzheng circuit board co ltd	SWZ-1	1.21 mm	--	--	--	--	--	--	--	--	No fla me	--	--	--	--	--	--	--	P
Bobbin	Chang chun plastics co ltd	T375J	0.84 mm	--	--	--	--	--	--	--	--	No fla me	--	--	--	--	--	--	--	P
Supplementary information:																				

- 1) Parts of material classified at least HB40 or if relevant HBF
- 2) Parts of material classified as V-0 or V-1
- 3) Flame persisting longer than 2 s (=  $t_e - t_i$ ) need only be reported for unattended appliances
- 4) Surrounding parts subjected to the needle-flame test of annex E
- 5) Base material classified as V-0 or if relevant VTM-0
- 6) The GWIT pre-selection option, the 850 °C GWF1 pre-selection option, and the 850 °C GWT are not applicable for attended appliances

Appendix : European Group Differences			
clause	Requirement - Test	Result - Remark	Verdict

<b>ATTACHMENT TO TEST REPORT IEC 60335-2-29</b> <b>EUROPEAN GROUP DIFFERENCES AND NATIONAL DIFFERENCES</b> Safety of household and similar electrical appliances Part 2: Particular requirements for battery chargers	
<b>Differences according to :</b>	EN 60335-2-29:2004 + A2:2010 used in conjunction with EN 60335-1:2012 + A11:2014 EN 62233:2008
<b>Attachment Form No. :</b>	EU_GD_IEC60335_2_29I
<b>Attachment Originator :</b>	SIQ
<b>Master Attachment :</b>	2013-04
<b>Copyright © 2013 IEC System for Conformity Testing and Certification of Electrical Equipment (IECEE), Geneva, Switzerland. All rights reserved.</b>	

<b>Annex EN 62233:2008</b>			
Clause	Requirement + Test	Result - Remark	Verdict
<b>EMF- ELECTROMAGNETICS FIELDS</b>			
	The tested product also complies with the requirements of EN 62233:2008		—
	Limit .....100%	Measured max. 0,243%	P

<b>Group/CENELEC Common Differences to IEC 60335-1:2010 (5<sup>th</sup> Edition)</b>			
<b>CENELEC COMMON MODIFICATIONS</b>			
6.1	Delete “class 0” and “class 01”		P
7.1	Single-phase appliances to be connected to the supply mains: 230 V covered		P
	Multi-phase appliances to be connected to the supply mains: 400 V covered		N/A
7.10	Devices used to start/stop operational functions of the appliance distinguished from other manual devices by means of shape, size, surface texture, position, etc.		N/A
	An indication that the device has been operated is given by:		N/A
	<ul style="list-style-type: none"> <li>a tactile feedback, or</li> </ul>		N/A
	<ul style="list-style-type: none"> <li>an audible and visual feedback</li> </ul>		N/A
7.12	The instructions include the substance of the following:		P

Appendix : European Group Differences			
clause	Requirement - Test	Result - Remark	Verdict
	- this appliance can be used by children aged from 8 years and above and persons with reduced physical, sensory or mental capabilities or lack of experience and knowledge if they have been given supervision or instruction concerning use of the appliance in a safe way and understand the hazards involved		P
	- children shall not play with the appliance		P
	- cleaning and user maintenance shall not be made by children without supervision		P
7.12.Z1	The specific instructions related to the safe operation of this appliance is collated together in the front section of the user instructions		P
	The height of the characters, measured on the capital letters, is at least 3 mm		P
	These instructions are also available in an alternative format, e.g. on a website		P
8.1.1	Also test probe 18 of EN 61032 is applied		P
	The appliance being in every possible position during the test		P
	The force on the probe in the straight position is increased to 10 N when probe 18 is used		P
	When using test probe 18 the appliance is fully assembled as in normal use without any parts removed, and		P
	parts intended to be removed for user maintenance are also not removed		N/A
8.2	Compliance is checked by applying the test probes of EN 61032		P
	For built-in appliances and fixed appliances, the test probe B and probe 18 of EN 61032 are applied only after installation		N/A
11.8	Footnotes to “External enclosure of motor-operated appliances” to be taken into account		N/A
15.1.2	Appliances with an automatic cord reel tested with the cord in the most unfavourable position so that the reeling of the wet cord may affect electrical insulation during operation, the cord not being dried before reeling		N/A

Appendix : European Group Differences			
clause	Requirement - Test	Result - Remark	Verdict
20.2	When using the test probe similar to test probe B with a circular stop face, the accessories and detachable covers are removed		N/A
	Test probe 18 applied with a force of 2,5N on the appliance fully assembled		P
24.1	Components comply with the safety requirements specified in the relevant standards as far as they reasonably apply		P
	The requirements of Clause 29 of this standard apply between live parts of components and accessible parts of the appliance.		P
	The requirements of 30.2 of this standard apply to parts of non-metallic material in components including parts of non-metallic material supporting current-carrying connections inside components		P
	Components that have not been previously tested or do not comply with the standard for the relevant component are tested according to the requirements of 30.2		P
	Components that have been previously tested and shown to comply with the resistance to fire requirements in the standard for the relevant component need not be retested provided that:		P
	- the severity specified in the component standard is not less than the severity specified in 30.2, and		P
	- the test report for the component states whether it complied with the standard for the relevant component with or without flame, flames not exceeding 2 s during the test are ignored		P
	Unless components have been previously tested and found to comply with the relevant standard for the number of cycles specified, they are tested in accordance with 24.1.1 to 24.1.9		P
	For components mentioned in 24.1.1 to 24.1.9, no additional tests specified in the relevant standard for the component are necessary other than those specified in 24.1.1 to 24.1.9		P
	Components that have not been separately tested and found to comply with the relevant standard, and		N/A
	components that are not marked or not used in accordance with their marking,		N/A

Appendix : European Group Differences			
clause	Requirement - Test	Result - Remark	Verdict
	are tested in accordance with the conditions occurring in the appliance, the number of samples being that required by the relevant standard		N/A
	Lamp holders and starter holders that have not been previously tested and found to comply with the relevant standard are tested as a part of the appliance and additionally comply with the gauging and interchangeability requirements of the relevant standard under the conditions occurring in the appliance		N/A
	Where the relevant standard specifies these gauging and interchangeability requirements at elevated temperatures, the temperatures measured during the tests of Clause 11 are used		P
	Plugs and socket-outlets and other connecting devices of interconnection cords are not interchangeable with plugs and socket-outlets listed in IEC/TR 60083 or IEC 60906-1, or		P
	with connectors and appliance inlets complying with the standard sheets of IEC 60320-1,		P
	if direct supply to these parts from the supply mains gives rise to a hazard		N/A
24.1.7	If the remote operation of the appliance is via a telecommunication network, the relevant standard for the telecommunication interface circuitry in the appliance is EN 41003		N/A
	Compliance with Clause 8 of this standard is not impaired by connecting the appliance to a device covered by EN 41003		N/A
24.Z1	For motor running capacitors (IEC 60252-1 type P2) with a metallic enclosure having an overpressure fuse the flame testing of internal plastic parts supporting current carrying connections as required in 30.2.2 and 30.2.3.1 is not necessary		N/A
25.6	Supply cords of single-phase portable appliances having a rated current not exceeding 16 A, fitted with a plug complying with the following standard sheets of IEC/TR 60083:		N/A

Appendix : European Group Differences			
clause	Requirement - Test	Result - Remark	Verdict
	- for Class I appliances: standard sheet C2b, C3b or C4 .....		N/A
	- for Class II appliances: standard sheet C5 or C6 .....		N/A
25.7	Rubber sheathed cords (60245 IEC 53) are not suitable for appliances intended to be used outdoors or when they are liable to be exposed to significant amount of ultraviolet radiation		N/A
	Halogen-free thermoplastic compound sheathed supply cords have properties at least those of:		N/A
	<ul style="list-style-type: none"> <li>halogen-free thermoplastic compound sheathed cords (H03Z1Z1H2-F or H03Z1Z1-F), for appliances having a mass not exceeding 3 kg</li> </ul>		N/A
	<ul style="list-style-type: none"> <li>halogen-free thermoplastic compound sheathed cords (H05Z1Z1H2-F or H05Z1Z1-F), for other appliances</li> </ul>		N/A
	Cross-linked halogen-free compound sheathed supply cords have properties at least those of cross-linked halogen-free compound sheathed cords (H07ZZ-F)		N/A
26.11	Conductors connected by soldering are not considered to be positioned or fixed so that reliance is not placed upon the soldering alone to maintain them in position unless they are held in place near the terminals independently of the solder		P
29.3.Z1	Appliance constructed so that if there is a possibility of damaging the insulation during installation, the insulation withstands the scratch and penetration test of 21.2		N/A
32	Compliance regarding electromagnetic fields is checked according to EN 62233		P

Appendix : European Group Differences			
clause	Requirement - Test	Result - Remark	Verdict
Annex I, 19.I.101	The appliance is supplied at rated voltage and operated under normal operation with each of the fault conditions specified		N/A
	The duration of the test is as specified in 19.7		N/A
<b>ZA</b>	<b>ANNEX ZA (NORMATIVE) SPECIAL NATIONAL CONDITIONS</b>		N/A
	<b>Norway</b>		N/A
19.5	The test is also applicable to appliances intended to be permanently connected to fixed wiring		N/A
	<b>Norway</b>		N/A
22.2	The second paragraph of this subclause, dealing with single-phase, permanently connected class I appliances having heating elements, is not applicable due to the supply system		N/A
	<b>All CENELEC countries</b>		N/A
25.6 and 25.25	Information concerning National plug and socket-outlets is available from the CENELEC website. Normative national requirements concerning plug and socket-outlets are shown in the relevant National standard		N/A
	<b>Ireland and United Kingdom</b>		N/A
25.8	In the table, the lines for 10 A and 16 A are replaced by:		N/A
	> 10 and ≤ 13 1,25		N/A
	> 13 and ≤ 16 1,5		N/A
<b>ZB</b>	<b>ANNEX ZB (INFORMATIVE) A-DEVIATIONS</b>		N/A
	<b>Ireland</b>		N/A
25.6	These regulations apply to all plugs for domestic use at a voltage of not less than 200 V and in general allow only plugs complying with I.S. 401:1997, or equivalent, to be fitted to domestic appliances		N/A
	<b>United Kingdom</b>		N/A

Appendix : European Group Differences			
clause	Requirement - Test	Result - Remark	Verdict
25.6	These regulations apply to all plugs for domestic use at a voltage of not less than 200 V and in general allow only plugs to BS 1363 to be fitted to domestic appliances. It also allows plugs to BS 4573 and EN 50075 to be fitted to shavers and toothbrushes		N/A
<b>ZC</b>	<b>ANNEX ZC (NORMATIVE) NORMATIVE REFERENCES TO INTERNATIONAL PUBLICATIONS WITH THEIR CORRESPONDING EUROPEAN PUBLICATIONS</b>		P
	A list of referenced documents in this standard		P
<b>ZD</b>	<b>ANNEX ZD (INFORMATIVE) IEC and CENELEC CODE DESIGNATIONS FOR FLEXIBLE CORDS</b>		N/A
	A table with IEC and CENELEC code designations for flexible cords		N/A
<b>ZE</b>	<b>ANNEX ZE (INFORMATIVE) SPECIFIC ADDITIONAL REQUIREMENTS FOR APPLIANCES AND MACHINES INTENDED FOR COMMERCIAL USE</b>		N/A
7.1	Business name and full address of the manufacturer and, where applicable, his authorized representative..... :		N/A
	Model or type reference .....		N/A
	Serial number, if any .....		N/A
	Production year		N/A
	Designation of the appliance .....		N/A
7.12	Instructions provided with the appliance so that the appliance can be used safely		N/A
	The instructions contain at least the following information:		N/A
	- the business name and full address of the manufacturer and, where applicable, his authorized representative		N/A
	- model or type reference of the appliance as marked on the appliance itself, except for the serial number		N/A
	- the designation of the appliance together with its explanation in case it is given by a combination of letters and/or numbers		N/A
	- the general description of the appliance, when needed due to the complexity of the appliance		N/A

Appendix : European Group Differences			
clause	Requirement - Test	Result - Remark	Verdict
	- specific precautions if required during installation, operation, adjusting, user maintenance, cleaning, repairing or moving		N/A
	- when needed drawings, diagrams, descriptions and explanations necessary for the safe use and user maintenance of the appliance		N/A
	- the possible reasonably foreseeable misuse and, whenever relevant, a warning against the effects it may have on the safe use of the appliance		N/A
	The words "Original instructions" appear on the language version(s) verified by the manufacturer or by the authorized representative		N/A
	When a translation of the original instructions has been provided by a person introducing the appliance on the market; the meaning of the sentence "Translation of the original instructions" appear in the relevant instructions delivered with the appliance		N/A
	The instructions for maintenance/service to be done by specialized personnel, mandated by the manufacturer or the authorized representative may be supplied in only one Community language which the specialized personnel understand		N/A
	The instructions indicate the type and frequency of inspections and maintenance required for safe operation including the preventive maintenance measures		N/A
7.12.ZE1	If needed for specific appliances, the following information to be given:		N/A
	<ul style="list-style-type: none"> <li>on use, transportation, assembly, dismantling when out of service, testing or foreseeable breakdowns, if these operations have consequences on stability of the appliance in order to avoid overturning, falling or uncontrolled movements of the appliance or of its component parts</li> </ul>		N/A
	<ul style="list-style-type: none"> <li>on how to maintain adequate mechanical stability when in use, during transportation, assembly, dismantling, scrapping and any other action involving the appliance</li> </ul>		N/A

Appendix : European Group Differences			
clause	Requirement - Test	Result - Remark	Verdict
	<ul style="list-style-type: none"> <li>on the protective measures to be taken by the user, including, where appropriate, the personal protective equipment to be provided</li> </ul>		N/A
	<ul style="list-style-type: none"> <li>on the operating method to be followed in the event of accident or breakdown; if a blockage is likely to occur the operating method to safely unblock the appliance</li> </ul>		N/A
	<ul style="list-style-type: none"> <li>on the specifications on the spare parts to be used, when these affect the health and safety of the operator</li> </ul>		N/A
	<ul style="list-style-type: none"> <li>on airborne noise emissions, determined and declared in accordance with the relevant Part 2, which includes:</li> </ul>		N/A
	70 - the A-weighted emission sound pressure level at workstations, where this exceeds dB(A) ..... ;		N/A
	dB(A), - where this level does not exceed 70 this fact is indicated		N/A
	- the peak C-weighted instantaneous sound pressure value at workstations, where this exceeds 63 Pa (130 dB in relation to 20 μPa)..... :		N/A
	- the A-weighted sound power level emitted by the machinery, where the A-weighted emission sound pressure level at workstations exceeds 80 dB(A)..... :		N/A
7.12.ZE2	The instructions includes a warning to disconnect the appliance from its power source during service and when replacing parts		N/A
	If the removal of the plug is foreseen, it is clearly indicated that the removal of the plug has to be such that an operator can check from any of the points to which he has access that the plug remains removed		N/A
	If this is not possible, due to the construction of the appliance or its installation, a disconnection with a locking system in the isolated position is provided		N/A
19.11.4.8	The appliance continues to operate, without causing any hazard to the user, from the same point in its operating cycle at which the voltage fluctuation occurred, or		N/A

Appendix : European Group Differences			
clause	Requirement - Test	Result - Remark	Verdict
	a manual operation is required to restart it		N/A
20.1	Appliances and their components and fittings have adequate mechanical stability during transportation, assembly, dismantling and any other action involving the appliance		N/A
20.2	Dangerous moving transmission parts safeguarded either by design or guards		N/A
	When guards are used, they are fixed guards, interlocking movable guards or protective devices		N/A
	Moving parts directly involved in the function of the appliance which cannot be made completely inaccessible fitted with:		N/A
	- fixed guards or interlocking movable guards preventing access to those sections of the parts that are not used in the work, and		N/A
	- adjustable guards restricting access to those sections of the moving parts where access is necessary		N/A
	Interlocking movable guards used where frequent access is required		N/A
21.1	Appliances and their components and fittings have adequate mechanical strength and is constructed to withstand such rough handling that may be expected in normal use, during transportation, assembly, dismantling, scrapping and any other action involving the appliance		N/A
22.ZE.1	For appliances provided with a seat, the seat gives adequate stability		N/A
	The distance between the seat and the control devices capable of being adapted to the operator		N/A
22.ZE.2	For appliances provided with separate devices for the start and the stop functions, the stop function is unambiguously identifiable and does always override the start function		N/A
	For appliances provided with one device performing the start and the stop function, the stop function is unambiguously identifiable and does always override the start function		N/A
22.ZE.3	Appliances designed in such a way that incorrect mounting is avoided, if this can lead to an unsafe situation		N/A

Appendix : European Group Differences			
clause	Requirement - Test	Result - Remark	Verdict
	If this is not possible, information on the correct mounting is given directly on the part and/or the enclosure		N/A
22.ZE.4	Where the weight, size or shape prevents appliances from being moved manually, they are fitted with attachments for lifting gear, or		N/A
	so designed that they can be fitted with such attachments, or		N/A
	be shaped in such a way that standard lifting gear can easily be used		N/A
	Appliances to be moved manually are constructed or equipped so that they can be moved easily and safely		N/A
22.ZE.5	The fixing systems of fixed guards which prevent access to dangerous moving transmission parts only removable with the use of tools		N/A
	If such guards have to be removed by the user for routine cleaning or maintenance their fixing systems remain attached to the fixed guards or to the machine after removal		N/A
	Where possible, guards are incapable of remaining in place without their fixings		N/A
	This does not apply if, after removal of the screws, or if the component is incorrectly repositioned, the appliance becomes inoperative		N/A
	Movable guards are interlocked		N/A
	The interlocking devices prevent the start of hazardous appliance functions until the guards are fixed in their position, and give a stop command whenever they are no longer closed		N/A
	Where it is possible for an operator to reach the danger zone before the risk due to hazardous appliance functions has ceased, movable guards associated with a guard locking device in addition to an interlocking device that:		N/A
	- prevents the start of hazardous appliance functions until the guard is closed and locked, and		N/A
	- keeps the guard closed and locked until the risk of injury from the hazardous appliance functions has ceased		N/A
	Interlocking movable guards remain attached to the appliance when open, and		N/A

Appendix : European Group Differences			
clause	Requirement - Test	Result - Remark	Verdict
	they are designed and constructed in such a way that they can be adjusted only by means of an intentional action		N/A
22.ZE.6	Interlocking movable guards designed in such a way that the absence or failure of one of their components prevents starting or stops the hazardous appliance functions		N/A
	The guard is opened to the extent needed to cause the interlocking to operate and is then closed, the number of operations being defined in the specific Part 2 .....		N/A
	After this test any defect that may be expected in normal use is applied to the interlock system, including interruption of the supply, only one defect being simulated at a time		N/A
	After these tests the interlock system is fit for further use		N/A
22.ZE.7	Adjustable guards restricting access to areas of the moving parts strictly necessary for the work are:		N/A
	- adjustable manually or automatically, depending on the type of work involved, and		N/A
	- readily adjustable without the use of tools		N/A
22.ZE.8	In case of interruption, re-establishment after an interruption or fluctuation in whatever manner of the power supply, the appliance does not restart		N/A
	However, automatic restarting of the operation is allowed if the appliance may continue to operate, without causing any hazard to the user, from the same point in its operating cycle at which the voltage interruption or fluctuation occurred		N/A
22.ZE.9	Appliances fitted with means to isolate them from all energy sources		N/A
	Such isolators are clearly identified, and		N/A
	they are capable of being locked if reconnection endanger persons		N/A
	After the energy source is disconnected, it is possible to dissipate any energy remaining or stored in the circuits of the appliance without risk to persons		N/A

Appendix : European Group Differences			
clause	Requirement - Test	Result - Remark	Verdict

<b>ZF</b>	<b>ANNEX ZF (INFORMATIVE) CRITERIA APPLIED FOR THE ALLOCATION OF PRODUCTS COVERED BY STANDARDS IN THE EN 60335 SERIES UNDER LVD OR MD</b>		P
	List of standards under CENELEC/TC61 with the allocation under the LVD (Low Voltage Directive) or the MD (Machinery Directive)..... :		P
<b>ZG</b>	<b>ANNEX ZG (NORMATIVE) UV APPLIANCES</b>		N/A
	The following modifications to this standard apply to appliances having UV emitters		N/A
	This annex is not applicable to appliances covered by the scopes of IEC 60335-2-27, IEC 60335-2-59 or IEC 60335-2-109		N/A
7.12.ZG	The instructions for appliances incorporating UVC emitters include the substance of the following: WARNING — This appliance contains a UV emitter. Do not stare at the light source		N/A
32	For appliances incorporating UV emitters the manufacturer delivers a declaration providing evidence that the plastic material exposed to the radiation is UV resistant		N/A
<b>ZZ</b>	<b>ANNEX ZZ (INFORMATIVE) COVERAGE OF ESSENTIAL REQUIREMENTS OF EC DIRECTIVES</b>		P
	Description of the relation between this European standard and the LVD (Low Voltage Directive, 2006/95/EC) and the MD (Machinery Directive, 2006/42/EC)		P

Appendix : Circuit diagram

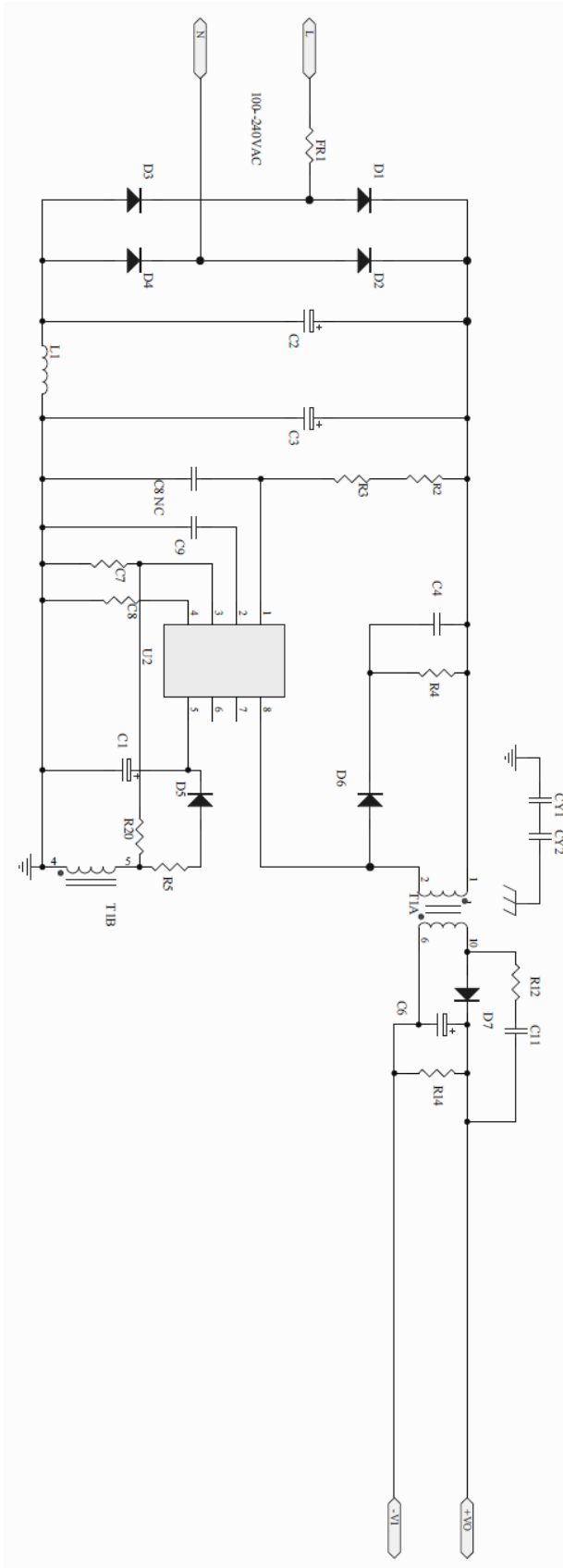

Input: 100-240 V~, 50/60 Hz, 0,2 A max., class II  
Output: 2,2-6,8 V  $\overline{\text{---}}$ , 0050-1200 mA max., 4,5 W max.

Appendix: PCB Layout

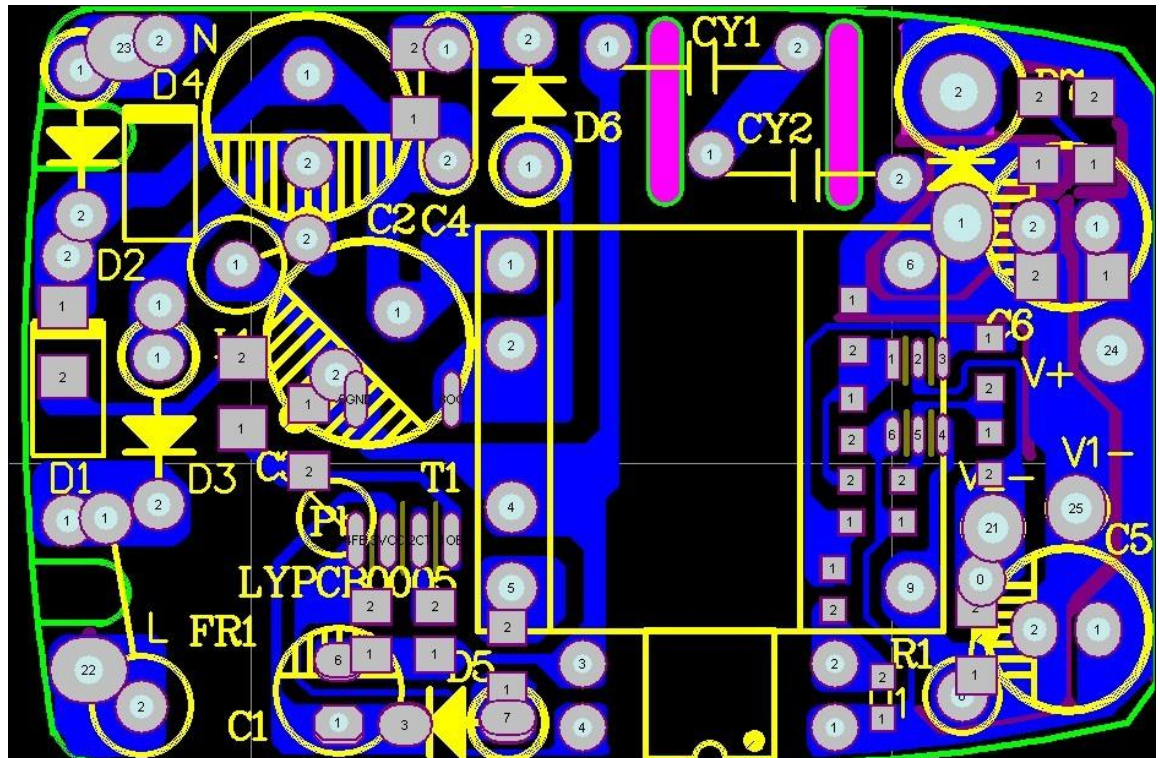
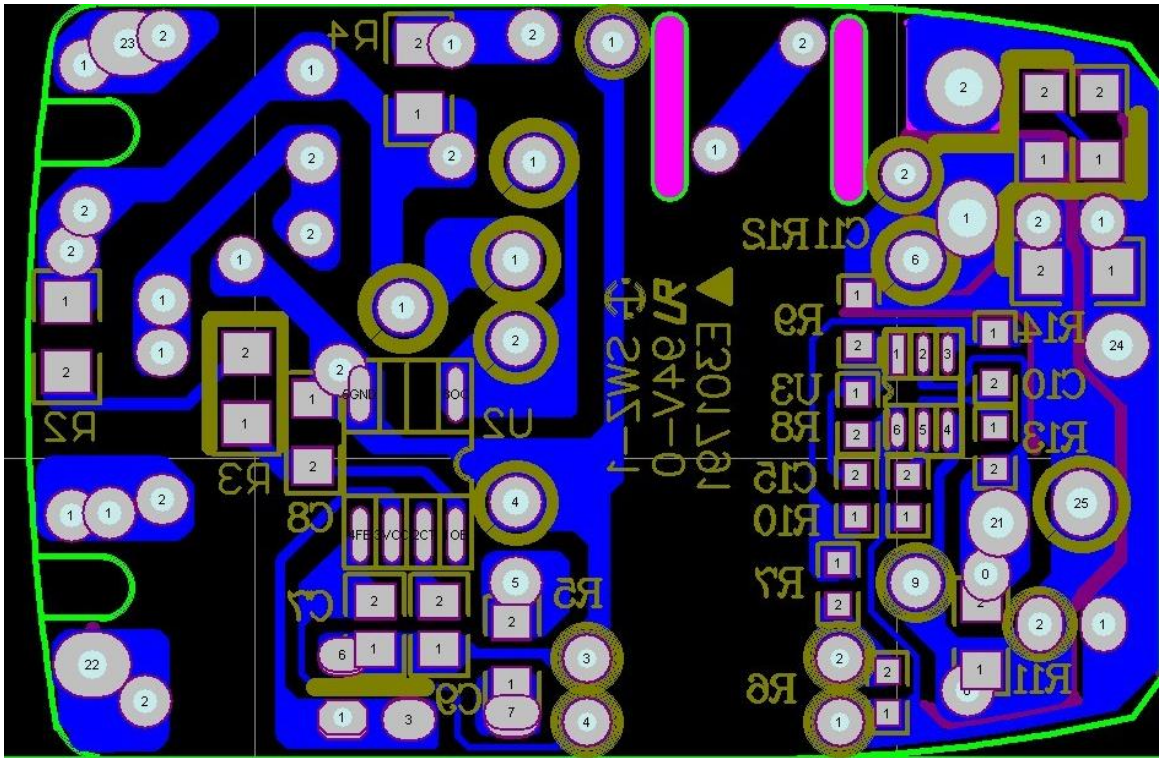

Appendix: Transformer structure (representative)

2,0 for transformer T1 drawing

teflon tube

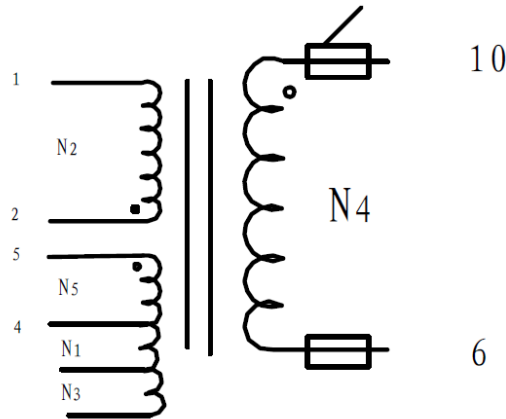

S/No.	Winding instructions
N1	Connect the $\Phi 0.15$ 2UEW wire to pin1. Start at pin 4, winding 43 turns, wind a layer of $\Phi 0.15$ 2UEW wire. Wind 2 layers of tape.
N2	Start at pin 2, wind of $\Phi 0.15$ 2UEW wire, winding 129 turns, total 3 layers, finish at pin 1. Wind 2 layers of tape.
N3	Connect the $\Phi 0.15$ 2UEW wire to pin1. Start at pin 4, winding 43 turns, wind a layer of $\Phi 0.15$ 2UEW wire. Wind 2 layers of tape.
N4	Start at pin 10, winding a layer of $\Phi 0.3 \times 2$ 7 turns, finish at pin 6. Wind 2 layers of tape. Wrap the start and the finish wire with teflon tube.
N5	Start at pin 5, wind of $\Phi 0.15$ 2UEW wire, winding 28 turns, finish at pin 4. Wind 3 layers of tape.

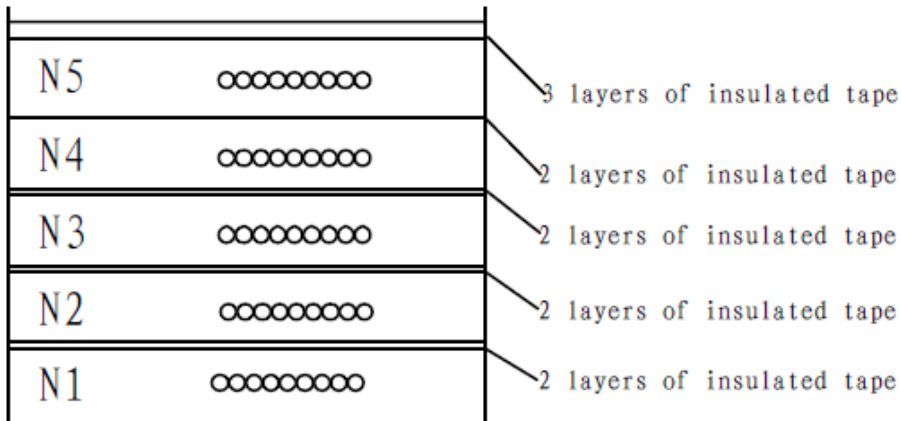

3. Characteristics requirements (10KHz):

- 1).  $L_{1-2} = 2.0 \text{ mH} \pm 10\%$
- 2). Inductance leakage:  $L_{1-2} < 100 \mu\text{H}$  (short pin8-10)
- 3). High Voltage: P-S AC3750V 1min, Current leakage 3mA

4. Remark:

Cut out 2/3 of pin3 after completing the transformer.

Appendix: User Manual (representative)

## INSTRUCTION MANUAL Bedienungsanleitung

Please keep observed safety notes before use:

Bitte lesen Sie diese Anleitung gründlich, bevor Sie das Gerät in Betrieb nehmen.

Technische Daten(Technical date): power supply

Modellbezeichnung( model): LY045-045-1000E(date code YYMM)

Eingang (input): Input: 100-240V~; 50/60Hz; 0,2 A max.

Ausgang(output): 4,5 Vdc 1000 mA

Gerät der Schutzklasse II (Class II)

Allgemeines (General)

1. For indoor use only.  
Nur zum Gebrauch in trockenen Räumen
2. The apparatus shall not be exposed to dripping or splashing and no objects filled with liquids, such as vases, shall be placed on the apparatus.  
Das Gerät darf nicht Tropf- oder Spritzwasser ausgesetzt werden und mit Flüssigkeit gefüllten Gegenstände, z. B. Vasen, dürfen nicht auf das Gerät gestellt werden.
3. Charger is Ni-MH type rechargeable batteries. Other types of batteries may burst and causing injury to persons and damage.  
Laden Sie nur aufladbare Batterien des Type Ni-MH andere Batterien Können und Verletzungen oder Schaden verursachen
4. Batteries used for 100mAh-550mAh. Do not recharge no-rechargeable batteries. Batteriearten max 100mAh-550mAh. Laden Sie nur aufladbare Batterien.
5. This appliance can be used by children aged from 8 years and above and persons with reduced physical, sensory or mental capabilities or lack of experience and knowledge if they have been given supervision or instruction concerning use of the appliance in a safe way and understand the hazards involved  
Die Steckdose muß in der Nähe der Einrichtung angebracht und leicht zugänglich sein.  
Das Gerät können von Kindern ab 8 Jahren sowie von Personen mit reduzierten physischen, sensorischen oder mentalen Fähigkeiten oder Mangel an Erfahrung und/oder Wissen benutzt werden, wenn sie beaufsichtigt oder bezüglich des sicheren Gebrauchs des Gerätes unterwiesen wurden und die daraus resultierenden Gefahren verstanden haben.
6. No playing this charger with the appliance by children  
Laden Sie nur aufladbare Batterien.
7. Before doing any cleaning or maintenance or not in use or defective the appliance must be disconnected from the power supply.

Appendix: User Manual (representative)

Soll das Gerät gereinigt oder gepflegt werden oder ist es unbenutzt oder beschädigt, muss sein Stecker erst aus der Steckdose gezogen werden.

8. Cleaning and user maintenance shall not be made by children without supervision.  
Reinigung und Benutzerwartung werden nicht von den Kindern ohne Überwachung gemacht.
9. The external flexible cable or cord of this transformer cannot be replaced; if the cord is damaged, the transformer shall be scrapped  
Die Anschlußleitung dieses Gerätes kann nicht ersetzt werden. Bei Beschädigung der Leitung ist das Gerät zu verschrotten.
10. The disconnection from line voltage is made by pulling the mains plug.  
Die Trennung vom Netz erfolgt durch Ziehen des Netzsteckers.
11. The socket outlet must be located close to the machine and be easily accessible.  
Die Steckdose muss sich in der Nähe des Gerätes befinden und leicht zugänglich sein.

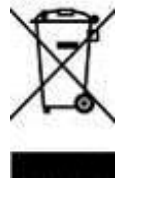
Korrekte Entsorgung dieses Produkts	
	<p>Innerhalb der EU weist dieses Symbol darauf hin, dass dieses Produkt nicht über den Hausmüll entsorgt werden darf. Altgeräte enthalten wertvolle recyclingfähige Materialien, die einer Wiederverwertung zugeführt werden sollten und um der Umwelt bzw. der menschlichen Gesundheit nicht durch unkontrollierte Müllbeseitigung zu schaden. Bitte entsorgen Sie Altgeräte deshalb über geeignete Sammelsysteme oder senden Sie das Gerät zur Entsorgung an die Stelle, bei der Sie es gekauft haben. Diese wird dann das Gerät der stofflichen Verwertung zuführen.</p>
Correct Disposal of this product	
	<p>This marking indicates that this product should not be disposed with other household wastes throughout the EU. To prevent possible harm to the environment or human health from uncontrolled waste disposal, recycle it responsibly to promote the sustainable reuse of material resources. To return your used device, please use the return and collection systems or contact the retailer where the product was purchased. They can take this product for environmental safe recycling.</p>

Manufacture name: YuYao LianYe Electronic Co., Ltd.

Address: NO.11 South Gongji Road, Linshan Town, Yuyao, Zhejiang, P. R. China

Appendix: Photos

Overview



External view of models with BS plug

Appendix: Photos



Internal view

Appendix: Photos

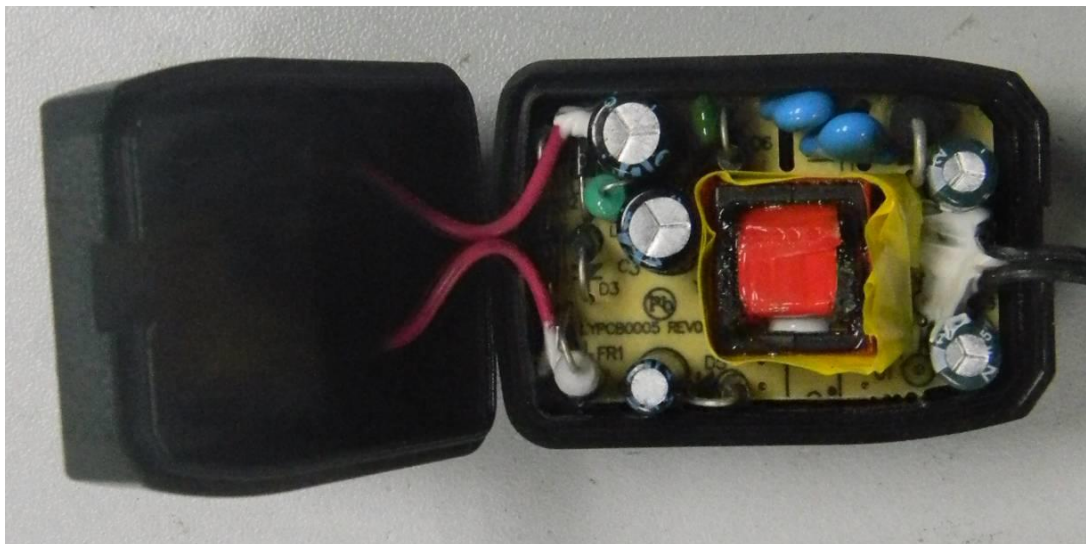
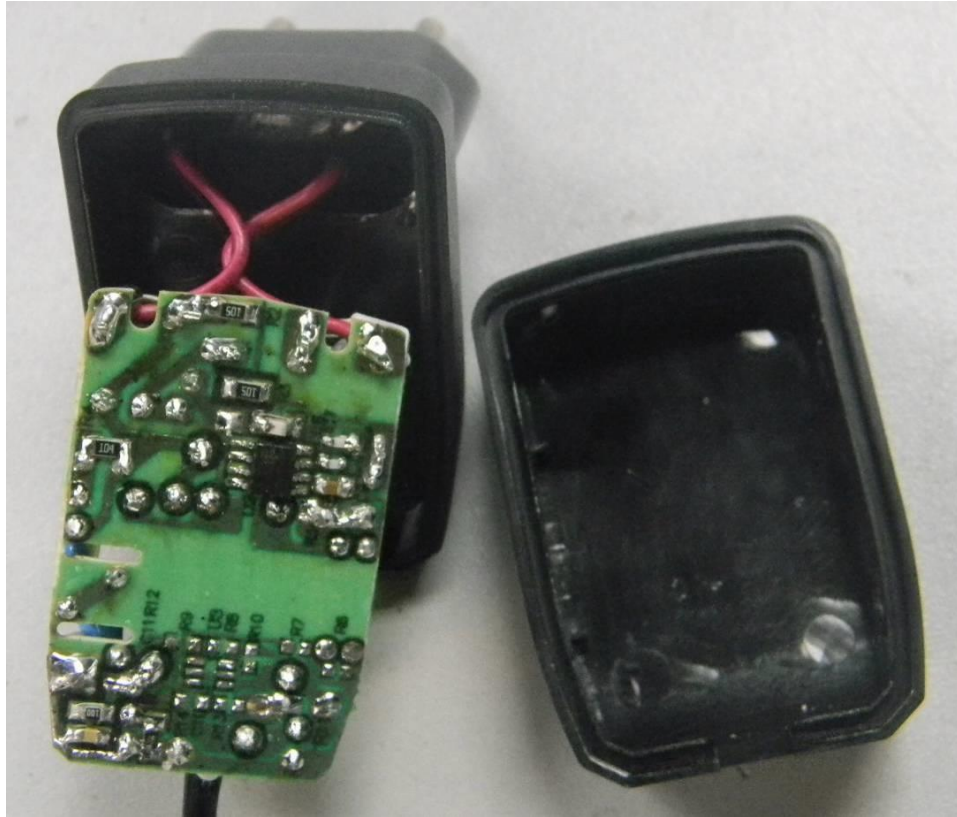

Appendix: Photos

Transformer disassembly view (representative)

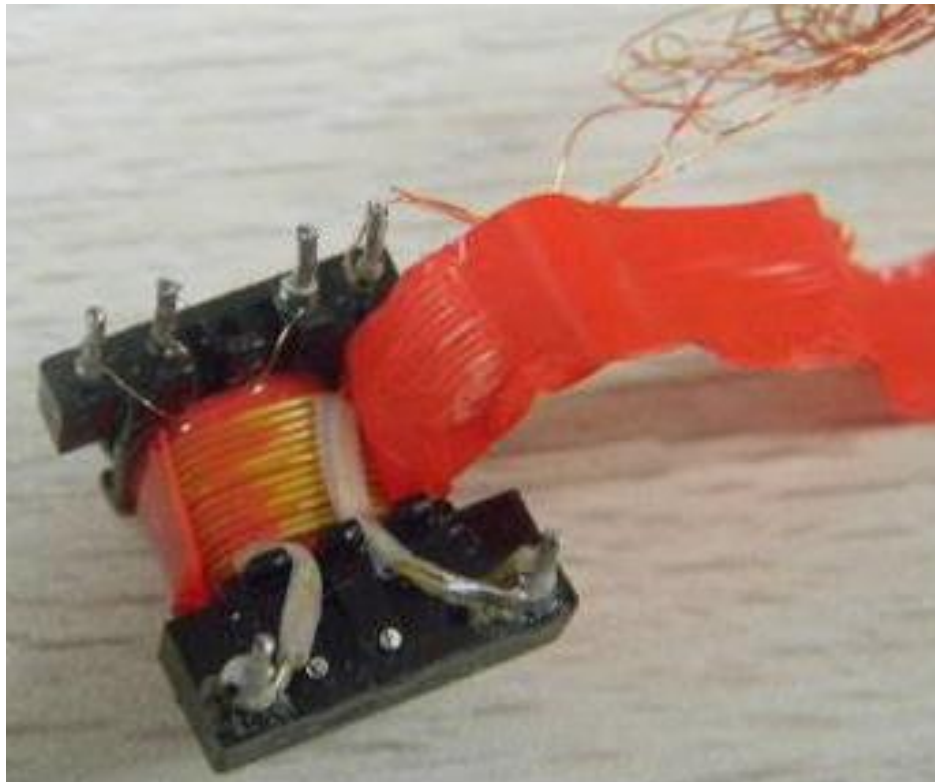

Appendix: Plug portion (EN 50075)

**Equipment's combined with two-pole plug (Class II)**

Supplementary tests on plug portion according to EN 50075 or IEC 60884-1

	Requirement - Test	References to clauses in		Result-Remark	Comply
		IEC 884-1	EN 50075		
					P
<b>1</b>	<b>Plug portion</b>				P
	CEE 7 Standard Sheet			XVI	P
	EN 50075				P
<b>2</b>	<b>Dimensions</b>				P
	Checking dimensions by measuring and by gauges according to Standard sheet				P
	The edges of the metal-pins, Chamfered or rounded off?			Rounded off	P
<b>3</b>	<b>Protection against electric shock</b>				P
<b>a</b>	Test finger (75 N, 1 min in 35°C) or Applicable appliance standard	10.1	8.1		P
<b>b</b>	Single pole insertion. Checked with gauge: Fig 4 or C19A or C19B (CEE 7)	9.2	8.2		P
<b>c</b>	Compression test 150 N, 5 min.	10.1	13.1		P
<b>d</b>	External parts made of insulating material	10.4	8.3		P
<b>4</b>	<b>Construction</b>				P
<b>a</b>	Test on pins which are not solid	14.2	9.3		N/A
<b>b</b>	Pins shall be locked against rotation 0,4 Nm 1 min.	24.2	13.2		P

Appendix: Plug portion (EN 50075)

	Requirement - Test	References to clauses in		Result-Remark	Comply
		IEC 884-1	EN 50 075		
<b>c</b>	Pins shall be adequately fixed in the body 1 min. Temperature 70°C 40 N for plugs ≤ 2,5 A 50 N for plugs > 2,5 A	24.10	13.4		P
<b>d</b>	Pins of copper or copper alloy min 58% copper or equivalent	26.5-26.6	15.3	> 58%	P
<b>e</b>	Plug shall not impose undue strain on fixed socket-outlets, 0,25 Nm	14.23.2		0,021 Nm max	P
<b>f</b>	Abrasion test on the insulating sleeves 20000 movements	24.7	13.3		P
<b>5</b>	<b>Resistance of insulating material to abnormal heat, to fire and to tracking</b>				P
<b>a</b>	Compression test 1 h in 80 °C	25.4	14.1.2		N/A
<b>b</b>	Glow-wire test 750 °C	26.1.1	17		P
<b>c</b>	Resistance to tracking 175 V (other than ordinary)	28.2			N/A
<b>EK1 557-13</b>		<b>DIN VDE 0620-2-1:2013</b>			
<b>6</b>	Tumbling barrel test	24.2		<100g for 1000 times fails, after the test according to DIN VDE 0620-2-1:2013, sub-clause 24.2, the plug was still pass the test according to DIN VDE 0620-101:1992 clause 7	P

Appendix: Plug portion (EN 50075)

**Two-pin plugs for class II appliances (Up to 2,5 A rating)**

According to EN50075 - Standard Sheet and IEC60083 - Standard C5

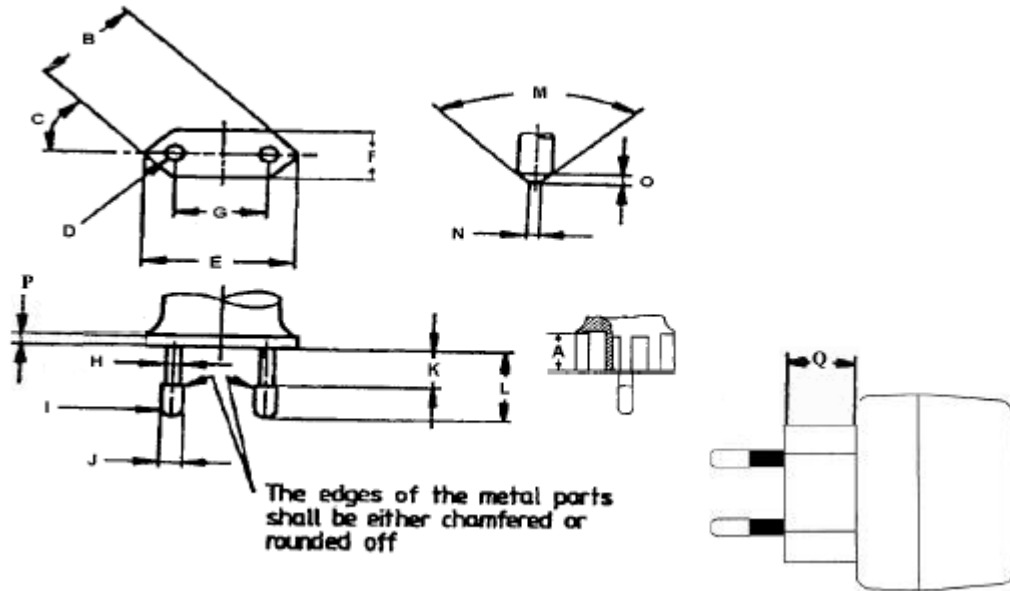

Symbol	Requirement (mm)	Measured (mm)
A	≥ 16,5	N/A
B	25,6 - 26,6	26,29-26,48
C	45 °	45 °
D	R 5,0 – 6,0	5,67
E	34,6 – 36,0	35,32-35,80
F	13,0 – 14,4	13,55-13,87
G	Engagement 18,0 – 19,2	19,04
G	End 17,0 – 18,0	17,40
H	Within 4 mm from engagement face ≤ 4,0mm	3,96
	Above 4 mm from engagement face ≤ 3,8mm	3,53

Symbol	Requirement (mm)	Measured (mm)
I	--	--
J	3,94 – 4,06	3,99
K	10,0 – 11,0	10,01
L	18,5 – 19,5	18,90
M	≤ 90 °	N/A
N	0,7 – 1,7	N/A
O	≤ 2,0	N/A
P	≥ 4,0	--
Q	≥ 18,0	18,39

Appendix: Plug portion (BS 1363-3)

Equipment combined with BS-plug

Supplementary tests on plug portion according to BS1363-3:1995 + A4:2012

Clause	Requirement - Test	Result-Remark	Comply
12.1	<b>Dimensions (Checked according to figure 4)</b>		P
12.2	<b>Outline of plug shall not exceed the dimension shown in Figure 4 for a distance of not less than 6.35 mm from the engagement surface</b>	7,35 mm	P
	<b>Pin disposition, length and body outline shall be checked by use of the gauge shown in Figure 5</b>		P
12.3	<b>L/N pin was more than 9.5 mm from the periphery of the plug measured along the engagement surface</b>	9,60 mm	P
12.7	The base and cover of rewirable plugs shall be adaptor plugs having the cover fixed by screws shall be firmly secured to each other, It shall not be possible to remove the cover unless the adaptor is completely withdrawn from the socket-outlet. Fixing screws shall be captive. The test is carried out using apparatus similar to that shown in Figure 6		N/A
12.9	After the temperature rise test (clause 16). Use test probe 11 of BS EN 61032:1998 is applied a force 30 -5/0 N. During and after the test, it was not possible to touch the live parts		P
12.11	Adaptor plug pins shall be constructed of brass, except for sleeves of pins as specified in 12.18		P
	All exposed surfaces of the adaptor plug pins shall be smooth and free from burrs or sharp edges and other irregularities which could cause damage or excessive wear to corresponding socket contacts or shutters		P
	Those surfaces of the non-solid adaptor plug pins which are visible when the adaptor is correctly assembled shall be free of apertures		N/A
	All seams and joints of non-solid adaptor plug pins shall be closed over their entire length		N/A
	For solid pins and ISODs, conformity shall be checked by 12.11.4.1	All pins are solid.	P
	For non-solid pins, compliance shall be checked by 12.11.4.2		N/A

Appendix: Plug portion (BS 1363-3)

	For ISODs, compliance shall be checked by 12.11.4.3		N/A
	Adaptors with non-solid pins and/or ISODs shall not cause excessive wear to socket contacts or shutters of socket-outlets in accordance with BS 1363-2:1995		N/A
	Adaptor plug pins shall have adequate mechanical strength to ensure that they cannot be distorted by twisting. Apply a torque 1N.m ± 10% for 60 +5/0 S. After each pin has been separately twisted, the plug was fit the gauge in fig. 5. Repeated with opposite direction		P
12.13	Adaptors shall be so designed that when fully assembled the pins are adequately retained in position such that there is no likelihood of them becoming detached from the adaptor during normal use		P
	Each pin is subjected for 60 +5/0 S to a pull of 100 -2/0 N without jerks in the direction of the major axis. The plug is mounted using the steel plate shown in fig.7. The apparatus is placed within an oven and the pull is applied at least 1 h after the plug body has attained the test temperature of 70°C ± 5°C while maintained at this temperature. After the test, the plug pin shall fit into the gauge and comply with 12.2.1		P
12.14	The degree of flexibility of mounting of the plug pins or the angular movement of the pins in the base shall be not greater than 3° 30'. See fig. 8		P
	Test procedure refers to standard. During each test, the declination from the horizontal measured on the scale was not exceed 3° 30' and comply with 12.2.1		P
12.18	Live and neutral adaptor plug pins shall be fitted with insulating sleeves. See fig.4. Sleeves shall not fitted to any earthing adaptor plug pin		P
12.19.3	Abrasion test – 10 000 times in each direction(20 000 movements) at a rate of 25 movements to 30 movements per min. (fig. 9) After the test, the sleeve shall show no damage and also shall not have been penetrated or creased, satisfy the tests in 12.19.2		P

Appendix: Plug portion (BS 1363-3)

13.10	The total mass of the equipment with all specified connectors shall not exceed 800 g. The torque exerted on a socket shall not exceed 0.7 N·m. The test apparatus as Figure 37		P
	Additional: Products with torque exceeding 0.25Nm do not comply with the main standard hence full compliance with the main standard cannot be claimed		P
Additional test for ISODs according to BS1363-3:1995 + A4:2012			
12.9.1	All exposed surfaces of plug pins shall be smooth and free from burrs or sharp edges and other irregularities which could cause damage or excessive wear to corresponding socket contacts or shutters		N/A
12.9.4	Apply a force of 400 +10/0N at a rate 10 ± 2 mm/min. Deflection shall not exceed 1.5 mm. After this test the plug should fit the gauge to fig. 5		N/A
12.9.6	ISODs shall have adequate mechanical strength to ensure that they cannot be distorted by twisting. Apply a torque 1N.m ± 10% for 60 +5/0 S. After each pin has been separately twisted, the plug shall fit the gauge in fig. 5. Repeated with opposite direction		N/A

Appendix: Plug portion (BS 1363-3)

**UK Plug Checking Form according to Figure 4 of BS1363-3**

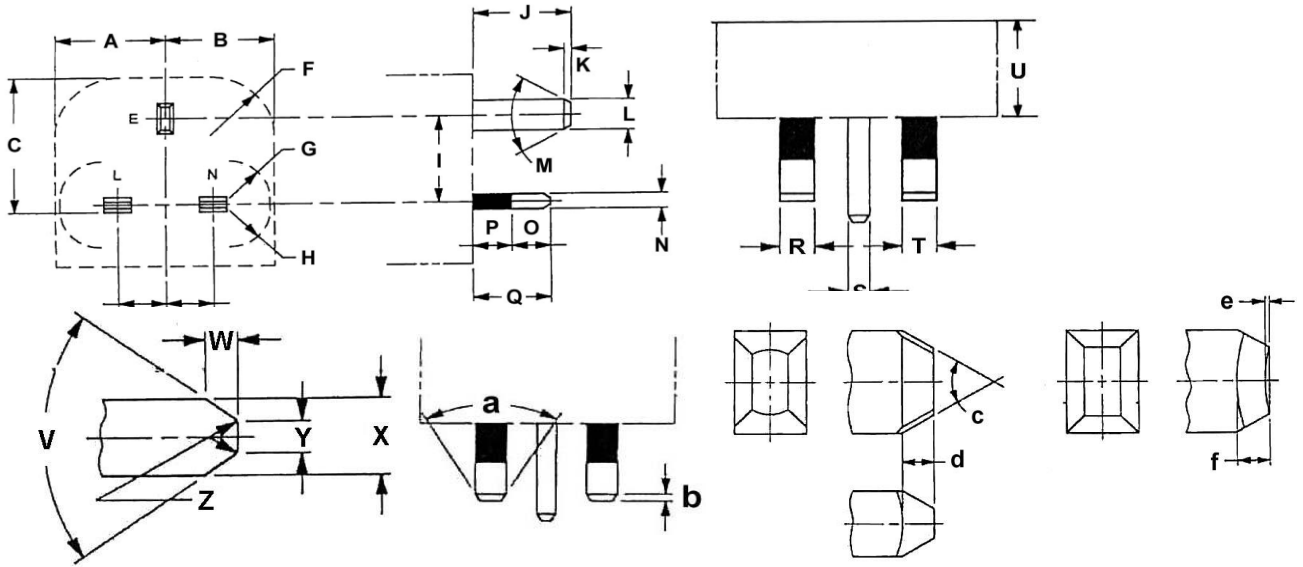

Symbol	Requirement (mm)	Measured (mm)
A	25.37 max.	23,95
B	25.37 max.	23,95
C	34.6 max.	32,80
D	11.05-11.18	11,10
E	11.05-11.18	11,10
F	R 15 min.	--
G	R 9.5 min.	9,60
H	R 9.5 min.	9,60
I	22.10-22.36	22,23
J	22.23-23.23	23,00
K	1.35-1.85	1,79
L	7.80-8.05	8,02
M	58°-62°	--
N	3.90-4.05	3,98
O	9.2 max.	8,5
P	9.5 max.	9,21

Symbol	Requirement (mm)	Measured (mm)
Q	17.2-18.2	17,71
R	6.22-6.48	6,36
S	3.90-4.05	3,97
T	6.22-6.48	6,36
U	6.35 min.	7,35
V	60°-80°	--
W	1.35-1.85	1,79
X	3.90-4.05	3,97
Y	1.2-2.0	1,52
Z	R 0.1-1.0	--
a	58°-62°	--
b	1.35-1.85	1,80
c	58°-62°	--
d	1.35-1.85	1,80
e	0.2 max.	--
f	1.35-1.85	--

Appendix : Model list

<b>MODEL</b>	<b>Output voltage (V)</b>	<b>Max current (A)</b>	<b>Max output power (W)</b>
LY045-022-YYYYE	2.2	1.2	2.64
LY045-023-YYYYE	2.3	1.2	2.76
LY045-024-YYYYE	2.4	1.2	2.88
LY045-025-YYYYE	2.5	1.2	3.00
LY045-026-YYYYE	2.6	1.2	3.12
LY045-027-YYYYE	2.7	1.2	3.24
LY045-028-YYYYE	2.8	1.2	3.36
LY045-029-YYYYE	2.9	1.2	3.48
LY045-030-YYYYE	3.0	1.2	3.60
LY045-031-YYYYE	3.1	1.1	3.41
LY045-032-YYYYE	3.2	1.1	3.52
LY045-033-YYYYE	3.3	1.1	3.63
LY045-034-YYYYE	3.4	1.0	3.40
LY045-035-YYYYE	3.5	1.0	3.50
LY045-036-YYYYE	3.6	1.0	3.60
LY045-037-YYYYE	3.7	1.0	3.70
LY045-038-YYYYE	3.8	1.0	3.80
LY045-039-YYYYE	3.9	1.0	3.90
LY045-040-YYYYE	4.0	1.0	4.00
LY045-041-YYYYE	4.1	1.0	4.10
LY045-042-YYYYE	4.2	1.0	4.20
LY045-043-YYYYE	4.3	1.0	4.30
LY045-044-YYYYE	4.4	1.0	4.40
LY045-045-YYYYE	4.5	1.0	4.50
LY045-046-YYYYE	4.6	0.8	3.68
LY045-047-YYYYE	4.7	0.8	3.76
LY045-048-YYYYE	4.8	0.8	3.84
LY045-049-YYYYE	4.9	0.8	3.92
LY045-050-YYYYE	5.0	0.8	4.00
LY045-051-YYYYE	5.1	0.7	3.57
LY045-052-YYYYE	5.2	0.7	3.64
LY045-053-YYYYE	5.3	0.7	3.71
LY045-054-YYYYE	5.4	0.7	3.78
LY045-055-YYYYE	5.5	0.7	3.85
LY045-056-YYYYE	5.6	0.7	3.92
LY045-057-YYYYE	5.7	0.7	3.99
LY045-058-YYYYE	5.8	0.7	4.06
LY045-059-YYYYE	5.9	0.7	4.13
LY045-060-YYYYE	6.0	0.6	3.60

## Appendix : Model list

<b>MODEL</b>	<b>Output voltage (V)</b>	<b>Max current (A)</b>	<b>Max output power (W)</b>
LY045-061-YYYYE	6.1	0.6	3.66
LY045-062-YYYYE	6.2	0.6	3.72
LY045-063-YYYYE	6.3	0.6	3.78
LY045-064-YYYYE	6.4	0.6	3.84
LY045-065-YYYYE	6.5	0.6	3.90
LY045-066-YYYYE	6.6	0.6	3.96
LY045-067-YYYYE	6.7	0.6	4.02
LY045-068-YYYYE	6.8	0.6	4.08