



Test Report issued under the responsibility of:

SGS Fimko Ltd.

**TEST REPORT
IEC 60335-2-25**

**Household and similar electrical appliances - Safety - Part 2-25:
Particular requirements for microwave ovens, including combination
microwave ovens**

Report Number. : GZES181100436601
Date of issue : 2018-12-12
Total number of pages..... : 120

Name of Testing Laboratory : SGS-CSTC Standards Technical Services Co., Ltd. Shunde
preparing the Report..... : Branch

Applicant's name : Guangdong Galanz Enterprise Co., Ltd.
Address : 25 Ronggui Nan Road, Shunde, Foshan, Guangdong, China

Test specification:

Standard : IEC 60335-2-25:2010, AMD1:2014, AMD2:2015 with IEC 60335-1:2010, COR1:2010, COR2:2010, AMD1:2013, COR1:2014
Test procedure..... : CB Scheme
Non-standard test method : N/A

Test Report Form No...... : IEC60335_2_25J
Test Report Form(s) Originator : LCIE
Master TRF : Dated 2018-01-26

Copyright © 2018 IEC System of Conformity Assessment Schemes for Electrotechnical Equipment and Components (IECEE System). All rights reserved.

This publication may be reproduced in whole or in part for non-commercial purposes as long as the IECEE is acknowledged as copyright owner and source of the material. IECEE takes no responsibility for and will not assume liability for damages resulting from the reader's interpretation of the reproduced material due to its placement and context.



If this Test Report Form is used by non-IECEE members, the IECEE/IEC logo and the reference to the CB Scheme procedure shall be removed.

This report is not valid as a CB Test Report unless signed by an approved CB Testing Laboratory and appended to a CB Test Certificate issued by an NCB in accordance with IECEE 02.

General disclaimer:

The test results presented in this report relate only to the object tested.
This report shall not be reproduced, except in full, without the written approval of the Issuing CB Testing Laboratory. The authenticity of this Test Report and its contents can be verified by contacting the NCB, responsible for this Test Report.

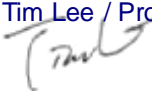







Test item description	Microwave Oven
Trade Mark.....	Galanz
Manufacturer	Guangdong Galanz Microwave Electrical Appliances Manufacturing Co., Ltd. 3 Xingpu Avenue, Huangpu, Zhongshan, Guangdong, China
Model/Type reference	P70T20(x)(y)*# (x) = L, SL, TL, P, SP, TP, AL, ASL, ATL, AP, ASP, ATP (y) = -V1, -V2, -V3, -V4, -V5, -V6, -V7, -V8; * = Blank, A, B, C, D, E, F, G, H, I, J, K, L, M, N, O, P; # = Blank, A, B, C, D, E, F, G, H, I
Ratings	230 V – 240 V; 50 Hz; 1100 W; Class I; Microwave output: 700 W, 2450 MHz

Responsible Testing Laboratory (as applicable), testing procedure and testing location(s):		
<input checked="" type="checkbox"/>	CB Testing Laboratory:	SGS-CSTC Standards Technical Services Co., Ltd. Shunde Branch
Testing location/ address..... :		Building 1, European Industrial Park, No.1, Shunhe South Road, Wusha, Daliang, Shunde District, Foshan, Guangdong, China
Tested by (name, function, signature) :		Tim Lee / Project Engineer 
Approved by (name, function, signature)... :		Vincent Chan / Reviewer 
<hr/>		
<input type="checkbox"/>	Testing procedure: CTF Stage 1:	
Testing location/ address..... :		
Tested by (name, function, signature) :		
Approved by (name, function, signature)... :		
<hr/>		
<input type="checkbox"/>	Testing procedure: CTF Stage 2:	
Testing location/ address..... :		
Tested by (name + signature)..... :		
Witnessed by (name, function, signature).. :		
Approved by (name, function, signature)... :		
<hr/>		
<input type="checkbox"/>	Testing procedure: CTF Stage 3:	
<input type="checkbox"/>	Testing procedure: CTF Stage 4:	
Testing location/ address..... :		
Tested by (name, function, signature) :		
Witnessed by (name, function, signature).. :		
Approved by (name, function, signature)... :		
Supervised by (name, function, signature) :		

<p>List of Attachments (including a total number of pages in each attachment): Attachment 1 including 6 pages of IEC 60335-1: 2010 / A2: 2016; Attachment 2 including 14 pages of EU Group Difference, national difference and EMF; Attachment 3 including 1 page of EN 60335-1: 2012 / A13: 2017; Attachment 4 including 26 pages of Photo documentation; Attachment 5 including 3 pages of Circuit diagram.</p>	
<p>Summary of testing:</p>	
<p>Tests performed (name of test and test clause): IEC 60335-2-25: 2010 + A1: 2014 + A2: 2015 IEC 60335-1: 2010 + A1: 2013 + A2: 2016 Full tests were performed on model P70T20AL-V2A and P70T20L-V1A. The submitted samples fulfil the requirements of specified standards.</p>	<p>Testing location: CBTL: SGS-CSTC Standards Technical Services Co., Ltd. Shunde Branch Building 1, European Industrial Park, No.1, Shunhe South Road, Wusha, Daliang, Shunde District, Foshan, Guangdong, China</p>
<p>Summary of compliance with National Differences (List of countries addressed): EU group difference, DE DE=Germany EK decisions according to German ProdSG have been taken into account. PAH risk evaluation according to AfPS GS 2014:01 PAK. <input checked="" type="checkbox"/> The product fulfils the requirements of EN 60335-2-25: 2012 + A1: 2015 + A2: 2016 EN 60335-1: 2012 + A11: 2014 + A13: 2017 EN 62233: 2008</p>	

Copy of marking plate:

The artwork below may be only a draft. The use of certification marks on a product must be authorized by the respective NCBS that own these marks.

<p>Galanz P70T20L-V1A MICROWAVE OVEN</p> <p>INPUT: 230-240 V 1100W (MICRO) 50Hz</p> <p>OUTPUT: 700W 2450MHz</p> <p>  </p> <p></p> <p>Guangdong Galanz Microwave Electrical Appliances Manufacturing Co., Ltd. 3 Xingpu Avenue, Huangpu, Zhongshan, Guangdong, China</p>	<p>Galanz P70T20L-V1A Mikrowellenherd</p> <p>INPUT: 230-240 V 1100W (Mikrowellen) 50Hz</p> <p>LEISTUNG: 700W 2450MHz</p> <p>  </p> <p></p> <p>Guangdong Galanz Microwave Electrical Appliances Manufacturing Co., Ltd. 3 Xingpu Avenue, Huangpu, Zhongshan, Guangdong, China</p>
------------------------------------------------------------------------------------------------------------------------------------------------------------------------------------------------------------------------------------------------------------------------------------------------------------------------------------------------------------------------------------------------------------------------------------------------------------------------------------------------------------------------------------------------------------------------------------------------------------------------------------------------------------------------------------------------------	---------------------------------------------------------------------------------------------------------------------------------------------------------------------------------------------------------------------------------------------------------------------------------------------------------------------------------------------------------------------------------------------------------------------------------------------------------------------------------------------------------------------------------------------------------------------------------------------------------------------------------------------------------------------------------------------------------------------

Remark:

The label for other model was same as above except for model number.

As declared by the applicant, the importer (and manufacturer, if it is different)'s name, registered trade name or registered trade mark and the postal address will be marked on the products before being place on the market. The contact details shall be in a language easily understood by end-users and market surveillance authorities.

Marking on the packaging or in a document accompanying the electrical equipment is only acceptable if it is not possible to place such markings on the product.

The Height of CE logo shall not be less than 5 mm; Height of WEEE logo shall not be less than 7 mm.

Test item particulars	
Classification of installation and use	Portable appliance for household and indoor use
Supply Connection.....	Non-detachable cord fitted with a plug
Possible test case verdicts:	
- test case does not apply to the test object	N/A
- test object does meet the requirement	P (Pass)
- test object does not meet the requirement	F (Fail)
Testing.....	
Date of receipt of test item	2018-11-20
Date (s) of performance of tests	2018-11-20 to 2018-12-11
General remarks:	
<p>"(See Enclosure #)" refers to additional information appended to the report. "(See appended table)" refers to a table appended to the report.</p> <p>Throughout this report a <input checked="" type="checkbox"/> comma / <input type="checkbox"/> point is used as the decimal separator.</p> <p>This document is issued by the Company subject to its General Conditions of Service, available on request or accessible at http://www.sgs.com/en/Terms-and-Conditions.aspx and, for electronic format documents, subject to Terms and Conditions for Electronic Documents at http://www.sgs.com/en/Terms-and-Conditions/Terms-e-Document.aspx. Attention is drawn to the limitation of liability, indemnification and jurisdiction issues defined therein.</p> <p>Any holder of this document is advised that information contained hereon reflects the Company's findings at the time of its intervention only and within the limits of Client's instructions, if any. The Company's sole responsibility is to its Client and this document does not exonerate parties to a transaction from exercising all their rights and obligations under the transaction documents. This document cannot be reproduced except in full, without prior written approval of the Company. Any unauthorized alteration, forgery or falsification of the content or appearance of this document is unlawful and offenders may be prosecuted to the fullest extent of the law.</p> <p>Unless otherwise stated the results shown in this test report refer only to the sample(s) tested and such sample(s) are retained for 3 months only.</p>	
Manufacturer's Declaration per sub-clause 4.2.5 of IEC 60335-1:	
The application for obtaining a CB Test Certificate includes more than one factory location and a declaration from the Manufacturer stating that the sample(s) submitted for evaluation is (are) representative of the products from each factory has been provided.....	<input type="checkbox"/> Yes <input checked="" type="checkbox"/> Not applicable
When differences exist; they shall be identified in the General product information section.	
Name and address of factory (ie s)	Same as manufacturer

General product information:

The appliances are intended to household and indoor used.

















All models are identical except for material of cavity, control type, door type, shape of knob and shape of handle, details refer to following:









Microwave mode only	Microwave output power (W)	Cavity volume: (Litre)	(x)			(y)	*	#
			Panel type	Cavity type	Door type			
P	70T: 700 W	20	Blank: Mechanical type; A: Electronic type.	S: Stainless steel; Blank: painted steel; T: Grey painted steel	L: Pull door P: Push door	Type of the appearance	Blank, A, B, C, D, E, F, G, H, I, J, K, L, M, N, O, P: shape of knob	Blank, A, B, C, D, E, F, G, H, I: shape of handle

Remark:

When 'panel type' is 'A', the '*' is blank only. When 'door type' is 'P', the '#' is blank only.

For '*' and '#' are denote the difference for shape of knob and handle, detail as below:

*= A	*= B	*= C	*= D	*= E	*= F	*= G	*= H
							
*= I	*= J	*= K	*= L	*= M	*= N	*= O	*= P
							

#= A	#= B	#= C	#= D	#= E	#= F	#= G	#= H	#= I
								

For relevant tests, see summary of testing.

IEC 60335-2-25			
Clause	Requirement - Test	Result - Remark	Verdict
5	GENERAL CONDITIONS FOR THE TESTS		--
	Tests performed according to clause 5, e.g. nature of supply, sequence of testing, etc.		P
	sequence of testing :32, 22.13, 22.108, 22.115,7 to 17, 20, 21 (except 21.101 to 21.105), 18, 19, (except 22.108, 22.113 and 22.115), 23 to 31, 21.101 to 21.105 and 19.104. (IEC 60335-2-25)		P
5.101	Microwave ovens are tested as motor-operated appliances (IEC 60335-2-25)		P
5.102	Class III temperature-sensing probes are only subjected to the tests of 22.112 (IEC 60335-2-25)		N/A
6	CLASSIFICATION		--
6.1	Protection against electric shock: Class I, II..... (IEC 60335-2-25):	Class I	P
6.2	Protection against harmful ingress of water	IPX0	N/A
7	MARKING AND INSTRUCTIONS		--
7.1	Rated voltage or voltage range (V)..... :	230 V – 240 V	P
	Symbol for nature of supply, or		N/A
	Rated frequency (Hz)..... :	50 Hz	P
	Rated power input (W), or	1100 W	P
	Rated current (A)		N/A
	Manufacturer's or responsible vendor's name, trademark or identification mark..... :	Galanz	P
	Model or type reference..... :	P70T20(x)(y)*#	P
	Symbol IEC 60417-5172, for class II appliances		N/A
	IP number, other than IPX0..... :		N/A
	Marking of rated microwave frequency (MHz) (IEC 60335-2-25)	2450 MHz	P
	Required warning "WARNING - MICROWAVE ENERGY - DO NOT REMOVE THIS COVER", for any cover, as specified (IEC 60335-2-25)		P
	Marking associated with fuses protecting socket outlet as specified (IEC 60335-2-25)		N/A
	Symbol IEC 60417-5180, for class III appliances, unless		N/A
	the appliance is operated by batteries only		N/A
	Symbol IEC 60417-5018, for class II and class III appliances incorporating a functional earth		N/A

IEC 60335-2-25			
Clause	Requirement - Test	Result - Remark	Verdict
	Symbol IEC 60417-5036, for the enclosure of electrically-operated water valves in external hose-sets for connection of an appliance to the water mains, if the working voltage exceeds extra-low voltage		N/A
7.2	Warning for stationary appliances for multiple supply		N/A
	Warning placed in vicinity of terminal cover		N/A
7.3	Range of rated values marked with the lower and upper limits separated by a hyphen		P
	Different rated values marked with the values separated by an oblique stroke		N/A
7.4	Appliances adjustable for different rated voltages or rated frequencies, the voltage or the frequency setting is clearly discernible		N/A
	Requirement met if frequent changes are not required and the rated voltage or rated frequency to which the appliance is to be adjusted is determined from a wiring diagram		N/A
7.5	Appliances with more than one rated voltage or one or more rated voltage ranges, marked with rated input or rated current for each rated voltage or range, unless		N/A
	the power input is related to the arithmetic mean value of the rated voltage range		P
	Relation between marking for upper and lower limits of rated power input or rated current and voltage is clear		N/A
7.6	Correct symbols used		P
	Symbol for nature of supply placed next to rated voltage		N/A
	Symbol for class II appliances placed unlikely to be confused with other marking		N/A
	Units of physical quantities and their symbols according to international standardized system		P
7.7	Connection diagram fixed to appliances to be connected to more than two supply conductors and appliances for multiple supply, unless		N/A
	correct mode of connection is obvious		N/A
7.8	Except for type Z attachment, terminals for connection to the supply mains indicated as follows:		--
	- marking of terminals exclusively for the neutral conductor (letter N)		N/A

IEC 60335-2-25			
Clause	Requirement - Test	Result - Remark	Verdict
	- marking of protective earthing terminals (symbol IEC 60417-5019)		P
	- marking of functional earthing terminals (symbol IEC 60417-5018)		N/A
	- marking not placed on removable parts		P
7.9	Marking or placing of switches which may cause a hazard		P
7.10	Indications of switches on stationary appliances and controls on all appliances by use of figures, letters or other visual means.....:	See photo document	P
	This applies also to switches which are part of a control		P
	If figures are used, the off position indicated by the figure 0		P
	The figure 0 indicates only OFF position, unless no confusion with the OFF position		P
7.11	Indication for direction of adjustment of controls		P
7.12	Instructions for safe use provided		P
	Details concerning precautions during user maintenance		P
	The instructions state that:		--
	- the appliance is not to be used by persons (including children) with reduced physical, sensory or mental capabilities, or lack of experience and knowledge, unless they have been given supervision or instruction		P
	- children being supervised not to play with the appliance		P
	For a part of class III construction supplied from a detachable power supply unit, the instructions state that the appliance is only to be used with the unit provided		N/A
	Instructions for class III appliances state that it must only be supplied at SELV, unless		N/A
	it is a battery-operated appliance, the battery being charged outside the appliance		N/A
	For appliances for altitudes exceeding 2000 m, the maximum altitude is stated :		N/A
	The instructions for appliances incorporating a functional earth states that the appliance incorporates an earth connection for functional purposes only		N/A

IEC 60335-2-25			
Clause	Requirement - Test	Result - Remark	Verdict
	The instructions shall state (IEC 60335-2-25):		--
	IMPORTANT SAFETY INSTRUCTIONS READ CAREFULLY AND KEEP FOR FUTURE REFERENCE		P
	WARNING: If the door seals are damaged, the oven must not be operated until it has been repaired by a trained person		P
	WARNING: It is hazardous for anyone other than a trained person to carry out any service or repair operation which involves the removal of any cover which gives protection against exposure to microwave energy		P
	WARNING: Liquids or other foods must not be heated in sealed containers since they are liable to explode		P
	This appliance is intended to be used in household and similar applications such as		--
	-staff kitchen areas in shops, offices and other working environments	Household use only	N/A
	-farm houses		N/A
	-by clients in hotels, motels and other residential environments		N/A
	-bed and breakfast type environments		N/A
	Instruction sheet includes:		P
	-The minimum height of free space necessary above the top surface of the oven	20 cm	P
	-only use utensils that are suitable for use in microwave ovens		P
	- Metallic containers for food and beverages are not allowed during microwave cooking. This requirement is not applicable if the manufacturer specifies size and shape of metallic containers suitable for microwave cooking		P
	- when heating food in plastic or paper containers, keep an eye on the oven due to the possibility of ignition		P
	-the microwave oven is intended for heating food and beverages. Drying of food or clothing and heating of warming pads, slippers, sponges, damp cloth and similar may lead to risk of injury, ignition or fire.		P
	- if smoke is observed, switch off or unplug the appliance and keep the door closed in order to stifle any flames		P
	- microwave heating of beverages can result in delayed eruptive boiling, therefore care has to be taken when handling the container;		P

IEC 60335-2-25			
Clause	Requirement - Test	Result - Remark	Verdict
	- the contents of feeding bottles and baby food jars are to be stirred or shaken and the temperature is to be checked before consumption, in order to avoid burns;		P
	- eggs in their shell and whole hard-boiled eggs shall not be heated in microwave ovens since they may explode, even after microwave heating has ended;		P
	- details for cleaning door seals, cavities and adjacent parts		P
	– The appliance shall not be cleaned with a steam cleaner.		P
	- the oven should be cleaned regularly and any food deposits removed		P
	- failure to maintain the oven in a clean condition could lead to deterioration of the surface that could adversely affect the life of the appliance and possibly result in a hazardous situation		P
	Only use the temperature probe recommended for this oven (for appliances having a facility to use a temperature-sensing probe)		N/A
	The instructions for use for fixed appliances and built-in appliances being used equal or higher than 900 mm above the floor and having detachable turntables shall state that care should be taken not to displace the turntable when removing containers from the appliance. This is not applicable for appliances with horizontal bottom hinged door.		N/A
	The manufacturer shall state in the instructions whether the microwave oven is intended to be used freestanding, built-in or in a cabinet		P
	. If the appliance can be used while placed in a cabinet, • the minimum dimensions of the cabinet shall be given by the manufacturer, and • the instructions shall state that the appliance must be operated with any cabinet door open.		N/A
	-For microwave oven having an additional decorative door, and for microwave ovens intended to be used in a cabinet, the instructions for use shall state that the microwave oven must be operated with the decorative door open.		N/A
	-For microwave ovens that are not tested in a cabinet shall state that the appliance must not be placed in a cabinet		P
	The instructions for microwave ovens that are not in compliance with 22.118 shall state that the appliance must not be installed equal or higher than 900 mm above the floor.		N/A
7.12.1	Sufficient details for installation supplied		P

IEC 60335-2-25			
Clause	Requirement - Test	Result - Remark	Verdict
	For an appliance intended to be permanently connected to the water mains and not connected by a hose-set, this is stated		N/A
	If different rated voltages or different rated frequencies are marked, the instructions state what action to be taken to adjust the appliance		N/A
7.12.2	Stationary appliances not fitted with means for disconnection from the supply mains having a contact separation in all poles that provide full disconnection under overvoltage category III, the instructions state that means for disconnection must be incorporated in the fixed wiring in accordance with the wiring rules		N/A
7.12.3	Insulation of the fixed wiring in contact with parts exceeding 50 K during clause 11; instructions state that the fixed wiring must be protected		N/A
7.12.4	Instructions for built-in appliances:		--
	- dimensions of space		N/A
	- dimensions and position of supporting and fixing		N/A
	- minimum distances between parts and surrounding structure		N/A
	- minimum dimensions of ventilating openings and arrangement		N/A
	- connection to supply mains and interconnection of separate components		N/A
	- allow disconnection of the appliance after installation, by accessible plug or a switch in the fixed wiring, unless		N/A
	a switch complying with 24.3		N/A
7.12.5	Replacement cord instructions, type X attachment with a specially prepared cord		N/A
	Replacement cord instructions, type Y attachment		P
	Replacement cord instructions, type Z attachment		N/A
7.12.6	Caution in the instructions for appliances incorporating a non-self-resetting thermal cut-out that is reset by disconnection of the supply mains, if this cut-out is required to comply with the standard		N/A
7.12.7	Instructions for fixed appliances stating how the appliance is to be fixed		P
7.12.8	Instructions for appliances connected to the water mains:		--
	- max. inlet water pressure (Pa).....:		N/A
	- min. inlet water pressure, if necessary (Pa):		N/A

IEC 60335-2-25			
Clause	Requirement - Test	Result - Remark	Verdict
	Instructions concerning new and old hose-sets for appliances connected to the water mains by detachable hose-sets		N/A
7.13	Instructions and other texts in an official language	English and German	P
7.14	Marking clearly legible and durable, rubbing test as specified		P
	Height of the lettering of the warning specified in 7.1 is at least 3 mm. (IEC 60335-2-25)		P
7.15	Markings on a main part		P
	Marking clearly discernible from the outside, if necessary after removal of a cover		P
	For portable appliances, cover can be removed or opened without a tool		N/A
	For stationary appliances, name, trademark or identification mark and model or type reference visible after installation		N/A
	For fixed appliances, name, trademark or identification mark and model or type reference visible after installation according to the instructions		N/A
	Indications for switches and controls placed on or near the components. Marking not on parts which can be positioned or repositioned in such a way that the marking is misleading		P
	The symbol IEC 60417-5018 placed next to the symbol IEC 60417-5172 or IEC 60417-5180		N/A
7.16	Marking of a possible replaceable thermal link or fuse link clearly visible with regard to replacing the link		N/A
8	PROTECTION AGAINST ACCESS TO LIVE PARTS		--
8.1	Adequate protection against accidental contact with live parts		P
8.1.1	Requirement applies for all positions, detachable parts removed		P
	Lamps behind a detachable cover not removed, if conditions met		N/A
	Insertion or removal of lamps, protection against contact with live parts of the lamp cap		N/A
	Use of test probe B of IEC 61032, with a force not exceeding 1 N: no contact with live parts		P

IEC 60335-2-25			
Clause	Requirement - Test	Result - Remark	Verdict
	Use of Test probe 18 of IEC 61032 applied to parts that are accessible when the oven is operated in normal use: no contact with live parts (IEC 60335-2-25)		P
8.1.2	Use of test probe 13 of IEC 61032, with a force not exceeding 1 N, through openings in class 0 appliances and class II appliances/constructions: no contact with live parts		P
	Test probe 13 also applied through openings in earthed metal enclosures having a non-conductive coating: no contact with live parts		P
8.1.3	For appliances other than class II, use of test probe 41 of IEC 61032, with a force not exceeding 1 N: no contact with live parts of visible glowing heating elements		N/A
8.1.4	Accessible part not considered live if:		--
	- safety extra-low a.c. voltage: peak value not exceeding 42.4 V		N/A
	- safety extra-low d.c. voltage: not exceeding 42.4 V	12,5 V	P
	- or separated from live parts by protective impedance		N/A
	If protective impedance: d.c. current not exceeding 2 mA, and		N/A
	a.c. peak value not exceeding 0.7 mA		N/A
	- for peak values over 42.4 V up to and including 450 V, capacitance not exceeding 0,1 μ F		N/A
	- for peak values over 450 V up to and including 15 kV, discharge not exceeding 45 μ C		N/A
	- for peak values over 15kV, the energy in the discharge not exceeding 350 mJ		N/A
8.1.5	Live parts protected at least by basic insulation before installation or assembly:		--
	- built-in appliances		N/A
	- fixed appliances		N/A
	- appliances delivered in separate units		N/A
8.2	Class II appliances and constructions constructed so that there is adequate protection against accidental contact with basic insulation and metal parts separated from live parts by basic insulation only		P
	Only possible to touch parts separated from live parts by double or reinforced insulation		P

IEC 60335-2-25			
Clause	Requirement - Test	Result - Remark	Verdict
	Use of Test probe 18 of IEC 61032 applied to parts that are accessible when the oven is operated in normal use (IEC 60335-2-25)		P
9	STARTING OF MOTOR-OPERATED APPLIANCES		--
	Requirements and tests are specified in part 2 when necessary		N/A
10	POWER INPUT AND CURRENT		--
10.1	Power input at normal operating temperature, rated voltage and normal operation not deviating from rated power input by more than shown in table 1 ..:	(see appended table)	P
	If the power input varies throughout the operating cycle and the maximum value of the power input exceeds, by a factor greater than two, the arithmetic mean value of the power input occurring during a representative period, the power input is the maximum value that is exceeded for more than 10 % of the representative period		N/A
	Otherwise the power input is the arithmetic mean value		N/A
	Test carried out at upper and lower limits of the ranges for appliances with one or more rated voltage ranges, unless		N/A
	the rated power input is related to the arithmetic mean value		P
10.2	Current at normal operating temperature, rated voltage and normal operation not deviating from rated current by more than shown in table 2		N/A
	If the current varies throughout the operating cycle and the maximum value of the current exceeds, by a factor greater than two, the arithmetic mean value of the current occurring during a representative period, the current is the maximum value that is exceeded for more than 10 % of the representative period		N/A
	Otherwise the current is the arithmetic mean value		N/A
	Test carried out at upper and lower limits of the ranges for appliances with one or more rated voltage ranges, unless		N/A
	the rated current is related to the arithmetic mean value of the range		N/A
11	HEATING		--
11.1	No excessive temperatures in normal use		P
11.2	The appliance is held, placed or fixed in position as described	Placed on table	P

IEC 60335-2-25			
Clause	Requirement - Test	Result - Remark	Verdict
	Placing and mounting of appliance in the test corner (as specified for heating appliances) (IEC 60335-2-25)	Placed on the floor as near to the walls as possible	P
	Height of ceiling : (IEC 60335-2-25)	20 cm	P
11.3	Temperature rises, other than of windings, determined by thermocouples		P
	Temperature rises of windings determined by resistance method, unless	Fan motor winidng, turntable motor winding, H,V, transformer winidng	P
	the windings are non-uniform or it is difficult to make the necessary connections	H,F, transformer winding	P
11.4	Heating appliances operated under normal operation at 1.15 times rated power input (W)		N/A
11.5	Motor-operated appliances operated under normal operation at most unfavourable voltage between 0.94 and 1.06 times rated voltage (V).....	1,06 x 240 V = 254,4 V	P
11.6	Combined appliances operated under normal operation at most unfavourable voltage between 0.94 and 1.06 times rated voltage (V).....		N/A
11.7	Appliances are operated for three cycles (heating period of 10mn) separated by a 1 min rest period (IEC 60335-2-25)		P
11.8	Temperature rises monitored continuously and not exceeding the values in table 3	(see appended table)	P
	If the temperature rise of a motor winding exceeds the value of table 3, or		N/A
	if there is doubt with regard to classification of insulation,		N/A
	tests of Annex C are carried out		N/A
	Sealing compound does not flow out		P
	Protective devices do not operate, except		P
	components in protective electronic circuits tested for the number of cycles specified in 24.1.4		N/A
	The temperature rises of external surfaces are only measured on the surfaces that are not placed against the wall and the floor of the test corner (IEC 60335-2-25)		P
	No temperature rise limits for air-outlet grilles and for surfaces up to a distance of 25mm from them (IEC 60335-2-25)		P
13	LEAKAGE CURRENT AND ELECTRIC STRENGTH AT OPERATING TEMPERATURE		--

IEC 60335-2-25			
Clause	Requirement - Test	Result - Remark	Verdict
13.1	Leakage current not excessive and electric strength adequate		P
	Heating appliances operated at 1.15 times the rated power input (W)		N/A
	Motor-operated appliances and combined appliances supplied at 1.06 times the rated voltage (V)	1,06 x 240 V = 254,4 V	P
	Protective impedance and radio interference filters disconnected before carrying out the tests		P
13.2	For class 0, class II and class III appliances, and class II constructions, leakage current measured by means of the circuit described in figure 4 of IEC 60990		P
	For class 0I and class I appliances, a low impedance ammeter may be used		P
	Leakage current measurements	(see appended table)	P
13.3	The appliance is disconnected from the supply		P
	Electric strength tests according to table 4.....	(see appended table)	P
	No breakdown during the tests		P
14	TRANSIENT OVERVOLTAGES		--
	Appliances withstand the transient over-voltages to which they may be subjected		N/A
	Clearances having a value less than specified in table 16 subjected to an impulse voltage test, the test voltage specified in table 6.....		N/A
	No flashover during the test, unless		N/A
	of functional insulation if the appliance complies with clause 19 with the clearance short-circuited		N/A
15	MOISTURE RESISTANCE		--
15.1	Enclosure provides the degree of moisture protection according to classification of the appliance	IPX0	P
	Compliance checked as specified in 15.1.1, taking into account 15.1.2, followed by the electric strength test of 16.3		N/A
	No trace of water on insulation which can result in a reduction of clearances or creepage distances below values specified in clause 29		N/A
15.1.1	Appliances, other than IPX0, subjected to tests as specified in IEC 60529.....		N/A

IEC 60335-2-25			
Clause	Requirement - Test	Result - Remark	Verdict
	Water valves containing live parts in external hoses for connection of an appliance to the water mains tested as specified for IPX7 appliances		N/A
15.1.2	Hand-held appliance turned continuously through the most unfavourable positions during the test		N/A
	Built-in appliances installed according to the instructions		N/A
	Appliances placed or used on the floor or table placed on a horizontal unperforated support		N/A
	Appliances normally fixed to a wall and appliances with pins for insertion into socket-outlets are mounted on a wooden board		N/A
	For IPX3 appliances, the base of wall mounted appliances is placed at the same level as the pivot axis of the oscillating tube		N/A
	For IPX4 appliances, the horizontal centre line of the appliance is aligned with the pivot axis of the oscillating tube, and		N/A
	for appliances normally used on the floor or table, the movement is limited to two times 90° for a period of 5 min, the support being placed at the level of the pivot axis of the oscillating tube		N/A
	Wall-mounted appliances, take into account the distance to the floor stated in the instructions		N/A
	Appliances normally fixed to a ceiling are mounted underneath a horizontal unperforated support, the pivot axis of the oscillating tube located at the level of the underside of the support, and		N/A
	for IPX4 appliances, the movement of the tube is limited to two times 90° from the vertical for a period of 5 min		N/A
	Appliances with type X attachment fitted with a flexible cord as described		N/A
	Detachable parts subjected to the relevant treatment with the main part		N/A
	However, if a part has to be removed for user maintenance and a tool is needed, this part is not removed		N/A
15.2	Spillage of liquid does not affect the electrical insulation		P
	Spillage solution comprising water containing approximately 1 % NaCl and 0,6 % rinsing agent		P
	Appliances with type X attachment fitted with a flexible cord as described		N/A

IEC 60335-2-25			
Clause	Requirement - Test	Result - Remark	Verdict
	Appliances incorporating an appliance inlet tested with or without an connector, whichever is most unfavourable		N/A
	Detachable parts are removed		P
	Overfilling test with additional amount of water, over a period of 1 min (l)		N/A
	Overfilling test (0,5l of salt water with 1%NaCl) (IEC 60335-2-25)		P
	The appliance withstands the electric strength test of 16.3		P
	No trace of water on insulation that can result in a reduction of clearances or creepage distances below values specified in clause 29		P
15.3	Appliances proof against humid conditions		P
	Checked by test Cab: Damp heat steady state in IEC 60068-2-78		P
	Detachable parts removed and subjected, if necessary, to the humidity test with the main part		P
	Humidity test for 48 h in a humidity cabinet	25 °C, 93% R.H.	P
	Reassembly of those parts that may have been removed		P
	The appliance withstands the tests of clause 16		P
15.101	Water does not affect the electrical insulation of temperature sensing probes: test according as specified. (IEC 60335-2-25)		N/A
	Withstand test of 16.2 after test specified		N/A
15.102	Microwave ovens intended to be built-in as under-bench installation and therefore subject to spillage of liquid from containers onto working surfaces shall be constructed so that such spillage does not affect their electrical insulation (IEC 60335-2-25)		N/A
	The appliance shall withstand the electric strength test of 16.3, and no trace of water on insulation that could result in a reduction of clearances or creepage distances below the values specified in Clause 29		N/A
15.103	Microwave ovens intended to be built-in in cabinets underneath other built-in appliances and therefore subject to spillage of liquid from filled containers which are handled during usage of these other appliances shall be constructed so that such spillage does not affect their electrical insulation (IEC 60335-2-25)		N/A

IEC 60335-2-25			
Clause	Requirement - Test	Result - Remark	Verdict
	The appliance shall withstand the electric strength test of 16.3, and no trace of water on insulation that could result in a reduction of clearances or creepage distances below the values specified in Clause 29		N/A
16	LEAKAGE CURRENT AND ELECTRIC STRENGTH		--
16.1	Leakage current not excessive and electric strength adequate		P
	Protective impedance disconnected from live parts before carrying out the tests		N/A
	Tests carried out at room temperature and not connected to the supply		P
16.2	Single-phase appliances: test voltage 1.06 times rated voltage (V).....:	1,06 x 240 V = 254,4 V	P
	Three-phase appliances: test voltage 1.06 times rated voltage divided by $\sqrt{3}$ (V)		N/A
	Leakage current measurements.....:	(see appended table)	P
	Limit values doubled if:		--
	- all controls have an off position in all poles, or		N/A
	- the appliance has no control other than a thermal cut-out, or		N/A
	- all thermostats, temperature limiters and energy regulators do not have an off position, or		N/A
	- the appliance has radio interference filters		P
	With the radio interference filters disconnected, the leakage current do not exceed limits specified	(see appended table)	P
16.3	Electric strength tests according to table 7.....:	(see appended table)	P
	Test voltage applied between the supply cord and inlet bushing and cord guard and cord anchorage as specified	(see appended table)	P
	No breakdown during the tests		P
16.101	Insulation of power transformer (IEC 60335-2-25)		P
16.101.1	Transformer subjected for 1 min to a substantially 50 Hz or 60 Hz sinusoidal waveform voltage of Value:		N/A
	no flashover or breakdown occurs		N/A
16.101.2	Test for transformers other than switch-mode type		P
	- frequency (Hz) :	400 Hz	P
	- duration (s) :	15 s	P
	- test voltage (V) :	476,3 V	P
	no flashover or breakdown occurs		P

IEC 60335-2-25			
Clause	Requirement - Test	Result - Remark	Verdict
17	OVERLOAD PROTECTION OF TRANSFORMERS AND ASSOCIATED CIRCUITS		--
	No excessive temperatures in transformer or associated circuits in event of short-circuits likely to occur in normal use	(See appended table)	P
	Appliance supplied with 1.06 or 0.94 times rated voltage under the most unfavourable short-circuit or overload likely to occur in normal use (V)	254,4 V	P
	Basic insulation is not short-circuited		P
	Temperature rise of insulation of the conductors of safety extra-low voltage circuits not exceeding the relevant value specified in table 3 by more than 15 K		P
	Temperature of the winding not exceeding the value specified in table 8		N/A
	However, limits do not apply to fail-safe transformers complying with sub-clause 15.5 of IEC 61558-1		P
	The tests are not carried out on the power transformer that supplies the magnetron and its associated circuits, these being checked during the tests of clause 19 (IEC 60335-2-25)		N/A
18	ENDURANCE		--
	Requirements and tests are specified in part 2 when necessary	8,3 W/m ² (limit 50 W/m ²)	P
19	ABNORMAL OPERATION		--
19.1	The risk of fire, mechanical damage or electric shock under abnormal or careless operation obviated		P
	Electronic circuits so designed and applied that a fault will not render the appliance unsafe		P
	Instead of subjecting the appliance to the tests of 19.2 to 19.10, compliance is checked by the tests of 19.101 to 19.104, the appliance being supply at rated voltage (IEC 60335-2-25)		P
	Appliances incorporating electronic circuits subjected to the tests of 19.11 and 19.12, as applicable		P
	Appliances incorporating contactors or relays subjected to the test of 19.14, being carried out before the tests of 19.11		N/A
	Appliances incorporating voltage selector switches subjected to the test of 19.15		N/A

IEC 60335-2-25			
Clause	Requirement - Test	Result - Remark	Verdict
	Unless otherwise specified, the tests are continued until a non-self-resetting thermal cut-out operates, or		P
	until steady conditions are established		P
	If a heating element or intentionally weak part becomes open-circuited, the relevant test is repeated on a second sample		N/A
19.7	Stalling test by locking the rotor if the locked rotor torque is smaller than the full load torque, or		N/A
	locking moving parts of other appliances		N/A
	Locked rotor, capacitors open-circuited one at a time		N/A
	Test repeated with capacitors short-circuited one at a time, unless		N/A
	the capacitor is of class P2 of IEC 60252-1		N/A
	Appliances with timer or programmer supplied with rated voltage for each of the tests, for a period equal to the maximum period allowed :		N/A
	An electronic timer or programmer that operates to ensure compliance with the test before the maximum period under the conditions of Clause 11 is reached, is a protective electronic circuit		N/A
	Other appliances supplied with rated voltage for a period as specified :		N/A
	Winding temperatures not exceeding values specified in table 8 :		N/A
19.8	Multi-phase motors operated at rated voltage with one phase disconnected		N/A
19.9	Running overload test on appliances incorporating motors intended to be remotely or automatically controlled or liable to be operated continuously		N/A
	Motor-operated and combined appliances for which 30.2.3 is applicable and that use overload protective devices relying on electronic circuits to protect the motor windings, are also subjected to the test		N/A
	Winding temperatures not exceeding values as specified :		N/A
19.10	Series motor operated at 1.3 times rated voltage for 1 min (V) :		N/A
	During the test, parts not being ejected from the appliance		N/A

IEC 60335-2-25			
Clause	Requirement - Test	Result - Remark	Verdict
19.11	Electronic circuits, compliance checked by evaluation of the fault conditions specified in 19.11.2 for all circuits or parts of circuits, unless		P
	they comply with the conditions specified in 19.11.1		N/A
	Appliances incorporating an electronic circuit that relies upon a programmable component to function correctly, subjected to the test of 19.11.4.8, unless		N/A
	restarting does not result in a hazard		P
	Appliances having a device with an off position obtained by electronic disconnection, or a device placing the appliance in a stand-by mode, subjected to the tests of 19.11.4		N/A
	If the safety of the appliance under any of the fault conditions depends on the operation of a miniature fuse-link complying with IEC 60127, the test of 19.12 is carried out		P
	During and after each test the following is checked:		--
	- the temperature of the windings do not exceed the values specified in table 8		P
	- the appliance complies with the conditions specified in 19.13		P
	- any current flowing through protective impedance not exceeding the limits specified in 8.1.4		N/A
	If a conductor of a printed board becomes open-circuited, the appliance is considered to have withstood the particular test, provided both of the following conditions are met:		--
	- the base material of the printed circuit board withstands the test of Annex E		P
	- any loosened conductor does not reduce clearance or creepage distances between live parts and accessible metal parts below the values specified in clause 29		P
19.11.1	Fault conditions a) to g) in 19.11.2 are not applied to circuits or parts of circuits meeting both of the following conditions:		--
	- the electronic circuit is a low-power circuit, that is, the maximum power at low-power points does not exceed 15 W according to the tests specified		N/A
	- the protection against electric shock, fire hazard, mechanical hazard or dangerous malfunction of other parts of the appliance does not rely on the correct functioning of the electronic circuit		N/A
19.11.2	Fault conditions applied one at a time, the appliance operating under conditions specified in clause 11, but supplied at rated voltage, duration of the tests as specified:		--

IEC 60335-2-25			
Clause	Requirement - Test	Result - Remark	Verdict
	a) short circuit of functional insulation if clearances or creepage distances are less than the values specified in clause 29		P
	b) open circuit at the terminals of any component	(See appended table)	P
	c) short circuit of capacitors, unless	(See appended table)	P
	they comply with IEC 60384-14	(See appended table)	P
	d) short circuit of any two terminals of an electronic component, other than integrated circuits	(See appended table)	P
	This fault condition is not applied between the two circuits of an optocoupler	(See appended table)	P
	e) failure of triacs in the diode mode		N/A
	f) failure of microprocessors and integrated circuits		N/A
	g) failure of an electronic power switching device		N/A
	Each low power circuit is short-circuited by connecting the low-power point to the pole of the supply source from which the measurements were made		N/A
	cathode-to-anode circuit of the magnetron is open-circuited and short-circuited in turn, with appliance supplied at : (IEC 60335-2-25)	Filament of the magnetron is not short-circuited	P
19.11.3	If the appliance incorporates a protective electronic circuit which operates to ensure compliance with clause 19, the relevant test is repeated with a single fault simulated, as indicated in a) to g) of 19.11.2		N/A
19.11.4	Appliances having a device with an off position obtained by electronic disconnection, or		N/A
	a device that can be placed in the stand-by mode,		N/A
	subjected to the tests of 19.11.4.1 to 19.11.4.7, the device being set in the off position or in the stand-by mode		N/A
	Appliances incorporating a protective electronic circuit subjected to the tests of 19.11.4.1 to 19.11.4.7, the tests being carried out after the protective electronic circuit has operated, except that		N/A
	appliances operated for 30 s or 5 min during the test of 19.7 are not subjected to the tests for electromagnetic phenomena.		N/A
	Surge protective devices disconnected, unless		N/A
	They incorporate spark gaps		N/A

IEC 60335-2-25			
Clause	Requirement - Test	Result - Remark	Verdict
19.11.4.1	The appliance is subjected to electrostatic discharges in accordance with IEC 61000-4-2, test level 4		N/A
19.11.4.2	The appliance is subjected to radiated fields in accordance with IEC 61000-4-3, test level 3		N/A
19.11.4.3	The appliance is subjected to fast transient bursts in accordance with IEC 61000-4-4, test level 3 or 4 as specified		N/A
19.11.4.4	The power supply terminals of the appliance subjected to voltage surges in accordance with IEC 61000-4-5, test level 3 or 4 as specified		N/A
	An open circuit test voltage of 2 kV is applicable for the line-to-line coupling mode		N/A
	An open circuit test voltage of 4 kV is applicable for the line-to-earth coupling		N/A
	Earthed heating elements in class I appliances disconnected		N/A
19.11.4.5	The appliance is subjected to injected currents in accordance with IEC 61000-4-6, test level 3		N/A
19.11.4.6	Appliances having a rated current not exceeding 16 A are subjected to the Class 3 voltage dips and interruptions in accordance with IEC 61000-4-11		N/A
	Appliances having a rated current exceeding 16 A are subjected to the Class 3 voltage dips and interruptions in accordance with IEC 61000-4-34		N/A
19.11.4.7	The appliance is subjected to mains signals in accordance with IEC 61000-4-13, test level class 2		N/A
19.11.4.8	The appliance is supplied at rated voltage and operated under normal operation. After 60s the power supply is reduced to a level such that the appliance ceases to respond or parts controlled by the programmable component cease to operate		N/A
	The appliance continues to operate normally, or		N/A
	requires a manual operation to restart		N/A
19.12	If the safety of the appliance for any of the fault conditions specified in 19.11.2 depends on the operation of a miniature fuse-link complying with IEC 60127, the test is repeated, measuring the current flowing through the fuse-link; measured current (A); rated current of the fuse-link (A).....:	Fuse link: Rated current: 8 A Measured current: 32 A H,V fuse: Rated current: 0,65 A Measured current: 4 A	P
19.13	During the tests the appliance does not emit flames, molten metal, poisonous or ignitable gas in hazardous amounts		P

IEC 60335-2-25			
Clause	Requirement - Test	Result - Remark	Verdict
	Temperature rises not exceeding the values shown in table 9.....:	(see appended table)	P
	Compliance with clause 8 not impaired		P
	If the appliance can still be operated it complies with 20.2		P
	Insulation, other than of class III appliances or class III constructions that do not contain live parts, withstands the electric strength test of 16.3, the test voltage as specified in table 4:		--
	- basic insulation (V)	1000 V	P
	- supplementary insulation (V)		N/A
	- reinforced insulation (V)	3000 V	P
	After operation or interruption of a control, clearances and creepage distances across the functional insulation withstand the electric strength test of 16.3, the test voltage being twice the working voltage		P
	The appliance does not undergo a dangerous malfunction, and		P
	no failure of protective electronic circuits, if the appliance is still operable		N/A
	Appliances tested with an electronic switch in the off position, or in the stand-by mode:		--
	- do not become operational, or		P
	- if they become operational, do not result in a dangerous malfunction during or after the tests of 19.11.4		N/A
	If the appliance contains lids or doors that are controlled by one or more interlocks, one of the interlocks may be released provided that:		--
	- the lid or door does not move automatically to an open position when the interlock is released, and		N/A
	- the appliance does not start after the cycle in which the interlock was released		N/A
	the temperature of windings not exceeding the values specified in Table 8. Only appliances that allow pre-selected start time and those operating with a keep-warm function are considered to be appliances operated until steady conditions established (IEC 60335-2-25)		P
	During the test the microwave leakage shall not exceed 100W/m ² measured in accordance with clause 32 but with the load specified for each subclause (IEC 60335-2-25)	2,6 W/m ²	P

IEC 60335-2-25			
Clause	Requirement - Test	Result - Remark	Verdict
	The appliance shall comply with clause 32 after the tests. (IEC 60335-2-25)	2,9 W/m ²	P
19.14	Appliances operated under the conditions of clause 11, any contactor or relay contact operating under the conditions of clause 11 being short-circuited		P
	For a relay or contactor with more than one contact, all contacts are short-circuited at the same time		P
	A relay or contactor operating only to ensure the appliance is energized for normal use is not short-circuited		N/A
	If more than one relay or contactor operates in clause 11, they are short-circuited in turn		P
19.15	For appliances with a mains voltage selector switch, the switch is set to the lowest rated voltage position and the highest value of rated voltage is applied		N/A
19.101	Appliance operated at highest power level without load in the cavity (IEC 60335-2-25)		P
	- Test duration		P
19.102	Test with normal operation; timer and controls made inoperative (IEC 60335-2-25)		P
19.103	Fault simulation of components: (IEC 60335-2-25)		P
	- blocking of air opening in the same plane (not applied for a built-in appliance)		P
	- locking of rotor of motor (if the locked motor torque is smaller than the full load torque)		P
	- locking of moving parts		P
19.104	Possible fire occurring in the cavity contained within the appliance (max. microwave power, most unfavourable settings, potato load as specified, 15min duration) (IEC 60335-2-25)		P
	Compliance with 19.13 if the appliance is still operable after the test		P
	Test repeated on a second oven		N/A
19.105	Built-in appliances having an additional decorative door, and/or appliances to be used in a cabinet, are operated under normal operation but with the decorative door or cabinet door closed (IEC 60335-2-25)		N/A
20	STABILITY AND MECHANICAL HAZARDS		--
20.1	Appliances having adequate stability		P

IEC 60335-2-25			
Clause	Requirement - Test	Result - Remark	Verdict
	Tilting test through an angle of 10°, appliance placed on an inclined plane/horizontal support, not connected to the supply mains; appliance does not overturn		P
	Tilting test repeated on appliances with heating elements, angle of inclination increased to 15°		N/A
	Possible heating test in overturned position; temperature rise does not exceed values shown in table 9		N/A
20.2	Moving parts adequately arranged or enclosed as to provide protection against personal injury		P
	Protective enclosures, guards and similar parts are non-detachable, and		P
	have adequate mechanical strength		P
	Enclosures that can be opened by overriding an interlock are considered to be detachable parts		P
	Self-resetting thermal cut-outs and overcurrent protective devices not causing a hazard by unexpected closure		P
	Not possible to touch dangerous moving parts with the test probe described		P
20.101	For appliances other than built-in appliances (bottom-hinged doors): (IEC 60335-2-25)	Sid-hinged doors	N/A
	- 7 kg for stationary appliances: no tilt		N/A
	- 3,5 kg for portable appliances: no tilt		N/A
21	MECHANICAL STRENGTH		--
21.1	Appliance has adequate mechanical strength and is constructed as to withstand rough handling		P
	Checked by applying 3 blows to every point of the enclosure like to be weak, in accordance with test Ebb of IEC 60068-2-75, spring hammer test, with an impact energy of 0,5 J		P
	The appliance shows no damage impairing compliance with this standard, and		P
	compliance with 8.1, 15.1 and clause 29 not impaired		P
	If doubt, supplementary or reinforced insulation subjected to the electric strength test of 16.3		N/A
	If necessary, repetition of groups of three blows on a new sample		N/A
21.2	Accessible parts of solid insulation having strength to prevent penetration by sharp implements		P

IEC 60335-2-25			
Clause	Requirement - Test	Result - Remark	Verdict
	Test not applicable if the thickness of supplementary insulation is at least 1 mm and reinforced insulation at least 2 mm	See table 29.3	P
	The insulation is tested as specified, and does withstand the electric strength test of 16.3		N/A
21.101	Operating of the door, as specified spring balance with spring constant of 1,05N/mm: (IEC 60335-2-25)		--
	- opening operation: 5times; force of 35N		P
	- opening operation for stationary ovens and ovens for building-in: 5times; force of 1,5times the force to open the door or 65N, whichever is the greater. Force:		P
	- closing operation: 10times; force of 90N		P
	Test according to 32	0,8 W/m ² (limit: 50 W/m ²)	P
21.102	Hinged door test, as specified (IEC 60335-2-25)		--
	Side-hinged door: 5times; applied force (N): max. 140N :		P
	Bottom-hinged door: 15min; applied force (N): max. 140N :		N/A
	Test according to 32	1,1 W/m ² (limit: 50 W/m ²)	P
21.103	Hinged door: wooden cube test on each corner as specified (force of 90N for 5s) (IEC 60335-2-25)		--
	Test according to 32	0,9 W/m ² (limit: 50 W/m ²)	P
21.104	Steel ball test of cavity door, as specified (steel ball of 50mm diameter and 0,5kg) (IEC 60335-2-25)		P
	3impacts outside, inside and on the seal surface		P
	Bottom-hinged door: 3 more impacts on door seal		N/A
	A bottom-hinged door is further tested by subjecting its seal to three similar impacts		N/A
	Test according to 32	1,3 W/m ² (limit: 50 W/m ²)	P
21.105	Dowel test of bottom-hinged door, as specified (hardwood dowel) of diameter 10mm and 300mm length, 90N for 5s, test made with dowel on each side and at the centre of bottom edge) (IEC 60335-2-25)	Side-hinged door	N/A
	Microwave leakage measurement: energy flux density not exceed 100W/m ²		N/A
22	CONSTRUCTION		--

IEC 60335-2-25			
Clause	Requirement - Test	Result - Remark	Verdict
22.1	Appliance marked with the first numeral of the IP system, relevant requirements of IEC 60529 are fulfilled		N/A
22.2	Stationary appliance: means to ensure all-pole disconnection from the supply being provided:		--
	- a supply cord fitted with a plug, or		N/A
	- a switch complying with 24.3, or		N/A
	- a statement in the instruction sheet that a disconnection incorporated in the fixed wiring is to be provided, or		N/A
	- an appliance inlet		N/A
	Single-pole switches and single-pole protective devices for the disconnection of heating elements in single-phase, permanently connected class 01 and class I appliances, connected to the phase conductor		N/A
22.3	Appliance provided with pins: no undue strain on socket-outlets		N/A
	Applied torque not exceeding 0.25 Nm		N/A
	Pull force of 50N to each pin after the appliance has being placed in the heating cabinet; when cooled to room temperature the pins are not displaced by more than 1mm		N/A
	Each pin subjected to a torque of 0.4Nm; the pins are not rotating, unless		N/A
	rotating does not impair compliance with this standard		N/A
22.4	Appliance for heating liquids and appliance causing undue vibration not provided with pins for insertion into socket-outlets		P
22.5	No risk of electric shock when touching the pins of the plug, for appliances having a capacitor with rated capacitance equal to or greater than 0,1µF, the appliance being disconnected from the supply at the instant of voltage peak		P
	Voltage not exceeding 34 V (V)	1 V	P
	If compliance relies on the operation of an electronic circuit, the electromagnetic phenomena tests of 19.11.4.3 and 19.11.4.4 are applied		N/A
	The discharge test is then repeated three times, voltage not exceeding 34 V (V).....		N/A
22.6	Electrical insulation not affected by condensing water or leaking liquid		P

IEC 60335-2-25			
Clause	Requirement - Test	Result - Remark	Verdict
	Electrical insulation of Class II appliances not affected if a hose ruptures or seal leaks		N/A
	In case of doubt, test as described		N/A
22.7	Adequate safeguards against the risk of excessive pressure in appliances containing liquid or gases or having steam-producing devices		P
22.8	Electrical connections not subject to pulling during cleaning of compartments to which access can be gained without the aid of a tool, and that are likely to be cleaned in normal use		P
22.9	Insulation, internal wiring, windings, commutators and slip rings not exposed to oil, grease or similar substances, unless		N/A
	the substance has adequate insulating properties		N/A
22.10	Not possible to reset voltage-maintained non-self-resetting thermal cut-outs by the operation of an automatic switching device incorporated within the appliance, if:		N/A
	- a non-self-resetting thermal cut-out is required by the standard, and		N/A
	- a voltage maintained non-self-resetting thermal cut-out is used to meet it		N/A
	Non-self-resetting thermal motor protectors have a trip-free action, unless		N/A
	they are voltage maintained		N/A
	Reset buttons of non-self-resetting controls so located or protected that accidental resetting is unlikely		N/A
22.11	Reliable fixing of non-detachable parts that provide the necessary degree of protection against electric shock, moisture or contact with moving parts		P
	Obvious locked position of snap-in devices used for fixing such parts		N/A
	No deterioration of the fixing properties of snap-in devices used in parts that are likely to be removed during installation or servicing		N/A
	Tests as described	Control panel, enclosure, knob	P
22.12	Handles, knobs etc. fixed in a reliable manner		P
	Fixing in wrong position of handles, knobs etc. indicating position of switches or similar components not possible		P

IEC 60335-2-25			
Clause	Requirement - Test	Result - Remark	Verdict
	Axial force 15 N applied to parts, the shape being so that an axial pull is unlikely to be applied		P
	Axial force 30 N applied to parts, the shape being so that an axial pull is likely to be applied		P
22.13	Unlikely that handles, when gripped as in normal use, make the operator's hand touch parts having a temperature rise exceeding the value specified for handles which are held for short periods only		P
22.14	No ragged or sharp edges creating a hazard for the user in normal use, or during user maintenance		P
	No exposed pointed ends of self-tapping screws or other fasteners, likely to be touched by the user in normal use or during user maintenance		N/A
22.15	Storage hooks and the like for flexible cords smooth and well rounded		N/A
22.16	Automatic cord reels cause no undue abrasion or damage to the sheath of the flexible cord, no breakage of conductors strands and no undue wear of contacts		N/A
	Cord reel tested with 6000 operations, as specified		N/A
	Electric strength test of 16.3, voltage of 1000 V applied		N/A
22.17	Spacers not removable from the outside by hand or by means of a screwdriver or a spanner		N/A
22.18	Current-carrying parts and other metal parts resistant to corrosion		P
22.19	Driving belts not relied upon to provide the required level of insulation, unless		N/A
	constructed to prevent inappropriate replacement		N/A
22.20	Direct contact between live parts and thermal insulation effectively prevented, unless		N/A
	material used is non-corrosive, non-hygroscopic and non-combustible		N/A
22.21	Wood, cotton, silk, ordinary paper and fibrous or hygroscopic material not used as insulation, unless		P
	impregnated		N/A
	This requirement does not apply to magnesium oxide and mineral ceramic fibres used for the electrical insulation of heating elements		N/A
22.22	Appliances not containing asbestos		P
22.23	Oils containing polychlorinated biphenyl (PCB) not used		P

IEC 60335-2-25			
Clause	Requirement - Test	Result - Remark	Verdict
22.24	Bare heating elements, except in class III appliances or class III constructions that do not contain live parts, adequately supported		N/A
	In case of rupture, the heating conductor is unlikely to come in contact with accessible metal parts		N/A
22.25	Sagging heating conductors, except in class III appliances or class III constructions that do not contain live parts, cannot come into contact with accessible metal parts		N/A
22.26	For class III constructions the insulation between parts operating at safety extra-low voltage and other live parts complies with the requirements for double or reinforced insulation		N/A
22.27	Parts connected by protective impedance separated by double or reinforced insulation		P
22.28	Metal parts of Class II appliances conductively connected to gas pipes or in contact with water, separated from live parts by double or reinforced insulation		N/A
22.29	Class II appliances permanently connected to fixed wiring so constructed that the required degree of access to live parts is maintained after installation		N/A
22.30	Parts serving as supplementary or reinforced insulation fixed so that they cannot be removed without being seriously damaged, or		N/A
	so constructed that they cannot be replaced in an incorrect position, and so that if they are omitted, the appliance is rendered inoperable or manifestly incomplete		P
22.31	Neither clearances nor creepage distances over supplementary and reinforced insulation reduced below values specified in clause 29 as a result of wear		P
	Neither clearances nor creepage distances between live parts and accessible parts reduced below values for supplementary insulation if wires, screws etc. become loose		P
22.32	Supplementary and reinforced insulation constructed or protected against pollution so that clearances or creepage distances are not reduced below the values in clause 29		P
	Supplementary insulation of natural or synthetic rubber resistant to ageing, or arranged and dimensioned so that creepage distances are not reduced below values specified in 29.2		N/A

IEC 60335-2-25			
Clause	Requirement - Test	Result - Remark	Verdict
	Ceramic material not tightly sintered, similar materials or beads alone not used as supplementary or reinforced insulation		N/A
	Ceramic and similar porous material in which heating conductors are embedded is considered to be basic insulation, not reinforced insulation		N/A
	Oxygen bomb test at 70 °C for 96 h and 16 h at room temperature		N/A
22.33	Conductive liquids that are or may become accessible in normal use and conductive liquids that are in contact with unearthed accessible metal parts are not in direct contact with live parts, or		P
	unearthed metal parts separated from live parts by basic insulation only		N/A
	Electrodes not used for heating liquids		N/A
	For class II constructions, conductive liquids that are or may become accessible in normal use and conductive liquids that are in contact with unearthed accessible metal parts, not in direct contact with basic or reinforced insulation, unless		N/A
	the reinforced insulation consists of at least 3 layers		N/A
	For class II constructions, conductive liquids which are in contact with live parts, not in direct contact with reinforced insulation, unless		N/A
	the reinforced insulation consists of at least 3 layers		N/A
	An air layer not used as basic or supplementary insulation in a double insulation system if likely to be bridged by leaking liquid		N/A
22.34	Shafts of operating knobs, handles, levers etc. not live, unless		P
	the shaft is not accessible when the part is removed		P
22.35	For other than class III constructions, handles, levers and knobs, held or actuated in normal use, not becoming live in the event of a failure of basic insulation		P
	Such parts being of metal, and their shafts or fixings are likely to become live in the event of a failure of basic insulation, are either adequately covered by insulation material or their accessible parts are separated from their shafts or fixings by supplementary insulation		N/A

IEC 60335-2-25			
Clause	Requirement - Test	Result - Remark	Verdict
	This requirement does not apply to handles, levers and knobs on stationary appliances and cordless appliances, other than those of electrical components, provided they are reliably connected to an earthing terminal or earthing contact, or separated from live parts by earthed metal		N/A
	Insulating material covering metal handles, levers and knobs withstand the electric strength test of 16.3 for supplementary insulation		N/A
22.36	For appliances other than class III, handles continuously held in the hand in normal use so constructed that when gripped as in normal use, the operators hand is not likely to touch metal parts, unless		N/A
	they are separated from live parts by double or reinforced insulation		N/A
22.37	Capacitors in Class II appliances not connected to accessible metal parts and their casings, if of metal, separated from accessible metal parts by supplementary insulation, unless		N/A
	the capacitors comply with 22.42		N/A
22.38	Capacitors not connected between the contacts of a thermal cut-out		P
22.39	Lamp holders used only for the connection of lamps		P
22.40	Motor-operated appliances and combined appliances intended to be moved while in operation, or having accessible moving parts, fitted with a switch to control the motor. The actuating member of the switch being easily visible and accessible		N/A
	If the appliance cannot operate continuously, automatically or remotely without giving rise to a hazard, appliances for remote operation being fitted with a switch for stopping the operation. The actuating member of the switch being easily visible and accessible		N/A
22.41	No components, other than lamps, containing mercury		P
22.42	Protective impedance consisting of at least two separate components		N/A
	Values specified in 8.1.4 not exceeded if any one of the components are short-circuited or open-circuited		N/A
	Resistors checked by the test of 14.1 a) in IEC 60065		N/A

IEC 60335-2-25			
Clause	Requirement - Test	Result - Remark	Verdict
	Capacitors checked by the tests for class Y capacitors in IEC 60384-14		N/A
22.43	Appliances adjustable for different voltages, accidental changing of the setting of the voltage unlikely to occur		N/A
22.44	Appliances not having an enclosure that is shaped or decorated like a toy		P
22.45	When air is used as reinforced insulation, clearances not reduced below the values specified in 29.1.3 due to deformation as a result of an external force applied to the enclosure		P
22.46	For programmable protective electronic circuits used to ensure compliance with the standard, the software contains measures to control the fault/error conditions in table R.1		N/A
	Software that contains measures to control the fault/error conditions specified in table R.2 is to be specified in parts 2 for particular constructions or to address specific hazards		N/A
	These requirements are not applicable to software used for functional purpose or compliance with clause 11		N/A
22.47	Appliances connected to the water mains withstand the water pressure expected in normal use		N/A
	No leakage from any part, including any inlet water hose		N/A
22.48	Appliances connected to the water mains constructed to prevent backsiphonage of non-potable water		N/A
22.49	For remote operation, the duration of operation is to be set before the appliance can be started, unless		N/A
	the appliance switches off automatically or can operate continuously without hazard		N/A
22.50	Controls incorporated in the appliance take priority over controls actuated by remote operation		N/A
22.51	There is a control on the appliance manually adjusted to the setting for remote operation before the appliance can be operated in this mode		N/A
	There is a visual indication showing that the appliance is adjusted for remote operation		N/A
	These requirements not necessary on appliances that can operate as follows, without giving rise to a hazard:		--
	- continuously, or		N/A
	- automatically, or		N/A

IEC 60335-2-25			
Clause	Requirement - Test	Result - Remark	Verdict
	- remotely		N/A
22.52	Socket-outlets on appliances accessible to the user in accordance with the socket-outlet system used in the country in which the appliance is sold		N/A
22.53	Class II appliances and class III appliances that incorporate functionally earthed parts have at least double insulation or reinforced insulation between live parts and the functionally earthed parts		N/A
22.54	Button cells and batteries designated R1 not accessible without the aid of a tool, unless		N/A
	the cover of their compartment can only be opened after at least two independent movements have been applied simultaneously		N/A
22.101	Built-in appliances shall only be vented through the front, unless provisions are made for venting through a duct (IEC 60335-2-25)		N/A
22.102	Creepage distances and clearances between bare live parts and other parts not affected by grease or moisture discharged through vents (IEC 60335-2-25)		P
22.103	The appliances shall be constructed in compliance with either 22.103.1 or 22.103.2 (IEC 60335-2-25)		--
22.103.1	Appliances shall incorporate at least two door interlocks that are operated by opening the door, one being a monitored door interlock. At least one of the door interlocks shall be concealed and not operable by manipulation. Compliance is checked by inspection and concealment is checked by 22.105.		P
22.103.2	Appliances shall incorporate two independent monitored door interlocks that are operated by opening the door. In this case, 22.105 are not applicable.		N/A
22.104	Switch contact of at least one door interlock disconnects microwave generator from its supply main circuit (IEC 60335-2-25)		P
22.105	At least one door interlock concealed and not operable by manipulation: use of test probe B of IEC61032 and straight rod (IEC 60335-2-25)		P
	The door interlock operates before any accessible door interlock can be defeated		P
22.106	Failure of monitored door safety interlock causes the appliance to become inoperable (IEC 60335-2-25)		P
	Door cannot be opened,		N/A
	or microwave generator shuts down		P

IEC 60335-2-25			
Clause	Requirement - Test	Result - Remark	Verdict
	Shorting switch does not fail in the open position		P
	Additional test in case of fuse rupture:		P
	- 2 attempts : the fuse ruptures each time		P
	- 3 attempts with impedance of $(0,4+j0,25)\Omega$: the fuse ruptures each time		P
22.107	Failure of any single component affecting the operation of a door interlock does not cause any other interlock to become inoperative, unless appliance rendered inoperable (IEC 60335-2-25)		P
22.108	The door interlocks incorporated to comply with 22.103 shall operate before undue microwave leakage occurs : (IEC 60335-2-25)	1,8 W/m ² (limit: 50 W/m ²)	P
22.109	No undue microwave leakage by thin material introduced between door and mating surface (IEC 60335-2-25)	2,2 W/m ² (limit: 50 W/m ²)	P
22.110	Door seal contamination by food residues does not cause undue microwave leakage (IEC 60335-2-25)	2,4 W/m ² (limit: 50 W/m ²)	P
22.111	No undue microwave leakage if door corners subjected to mechanical distortion of max. 40N (IEC 60335-2-25)		P
	during the test: energy flux density not exceed 100W/m ²	2,7 W/m ² (limit: 100 W/m ²)	P
	after removing the force: compliance with clause 32	2,7 W/m ² (limit: 50 W/m ²)	P
22.112	No undue microwave leakage if temperature sensing probe or its cord is trapped by the door		N/A
	No damage for the temperature sensing probe		N/A
	during the test: energy flux density not exceed 100W/m ²		N/A
	after the test: compliance with clause 32		N/A
	after the test: temperature sensing probe complies with 8.1, 15.101 and 29		N/A
22.113	No undue microwave leakage if detachable parts are removed (IEC 60335-2-25)	2,2 W/m ² (limit: 50 W/m ²)	P
22.114	single fault (for example failure of basic insulation or a loose wire bridging the insulation system) not allow operation of the microwave generator with the door open. (IEC 60335-2-25)		P
22.115	No access to the cavity through the viewing screen by use of 1 mm straight steel rod (IEC 60335-2-25)		P

IEC 60335-2-25			
Clause	Requirement - Test	Result - Remark	Verdict
22.116	Appliances for installing in road vehicles, caravans and similar vehicles etc, shall withstand the vibrations to which they may be subjected (IEC 60335-2-25)		N/A
	Vibration tests specified in IEC 60068-2-6 under conditions specified in IEC 60335-2-25		N/A
	Compliance with 8.1, 16.3 and clauses 29 and 32, and connections shall not have worked loose		N/A
22.117	If electronic circuits are used to provide protection against microwave leakage they shall be designed so that a fault condition will not affect protection against microwave leakage. (IEC 60335-2-25)		N/A
	Compliance is checked by applying the tests in Clause 19 in conjunction with the requirements and test specifications in 22.105, 22.106, 22.107 and 22.108.		N/A
22.118	Inadvertent operations during handling of the container during normal use of fixed appliances and built-in appliances being used equal or higher than 900 mm above the floor having detachable turntables shall not lead to a hazardous situation due to falling down turntables. This is not applicable for appliances with horizontal bottom hinged door. (IEC 60335-2-25)		N/A
	During the test, the turntable shall not slide out of the cavity and fall down.		N/A
22.119	Outer glass panels of microwave oven doors which break during the test of 21.104 and with an area having any two orthogonal dimensions exceeding 75 mm shall be made from (IEC 60335-2-25)		--
	– glass that breaks into small pieces when it fractures; or	Outer glass panels was not break during the test of 21.104	N/A
	– glass that is not released or dropped from its normal position when broken; or		N/A
	glass with enhanced mechanical strength		N/A
	the tests the glass shall not be broken or cracked.		N/A
23	INTERNAL WIRING		--
23.1	Wireways smooth and free from sharp edges		P
	Wires protected against contact with burrs, cooling fins etc.		P
	Wire holes in metal well-rounded or provided with bushings		N/A
	Wiring effectively prevented from coming into contact with moving parts		P
23.2	Beads etc. on live wires cannot change their position, and are not resting on sharp edges		N/A
	Beads inside flexible metal conduits contained within an insulating sleeve		N/A

IEC 60335-2-25			
Clause	Requirement - Test	Result - Remark	Verdict
23.3	Electrical connections and internal conductors movable relatively to each other not exposed to undue stress		N/A
	Flexible metallic tubes not causing damage to insulation of conductors		N/A
	Open-coil springs not used		N/A
	Adequate insulating lining provided inside a coiled spring, the turns of which touch one another		N/A
	No damage after 10 000 flexings for conductors flexed during normal use, or		N/A
	100 flexings for conductors flexed during user maintenance		N/A
	Electric strength test of 16.3, 1000 V between live parts and accessible metal parts		N/A
	Not more than 10% of the strands of any conductor broken, and		N/A
	not more than 30% for wiring supplying circuits that consume no more than 15W		N/A
23.4	Bare internal wiring sufficiently rigid and fixed		N/A
23.5	The insulation of internal wiring subjected to the supply mains voltage withstanding the electrical stress likely to occur in normal use		P
	Basic insulation electrically equivalent to the basic insulation of cords complying with IEC 60227 or IEC 60245, or		N/A
	no breakdown when a voltage of 2000 V is applied for 15 min between the conductor and metal foil wrapped around the insulation		P
	For class II construction, the requirements for supplementary insulation and reinforced insulation apply,		N/A
	except that the sheath of a cord complying with IEC 60227 or IEC 60245 may provide supplementary insulation.		N/A
	A single layer of internal wiring insulation does not provide reinforced insulation		P
23.6	Sleeving used as supplementary insulation on internal wiring retained in position by clamping at both ends, or		N/A
	be such that it can only be removed by breaking or cutting		N/A
23.7	The colour combination green/yellow only used for earthing conductors		P

IEC 60335-2-25			
Clause	Requirement - Test	Result - Remark	Verdict
23.8	Aluminium wires not used for internal wiring	No aluminium wires used	N/A
23.9	Stranded conductors not consolidated by soldering where they are subjected to contact pressure, unless		P
	the contact pressure is provided by spring terminals		N/A
23.10	The insulation and sheath of internal wiring, incorporated in external hoses for the connection of an appliance to the water mains, at least equivalent to that of light polyvinyl chloride sheathed flexible cord (60227 IEC 52)		N/A
24	COMPONENTS		--
24.1	Components comply with safety requirements in relevant IEC standards		P
	List of components	(see appended table)	P
	Motors not required to comply with IEC 60034-1, they are tested as part of the appliance		P
	Relays tested as part of the appliance, or		N/A
	alternatively acc. to IEC 60730-1, and meeting the additional requirements in IEC 60335-1		P
	The requirements of Clause 29 apply between live parts of components and accessible parts of the appliance		P
	Components can comply with the requirements for clearances and creepage distances for functional insulation in the relevant component standard		P
	30.2 of this standard apply to parts of non-metallic material in components including parts of non-metallic material supporting current-carrying connections		P
	Components that have not been previously tested to comply with the IEC standard for the relevant component are tested according to the requirements of 30.2		P
	Components that have been previously tested to comply with the resistance to fire requirements in the IEC standard for the relevant component need not be retested provided the specified conditions are met		P
	If these conditions are not satisfied, the component is tested as part of the appliance.		P
	Power electronic converter circuits not required to comply with IEC 62477-1, they are tested as part of the appliance		P

IEC 60335-2-25			
Clause	Requirement - Test	Result - Remark	Verdict
	If components have not been tested and found to comply with relevant IEC standard for the number of cycles specified, they are tested in accordance with 24.1.1 to 24.1.9		P
	For components mentioned in 24.1.1 to 24.1.9 no additional tests specified in the relevant component standard are necessary other than those specified in 24.1.1 to 24.1.9		P
	Components not tested and found to comply with relevant IEC standard and components not marked or not used in accordance with its marking, tested under the conditions occurring in the appliance		P
	Lampholders and starterholders that have not being tested and found to comply with the relevant IEC standard, tested as a part of the appliance and additionally according to the gauging and interchangeability requirements of the relevant IEC standard		N/A
	No additional tests specified for nationally standardized plugs such as those detailed in IEC/TR 60083 or connectors complying with the standard sheets of IEC 60320-1 and IEC 60309		P
24.1.1	Capacitors likely to be permanently subjected to the supply voltage and used for radio interference suppression or for voltage dividing, complying with IEC 60384-14		P
	If the capacitors have to be tested, they are tested according to Annex F		N/A
24.1.2	Transformers in associated switch mode power supplies comply with Annex BB of IEC 61558-2-16		P
	Safety isolating transformers complying with IEC 61558-2-6		N/A
	If they have to be tested, they are tested according to Annex G		N/A
24.1.3	Switches complying with IEC 61058-1, the number of cycles of operation being at least 10 000		P
	If they have to be tested, they are tested according to Annex H		N/A
	If the switch operates a relay or contactor, the complete switching system is subjected to the test		N/A
	If the switch only operates a motor starting relay complying with IEC 60730-2-10 with the number of cycles of a least 10 000 as specified, the complete switching system need not be tested		N/A
24.1.4	Automatic controls complying with IEC 60730-1 with the relevant part 2. The number of cycles of operation being at least:		--

IEC 60335-2-25			
Clause	Requirement - Test	Result - Remark	Verdict
	- thermostats: 10 000		N/A
	- temperature limiters: 1 000		N/A
	- self-resetting thermal cut-outs: 300		P
	- voltage maintained non-self-resetting thermal cut-outs: 1 000		N/A
	- other non-self-resetting thermal cut-outs: 30		N/A
	- timers: 3 000		P
	- energy regulators: 10 000		N/A
	Tests on interlocks: 6 samples, rated voltage, load of appliance, 6 cycles per minutes. The number of cycles of operation being: (IEC 60335-2-25)		--
	-Door interlocks, no damages after 50 000		P
	-Interlock only operated during user maintenance, no damages after 5 000		N/A
	The number of cycles for controls operating during clause 11 need not be declared, if the appliance meets the requirements of this standard when they are short-circuited		N/A
	Thermal motor protectors are tested in combination with their motor under the conditions specified in Annex D		N/A
	For water valves containing live parts and that are incorporated in external hoses for connection of an appliance to the water mains, the degree of protection declared for subclause 6.5.2 of IEC 60730-2-8 is IPX7		N/A
	Thermal cut-outs of the capillary type comply with the requirements for type 2.K controls in IEC 60730-2-9		N/A
24.1.5	Appliance couplers complying with IEC 60320-1		N/A
	However, for appliances classified higher than IPX0, the appliance couplers complying with IEC 60320-2-3		N/A
	Interconnection couplers complying with IEC 60320-2-2		N/A
24.1.6	Small lamp holders similar to E10 lampholders complying with IEC 60238, the requirements for E10 lampholders being applicable		P
24.1.7	For remote operation of the appliance via a telecommunication network, the relevant standard for the telecommunication interface circuitry in the appliance is IEC 62151		N/A

IEC 60335-2-25			
Clause	Requirement - Test	Result - Remark	Verdict
24.1.8	The relevant standard for thermal links is IEC 60691		N/A
	Thermal links not complying with IEC 60691 are considered to be an intentionally weak part for the purposes of Clause 19		N/A
24.1.9	Contactors and relays, other than motor starting relays, tested as part of the appliance		P
	They are also tested in accordance with Clause 17 of IEC 60730-1, the number of cycles of operations in 24.1.4 selected according to the contactor or relay function in the appliance.....:		P
24.2	Appliances not fitted with:		--
	- switches or automatic controls in flexible cords		P
	- devices causing the protective device in the fixed wiring to operate in the event of a fault in the appliance		P
	- thermal cut-outs that can be reset by soldering, unless		P
	the solder has a melting point of at least 230 °C		N/A
24.3	Switches intended for all-pole disconnection of stationary appliances are directly connected to the supply terminals and have a contact separation in all poles, providing full disconnection under overvoltage category III conditions		N/A
24.4	Plugs and socket-outlets for extra-low voltage circuits and heating elements, not interchangeable with plugs and socket-outlets listed in IEC/TR 60083 or IEC 60906-1 or with connectors and appliance inlets complying with the standard sheets of IEC 60320-1		N/A
24.5	Capacitors in auxiliary windings of motors marked with their rated voltage and capacitance, and used accordingly		N/A
	Voltage across capacitors in series with a motor winding does not exceed 1,1 times rated voltage, when the appliance is supplied at 1,1 times rated voltage under minimum load		N/A
24.6	Working voltage of motors connected to the supply mains and having basic insulation that is inadequate for the rated voltage of the appliance, not exceeding 42 V		N/A
	In addition, the motors comply with the requirements of Annex I		N/A
24.7	Detachable hose-sets for connection of appliances to the water mains comply with IEC 61770		N/A

IEC 60335-2-25			
Clause	Requirement - Test	Result - Remark	Verdict
	They are supplied with the appliance		N/A
	Appliances intended to be permanently connected to the water mains not connected by a detachable hose-set		N/A
24.8	Motor running capacitors in appliances for which 30.2.3 is applicable and that are permanently connected in series with a motor winding, not causing a hazard in event of a failure		N/A
	One or more of the following conditions are to be met:		--
	- the capacitors are of class P2 according to IEC 60252-1		N/A
	- the capacitors are housed within a metallic or ceramic enclosure		N/A
	- the distance of separation of the outer surface to adjacent non-metallic parts exceeds 50 mm		N/A
	- adjacent non-metallic parts within 50 mm withstand the needle-flame test of Annex E		N/A
	- adjacent non-metallic parts within 50 mm classified as at least V-1 according to IEC 60695-11-10		N/A
24.101	Incorporated socket-outlets: single-phase type, earthing contact, rated current not exceeding 16A (IEC 60335-2-25)		N/A
	Protection of poles: incorporated fuse or circuit-breaker, adequately located, as specified		N/A
	Appliance for fixed wiring: neutral not protected		N/A
25	SUPPLY CONNECTION AND EXTERNAL FLEXIBLE CORDS		--
25.1	Appliance not intended for permanent connection to fixed wiring, means for connection to the supply:		--
	- supply cord fitted with a plug, the current rating and voltage rating of the plug being not less than the corresponding ratings of its associated appliance		P
	- an appliance inlet having at least the same degree of protection against moisture as required for the appliance, or		N/A
	- pins for insertion into socket-outlets		N/A
25.2	Appliance not provided with more than one means of connection to the supply mains		N/A

IEC 60335-2-25			
Clause	Requirement - Test	Result - Remark	Verdict
	Stationary appliance for multiple supply may be provided with more than one means of connection, provided electric strength test of 1250 V for 1 min between each means of connection causes no breakdown		N/A
25.3	Appliance intended to be permanently connected to fixed wiring provided with one of the following means for connection to the supply mains:		--
	- a set of terminals allowing the connection of a flexible cord		N/A
	- a fitted supply cord		N/A
	- a set of supply leads accommodated in a suitable compartment		N/A
	- a set of terminals for the connection of cables of fixed wiring, cross-sectional areas specified in 26.6, and the appliance allows the connection of the supply conductors after the appliance has been fixed to its support		N/A
	- a set of terminals and cable entries, conduit entries, knock-outs or glands, allowing connection of appropriate types of cable or conduit, and the appliance allows the connection of the supply conductors after the appliance has been fixed to its support		N/A
	For a fixed appliance constructed so that parts can be removed to facilitate easy installation, this requirement is met if it is possible to connect the fixed wiring without difficulty after a part of the appliance has been fixed to its support		N/A
25.4	Cable and conduit entries, rated current of appliance not exceeding 16 A, dimension according to table 10 (mm)		N/A
	Introduction of conduit or cable does not reduce clearances or creepage distances below values specified in clause 29		N/A
25.5	Method for assembling the supply cord to the appliance:		--
	- type X attachment		N/A
	- type Y attachment		P
	- type Z attachment, if allowed in relevant part 2		N/A
	Type X attachment, other than those with a specially prepared cord, not used for flat twin tinsel cords		N/A
	For multi-phase appliances supplied with a supply cord and that are intended to be permanently connected to fixed wiring, the supply cord is assembled to the appliance by type Y attachment		N/A

IEC 60335-2-25			
Clause	Requirement - Test	Result - Remark	Verdict
25.6	Plugs fitted with only one flexible cord		P
25.7	Supply cords, other than for class III appliances, being one of the following types:		--
	- rubber sheathed (at least 60245 IEC 53)		N/A
	- polychloroprene sheathed (at least 60245 IEC 57)		N/A
	- polyvinyl chloride sheathed. Not used if they are likely to touch metal parts having a temperature rise exceeding 75 K during the test of clause 11		--
	<ul style="list-style-type: none"> light polyvinyl chloride sheathed cord (60227 IEC 52), for appliances not exceeding 3 kg 		N/A
	<ul style="list-style-type: none"> ordinary polyvinyl chloride sheathed cord (60227 IEC 53), for other appliances 	H05VV-F	P
	- heat resistant polyvinyl chloride sheathed. Not used for type X attachment other than specially prepared cords		--
	<ul style="list-style-type: none"> heat-resistant light polyvinyl chloride sheathed cord (60227 IEC 56), for appliances not exceeding 3 kg 		N/A
	<ul style="list-style-type: none"> heat-resistant polyvinyl chloride sheathed cord (60227 IEC 57), for other appliances 		N/A
	Supply cords for class III appliances adequately insulated		N/A
	Test with 500 V for 2 min for supply cords of class III appliances that contain live parts		N/A
25.8	Nominal cross-sectional area of supply cords not less than table 11; rated current (A); cross-sectional area (mm ²)	Rated current: 5,96 A; cross-sectional area: 3G 1,0 mm ² or 3G 0,75 mm ²	P
25.9	Supply cords not in contact with sharp points or edges		P
25.10	Supply cord of class I appliances have a green/yellow core for earthing		P
	In multi-phase appliances, the colour of the neutral conductor of the supply cord is blue.		N/A
25.11	Conductors of supply cords not consolidated by soldering where they are subject to contact pressure, unless		P
	the contact pressure is provided by spring terminals		N/A
25.12	Insulation of the supply cord not damaged when moulding the cord to part of the enclosure		N/A
25.13	Inlet openings so constructed as to prevent damage to the supply cord		P

IEC 60335-2-25			
Clause	Requirement - Test	Result - Remark	Verdict
	If it is not evident that the supply cord can be introduced without risk of damage,, a non-detachable lining or bushing complying with 29.3 for supplementary insulation provided		P
	If unsheathed supply cord, a similar additional bushing or lining is required, unless the appliance is		N/A
	class 0, or		N/A
	a class III appliance not containing live parts		N/A
25.14	Supply cords moved while in operation adequately protected against excessive flexing		N/A
	Flexing test, as described:		--
	- applied force (N).....:		N/A
	- number of flexings:		N/A
	The test does not result in:		--
	- short-circuit between the conductors, such that the current exceeds a value of twice the rated current		N/A
	- breakage of more than 10% of the strands of any conductor		N/A
	- separation of the conductor from its terminal		N/A
	- loosening of any cord guard		N/A
	- damage to the cord or the cord guard		N/A
	- broken strands piercing the insulation and becoming accessible		N/A
	For temperature sensing probes total number of flexings is 5000; probes with circular section cords are turned through 90° after 2500 flexings (IEC 60335-2-25)		N/A
25.15	For appliances with supply cord and appliances to be permanently connected to fixed wiring by a flexible cord, conductors of the supply cord relieved from strain, twisting and abrasion by use of cord anchorage		P
	The cord cannot be pushed into the appliance to such an extent that the cord or internal parts of the appliance can be damaged		P
	Pull and torque test of supply cord:		--
	- fixed appliances: pull 100 N; torque (not on automatic cord reel) (Nm) :		P

IEC 60335-2-25			
Clause	Requirement - Test	Result - Remark	Verdict
	- other appliances: values shown in table 12: mass (kg); pull (N); torque (not on automatic cord reel) (Nm) :		N/A
	Pull and torque test of supply cord, values shown in table 12: mass (kg); pull (N); torque (not on automatic cord reel) (Nm).....:	Mass: 9,3 kg; Pull: 100 N; Torque: 0,35 Nm	P
	Cord not damaged and max. 2 mm displacement of the cord	0,4 mm	P
25.16	Cord anchorages for type X attachments constructed and located so that:		--
	- replacement of the cord is easily possible		N/A
	- it is clear how the relief from strain and the prevention of twisting are obtained		N/A
	- they are suitable for different types of supply cord		N/A
	- cord cannot touch the clamping screws of cord anchorage if these screws are accessible, unless		N/A
	they are separated from accessible metal parts by supplementary insulation		N/A
	- the cord is not clamped by a metal screw which bears directly on the cord		N/A
	- at least one part of the cord anchorage securely fixed to the appliance, unless		N/A
	it is part of a specially prepared cord		N/A
	- screws which have to be operated when replacing the cord do not fix any other component, unless		N/A
	the appliance becomes inoperative or incomplete or the parts cannot be removed without a tool		N/A
	- if labyrinths can be bypassed the test of 25.15 is nevertheless withstood		N/A
	- for class 0, 0I and I appliances they are of insulating material or are provided with an insulating lining, unless		N/A
	failure of the insulation of the cord does not make accessible metal parts live		N/A
	- for class II appliances they are of insulating material, or		N/A
	if of metal, they are insulated from accessible metal parts by supplementary insulation		N/A
	After the test of 25.15, under the conditions specified, the conductors have not moved by more than 1 mm in the terminals		N/A

IEC 60335-2-25			
Clause	Requirement - Test	Result - Remark	Verdict
25.17	Adequate cord anchorages for type Y and Z attachment, test with the cord supplied with the appliance	Type Y	P
25.18	Cord anchorages only accessible with the aid of a tool, or		P
	Constructed so that the cord can only be fitted with the aid of a tool		N/A
25.19	Type X attachment, glands not used as cord anchorage in portable appliances		N/A
	Tying the cord into a knot or tying the cord with string not used		N/A
25.20	The conductors of the supply cord for type Y and Z attachment additionally insulated from accessible metal parts	Type Y	P
25.21	Space for supply cord for type X attachment or for connection of fixed wiring constructed:		--
	- to permit checking of conductors with respect to correct positioning and connection before fitting any cover		N/A
	- so there is no risk of damage to the conductors or their insulation when fitting the cover		N/A
	- for portable appliances, so that the uninsulated end of a conductor, if it becomes free from the terminal, prevented from contact with accessible metal parts		N/A
	2 N test to the conductor for portable appliances; no contact with accessible metal parts		N/A
25.22	Appliance inlets:		--
	- live parts not accessible during insertion or removal		N/A
	Requirement not applicable to appliance inlets complying with IEC 60320-1		N/A
	- connector can be inserted without difficulty		N/A
	- the appliance is not supported by the connector		N/A
	- not for cold conditions if temp. rise of external metal parts exceeds 75 K during clause 11, unless		N/A
	the supply cord is unlikely to touch such metal parts		N/A
25.23	Interconnection cords comply with the requirements for the supply cord, except that:		N/A
	- the cross-sectional area of the conductors is determined on the basis of the maximum current during clause 11		N/A
	- the thickness of the insulation may be reduced		N/A

IEC 60335-2-25			
Clause	Requirement - Test	Result - Remark	Verdict
	If necessary, electric strength test of 16.3		N/A
25.24	Interconnection cords not detachable without the aid of a tool if compliance with this standard is impaired when they are disconnected		N/A
25.25	Dimensions of pins that are inserted into socket-outlets compatible with the dimensions of the relevant socket-outlet.		N/A
	Dimensions of pins and engagement face in accordance with the dimensions of the relevant plug in IEC/TR 60083		N/A
26	TERMINALS FOR EXTERNAL CONDUCTORS		--
26.1	Appliances provided with terminals or equally effective devices for connection of external conductors		P
	Terminals only accessible after removal of a non-detachable cover, except		P
	for class III appliances that do not contain live parts		N/A
	Earthing terminals may be accessible if a tool is required to make the connections and means are provided to clamp the wire independently from its connection		N/A
26.2	Appliances with type X attachment and appliances for the connection of cables to fixed wiring provided with terminals in which connections are made by means of screws, nuts or similar devices, unless		N/A
	the connections are soldered		N/A
	Screws and nuts not used to fix any other component, except		N/A
	internal conductors, if so arranged that they are unlikely to be displaced when fitting the supply conductors		N/A
	If soldered connections used, the conductor so positioned or fixed that reliance is not placed on soldering alone, unless		N/A
	barriers provided so that neither clearances nor creepage distances between live parts and other metal parts reduced below the values for supplementary insulation if the conductor becomes free at the soldered joint		N/A
26.3	Terminals for type X attachment and for connection of cables of fixed wiring so constructed that the conductor is clamped between metal surfaces with sufficient contact pressure but without damaging the conductor		N/A
	Terminals fixed so that when the clamping means is tightened or loosened:		--

IEC 60335-2-25			
Clause	Requirement - Test	Result - Remark	Verdict
	- the terminal does not become loose		N/A
	- internal wiring is not subjected to stress		N/A
	- neither clearances nor creepage distances are reduced below the values in clause 29		N/A
	Compliance checked by inspection and by the test of subclause 9.6 of IEC 60999-1, the torque applied being equal to two-thirds of the torque specified (Nm)		N/A
	No deep or sharp indentations of the conductors		N/A
26.4	Terminals for type X attachment, except those having a specially prepared cord and those for the connection of cables of fixed wiring, no special preparation of conductors such as by soldering, use of cable lugs, eyelets or similar, and		N/A
	so constructed or placed that conductors prevented from slipping out when clamping screws or nuts are tightened		N/A
26.5	Terminals for type X attachment so located or shielded that if a wire of a stranded conductor escapes, no risk of accidental connection to other parts that result in a hazard		N/A
	Stranded conductor test, 8 mm insulation removed		N/A
	No contact between live parts and accessible metal parts and,		N/A
	for class II constructions, between live parts and metal parts separated from accessible metal parts by supplementary insulation only		N/A
26.6	Terminals for type X attachment and for connection of cables of fixed wiring suitable for connection of conductors with cross-sectional area according to table 13; rated current (A); nominal cross-sectional area (mm ²)		N/A
	If a specially prepared cord is used, terminals need only be suitable for that cord		N/A
26.7	Terminals for type X attachment, except in class III appliances not containing live parts, accessible after removal of a cover or part of the enclosure		N/A
26.8	Terminals for the connection of fixed wiring, including the earthing terminal, located close to each other		N/A
26.9	Terminals of the pillar type constructed and located as specified		N/A
26.10	Terminals with screw clamping and screwless terminals not used for flat twin tinsel cords, unless		N/A

IEC 60335-2-25			
Clause	Requirement - Test	Result - Remark	Verdict
	conductors ends fitted with means suitable for screw terminals		N/A
	Pull test of 5 N to the connection		N/A
26.11	For type Y and Z attachment, soldered, welded, crimped or similar connections may be used	Type Y	P
	For Class II appliances, the conductor so positioned or fixed that reliance is not placed on soldering, welding or crimping alone		N/A
	If soldering, welding or crimping alone used, barriers provided so that clearances and creepage distances between live parts and other metal parts are not reduced below the values for supplementary insulation if the conductor becomes free		N/A
27	PROVISION FOR EARTHING		--
27.1	Accessible metal parts of Class 0I and I appliances permanently and reliably connected to an earthing terminal or earthing contact of the appliance inlet	Class I appliance	P
	Earthing terminals and earthing contacts not connected to the neutral terminal		P
	Class 0, II and III appliances have no provision for earthing		N/A
	Class II appliances and class III appliances can incorporate an earth for functional purposes		N/A
	Safety extra-low voltage circuits not earthed, unless		P
	protective extra-low voltage circuits		N/A
27.2	Clamping means of earthing terminals adequately secured against accidental loosening		P
	Terminals for the connection of external equipotential bonding conductors allow connection of conductors of 2.5 to 6 mm ² , and		N/A
	do not provide earthing continuity between different parts of the appliance, and		N/A
	conductors cannot be loosened without the aid of a tool		N/A
	Requirements not applicable to class II appliances and class III appliances that incorporate an earth for functional purposes		N/A
27.3	For a detachable part having an earth connection and being plugged into another part of the appliance, the earth connection is made before and separated after current-carrying connections when removing the part		N/A

IEC 60335-2-25			
Clause	Requirement - Test	Result - Remark	Verdict
	For appliances with supply cords, current-carrying conductors become taut before earthing conductor, if the cord slips out of the cord anchorage		P
	Requirements not applicable to class II appliances and class III appliances that incorporate an earth for functional purposes		N/A
27.4	No risk of corrosion resulting from contact between parts of the earthing terminal and the copper of the earthing conductor or other metal		P
	Parts providing earthing continuity, other than parts of a metal frame or enclosure, have adequate resistance to corrosion		P
	If of steel, these parts provided with an electroplated coating with a thickness at least 5 μm		N/A
	Adequate protection against rusting of parts of coated or uncoated steel, only intended to provide or transmit contact pressure		P
	In the body of the earthing terminal is a part of a frame or enclosure of aluminium or aluminium alloys, precautions taken to avoid risk of corrosion		N/A
	Requirements not applicable to class II appliances and class III appliances that incorporate an earth for functional purposes		N/A
27.5	Low resistance of connection between earthing terminal and earthed metal parts		P
	This requirement does not apply to connections providing earthing continuity in the protective extra-low voltage circuit, provided the clearances of basic insulation are based on the rated voltage of the appliance		N/A
	Requirements not applicable to class II appliances and class III appliances that incorporate an earth for functional purposes		N/A
	Resistance not exceeding 0,1 Ω at the specified low-resistance test (Ω)	0,003 Ω	P
27.6	The printed conductors of printed circuit boards not used to provide earthing continuity in hand-held appliances.		N/A
	They may be used to provide earthing continuity in other appliances if at least two tracks are used with independent soldering points and the appliance complies with 27.5 for each circuit		N/A
	Requirements not applicable to class II appliances and class III appliances that incorporate an earth for functional purposes		N/A

IEC 60335-2-25			
Clause	Requirement - Test	Result - Remark	Verdict
28	SCREWS AND CONNECTIONS		--
28.1	Fixings, electrical connections and connections providing earthing continuity withstand mechanical stresses		P
	Screws not of soft metal liable to creep, such as zinc or aluminium		P
	Diameter of screws of insulating material min. 3 mm		N/A
	Screws of insulating material not used for any electrical connections or connections providing earthing continuity		N/A
	Screws used for electrical connections or connections providing earthing continuity screwed into metal		P
	Screws not of insulating material if their replacement by a metal screw can impair supplementary or reinforced insulation		N/A
	For type X attachment, screws to be removed for replacement of supply cord or for user maintenance, not of insulating material if their replacement by a metal screw impairs basic insulation		N/A
	For screws and nuts; torque-test as specified in table 14.....:	(see appended table)	P
28.2	Electrical connections and connections providing earthing continuity constructed so that contact pressure is not transmitted through non-ceramic insulating material liable to shrink or distort, unless		P
	there is resiliency in the metallic parts to compensate for shrinkage or distortion of the insulating material		N/A
	This requirement does not apply to electrical connections in circuits of appliances for which:		--
	<ul style="list-style-type: none"> 30.2.2 is applicable and that carry a current not exceeding 0,5 A 		N/A
	<ul style="list-style-type: none"> 30.2.3 is applicable and that carry a current not exceeding 0,2 A 		N/A
28.3	Space-threaded (sheet metal) screws only used for electrical connections if they clamp the parts together		N/A
	Thread-cutting (self-tapping) screws and thread rolling screws only used for electrical connections if they generate a full form standard machine screw thread		N/A

IEC 60335-2-25			
Clause	Requirement - Test	Result - Remark	Verdict
	Thread-cutting (self-tapping) screws not used if they are likely to be operated by the user or installer		P
	Thread-cutting, thread rolling and space threaded screws may be used in connections providing earthing continuity provided it is not necessary to disturb the connection:		--
	- in normal use,		P
	- during user maintenance,		P
	- when replacing a supply cord having a type X attachment, or		N/A
	- during installation		P
	At least two screws being used for each connection providing earthing continuity, unless		P
	the screw forms a thread having a length of at least half the diameter of the screw		N/A
28.4	Screws and nuts that make mechanical connection secured against loosening if they also make electrical connections or connections providing earthing continuity		P
	This requirement does not apply to screws in the earthing circuit if at least two screws are used, or		P
	if an alternative earthing circuit is provided		N/A
	Rivets for electrical connections or connections providing earthing continuity secured against loosening if the connections are subjected to torsion		N/A
29	CLEARANCES, CREEPAGE DISTANCES AND SOLID INSULATION		--
	Clearances, creepage distances and solid insulation withstand electrical stress		P
	For coatings used on printed circuits boards to protect the microenvironment (Type 1) or to provide basic insulation (Type 2), Annex J applies		N/A
	The microenvironment is pollution degree 1 under type 1 protection		N/A
	For type 2 protection, the spacing between the conductors before the protection is applied is not less than the values specified in Table 1 of IEC 60664-3		N/A
	These values apply to functional, basic, supplementary and reinforced insulation.....		N/A

IEC 60335-2-25			
Clause	Requirement - Test	Result - Remark	Verdict
29.1	Clearances not less than the values specified in table 16, taking into account the rated impulse voltage for the overvoltage categories of table 15, unless.....:	(see appended table)	P
	for basic insulation and functional insulation they comply with the impulse voltage test of clause 14		N/A
	However, if the distances are affected by wear, distortion, movement of the parts or during assembly, the clearances for rated impulse voltages of 1500V and above are increased by 0,5 mm and the impulse voltage test is not applicable		P
	For appliances intended for use at altitudes exceeding 2 000 m, the clearances in Table 16 is increased according to the relevant multiplier values in Table A.2 of IEC 60664-1		N/A
	Impulse voltage test is not applicable:		--
	- when the microenvironment is pollution degree 3, or		N/A
	- for basic insulation of class 0 and class 01 appliances		N/A
	- to appliances intended for use at altitudes exceeding 2 000 m		N/A
	Appliances are in overvoltage category II		N/A
	A force of 2 N is applied to bare conductors, other than heating elements		P
	A force of 30 N is applied to accessible surfaces		P
29.1.1	Clearances of basic insulation withstand the overvoltages, taking into account the rated impulse voltage		P
	The values of table 16 or the impulse voltage test of clause 14 are applicable.....:	(see appended table)	P
	Clearance at the terminals of tubular sheathed heating elements may be reduced to 1,0 mm if the microenvironment is pollution degree 1		N/A
	Lacquered conductors of windings considered to be bare conductors		P
29.1.2	Clearances of supplementary insulation not less than those specified for basic insulation in table 16	(see appended table)	P
29.1.3	Clearances of reinforced insulation not less than those specified for basic insulation in table 16, using the next higher step for rated impulse voltage	(see appended table)	P

IEC 60335-2-25			
Clause	Requirement - Test	Result - Remark	Verdict
	For double insulation, with no intermediate conductive part between basic and supplementary insulation, clearances are measured between live parts and the accessible surface, and the insulation system is treated as reinforced insulation		P
29.1.4	Clearances for functional insulation are the largest values determined from:		--
	- table 16 based on the rated impulse voltage	(see appended table)	P
	- table F.7a in IEC 60664-1, frequency not exceeding 30 kHz		N/A
	- clause 4 of IEC 60664-4, frequency exceeding 30 kHz		N/A
	If values of table 16 are largest, the impulse voltage test of clause 14 may be applied instead, unless		P
	the microenvironment is pollution degree 3, or		N/A
	the distances can be affected by wear, distortion, movement of the parts or during assembly		P
	However, clearances are not specified if the appliance complies with clause 19 with the functional insulation short-circuited		N/A
	Lacquered conductors of windings considered to be bare conductors		P
	However, clearances at crossover points are not measured		P
	Clearance between surfaces of PTC heating elements may be reduced to 1mm		N/A
29.1.5	Appliances having higher working voltages than rated voltage, clearances for basic insulation are the largest values determined from:		--
	- table 16 based on the rated impulse voltage	H.V. transformer: working voltage: 2300 Vr.m.s. working voltage: 4480 Vp rated voltage: 240 Vr.m.s. required cl 6,0 mm / cr 20,0 mm; Magnetron: working voltage: 2530 Vr.m.s. working voltage: 3900 Vp rated voltage: 240 Vr.m.s. required cl 6,0 mm / cr 25,0	P
	- table F.7a in IEC 60664-1, frequency not exceeding 30 kHz		N/A
	- clause 4 of IEC 60664-4, frequency exceeding 30 kHz		N/A

IEC 60335-2-25			
Clause	Requirement - Test	Result - Remark	Verdict
	If clearances for basic insulation are selected from Table F.7a of IEC 60664-1 or Clause 4 of IEC 60664-4, the clearances of supplementary insulation are not less than those specified for basic insulation		N/A
	If clearances for basic insulation are selected from Table F.7a of IEC 60664-1, the clearances of reinforced insulation dimensioned as specified in Table F.7a are to withstand 160% of the withstand voltage required for basic insulation		N/A
	If clearances for basic insulation are selected from Clause 4 of IEC 60664-4, the clearances of reinforced insulation are twice the value required for basic insulation		N/A
	If the secondary winding of a step-down transformer is earthed, or if there is an earthed screen between the primary and secondary windings, clearances of basic insulation on the secondary side not less than those specified in table 16, but using the next lower step for rated impulse voltage		N/A
	Circuits supplied with a voltage lower than rated voltage, clearances of functional insulation are based on the working voltage used as the rated voltage in table 15		N/A
29.2	Creepage distances not less than those appropriate for the working voltage, taking into account the material group and the pollution degree.....:	(see appended table)	P
	Pollution degree 2 applies, unless		P
	- precautions taken to protect the insulation; pollution degree 1		N/A
	- insulation subjected to conductive pollution; pollution degree 3		N/A
	A force of 2 N is applied to bare conductors, other than heating elements		P
	A force of 30 N is applied to accessible surfaces		P
	In a double insulation system, the working voltage for both the basic and supplementary insulation is taken as the working voltage across the complete double insulation system		P
29.2.1	Creepage distances of basic insulation not less than specified in table 17.....:	(see appended table)	P

IEC 60335-2-25			
Clause	Requirement - Test	Result - Remark	Verdict
	However, if the working voltage is periodic and has a frequency exceeding 30 kHz, the creepage distances are also determined from table 2 of IEC 60664-4, these values being used if exceeding the values in table 17.....:		N/A
	Except for pollution degree 1, corresponding creepage distance not less than the minimum specified for the clearance in table 16, if the clearance has been checked according to the test of clause 14.....:		N/A
29.2.2	Creepage distances of supplementary insulation at least those specified for basic insulation in table 17, or.....:	(see appended table)	P
	Table 2 of IEC 60664-4, as applicable		N/A
29.2.3	Creepage distances of reinforced insulation at least double those specified for basic insulation in table 17, or.....:	(see appended table)	P
	Table 2 of IEC 60664-4, as applicable		N/A
29.2.4	Creepage distances of functional insulation not less than specified in table 18.....:	(see appended table)	P
	However, if the working voltage is periodic and has a frequency exceeding 30 kHz, the creepage distances are also determined from table 2 of IEC 60664-4, these values being used if exceeding the values in table 18.....:		N/A
	Creepage distances may be reduced if the appliance complies with clause 19 with the functional insulation short-circuited		N/A
29.3	Supplementary and reinforced insulation have adequate thickness, or a sufficient number of layers, to withstand the electrical stresses		P
	Compliance checked:		--
	- by measurement, in accordance with 29.3.1, or		P
	- by an electric strength test in accordance with 29.3.2, or		P
	- - for insulation, other than single layer internal wiring insulation, by an assessment of the thermal quality of the material combined with an electric strength test, in accordance with 29.3.3, and	Opto-coupler	P
	for accessible parts of reinforced insulation consisting of a single layer, by measurement in accordance with 29.3.4, or		N/A

IEC 60335-2-25			
Clause	Requirement - Test	Result - Remark	Verdict
	- by an assessment of the thermal quality of the material according to 29.3.3 combined with an electric strength test in accordance with 23.5, for each single layer internal wiring insulation touching each other, or		N/A
	- as specified in subclause 6.3 of IEC 60664-4 for insulation that is subjected to any periodic voltage having a frequency exceeding 30 kHz		N/A
29.3.1	Supplementary insulation have a thickness of at least 1 mm	Thickness of control panel: 2,5 mm	P
	Reinforced insulation have a thickness of at least 2 mm		N/A
29.3.2	Each layer of material withstand the electric strength test of 16.3 for supplementary insulation		P
	Supplementary insulation consist of at least 2 layers		N/A
	Reinforced insulation consist of at least 3 layers		P
29.3.3	The insulation is subjected to the dry heat test Bb of IEC 60068-2-2, followed by		N/A
	the electric strength test of 16.3		P
	If the temperature rise during the tests of clause 19 does not exceed the value specified in table 3, the test of IEC 60068-2-2 is not carried out		P
29.3.4	Thickness of accessible parts of reinforced insulation consisting of a single layer not less than specified in table 19		N/A
30	RESISTANCE TO HEAT AND FIRE		--
30.1	External parts of non-metallic material,		P
	parts supporting live parts, and		P
	parts of thermoplastic material providing supplementary or reinforced insulation		P
	sufficiently resistant to heat		P
	Ball-pressure test according to IEC 60695-10-2		P
	External parts tested at 40 °C plus the maximum temperature rise determined during the test of clause 11, or at 75 °C, whichever is the higher; temperature (°C).....:	(see appended table)	P
	Parts supporting live parts tested at 40°C plus the maximum temperature rise determined during the test of clause 11, or at 125 °C, whichever is the higher; temperature (°C).....:	(see appended table)	P

IEC 60335-2-25			
Clause	Requirement - Test	Result - Remark	Verdict
	Parts of thermoplastic material providing supplementary or reinforced insulation tested at 25 °C plus the maximum temperature rise determined during clause 19, if higher; temperature (°C).....:		N/A
30.2	Parts of non-metallic material resistant to ignition and spread of fire		P
	This requirement does not apply to:		--
	parts having a mass not exceeding 0,5 g, provided the cumulative effect is unlikely to propagate flames that originate inside the appliance by propagating flames from one part to another, or		N/A
	decorative trims, knobs and other parts unlikely to be ignited or to propagate flames that originate inside the appliance		P
	Compliance checked by the test of 30.2.1, and in addition:		P
	- for attended appliances, 30.2.2 applies		N/A
	- for unattended appliances, 30.2.3 applies		P
	For appliances for remote operation, 30.2.3 applies		N/A
	For base material of printed circuit boards, 30.2.4 applies		P
	For appliances with preselected start-time, and those with a keep-warm function, 30.2.3 applies (IEC 60335-2-25)		P
	For other appliances, 30.2.2 applies (IEC 60335-2-25)		N/A
30.2.1	Parts of non-metallic material subjected to the glow-wire test of IEC 60695-2-11 at 550 °C	(See appended table)	P
	However, test not carried out if the material is classified as having a glow-wire flammability index according to IEC 60695-2-12 of at least 550 °C, or		N/A
	the material is classified at least HB40 according to IEC 60695-11-10		N/A
	Parts for which the glow-wire test cannot be carried out need to meet the requirements in ISO 9772 for material classified HBF		N/A
30.2.2	Appliances operated while attended, parts of non-metallic material supporting current-carrying connections, and		N/A
	parts of non-metallic material within a distance of 3mm of such connections,		N/A
	subjected to the glow-wire test of IEC 60695-2-11		N/A
	The test severity is:		--

IEC 60335-2-25			
Clause	Requirement - Test	Result - Remark	Verdict
	- 750 °C, for connections carrying a current exceeding 0,5 A during normal operation		N/A
	- 650 °C, for other connections		N/A
	Glow-wire applied to an interposed shielding material, if relevant		N/A
	The glow-wire test is not carried out on parts of material classified as having a glow-wire flammability index according to IEC 60695-2-12 of at least:		--
	- 750 °C, for connections carrying a current exceeding 0,5 A during normal operation		N/A
	- 650 °C, for other connections		N/A
	The glow-wire test is also not carried out on small parts. These parts are to:		--
	- comprise material having a glow-wire flammability index of at least 750 °C, or 650 °C as appropriate, or		N/A
	- comply with the needle-flame test of Annex E, or		N/A
	- comprise material classified as V-0 or V-1 according to IEC 60695-11-10		N/A
	Glow-wire test not applicable to conditions as specified.....		N/A
30.2.3	Appliances operated while unattended, tested as specified in 30.2.3.1 and 30.2.3.2		N/A
	The tests are not applicable to conditions as specified.....		N/A
30.2.3.1	Parts of non-metallic material supporting connections carrying a current exceeding 0,2 A during normal operation, and		P
	parts of non-metallic material, other than small parts, within a distance of 3 mm,		P
	subjected to the glow-wire test of IEC 60695-2-11 with a test severity of 850 °C	(See appended table)	P
	Glow-wire applied to an interposed shielding material, if relevant		N/A
	The glow-wire test is not carried out on parts of material classified as having a glow-wire flammability index according to IEC 60695-2-12 of at least 850 °C		N/A
30.2.3.2	Parts of non-metallic material supporting connections, and		P
	parts of non-metallic material within a distance of 3mm,		P
	subjected to glow-wire test of IEC 60695-2-11		P

IEC 60335-2-25			
Clause	Requirement - Test	Result - Remark	Verdict
	The test severity is:		--
	- 750 °C, for connections carrying a current exceeding 0,2 A during normal operation	(See appended table)	P
	- 650 °C, for other connections	(See appended table)	P
	Glow-wire applied to an interposed shielding material, if relevant		N/A
	However, the glow-wire test of 750 °C or 650 °C as appropriate, is not carried out on parts of material fulfilling both or either of the following classifications:		--
	- a glow-wire ignition temperature according to IEC 60695-2-13 of at least:		N/A
	<ul style="list-style-type: none"> • 775 °C, for connections carrying a current exceeding 0,2 A during normal operation 		N/A
	<ul style="list-style-type: none"> • 675 °C, for other connections 		N/A
	- a glow-wire flammability index according to IEC 60695-2-12 of at least:		N/A
	- 750 °C, for connections carrying a current exceeding 0,2 A during normal operation		N/A
	- 650 °C, for other connections		N/A
	The glow-wire test is also not carried out on small parts. These parts are to:		--
	- comprise material having a glow-wire ignition temperature of at least 775 °C or 675 °C as appropriate, or		N/A
	- comprise material having a glow-wire flammability index of at least 750 °C or 650 °C as appropriate, or		N/A
	- comply with the needle-flame test of Annex E, or		N/A
	- comprise material classified as V-0 or V-1 according to IEC 60695-11-10		N/A
	The consequential needle-flame test of Annex E applied to non-metallic parts that encroach within the vertical cylinder placed above the centre of the connection zone and on top of the non-metallic parts supporting current-carrying connections, and parts of non-metallic material within a distance of 3 mm of such connections if these parts are those:		--
	- parts that withstood the glow-wire test of IEC 60695-2-11 of 750 °C or 650 °C as appropriate, but produce a flame that persist longer than 2 s, or	(See appended table)	P
	- parts that comprised material having a glow-wire flammability index of at least 750 °C or 650 °C as appropriate, or		N/A
	- small parts, that comprised material having a glow-wire flammability index of at least 750 °C or 650 °C as appropriate, or		N/A

IEC 60335-2-25			
Clause	Requirement - Test	Result - Remark	Verdict
	- small parts for which the needle-flame test of Annex E was applied, or		N/A
	- small parts for which a material classification of V-0 or V-1 was applied		N/A
	However, the consequential needle-flame test is not carried out on non-metallic parts, including small parts, within the cylinder that are:		--
	- parts having a glow-wire ignition temperature of at least 775 °C or 675 °C as appropriate, or		N/A
	- parts comprising material classified as V-0 or V-1 according to IEC 60695-11-10, or		N/A
	- parts shielded by a flame barrier that meets the needle-flame test of Annex E or that comprises material classified as V-0 or V-1 according to IEC 60695-11-10		N/A
30.2.4	Base material of printed circuit boards subjected to the needle-flame test of Annex E	(See appended table)	P
	Test not applicable to conditions as specified.....:		N/A
31	RESISTANCE TO RUSTING		--
	Relevant ferrous parts adequately protected against rusting		P
	Tests specified in part 2 when necessary		N/A
32	RADIATION, TOXICITY AND SIMILAR HAZARDS		--
	Appliance does not emit harmful radiation or present a toxic or similar hazard due to their operation in normal use		P
	Test and measurement of microwave leakage according to specifications (IEC 60335-2-25)		P
	Appliance microwave leakage not exceed 50W/m ²	0,4 W/m ²	P
A	ANNEX A (INFORMATIVE) ROUTINE TESTS		--
	Description of routine tests to be carried out by the manufacturer		N/A
AA	ANNEX AA (NORMATIVE) REQUIREMENTS FOR COMBINATION MICROWAVE OVENS (IEC 60335-2-25)		--
AA.7.12	Warning: When the appliance is operated in the combination mode, children should only use the oven under adult supervision due to the temperatures generated.		N/A
AA.11.7	Microwave oven having conventional heating means that can be operated simultaneously:		N/A
	- microwave power		N/A

IEC 60335-2-25			
Clause	Requirement - Test	Result - Remark	Verdict
	- test duration		N/A
AA.18.	Additional conditioning carried out: resistive element operated:		N/A
	15 min if radiant heating		N/A
	30 min if convection heating		N/A
	Pyrolytic self-cleaning (one cycle)		N/A
AA.19.1	Test of 19.102 performed at 1,06 times rated voltage		N/A
AA.22	22.120 of IEC 60335-2-6:2014 is not applicable.		N/A
AA.29.2	the insulation is exposed to exhaust air from the oven cavity, in which case pollution degree 3 applies		N/A
AA.29.3	There are no thickness requirements for sheaths of visibly glowing heating elements if the door interlocks provide all-pole disconnection		N/A
B	ANNEX B (NORMATIVE) APPLIANCES POWERED BY RECHARGEABLE BATTERIES THAT ARE RECHARGED IN THE APPLIANCE		--
	The following modifications to this standard are applicable for appliances powered by batteries that are recharged in the appliance		N/A
	This annex does not apply to battery chargers		N/A
3.1.9	Appliance operated under the following conditions:		--
	- the appliance, supplied by its fully charged battery, operated as specified in relevant part 2		N/A
	- the battery is charged, the battery being initially discharged to such an extent that the appliance cannot operate		N/A
	-if possible, the appliance is supplied from the supply mains through its battery charger, the battery being initially discharged to such an extent that the appliance cannot operate. The appliance is operated as specified in relevant part 2		N/A
	- if the appliance incorporates inductive coupling between two parts that are detachable from each other, the appliance is supplied from the supply mains with the detachable part removed		N/A
3.6.2	Part to be removed in order to discard the battery is not considered to be detachable		N/A
5.B.101	Appliances supplied from the supply mains tested as specified for motor-operated appliances		N/A
7.1	Battery compartment for batteries intended to be replaced by the user, marked with battery voltage and polarity of the terminals		N/A

IEC 60335-2-25			
Clause	Requirement - Test	Result - Remark	Verdict
	The positive terminal indicated by symbol IEC 60417-5005 and the negative terminal by symbol IEC 60417-5006		N/A
	Appliances intending to be supplied from a detachable supply unit marked with symbol IEC 60417-6181 and its type reference along with symbol ISO 7000-0790 (2004-01), or		N/A
	use only with <model designation> supply unit :		N/A
7.6	Additional symbols		N/A
7.12	The instructions give information regarding charging		N/A
	The instructions for appliances incorporating batteries intended to be replaced by the user includes required information		N/A
	Details about how to remove batteries containing materials hazardous to the environment given		N/A
	For appliances intending to be supplied from a detachable supply unit for the purposes of recharging the battery, the type reference of the detachable supply unit is stated along with the following:		--
	WARNING: For the purposes of recharging the battery, only use the detachable supply unit provided with this appliance		N/A
	If the symbol for detachable supply unit is used, its meaning is explained		N/A
7.15	Markings placed on the part of the appliance connected to the supply mains		N/A
	The type reference of the detachable supply unit is placed in close proximity to the symbol		N/A
8.2	Appliances having batteries that according to the instruction may be replaced by the user need only have basic insulation between live parts and the inner surface of the battery compartment		N/A
	If the appliance can be operated without batteries, double or reinforced insulation required		N/A
11.7	The battery is charged for the period stated in the instructions or 24 h		N/A
11.8	Temperature rise of the battery surface does not exceed the limit in the battery manufacturer's specification; measured (K); limit (K)		N/A
	If no limit specified, the temperature rise does not exceed 20 K; measured (K)		N/A
19.1	Appliances subjected to tests of 19.B.101, 19.B.102 and 19.B.103		N/A

IEC 60335-2-25			
Clause	Requirement - Test	Result - Remark	Verdict
19.10	Not applicable		N/A
19.B.101	Appliances supplied at rated voltage for 168 h, the battery being continually charged		N/A
19.B.102	For appliances having batteries that can be removed without the aid of a tool, short-circuit of the terminals of the battery, the battery being fully charged,		N/A
19.B.103	Appliances having batteries replaceable by the user supplied at rated voltage under normal operation with the battery removed or in any position allowed by the construction		N/A
19.13	The battery does not rupture or ignite		N/A
21.B.101	Appliances having pins for insertion into socket-outlets have adequate mechanical strength		N/A
	Part of the appliance incorporating the pins subjected to the free fall test, procedure 2, of IEC 60068-2-31, the number of falls being:		--
	- 100, if the mass of the part does not exceed 250 g (g).....:		N/A
	- 50, if the mass of the part exceeds 250 g		N/A
	After the test, the requirements of 8.1, 15.1.1, 16.3 and clause 29 are met		N/A
22.3	Appliances having pins for insertion into socket-outlets tested as fully assembled as possible		N/A
25.13	An additional lining or bushing not required for interconnection cords in class III appliances or class III constructions operating at safety extra-low voltage not containing live parts		N/A
30.2	For parts of the appliance connected to the supply mains during the charging period, 30.2.3 applies		N/A
	For other parts, 30.2.2 applies		N/A
BB	ANNEX BB (normative) MICROWAVE OVENS INTENDED TO BE USED ON BOARD SHIP (IEC 60335-2-25)		--
BB.7.1	– rated frequency or rated frequency range in Hz;		N/A
BB.7.12	The instructions for use shall also include the substance of the following		--
	– usage on board ships; – installation place (open deck protective enclosure, dayrooms); – fastening means.		N/A

IEC 60335-2-25			
Clause	Requirement - Test	Result - Remark	Verdict
	The instructions for microwave ovens that are intended to be used on board ships shall state: CAUTION: Verify that the voltage and frequency of the mains supply of the ship matches the rated voltage and rated frequency or rated frequency range of the microwave oven.		N/A
BB.22 22.BB.101	Appliances shall withstand the pulses to which they may be subjected Compliance is checked by carrying out the half-sine pulse tests specified in IEC 60068-2-27 under the following conditions. The appliance is fastened in its normal position of use to a shock-testing machine by means of straps around the enclosure. The type of pulse is a half-sine pulse and the severity is as follows. - application of the half-sine pulse is in all 3 axes; - peak acceleration: 250 m/s ² , - duration of each half-sine pulse: 6 ms; - number of half-sine pulses in each direction: 1 000±10.		N/A
	The appliance shall show no damage that could impair compliance with 8.1, 16.3, Clause 29 and Clause 32, and connections shall not have worked loose.		N/A
22.BB.102	Appliances shall withstand the vibrations to which they may be subjected. Compliance is checked by carrying out the vibration tests specified in IEC 60068-2-6 under the following conditions. The appliance is fastened in its normal position of use upon a vibration table by means of straps around the enclosure. The type of vibration is sinusoidal and the severity is as follows: – direction of vibration is vertical and horizontal; – amplitude of vibration: 0,35 mm; – sweep frequency range: 10 Hz to 150 Hz; – duration of the test: 30 min.		N/A
	The appliance shall show no damage that could impair compliance with 8.1, 16.3, Clause 29 and Clause 32, and connections shall not have worked loose.		N/A
BB.31	Compliance is checked by the salt mist test Kb of IEC 60068-2-52,		N/A
	– for open deck use severity 1 is applicable;		N/A
	– for dayrooms use severity 2 is applicable		N/A

IEC 60335-2-25			
Clause	Requirement - Test	Result - Remark	Verdict
	After the test, the appliance shall not have deteriorated to such an extent that compliance with this standard, in particular with Clauses 8 and 27, is impaired. The coating shall not be broken and shall not have detached from the metal surface.		N/A
C	ANNEX C (NORMATIVE) AGEING TEST ON MOTORS		--
	Tests, as described, carried out when doubt with regard to the temperature classification of the insulation of a motor winding		N/A
	Test conditions as specified		N/A
D	ANNEX D (NORMATIVE) THERMAL MOTOR PROTECTORS		--
	Applicable to appliances having motors that incorporate thermal motor protectors necessary for compliance with the standard		N/A
	Test conditions as specified		N/A
E	ANNEX E (NORMATIVE) NEEDLE-FLAME TEST		--
	Needle-flame test carried out in accordance with IEC 60695-11-5, with the following modifications:		--
7	Severities		--
	The duration of application of the test flame is 30 s ± 1 s		P
9	Test procedure		--
9.1	The specimen so arranged that the flame can be applied to a vertical or horizontal edge as shown in the examples of Figure 1		P
9.2	The first paragraph does not apply		P
	If possible, the flame is applied at least 10 mm from a corner		P
9.3	The test is carried out on one specimen		P
	If the specimen does not withstand the test, the test may be repeated on two additional specimens, both withstanding the test		N/A
11	Evaluation of test results		--
	The duration of burning not exceeding 30 s		N/A
	However, for printed circuit boards, the duration of burning not exceeding 15 s		P
F	ANNEX F (NORMATIVE) CAPACITORS		--

IEC 60335-2-25			
Clause	Requirement - Test	Result - Remark	Verdict
	Capacitors likely to be permanently subjected to the supply voltage, and used for radio interference suppression or voltage dividing, comply with the following clauses of IEC 60384-14, with the following modifications:		--
1.5	Terms and definitions		--
1.5.3	Class X capacitors tested according to subclass X2		N/A
1.5.4	This subclause is applicable		N/A
1.6	Marking		--
	Items a) and b) are applicable		N/A
3.4	Approval testing		--
3.4.3.2	Table 3 is applicable as described		N/A
4.1	Visual examination and check of dimensions		--
	This subclause is applicable		N/A
4.2	Electrical tests		--
4.2.1	This subclause is applicable		N/A
4.2.5	This subclause is applicable		N/A
4.2.5.2	Only table 11 is applicable		N/A
	Values for test A apply		N/A
	However, for capacitors in heating appliances the values for test B or C apply		N/A
4.12	Damp heat, steady state		--
	This subclause is applicable		N/A
	Only insulation resistance and voltage proof are checked		N/A
4.13	Impulse voltage		--
	This subclause is applicable		N/A
4.14	Endurance		--
	Subclauses 4.14.1, 4.14.3, 4.14.4 and 4.14.7 are applicable		N/A
4.14.7	Only insulation resistance and voltage proof are checked		N/A
	No visible damage		N/A
4.17	Passive flammability test		--
	This subclause is applicable		N/A
4.18	Active flammability test		--
	This subclause is applicable		N/A
G	ANNEX G (NORMATIVE) SAFETY ISOLATING TRANSFORMERS		--

IEC 60335-2-25			
Clause	Requirement - Test	Result - Remark	Verdict
	The following modifications to this standard are applicable for safety isolating transformers:		--
7	Marking and instructions		--
7.1	Transformers for specific use marked with:		--
	-name, trademark or identification mark of the manufacturer or responsible vendor.....:		N/A
	-model or type reference.....:		N/A
17	Overload protection of transformers and associated circuits		--
	Fail-safe transformers comply with subclause 15.5 of IEC 61558-1		N/A
22	Construction		--
	Subclauses 19.1 and 19.1.2 of IEC 61558-2-6 are applicable		N/A
29	Clearances, creepage distances and solid insulation		--
29.1, 29.2, 29.3	The distances specified in items 2a, 2c and 3 in table 13 of IEC 61558-1 apply		N/A
	For insulated winding wires complying with subclause 19.12.3 of IEC 61558-1 there are no requirements for clearances or creepage distances		N/A
	For windings providing reinforced insulation, the distance specified in item 2c of table 13 of IEC 61558-1 is not assessed		N/A
	For safety isolating transformers subjected to periodic voltages with a frequency exceeding 30 kHz, the clearances, creepage distances and solid insulation values specified in IEC 60664-4 are applicable, if greater than the values specified in items 2a, 2c and 3 in table 13 of IEC 61558-1		N/A
H	ANNEX H (NORMATIVE) SWITCHES		--
	Switches comply with the following clauses of IEC 61058-1, as modified below:		--
	The tests of IEC 61058-1 carried out under the conditions occurring in the appliance		N/A
	Before being tested, switches are operated 20 times without load		N/A
8	Marking and documentation		--
	Switches are not required to be marked		N/A
	However, a switch that can be tested separately from the appliance marked with the manufacturer's name or trade mark and the type reference		N/A
13	Mechanism		--

IEC 60335-2-25			
Clause	Requirement - Test	Result - Remark	Verdict
	The tests may be carried out on a separate sample		N/A
15	Insulation resistance and dielectric strength		--
15.1	Not applicable		N/A
15.2	Not applicable		N/A
15.3	Applicable for full disconnection and micro-disconnection		N/A
17	Endurance		--
	Compliance is checked on three separate appliances or switches		N/A
	For 17.2.4.4, the number of cycles declared according to 7.1.4 is 10 000, unless		N/A
	otherwise specified in 24.1.3 of the relevant part 2 of IEC 60335		N/A
	Switches for operation under no load and which can be operated only by a tool, and		N/A
	switches operated by hand that are interlocked so that they cannot be operated under load,		N/A
	are not subjected to the tests		N/A
	However, switches without this interlock are subjected to the test of 17.2.4.4 for 100 cycles of operation		N/A
	Subclauses 17.2.2 and 17.2.5.2 not applicable		N/A
	The ambient temperature during the test is that occurring in the appliance during the test of Clause 11 in IEC 60335-1		N/A
	The temperature rise of the terminals not more than 30 K above the temperature rise measured in clause 11 of IEC 60335-1 (K).....		N/A
20	Clearances, creepage distances, solid insulation and coatings of rigid printed board assemblies		--
	Clause 20 is applicable to clearances across full disconnection and micro-disconnection		N/A
	It is also applicable to creepage distances for functional insulation, across full disconnection and micro-disconnection, as stated in Table 24		N/A
I	ANNEX I (NORMATIVE) MOTORS HAVING BASIC INSULATION THAT IS INADEQUATE FOR THE RATED VOLTAGE OF THE APPLIANCE		--
	The following modifications to this standard are applicable for motors having basic insulation that is inadequate for the rated voltage of the appliance:		--
8	Protection against access to live parts		--

IEC 60335-2-25			
Clause	Requirement - Test	Result - Remark	Verdict
8.1	Metal parts of the motor are considered to be bare live parts		N/A
11	Heating		--
11.3	The temperature rise of the body of the motor is determined instead of the temperature rise of the windings		N/A
11.8	The temperature rise of the body of the motor, where in contact with insulating material, not exceeding values in table 3 for the relevant insulating material		N/A
16	Leakage current and electric strength		--
16.3	Insulation between live parts of the motor and its other metal parts is not subjected to the test		N/A
19	Abnormal operation		--
19.1	The tests of 19.7 to 19.9 are not carried out		N/A
19.I.101	Appliance operated at rated voltage with each of the following fault conditions:		--
	- short circuit of the terminals of the motor, including any capacitor incorporated in the motor circuit		N/A
	- short circuit of each diode of the rectifier		N/A
	- open circuit of the supply to the motor		N/A
	- open circuit of any parallel resistor, the motor being in operation		N/A
	Only one fault simulated at a time, the tests carried out consecutively		N/A
22	Construction		--
22.I.101	For class I appliances incorporating a motor supplied by a rectifier circuit, the d.c. circuit being insulated from accessible parts of the appliance by double or reinforced insulation		N/A
	Compliance checked by the tests specified for double and reinforced insulation		N/A
J	ANNEX J (NORMATIVE) COATED PRINTED CIRCUIT BOARDS		--
	Testing of protective coatings of printed circuit boards carried out in accordance with IEC 60664-3 with the following modifications:		--
5.7	Conditioning of the test specimens		--
	When production samples are used, three samples of the printed circuit board are tested		N/A
5.7.1	Cold		--
	The test is carried out at -25 °C		N/A

IEC 60335-2-25			
Clause	Requirement - Test	Result - Remark	Verdict
5.7.3	Rapid change of temperature		--
	Severity 1 is specified		N/A
5.9	Additional tests		--
	This subclause is not applicable		N/A
K	ANNEX K (NORMATIVE) OVERVOLTAGE CATEGORIES		--
	The information on overvoltage categories is extracted from IEC 60664-1		P
	Overvoltage category is a numeral defining a transient overvoltage condition		P
	Equipment of overvoltage category IV is for use at the origin of the installation		N/A
	Equipment of overvoltage category III is equipment in fixed installations and for cases where the reliability and the availability of the equipment is subject to special requirements		N/A
	Equipment of overvoltage category II is energy consuming equipment to be supplied from the fixed installation		P
	If such equipment is subjected to special requirements with regard to reliability and availability, overvoltage category III applies		N/A
	Equipment of overvoltage category I is equipment for connection to circuits in which measures are taken to limit transient overvoltages to an appropriate low level		N/A
L	ANNEX L (INFORMATIVE) GUIDANCE FOR THE MEASUREMENT OF CLEARANCES AND CREEPAGE DISTANCES		--
	Information for the determination of clearances and creepage distances		P
M	ANNEX M (NORMATIVE) POLLUTION DEGREE		--
	The information on pollution degrees is extracted from IEC 60664-1		P
	Pollution		--
	The microenvironment determines the effect of pollution on the insulation, taking into account the macroenvironment		P
	Means may be provided to reduce pollution at the insulation by effective enclosures or similar		P
	Minimum clearances specified where pollution may be present in the microenvironment		P

IEC 60335-2-25			
Clause	Requirement - Test	Result - Remark	Verdict
	Degrees of pollution in the microenvironment		--
	For evaluating creepage distances, the following degrees of pollution in the microenvironment are established:		--
	- pollution degree 1: no pollution or only dry, non-conductive pollution occurs. The pollution has no influence		N/A
	- pollution degree 2: only non-conductive pollution occurs, except that occasionally a temporary conductivity caused by condensation is to be expected		P
	- pollution degree 3: conductive pollution occurs or dry non-conductive pollution occurs that becomes conductive due to condensation that is to be expected		N/A
	- pollution degree 4: the pollution generates persistent conductivity caused by conductive dust or by rain or snow		N/A
N	ANNEX N (NORMATIVE) PROOF TRACKING TEST		--
	The proof tracking test is carried out in accordance with IEC 60112 with the following modifications:		--
7	Test apparatus		--
7.3	Test solutions		--
	Test solution A is used		P
10	Determination of proof tracking index (PTI)		--
10.1	Procedure		--
	The proof voltage is 100V, 175V, 400V or 600V ...:	175 V	P
	The test is carried out on five specimens		P
	In case of doubt, additional test with proof voltage reduced by 25V, the number of drops increased to 100		N/A
10.2	Report		--
	The report states if the PTI value was based on a test using 100 drops with a test voltage of (PTI-25) V		N/A
O	ANNEX O (INFORMATIVE) SELECTION AND SEQUENCE OF THE TESTS OF CLAUSE 30		--
	Description of tests for determination of resistance to heat and fire		P
P	ANNEX P (INFORMATIVE) GUIDANCE FOR THE APPLICATION OF THIS STANDARD TO APPLIANCES USED IN WARM DAMP EQUABLE CLIMATES		--

IEC 60335-2-25			
Clause	Requirement - Test	Result - Remark	Verdict
	Modifications applicable for class 0 and 01 appliances having a rated voltage exceeding 150V, intended to be used in countries having a warm damp equable climate and that are marked WDaE		--
	Modifications may also be applied to class 1 appliances having a rated voltage exceeding 150V, intended to be used in countries having a warm damp equable climate and that are marked WdaE, if liable to be connected to a supply mains that excludes the protective earthing conductor		--
5.7	The ambient temperature for the tests of clauses 11 and 13 is 40 +3/0 °C		N/A
7.1	The appliance marked with the letters WDaE		N/A
7.12	The instructions state that the appliance is to be supplied through a residual current device (RCD) having a rated residual operating current not exceeding 30 mA		N/A
	The instructions state that the appliance is considered to be suitable for use in countries having a warm damp equable climate, but may also be used in other countries		N/A
11.8	The values of Table 3 are reduced by 15 K		N/A
13.2	The leakage current for class I appliances not exceeding 0,5 mA		N/A
15.3	The value of t is 37 °C		N/A
16.2	The leakage current for class I appliances not exceeding 0,5 mA (mA):		N/A
19.13	The leakage current test of 16.2 is applied in addition to the electric strength test of 16.3		N/A
Q	ANNEX Q (INFORMATIVE) SEQUENCE OF TESTS FOR THE EVALUATION OF ELECTRONIC CIRCUITS		--
	Description of tests for appliances incorporating electronic circuits		P
R	ANNEX R (NORMATIVE) SOFTWARE EVALUATION		--
	Programmable electronic circuits requiring software incorporating measures to control the fault/error conditions specified in table R.1 or R.2 validated in accordance with the requirements of this annex		N/A
R.1	Programmable electronic circuits using software		--
	Programmable electronic circuits requiring software incorporating measures to control the fault/error conditions specified in table R.1 or R.2 constructed so that the software does not impair compliance with the requirements of this standard		N/A
R.2	Requirements for the architecture		--

IEC 60335-2-25			
Clause	Requirement - Test	Result - Remark	Verdict
	Programmable electronic circuits requiring software incorporating measures to control the fault/error conditions specified in table R.1 or R.2 use measures to control and avoid software-related faults/errors in safety-related data and safety-related segments of the software		N/A
R.2.1.1	Programmable electronic circuits requiring software incorporating measures to control the fault/error conditions specified in table R.2 have one of the following structures:		--
	- single channel with periodic self-test and monitoring		N/A
	- dual channel (homogenous) with comparison		N/A
	- dual channel (diverse) with comparison		N/A
	Programmable electronic circuits requiring software incorporating measures to control the fault/error conditions specified in table R.1 have one of the following structures:		--
	- single channel with functional test		N/A
	- single channel with periodic self-test		N/A
	- dual channel without comparison		N/A
R.2.2	Measures to control faults/errors		--
R.2.2.1	When redundant memory with comparison is provided on two areas of the same component, the data in one area is stored in a different format from that in the other area		N/A
R.2.2.2	Programmable electronic circuits with functions requiring software incorporating measures to control the fault/error conditions specified in table R.2 and that use dual channel structures with comparison, have additional fault/error detection means for any fault/errors not detected by the comparison		N/A
R.2.2.3	For programmable electronic circuits with functions requiring software incorporating measures to control the fault/error conditions specified in table R.1 or R.2, means are provided for the recognition and control of errors in transmissions to external safety-related data paths		N/A
R.2.2.4	For programmable electronic circuits with functions requiring software incorporating measures to control the fault/error conditions specified in table R.1 or R.2, the programmable electronic circuits incorporate measures to address the fault/errors in safety-related segments and data indicated in table R.1 and R.2 as appropriate		N/A

IEC 60335-2-25			
Clause	Requirement - Test	Result - Remark	Verdict
R.2.2.5	For programmable electronic circuits with functions requiring software incorporating measures to control the fault/error conditions specified in table R.1 or R.2, detection of a fault/error occur before compliance with clause 19 is impaired		N/A
R.2.2.6	The software is referenced to relevant parts of the operating sequence and the associated hardware functions		N/A
R.2.2.7	Labels used for memory locations are unique		N/A
R.2.2.8	The software is protected from user alteration of safety-related segments and data		N/A
R.2.2.9	Software and safety-related hardware under its control is initialized and terminates before compliance with clause 19 is impaired		N/A
R.3	Measures to avoid errors		--
R.3.1	General		--
	For programmable electronic circuits with functions requiring software incorporating measures to control the fault/error conditions specified in table R.1 or R.2, the following measures to avoid systematic fault in the software are applied		--
	Software that incorporates measures used to control the fault/error conditions specified in table R.2 is inherently acceptable for software required to control the fault/error conditions specified in table R.1		N/A
R.3.2	Specification		--
R.3.2.1	Software safety requirements:		N/A
	The specification of the software safety requirements includes the descriptions listed		N/A
R.3.2.2	Software architecture		--
R.3.2.2.1	The specification of the software architecture includes the aspects listed - techniques and measures to control software faults/errors (refer to R.2.2); - interactions between hardware and software; - partitioning into modules and their allocation to the specified safety functions; - hierarchy and call structure of the modules (control flow); - interrupt handling; - data flow and restrictions on data access; - architecture and storage of data; - time-based dependencies of sequences and data		N/A

IEC 60335-2-25			
Clause	Requirement - Test	Result - Remark	Verdict
R.3.2.2.2	The architecture specification is validated against the specification of the software safety requirements by static analysis		N/A
R.3.2.3	Module design and coding		--
R.3.2.3.1	Based on the architecture design, software is suitably refined into modules		N/A
	Software module design and coding is implemented in a way that is traceable to the software architecture and requirements		N/A
R.3.2.3.2	Software code is structured		N/A
R.3.2.3.3	Coded software is validated against the module specification by static analysis		N/A
	The module specification is validated against the architecture specification by static analysis		N/A
R.3.3.3	Software validation		--
	The software is validated with reference to the requirements of the software safety requirements specification		N/A
	Compliance is checked by simulation of:		--
	- input signals present during normal operation		N/A
	- anticipated occurrences		N/A
	- undesired conditions requiring system action		N/A

IEC 60335-2-25			
Clause	Requirement - Test	Result - Remark	Verdict

TABLE R.1 – GENERAL FAULT/ERROR CONDITIONS						
Component ¹⁾	Fault/error	Acceptable measures ^{2) 3)}	Definitions	Document reference for applied measure	Document reference for applied test	Verdict
1 CPU 1.1 Registers	Stuck at	Functional test, or periodic self-test using either: - static memory test, or - word protection with single bit redundancy	H.2.16.5 H.2.16.6 H.2.19.6 H.2.19.8.2			N/A
1.2 VOID						N/A
1.3 Programme counter	Stuck at	Functional test, or Periodic self-test, or Independent time-slot monitoring, or Logical monitoring of the programme sequence	H.2.16.5 H.2.16.6 H.2.18.10.4 H.2.18.10.2			N/A
2 Interrupt handling and execution	No interrupt or too frequent interrupt	Functional test, or time-slot monitoring	H.2.16.5 H.2.18.10.4			N/A
3 Clock	Wrong frequency (for quartz synchronized clock: harmonics/sub-harmonics only)	Frequency monitoring, or time slot monitoring	H.2.18.10.1 H.2.18.10.4			N/A
4. Memory 4.1 Invariable memory	All single bit faults	Periodic modified checksum, or multiple checksum, or word protection with single bit redundancy	H.2.19.3.1 H.2.19.3.2 H.2.19.8.2			N/A

IEC 60335-2-25						
Clause	Requirement - Test	Result - Remark			Verdict	
4.2 Variable memory	DC fault	Periodic static memory test, or word protection with single bit redundancy	H.2.19.6 H.2.19.8.2			N/A
4.3 Addressing (relevant to variable and invariable memory)	Stuck at	Word protection with single bit redundancy including the address	H.2.19.8.2			N/A
5 Internal data path	Stuck at DC fault	Word protection with single bit redundancy Comparison of redundant CPUs by either: - reciprocal comparison - independent hardware comparator	H.2.19.8.2 H.2.18.15 H.2.18.3			N/A
5.1 VOID						N/A
5.2 Addressing	Wrong address	Word protection with single bit redundancy including the address	H.2.19.8.2			N/A
6 External communication	Hamming distance 3	Word protection with multi-bit redundancy, or CRC – single work, or Transfer redundancy, or Protocol test	H.2.19.8.1 H.2.19.4.1 H.2.18.2.2 H.2.18.14			N/A
6.1 VOID						N/A
6.2 VOID						N/A

IEC 60335-2-25						
Clause	Requirement - Test			Result - Remark		Verdict
6.3 Timing	Wrong point in time Wrong sequence	Time-slot monitoring, or scheduled transmission Time-slot and logical monitoring, or Comparison of redundant communication channels by either: - reciprocal comparison - independent hardware comparator Logical monitoring, or time-slot monitoring, or Scheduled transmission (same options as for wrong point in time)	H.2.18.10. 4 H.2.18.18 H.2.18.10. 3 H.2.18.15 H.2.18.3 H.2.18.10. 2 H.2.18.10. 4 H.2.18.18			N/A
7 Input/output periphery	Fault conditions specified in 19.11.2	Plausibility check Comparison of redundant communication channels by either: - reciprocal comparison - independent hardware comparator	H.2.18.13 H.2.18.15 H.2.18.3			N/A
7.1 VOID						N/A
7.2 Analog I/O 7.2.1 A/D and D/A- converter	Fault conditions specified in 19.11.2	Plausibility check	H.2.18.13			N/A
7.2.2 Analog multiplexer	Wrong addressing	Plausibility check	H.2.18.13			N/A
8 VOID						N/A
9 Custom chips ⁴⁾ e.g. ASIC, GAL, Gate array	Any output outside the static and dynamic functional specification	Periodic self-test	H.2.16.6			N/A
NOTE A Stuck-at fault model denotes a fault model representing an open circuit or a non-varying signal level. A DC fault model denotes a stuck-at fault model incorporating short circuit between signal lines.						

IEC 60335-2-25			
Clause	Requirement - Test	Result - Remark	Verdict

- ¹⁾ For fault/error assessment, some components are divided into their sub-functions.
²⁾ For each sub-function in the table, the Table R.2 measure will cover the software fault/error.
³⁾ Where more than one measure is given for a sub-function, these are alternatives.
⁴⁾ To be divided as necessary by the manufacturer into sub-functions.

S	ANNEX S (NORMATIVE) BATTERY OPERATED APPLIANCES POWERED BY BATTERIES THAT ARE NON-RECHARGEABLE OR NOT RECHARGED IN THE APPLIANCE		--
	The following modifications to this standard are applicable for battery-operated appliances where the batteries are either non-rechargeable (primary batteries), or		N/A
	rechargeable batteries (secondary batteries) that are not recharged in the appliance		N/A
5.8.1	If the supply terminals for the connection of the battery have no indication of polarity, the more unfavourable polarity is applied		N/A
5.S.101	Appliances intended for use with a battery box are tested with the battery box supplied with the appliance or with the battery box recommended in the instructions		N/A
5.S.102	Appliances are tested as motor-operated appliances.		N/A
7.1	Appliances marked with the battery voltage (V) and the polarity of the terminals, unless		N/A
	the polarity is irrelevant		N/A
	Appliances also marked with:		--
	– name, trade mark or identification mark of the manufacturer or responsible vendor		N/A
	– model or type reference.....		N/A
	– IP number according to degree of protection against ingress of water, other than IPX0		N/A
	– type reference of battery or batteries.....		N/A
	If relevant, the positive terminal is indicated by the symbol IEC 60417-5005 and the negative terminal by the symbol IEC 60417-5006		N/A
	If appliances use more than one battery, they are marked to indicate correct polarity connection of the batteries		N/A
7.6	Additional symbols		N/A
7.12	The instructions contain the following, as applicable:		--
	– the types of batteries that may be used.....		N/A

IEC 60335-2-25			
Clause	Requirement - Test	Result - Remark	Verdict
	– how to remove and insert the batteries		N/A
	– non-rechargeable batteries are not to be recharged		N/A
	– rechargeable batteries are to be removed from the appliance before being charged		N/A
	– different types of batteries or new and used batteries are not to be mixed		N/A
	– batteries are to be inserted with the correct polarity		N/A
	– exhausted batteries are to be removed from the appliance and safely disposed of		N/A
	– if the appliance is to be stored unused for a long period, the batteries are removed		N/A
	– the supply terminals are not to be short-circuited		N/A
11.5	Appliances are supplied with the most unfavourable supply voltage between		--
	– 0,55 and 1,0 times the battery voltage, if the appliance can be used with non-rechargeable batteries		N/A
	– 0,75 and 1,0 times battery voltage, if the appliance is designed for use with rechargeable batteries only		N/A
	The values specified in Table S.101 for the internal resistance per cell of the battery is taken into account		N/A
19.1	The tests are carried out with the battery fully charged unless otherwise specified		N/A
19.13	The battery does not rupture or ignite		N/A
19.S.101	Appliances are supplied with the voltage specified in 11.5. The supply terminals having an indication of polarity are connected to the opposite polarity, unless		N/A
	such a connection is unlikely to occur due to the construction of the appliance		N/A
19.S.102	For appliances with provision for multiple batteries, one or more of the batteries are reversed and the appliance is operated, if reversal of batteries is allowed by the construction		N/A
25.5	The flexible leads or flexible cord used to connect an external battery or battery box in is connected to the appliance by a type X attachment		N/A
25.13	This requirement is not applicable to the flexible leads or flexible cord connecting external batteries or a battery box with an appliance		N/A

IEC 60335-2-25			
Clause	Requirement - Test	Result - Remark	Verdict
25.S.101	Appliances have suitable means for connection of the battery. If the type of battery is marked on the appliance, the means of connection is suitable for this type of battery		N/A
26.5	Terminal devices in an appliance for the connection of the flexible leads or flexible cord connecting an external battery or battery box are so located or shielded that there is no risk of accidental connection between supply terminals		N/A
30.2.3.2	There is no battery in the area of the vertical cylinder used for the consequential needle flame test, unless		N/A
	the battery is shielded by a barrier that meets the needle flame test of Annex E, or		N/A
	that comprises material classified as V-0 or V-1 according to IEC 60695-11-10		N/A

10.1	TABLE: Power input deviation					P
Input deviation of/at:	P rated (W)	P measured (W)	dP (W, %)	Required dP (W, %)	Remark	
235 V, 50 Hz	1100	1174	+6,7%	+15%	P70T20AL-V2A	
235 V, 50 Hz	1100	1171	+1,9%	+15%	P70T20L-V1A	
Supplementary information: --						

10.2	TABLE: Current deviation					N/A
Current deviation of/at:	I rated (A)	I measured (A)	dI (A, %)	Required dI (A, %)	Remark	
Supplementary information: --						

11.8 a	TABLE: Heating test, thermocouple measurements for model P70T20L-V1A		P
	Test voltage (V)..... :	254,4	—
	Ambient (°C)..... :	22,3 / 22,5	—
Thermocouple locations	Max. temperature rise measured, dT (K)	Max. temperature rise limit, dT (K)	
HF transformer winding	45,7	85, Class 130	
Opto-coupler	41,8	T100-25=75	
Relay ambient	49,4	T85-25=60	
PCB	44,6	120	
Interlock switch	52,4	T105-25=80	
Lampholder	97,6	T170-25=145	
Cavity thermal cut-out	65,9	Ref.	
H,V, transformer primary winding	160,7	180, Class 220	
H,V, transformer thermal protector	144,7	Ref..	
Fan motor winding	51,5	85, Class 130	
Turntable motor winding	53,7	80, Class 120	
Power cord	35,7	50	
Plastic supporting H,V, fuse	48,3	For clause 30.1	
High volatge capacitor	39,2	T85-25=60	
X2 capacitor on Noise filter board	45,4	T100-25=75	
Y capacitor on Noise filter board	44,5	T85-25=60	
Plastic supporting fan motor	52,9	For clause 30.1	
Internal wire of VPC	70,9	T105-25=80	
Internal wire of HV transformer	51,5	T230-25=205	

Metal surface	37,2	59
Window	13,5	65
Door handle	9,1	35
Surface of the panel plastic	13,7	74
Button on control panel	9,4	74
Internal surface of the panel plastic	36,8	For clause 30.1
Test corner (right)	24,6	65
Test corner (back)	32,4	65
Test corner (bottom)	26,3	65
Test corner (top)	14,2	65

11.8 a	TABLE: Heating test, resistance method for model P70T20L-V1A					P
Temperature rise of winding	R1 (Ω)	R2 (Ω)	dT (K)	Max. dT (K)	Insulation class	
Fan motor winding	401,2	493,7	59,0	95	130	
Turntable motor winding	284,8	352,9	61,2	90	120	
HV transformer Pri. Winding	2,78	4,74	174,2	180	220	
HV transformer Sec. Winding	232,8	399,80	177,2	180	220	

11.8 b	TABLE: Heating test, thermocouple measurements for model P70T20AL-V2A		P
	Test voltage (V)..... :	254,4	—
	Ambient ($^{\circ}\text{C}$)..... :	22,3 / 22,5	—
Thermocouple locations	Max. temperature rise measured, dT (K)	Max. temperature rise limit, dT (K)	
Timer ambient	58,8	T90-25=65	
Internal surface of the panel plastic	49,8	For clause 30.1	
Power cord (inside)	41,8	50	
High voltage capacitor	49,2	T85-25=60	
Plastic supporting H,V, fuse	51,9	For clause 30.1	
Lamp holder	118,3	T170-25=145	
Cavity thermal cut-out	69,9	Ref.	
Interlock switch(middle one)	62,2	T105-25=80	
Magnetron metal cover (near the internal wire)	71,9	Ref.	
Fan motor winding	57,4	85, Class 130	
Turntable motor winding	61,1	80, Class 120	
H,V, transformer primary winding	157,3	180, Class 220	
H,V, transformer Thermal Protector	133,7	Ref.	

Internal wire for VPC	56,0	T105-25=80
Internal wire for H,V, transformer	62,5	T230-25=205
X2 capacitor on Noise filter board	56,6	T100-25=75
Y capacitor on Noise filter board	52,2	T85-25=60
Plastic supporting door-switch system	56,7	For clause 30.1
Plastic supporting fan motor	45,5	For clause 30.1
Window	26,1	65
Metal surface	40,2	59
Test corner (back)	31,5	65
Test corner (bottom)	38,0	65
Test corner (right side)	26,0	65
Test corner (top)	15,4	65

11.8 b	TABLE: Heating test, resistance method for model P70T20AL-V2A					P
Temperature rise of winding	R1 (Ω)	R2 (Ω)	dT (K)	Max. dT (K)	Insulation class	
Fan motor winding	402,0	503,9	64,9	95	130	
Turntable motor winding	287,4	364,4	68,6	90	120	
HV transformer Pri. Winding	3,01	5,09	170,8	180	220	
HV transformer Sec. Winding	213,35	364,72	174,8	180	220	

13.2	TABLE: Leakage current			P
	Heating appliances: 1.15 x rated input (W)..... :	--		—
	Motor-operated and combined appliances: 1.06 x rated voltage (V)	1,06 x 240 V = 254,4 V		—
Leakage current between		I (mA)	Max. allowed I (mA)	
Live part and earthed metal part		0,326	0,75	
Live part and control panel		0,017	0,35 (peak)	
Supplementary information:				

13.3	TABLE: Electric strength		P
Test voltage applied between:		Voltage (V)	Breakdown (Yes/No)
Live part and earthed metal part		1000	No
Live part and control panel		3000	No
Supplementary information: --			

14	TABLE: Transient overvoltages					N/A
Clearance between:	CI (mm)	Required CI (mm)	Rated impulse voltage (V)	Impulse test voltage (V)	Flashover (Yes/No)	
Supplementary information: --						

16.2	TABLE: Leakage current			P
	Single phase appliances: 1.06 x rated voltage (V)		1,06 x 240 V = 254,4 V	—
	Three phase appliances 1.06 x rated voltage divided by $\sqrt{3}$ (V)		--	—
Leakage current between		I (mA)	Max. allowed I (mA)	
Live part and earthed metal part		0,356	0,75	
Live part and control panel		0,056	0,25	
Supplementary information: --				

16.3	TABLE: Electric strength		P
Test voltage applied between:		Voltage (V)	Breakdown (Yes/No)
Live part and earthed metal part		1250	No
Live part and control panel		3000	No
Supplementary information: --			

17	TABLE: Overload protection, thermocouple measurements		P
Temperature rise of part/at:		dT (K)	Max. dT (K)
H,F, transformer winding		12,4	150, Class 130
Supplementary information: --			

17	TABLE: Overload protection, resistance method					N/A
	Test voltage (V).....					—
	Ambient, t1 (°C).....					—
	Ambient, t2 (°C).....					—
Temperature of winding		R1 (Ω)	R2 (Ω)	dT (K)	T (°C)	Max. T (°C)
Supplementary information: --						

19		Abnormal operation conditions					P
Operational characteristics		YES/NO	Operational conditions				
Are there electronic circuits to control the appliance operation?		Yes	--				
Are there "off" or "stand-by" position?		Yes	Off position				
The unintended operation of the appliance results in dangerous malfunction?		No	--				
Sub-clause	Operating conditions description	Test results description	PEC description	EMP 19.11.4	Software type required	19.11.3 PEC	Final result
19.2	--	--	--	--	--	--	--
19.3	--	--	--	--	--	--	--
19.4	--	--	--	--	--	--	--
19.5	--	--	--	--	--	--	--
19.6	--	--	--	--	--	--	--
19.7	--	--	--	--	--	--	--
19.8	--	--	--	--	--	--	--
19.9	--	--	--	--	--	--	--
19.10	--	--	--	--	--	--	--
19.11.2	See clause 19.11.2	No hazard	--	--	--	--	Pass
19.11.4.8	--	--	--	--	--	--	--
19.14	1,06 times rated voltage relay shorted.	No hazard	--	--	--	--	Pass
19.101	Rated voltage empty	No hazard	--	--	--	--	Pass
19.102	Rated voltage short timer	No hazard	--	--	--	--	Pass
19.103	Rated voltage lock motor, block air-opening	No hazard	--	--	--	--	Pass
Supplementary information: --							

19.7	TABLE: Abnormal operation, locked rotor/moving parts					N/A
	Test voltage (V).....:					—
	Ambient, t1 (°C).....:					—
	Ambient, t2 (°C).....:					—
Temperature of winding	R1 (Ω)	R2 (Ω)	dT (K)	T (°C)	Max. T (°C)	
Supplementary information: --						

19.9	TABLE: Abnormal operation, running overload					N/A
	Test voltage (V).....:					—
	Ambient, t1 (°C).....:					—
	Ambient, t2 (°C).....:					—
Temperature of winding	R1 (Ω)	R2 (Ω)	dT (K)	T (°C)	Max. T (°C)	
Supplementary information: --						

19.13 a	TABLE: Abnormal operation, temperature rises for model P70T20AL-V2A									P
Thermocouple locations	Max. temperature rise measured, dT (K)									Max. temperature rise limit, dT (K)
	19.11.2	19.10.1	19.10.2	19.14	19.10.3a	19.10.3b	19.10.3c	19.10.3d	19.10.3e	
H,F, transformer winding	27,0	59,0	68,7	65,8	63,6	60,3	54,8	39,3	52,6	150, Class 130
Opto-coupler	24,9	56,4	64,7	61,6	62,0	56,9	51,6	37,6	51,7	T100-25=70
H,V, transformer primary winding	99,0	99,5	143,9	142,4	155,5	102,1	116,7	129,6	113,6	225, Class 220
Fan motor winding	36,5	50,8	60,0	57,9	95,5	36,3	46,6	83,8	66,2	150, Class 130
Turntable motor winding	46,0	45,1	70,5	69,5	50,6	51,9	56,3	27,0	55,6	140, Class 120
Power cord	27,8	52,3	57,4	55,8	75,0	44,2	62,5	67,0	69,3	150
Internal surface of the panel plastic	25,8	45,1	48,2	46,5	49,2	37,6	47,9	24,9	32,6	For clause 30.1
Test corner	31,8	36,7	49,2	46,9	30,3	37,9	34,3	35,0	36,4	150
Supplementary information:										
Test 19.11.2: Tested with H,V, Diode was short-circuited, and the sample has not install with H,V, fuse.										
Test 19.103 a: Tested with air-inlet of rear was blocked.										
Test 19.103 b: Tested with air-outlet of bottom was blocked.										
Test 19.103 c: Tested with air-outlet of left was blocked.										
Test 19.103 d: Tested with fan motor was locked.										
Test 19.103 e: Tested with turntable motor was blocked.										

19.13 b	TABLE: Abnormal operation, temperature rises for model P70T20L-V1A									P
Thermocouple locations	Max. temperature rise measured, dT (K)									Max. temperature rise limit, dT (K)
	19.11.2	19.10.1	19.10.2	19.14	19.10.3a	19.10.3b	19.10.3c	19.10.3d	19.10.3e	
H,V, transformer primary winding	95,7	96,6	142,6	139,8	156,2	111,8	109,4	127,2	131,4	225, Class 220
Fan motor winding	34,5	49,0	59,9	58,5	106,7	38,3	49,9	85,5	42,6	150, Class 130
Turntable motor winding	38,5	45,3	70,4	68,8	40,0	56,0	63,8	27,6	53,3	140, Class 120
Power cord	26,8	52,6	57,3	56,5	74,6	45,7	74,3	70,8	64,5	145
Internal surface of the panel plastic	23,8	43,5	48,1	47,4	55,4	43,8	57,5	25,6	39,8	For clause 30.1
Test corner	26,7	33,8	49,1	47,5	21,1	28,7	44,6	43,6	30,6	150
Supplementary information: Test 19.11.2: Tested with H,V, Diode was short-circuited, and the sample has not install with H,V, fuse. Test 19.103 a: Tested with air-inlet of rear was blocked. Test 19.103 b: Tested with air-outlet of bottom was blocked. Test 19.103 c: Tested with air-outlet of left was blocked. Test 19.103 d: Tested with fan motor was locked. Test 19.103 e: Tested with turntable motor was blocked.										

19.11.2 a	TABLE: Abnormal operation			P
Fault condition	Short circuit	Open circuit	Result	
b	---	H.V. diode	No microwave generate	
b	---	H.V. capacitor	No microwave generate	
c-1	H.V. capacitor	---	H,V, fuse link operated immediately after switches on in the microwave mode	
c-2	H.V. capacitor	---	Current fuse link operated immediately after switches on in the microwave mode	
d-1	H.V. diode	---	H,V, fuse link operated immediately after switches on in the microwave mode.	
d-2	H.V. diode	---	See table 19.13	
19.11.2 of IEC 60335-2-25	---	Cathode of magnetron	No microwave generate	
19.11.2 of IEC 60335-2-25	---	Anode of magnetron	No microwave generate	
19.11.2 of IEC 60335-2-25	Cathode of magnetron and anode of magnetron	--	No microwave generates	

Supplementary information:

Test c-1 and d-1: The sample has install with H,V, fuse.

Test c-2 and d-2: The sample has no install with H,V, fuse.

b denotes open circuit at the terminals of any component.

c denotes short circuit of capacitors,

d denotes short circuit of any two terminals of an electronic component.

19.11.2 b	TABLE: Abnormal operation for noise filter PCB			P
Fault condition	Short circuit	Open circuit	Result	
b	---	C4	Normal operation	
b	---	C2	Normal operation	
b	---	C1	Normal operation	
b	---	D1	The appliance cannot be operated.	
b	---	C5	Normal operation	
b	---	ZD1	Normal operation	
c	C5	---	Normal operation	
d	ZD1	---	Normal operation	
d	D1	---	The appliance cannot be operated.	

Supplementary information:

Appliance supplied at 240 V and operated in microwave mode.

b denotes open circuit at the terminals of any component.

c denotes short circuit of capacitors,

d denotes short circuit of any two terminals of an electronic component.

19.11.2 c	TABLE: Abnormal operation for control panel PCB			P
Fault condition	Short circuit	Open circuit	Result	
b	—	ZNR1	Normal operation	
b	—	D1	Normal operation	
b	—	D5	Normal operation	
b	—	D7	The appliance cannot be operated.	
b	—	C3	Normal operation	
b	—	C2	Conductor of PCB becomes open-circuited immediately. The test was repeated on a second sample, same result achieved.	
b	—	C5	Normal operation	
b	—	C1	The appliance cannot be operated.	
b	—	C6	The appliance cannot be operated.	
c	C3	—	The appliance cannot be operated.	
c	C2	—	The coil "L1" broke immediately after plugged in. The test was repeated on a second sample, same result achieved.	

c	C5	—	The appliance cannot be operated.
c	C1	—	Conductor of PCB becomes open-circuited immediately. The test was repeated on a second sample, same result achieved.
c	C6	—	The appliance cannot be operated.
d	ZNR1	—	Conductor of PCB becomes open-circuited immediately. The test was repeated on a second sample, same result achieved.
d	D1	—	Conductor of PCB becomes open-circuited immediately. The test was repeated on a second sample, same result achieved.
d	D5	—	The appliance cannot be operated.
d	D7	—	The appliance cannot be operated.
f	IC5	IC5	The appliance cannot be operated.
f	U1 (pin 5-8)	—	Conductor of PCB becomes open-circuited immediately. The test was repeated on a second sample, same result achieved.
f	—	U1 (pin 5)	The appliance cannot be operated.
f	U1 (pin 5-3)	—	The appliance cannot be operated.

Supplementary information: Appliance supplied at 240 V and operated in microwave mode.

b denotes open circuit at the terminals of any component.

c denotes short circuit of capacitors,

d denotes short circuit of any two terminals of an electronic component.

f denotes failure of microprocessors and integrated circuits except components such as thyristors and triacs.

24.1		TABLE: Components information				P
Object / part No,	Manufacturer / trademark	Type / model	Technical data	Standard	Mark(s) of conformity	
Fan motor	Galanz	GAL6309E(30)-ZD	AC 220 – 240 V, 50/60Hz, Class B	IEC/EN 60335-1 IEC/EN 60335-2-25	Tested with appliance	
Turntable motor	Galanz	SM-16T	AC 30 V, 50/60Hz, 3 W, Class E	IEC/EN 60335-1 IEC/EN 60335-2-25	Tested with appliance	
Timer (30 mins)	Galanz	TM30MU01E(30)	Motor: AC 30 V, 50 Hz, Contact: AC 250 V, 8 A, T90, 3E3	IEC 60730-2-7: 2008 IEC 60730-1: 2013 EN 60730-1: 2011 EN 60730-2-7: 2010	ITS 170720097GZ U-001	
High voltage capacitor	Ningbo Bicai Industry Co., Ltd.	CH85 21090	AC 2100 V, T85, 0,9uF, 50/60Hz	IEC 61270-1: 1996 EN 61270-1: 1996	VDE 138073	
Alt.	Anhui Juan kuang Electric Co.,Ltd	CH85	AC 2100 V, T85, 0,9uF, 50/60Hz	IEC 61270-1: 1996 EN 61270-1: 1996	VDE 40041452	

High voltage diode	Nantong Gaoxin Electronic Co.,Ltd	CL01-12	FVD:12 V, AFC: 350 mA RBV:12,5 KV	IEC/EN 60335-1 IEC/EN 60335-2-25	Tested with appliance
Alt.	Rugao Dachang Electronics Co.,Ltd	CL01-12	FVD: 12 V, AFC: 350 mA RBV: 12 KV	IEC/EN 60335-1 IEC/EN 60335-2-25	Tested with appliance
Alt.	Nantong Gaoxin Electronic Co.,Ltd	CL04-12	FVD:12 V, AFC: 450 mA, RBV:12 KV	IEC/EN 60335-1 IEC/EN 60335-2-25	Tested with appliance
Alt.	Rugao Dachang Electronics Co.,Ltd	CL04-12	FVD: 12 V, AFC: 450 mA, RBV: 12 KV	IEC/EN 60335-1 IEC/EN 60335-2-25	Tested with appliance
High voltage fuse	Shanghai Songshan Electronics Co., Ltd	GERF1-40	AC 5KV, 0,65 A	IEC 60127-1: 2006 IEC 60127-2: 2003 + A1: 2010 EN 60127-1: 2006 EN 60127-2: 2003 + A1: 2004	TÜV Rd J 50099362
Alt.	Shanghai Songshan Electronics Co., Ltd	GERF-IV	AC 5KV, 0,65 A	IEC 60127-1: 2006 IEC 60127-2: 2003 + A1: 2010 EN 60127-1: 2006 EN 60127-2: 2003 + A1: 2004	TÜV Rd J 50099362
Alt.	Dongguan Better Electronics Technology Co., Ltd.	HV or 722	AC 5KV, 0,65 A	IEC 60127-1: 2006 IEC 60127-2: 2003 + A1: 2010 EN 60127-1: 2006 EN 60127-2: 2003 + A1: 2004	TÜV Rd J 50136139
H.V. transformer	Galanz	GAL-700E-4	AC 230-240 V, 50Hz, Class 220	IEC/EN 60335-1 IEC/EN 60335-2-25	Tested with appliance
Thermal Protector on H.V. transformer (High voltage fuse and thermal Protector on H.V. transformer are mutually exclusive when it comes to application)	Jiangsu Yitong Control System Co., Ltd.	17AM***	AC 250 V, 10 A Tf170, 1E4	IEC 60730-1: 2013 IEC 60730-2-9: 2008 + A1: 2011 EN 60730-1: 2016 EN 60730-2-9: 2010	TUV Rd R 50286149
Alt.	ChangShu Xin DuAn Electric Co., Ltd	17AM-x	AC 250 V, 10 A Tf170, 1E4	IEC 60730-1: 2013 IEC 60730-2-9: 2008 + A1: 2011 EN 60730-1: 2016 EN 60730-2-9: 2010	TUV Rd R 50350788

Alt.	Jiangsu Yitong Control System Co., Ltd.	17AM***	AC 250 V, 10 A Tf180, 1E4	IEC 60730-1: 2013 IEC 60730-2-9: 2008 + A1: 2011 EN 60730-1: 2016 EN 60730-2-9: 2010	TUV Rd R 50286149
Lamp holder	Yuyao Changhong Electric Factory	E14-A	AC 250 V, 2 A, E14, T170	IEC 60238: 2004 + A1: 2008 EN 60238: 2004 + A1: 2008 + A2: 2011	VDE 40004460
Lamp and holder (Integrated lamp)	Deqing New Minghui Electric Lighting Co.,Ltd.	Z187	Holder: 250 V, 2 A Lamp: 230 V, 20 W	IEC/EN 60335-1 IEC/EN 60335-2-25	Tested with appliance
Alt.	Yuyao Jiahong Electric	Z187	Holder: 250 V, 2 A Lamp: 230 V, 20 W	IEC/EN 60335-1 IEC/EN 60335-2-25	Tested with appliance
Alt.	Deqing Dinghui Lighting Co.,Ltd.	F-E14	Holder: 250 V, 2 A Lamp: 230 V, 20 W	IEC/EN 60335-1 IEC/EN 60335-2-25	Tested with appliance
Alt.	Deqing Xnjiyuan Applince Lighting Co., Ltd.	F-E14	Holder: 250 V, 2 A Lamp: 230 V, 20 W	IEC/EN 60335-1 IEC/EN 60335-2-25	Tested with appliance
Magnetron	Galanz	M24FA-210A	PO: 520W FO: 2450- 2470MHz	IEC/EN 60335-1 IEC/EN 60335-2-25	Tested with appliance
Micro switch	Guangdong Galanz Enterprises Co., Ltd.	W-15-102C W-15-302C	AC 250 V, 15 A, T105, 5E4	IEC 61058-1: 2000 + A1: 2001 + A2: 2007 EN 61058-1: 2002 + A2: 2008	TUV Rd R 50181337
Alt.	Yueqing Tongda Wire Electric Factory	HK-14	AC 250 V, 16 A, T125, 5E4	IEC 61058-1: 2000 + A1: 2001 + A2: 2007 EN 61058-1: 2002 + A2: 2008	VDE 40027032
Alt.	Shanghai Qiaoh Industry Co., Ltd.	V-J	AC 250 V, 16 A, T125, 5E4	IEC 61058-1: 2000 + A1: 2001 + A2: 2007 EN 61058-1: 2002 + A2: 2008	UL ENEC- 00074-A3
Plastic Control Panel	CHI MEI corporation	ABS PA-777D	94HB	IEC/EN 60335-1 IEC/EN 60335-2-25	UL E56070 Tested with appliance
Alt.	LG CHEM LTD	ABS HI121H	94HB	IEC/EN 60335-1 IEC/EN 60335-2-25	UL E67171 Tested with appliance
Alt.	LG CHEM LTD	ABS AF312C	94-V0	IEC/EN 60335-1 IEC/EN 60335-2-25	UL E67171 Tested with appliance
Alt.	LG CHEM LTD	ABS AF327(&)	94-V0	IEC/EN 60335-1 IEC/EN 60335-2-25	UL E67171 Tested with appliance

Alt.	SILVER AGE ENGINEERING PLASTICS (DONGGUAN) CO LTD	ABS 3360	94-V0	IEC/EN 60335-1 IEC/EN 60335-2-25	UL E225348 Tested with appliance
Plastic door cover	CHI MEI corporation	ABS PA-777D	94HB	IEC/EN 60335-1 IEC/EN 60335-2-25	UL E56070 Tested with appliance
Alt.	LG CHEM LTD	ABS HI121H	94HB	IEC/EN 60335-1 IEC/EN 60335-2-25	UL E67171 Tested with appliance
Plastic material supporting micro switch	Guangzhou Keyuan Innovative Materials Co Ltd	PBT301-G20	94V-0	IEC/EN 60335-1 IEC/EN 60335-2-25	UL E201440 Tested with appliance
Alt.	Guangdong Rynon New Material Co.,Ltd	PBT-V3020	94V-0	IEC/EN 60335-1 IEC/EN 60335-2-25	UL E246958 Tested with appliance
Alt.	Guang Dong High & New Plastic Co Ltd	PBT FR-301	94-V0	IEC/EN 60335-1 IEC/EN 60335-2-25	UL E227341 Tested with appliance
Alt.	Guang Dong High & New Plastic Co Ltd	PP FR-101	94V-0	IEC/EN 60335-1 IEC/EN 60335-2-25	UL E227341 Tested with appliance
Alt.	POLYROCK S CHEMICAL CO.LTD	PP-5000	94-V0	IEC/EN 60335-1 IEC/EN 60335-2-25	UL E340831 Tested with appliance
Plastic supporting frame (fan motor & noise filter board)	Guang Dong High & New Plastic Co Ltd	PP FR-101	94V-0	IEC/EN 60335-1 IEC/EN 60335-2-25	UL E227341 Tested with appliance
Alt.	POLYROCK S CHEMICAL CO.LTD	PP-5000	94-V0	IEC/EN 60335-1 IEC/EN 60335-2-25	UL E340831 Tested with appliance
Plug	Galanz	GAL-01V	AC 250 V, 16 A	DIN VDE 0620-2-1: 2016	KEMA 4323022.01
Alt.	Unirise Electric Wire & Cable Co.,Ltd	UE-312	AC 250 V, 16 A	DIN VDE 0620-2-1: 2016	VDE 40013356
Alt.	Guangdong Rifeng Wire & Cable Co., Ltd	RF-01	AC 250 V, 16 A	DIN VDE 0620-2-1: 2016	VDE 40026780
Alt.	Shenzhen Tongyuan Industrial Co., Ltd	TY-E301A	AC 250 V, 16 A	DIN VDE 0620-2-1: 2016	VDE 40029748
Alt.	Mainland Wire & Cable Co.,Ltd.	ML-302	AC 250 V, 16 A	DIN VDE 0620-2-1: 2016	VDE 40012805

Alt.	Guangdong Xiongrun Electrical Co.,Ltd.	XR-322	AC 250 V, 16 A	DIN VDE 0620-2-1: 2016	VDE 40006857
Alt.	I-Sheng Electric Wire & Cable Co.,Ltd	SP-023	AC 250 V, 16 A	DIN VDE 0620-2-1: 2016	VDE 40013796
Alt.	Dongguan Yuxin Wire & Cable Co.,Ltd.	YX-201	AC 250 V, 16 A	DIN VDE 0620-2-1: 2016	VDE 40001445
Alt.	Friendship Enterprises International Ltd.	FE-03P	AC 250 V, 16 A	DIN VDE 0620-2-1: 2016	VDE 40012926
BS Plug	Galanz	GAL-01B	AC 250V, w/approved 13A current fuse	BS 1363-1: 1995 + A1: 1997 + A2: 2003 + A3: 2009 + A4: 2012	BSI T5012407002
Alt.	Unirise Electric Wire & Cable Co.,Ltd	UE-324	AC 250V, w/approved 13A current fuse	BS 1363-1: 1995 + A1: 1997 + A2: 2003 + A3: 2009 + A4: 2012	ASTA 941
Alt.	Mainland Wire & Cable Co.,Ltd.	ML-313	AC 250V, w/approved 13A current fuse	BS 1363-1: 1995 + A1: 1997 + A2: 2003 + A3: 2009 + A4: 2012	ASTA 876
Alt.	Guangdong Xiongrun Electrical Co.,Ltd.	XR-318A	AC 250V, w/approved 13A current fuse	BS 1363-1: 1995 + A1: 1997 + A2: 2003 + A3: 2009 + A4: 2012	ASTA 737
Alt.	I-SHENG Electric Wire & Cable Co.,Ltd	SP-60	AC 250V, w/approved 13A current fuse	BS 1363-1: 1995 + A1: 1997 + A2: 2003 + A3: 2009 + A4: 2012	ASTA 250
Alt.	Dongguan Yuxin Wire & Cable Co.,Ltd.	YX-901	AC 250V, w/approved 13A current fuse	BS 1363-1: 1995 + A1: 1997 + A2: 2003 + A3: 2009 + A4: 2012	ASTA 1158
Alt.	Shenzhen Tongyuan Industrial Co., Ltd	TY-UK302	AC 250V, w/approved 13A current fuse	BS 1363-1: 1995 + A1: 1997 + A2: 2003 + A3: 2009 + A4: 2012	ASTA 1083
Alt.	Friendship Enterprises International Ltd.	FE-130P	AC 250V, w/approved 13A current fuse	BS 1363-1: 1995 + A1: 1997 + A2: 2003 + A3: 2009 + A4: 2012	KM 99612
Swiss plug	Unirise Electric Wire & Cable Co.,Ltd	UE-345	AC 250 V, 10 A	IEC 60884-1: 2002 + A1: 2006 SEV 1011: 2009 + A1: 2012	ESTI 14.0781
Alt.	Mainland Wire & Cable Co., Ltd.	ML-317	AC 250 V, 10 A	IEC 60884-1: 2002 + A1: 2006 SEV 1011: 2009 + A1: 2012	ESTI 14.0353

Alt.	Guangdong Xiongrun Electrical Co.,Ltd.	XR-313	AC 250 V, 10 A	IEC 60884-1: 2002 + A1: 2006 SEV 1011: 2009 + A1: 2012	ESTI 14.0574
Alt.	I-SHENG Electric Wire & Cable Co.,Ltd	SP-027C	AC 250 V, 10 A	IEC 60884-1: 2002 + A1: 2006 SEV 1011: 2009 + A1: 2012	ESTI 15.0447
Alt.	Dongguan Yuxin Wire & Cable Co.,Ltd.	YX-SEV01	AC 250 V, 10 A	IEC 60884-1: 2002 + A1: 2006 SEV 1011: 2009 + A1: 2012	ESTI 15.0731
Alt.	Friendship Enterprises International Ltd	FE-119P	AC 250 V, 10 A	IEC 60884-1: 2002 + A1: 2006 SEV 1011: 2009 + A1: 2012	ESTI 11.0659
Power cord	Dongguan Yuxin Wire & Cable Co., Ltd.	H05VV-F	3G 1,0mm ² 3G 0,75mm ²	EN 50525-2-11: 2011 IEC 60227-5: 2007	VDE 40012386
Alt.	Unirise Electric Wire & Cable Co.,Ltd	H05VV-F	3G 1,0mm ² 3G 0,75mm ²	EN 50525-2-11: 2011 IEC 60227-5: 2007	VDE 40017449
Alt.	Guangdong Rifeng Wire & Cable Co.,Ltd	H05VV-F	3G 1,0mm ² 3G 0,75mm ²	EN 50525-2-11: 2011 IEC 60227-5: 2007	VDE 40043895
Alt.	I-SHENG Electric Wire & Cable Co.,Ltd	H05VV-F	3G 1,0mm ² 3G 0,75mm ²	EN 50525-2-11: 2011 IEC 60227-5: 2007	VDE 40006070
Alt.	Shenzhen Tongyuan Industrial Co., Ltd	H05VV-F	3G 1,0mm ² 3G 0,75mm ²	EN 50525-2-11: 2011 IEC 60227-5: 2007	VDE 101980
Alt.	Guangdong Mainland Electric Wire & Cable Co., Ltd.	H05VV-F	3G 1,0mm ² 3G 0,75mm ²	EN 50525-2-11: 2011 IEC 60227-5: 2007	VDE 40010355
Alt.	Guangdong Xiongrun Electrical Co., Ltd.	H05VV-F	3G 1,0mm ² 3G 0,75mm ²	EN 50525-2-11: 2011 IEC 60227-5: 2007	VDE 40020627
Alt.	Ningbo Light-Heavy Electronics Technology Co., Ltd	H05VV-F	3G 1,0mm ² 3G 0,75mm ²	EN 50525-2-11: 2011 IEC 60227-5: 2007	VDE 40035166
Alt.	Guangdong Awin Wire & Cable Co., Ltd	H05VV-F	3G 1,0mm ² 3G 0,75mm ²	EN 50525-2-11: 2011 IEC 60227-5: 2007	VDE 40023114
Internal wire to H.V. transforme	Qian Li Ma	Φ0.8	T230, 10KV	IEC/EN 60335-1 IEC/EN 60335-2-25	Tested with appliance

Alt.	HENG WANG ELECTRONI CScO., Ltd	Φ0.8	T230, 10KV	IEC/EN 60335-1 IEC/EN 60335-2-25	Tested with appliance
Internal wire	Linoya Electronic Technology Co Ltd	1015	16-22AWG, 600V, 105°C	IEC/EN 60335-1 IEC/EN 60335-2-25	UL E315619 Tested with appliance
Alt.	Jiangyin Jiangzhou Copper Product Co Ltd	1015	16-22AWG, 600V, 105°C	IEC/EN 60335-1 IEC/EN 60335-2-25	UL E341212 Tested with appliance
Alt.	Kelin Wire Co Ltd (Dongguan)	1569	16-22AWG,300V, 105°C	IEC/EN 60335-1 IEC/EN 60335-2-25	UL E250866 Tested with appliance
Alt.	Fu Tai Electronics Sdn Bhd	1569	16-22AWG,300V, 105°C	IEC/EN 60335-1 IEC/EN 60335-2-25	UL E314597 Tested with appliance
Alt.	Zhongshan Fuyuantong Wire & Cable Co Ltd	1569	16-22AWG,300V, 105°C	IEC/EN 60335-1 IEC/EN 60335-2-25	UL E241989 Tested with appliance
Alt.	Jiangyin Jiangzhou Copper Product Co Ltd	1569	16-22AWG,300V, 105°C	IEC/EN 60335-1 IEC/EN 60335-2-25	UL E341212 Tested with appliance
Alt.	Dongguan Evk Electric Technique Co Ltd	1569	16-22AWG,300V, 105°C	IEC/EN 60335-1 IEC/EN 60335-2-25	UL E302679 Tested with appliance
Alt.	Guangzhou Fengtai Meihua Cable Co Ltd	1332	16-22AWG, 300V, 200°C	IEC/EN 60335-1 IEC/EN 60335-2-25	UL E204798 Tested with appliance
Alt.	Nizing Electric Co Ltd	1332	16-22AWG, 300V, 200°C	IEC/EN 60335-1 IEC/EN 60335-2-25	UL E215834 Tested with appliance
Alt.	Shenzhen Mysun Insulation Materials Co Ltd	1332	16-22AWG, 300V, 200°C	IEC/EN 60335-1 IEC/EN 60335-2-25	UL E239689 Tested with appliance
Alt.	Dongguan Evk Electric Technique Co Ltd	1332	16-22AWG, 300V, 200°C	IEC/EN 60335-1 IEC/EN 60335-2-25	UL E302679 Tested with appliance
Alt.	Shenzhen Mysun Insulation Materials Co Ltd	3122	16-22AWG, 300V, 200°C	IEC/EN 60335-1 IEC/EN 60335-2-25	UL E239689 Tested with appliance
Alt.	Dongguan Evk Electric Technique Co Ltd	3122	16-22AWG, 300V, 200°C	IEC/EN 60335-1 IEC/EN 60335-2-25	UL E302679 Tested with appliance

Alt.	Guangzhou Fengtai Meihua Cable Co Ltd	3122	16-22AWG, 300V, 200°C	IEC/EN 60335-1 IEC/EN 60335-2-25	UL E204798 Tested with appliance
Alt.	Dongguan Boli Electronic Co Ltd	3122	16-22AWG, 300V, 200°C	IEC/EN 60335-1 IEC/EN 60335-2-25	UL E305164 Tested with appliance
Alt.	Nizing Electric Co Ltd	3122	16-22AWG, 300V, 200°C	IEC/EN 60335-1 IEC/EN 60335-2-25	UL E215834 Tested with appliance
PCB/PWB material	Shunde Junda Electronic	JD-B /JD-B1/ JD-D/JD-E	UL94V-0	IEC/EN 60335-1 IEC/EN 60335-2-25	UL E173873 Tested with appliance
Alt.	Guangdong Chengde Electronic Technology Co Ltd	1/2/D1	UL94V-0	IEC/EN 60335-1 IEC/EN 60335-2-25	UL E322995 Tested with appliance
Self-reset Thermal cutout on Oven	Foshan Tianpeng Thermostats CO.,Ltd	T1/11	AC 250 V, 10 A, 1E5, T170, OFF:105°C±5°C ON:85°C±10°C	IEC 60730-1: 2013 IEC 60730-2-9: 2008 + A1: 2011 EN 60730-1: 2016 EN 60730-2-9: 2010	TÜV Rd R50091097
Alt.	Jiangsu Changheng Group Control Component Co., Ltd.	KSD105	AC 250 V, 10 A, T180, 35E3, OFF:105°C±5°C ON:85°C±10°C	IEC 60730-1: 2013 IEC 60730-2-9: 2008 + A1: 2011 EN 60730-1: 2016 EN 60730-2-9: 2010	VDE 40022995
Alt.	XC Electronics (Shenzhen) Corp. Ltd,	KSD301 105	AC 250 V, 10 A, T150, 1E5, OFF:105°C± 5°C ON:85°C± 10°C	IEC 60730-1: 2013 IEC 60730-2-9: 2008 + A1: 2011 EN 60730-1: 2016 EN 60730-2-9: 2010	TÜV Rd R50035898
Alt.	Foshan Lianhe Huilong Electrical Appliance Co. Ltd.	KSD301	AC 250 V, 10 A, T210, 1E5, OFF:105°C± 5°C ON:85°C± 10°C	IEC 60730-1: 2013 IEC 60730-2-9: 2008 + A1: 2011 EN 60730-1: 2016 EN 60730-2-9: 2010	VDE 40034938
Alt.	ChangShu Xin DuAn Electric Co., Ltd.	KSD1	AC 250 V, 10 A, T220, 1E4, OFF:105°C± 5°C ON:85°C± 10°C	IEC 60730-1: 2013 IEC 60730-2-9: 2008 + A1: 2011 EN 60730-1: 2016 EN 60730-2-9: 2010	TÜV Rd R 50374776
Components of Noise Filter, FD0-1K20(Galanz), are listed as below:					
X2 capacitor	Guandong Fengming Electronic Tech.Co.,Ltd.	MKP-X2	AC 275 V, X2, 0,22uF, T105	IEC 60384-14: 2013 EN 60384-14: 2013	VDE 40025702
Alt.	Foshan Shunde Beijiao Hua Da Electric Industrial Co.,Ltd	HD-series	AC 275 V, X2, 0,22uF, T105	IEC 60384-14: 2013 EN 60384-14: 2013	VDE 40027182

Alt.	Shenzhen Shenfeng Electronics Co.,Ltd.	CBB62	AC 275 V, X2, 0,22uF, T100	IEC 60384-14: 2013 EN 60384-14: 2013	VDE 40031777
Y2 capacitor	Haohua Electronic Co.,	CT7	Y2, AC 250 V, 4700pF, T125	IEC 60384-14: 2013 EN 60384-14: 2013	VDE 40013601
Alt.	Nanjing Yuyue Electronics Co.,Ltd.	CT7	Y2, AC 250 V, 4700pF, T125	IEC 60384-14: 2013 EN 60384-14: 2013	VDE 40008013
Relay	Guangdong Galanz Enterprises Co.,Ltd.	JD7-S-124LA	Contact: AC 240 V, 10 A, Coil: DC 24 V, T85, 1E5	IEC 61810-1:2015 EN 61810-1:2015	TUV Rd R50204875
Alt.	Ningbo Tianbo Ganglian Electronics Co.,Ltd.	HJR-21FF-S-H	Contact: AC 240 V, 12 A, Coil: DC 24 V, T85, 1E5	IEC 61810-1:2015 EN 61810-1:2015	TUV Rd R50116165
Alt.	Xiamen Hongfa Electroacoustics Co.,Ltd.	HF152FD 24-1HST	Contact: AC 250 V, 10 A, Coil: DC 24 V, T105, 1E5	IEC 61810-1:2015 EN 61810-1:2015	VDE 40031203
Alt.	Xiamen Hongfa Electroacoustics Co.,Ltd.	HF3FF 024-1H	Contact: AC 250 V, 10 A, Coil: DC 24 V, T85, 1E5	IEC 61810-1:2015 EN 61810-1:2015	TUV Rd R50148356
Alt.	Zhejiang Meishuo Electric Technology Co., LTD	MPA-S-124-A	Contact: AC 250 V, 10 A, Coil: DC 24 V, T85, 1E5	IEC 61810-1:2015 EN 61810-1:2015	TUV Rd R50184948
Current Fuse	Dongguan Better Electronics Technology Co.,Ltd.	524	AC 250 V, 8 A	IEC 60127-1:2006 IEC 60127-2:2014 EN 60127-1: 2006 + A1: 2011 + A2: 2015 EN 60127-2: 2014	VDE 40020107
Alt.	Suzhou Littelfuse OVS Ltd	215	AC 250 V, 8 A	IEC 60127-1:2006 IEC 60127-2:2014 EN 60127-1: 2006 + A1: 2011 + A2: 2015 EN 60127-2: 2014	VDE 40013521
Alt.	Shanghai Songshan Electronics Co.,Ltd.	RF1-20	AC 250 V, 8 A	IEC 60127-1:2006 IEC 60127-2:2014 EN 60127-1: 2006 + A1: 2011 + A2: 2015 EN 60127-2: 2014	TUV Rd J50078894
Alt.	Sun Electric Co.	5C	AC 250 V, 8 A	IEC 60127-1:2006 IEC 60127-2:2014 EN 60127-1: 2006 + A1: 2011 + A2: 2015 EN 60127-2: 2014	TUV Rd R 50202839
Components of Noise Filter, FD9-1K00 or FD9-1K06(Galanz), are listed as below:					

X2 capacitor	Guandong Fengming Electronic Tech.Co.,Ltd.	MKP-X2	AC 275 V, X2, 0,1uF, T105	IEC 60384-14: 2013 EN 60384-14: 2013	VDE 40025702
Alt.	Foshan Shunde Beijiao Hua Da Electric Industrial Co.,Ltd	HD-series	AC 275 V, X2, 0,1uF, T105	IEC 60384-14: 2013 EN 60384-14: 2013	VDE 40027182
Alt.	Shenzhen Shenfeng Electronics Co.,Ltd.	CBB62	AC 275 V, X2, 0,1uF, T100	IEC 60384-14: 2013 EN 60384-14: 2013	VDE 40031777
Y2 capacitor	Haohua Electronic Co.,	CT7	Y2, AC 250 V, 2200pF, T125	IEC 60384-14: 2013 EN 60384-14: 2013	VDE 40013601
Alt.	Nanjing Yuyue Electronics Co.,Ltd.	CT7	Y2, AC 250 V, 2200pF, T125	IEC 60384-14: 2013 EN 60384-14: 2013	VDE 40008013
Relay	Guangdong Galanz Enterprises Co.,Ltd.	JD7-S-124LA	Contact: AC 240 V, 10 A, Coil: DC 24 V, T85, 1E5	IEC 61810-1:2015 EN 61810-1:2015	TUV Rd R50204875
Alt.	Ningbo Tianbo Ganglian Electronics Co.,Ltd.	HJR-21FF-S-H	Contact: AC 240 V, 12 A, Coil: DC 24 V, T85, 1E5	IEC 61810-1:2015 EN 61810-1:2015	TUV Rd R50116165
Alt.	Xiamen Hongfa Electroacoustics Co.,Ltd.	HF152FD 24-1HST	Contact: AC 250 V, 10 A, Coil: DC 24 V, T105, 1E5	IEC 61810-1:2015 EN 61810-1:2015	VDE 40031203
Alt.	Xiamen Hongfa Electroacoustics Co.,Ltd.	HF3FF 024-1H	Contact: AC 250 V, 10 A, Coil: DC 24 V, T85, 1E5	IEC 61810-1:2015 EN 61810-1:2015	TUV Rd R50148356
Alt.	Zhejiang Meishuo Electric Technology Co., LTD	MPA-S-124-A	Contact: AC 250 V, 10 A, Coil: DC 24 V, T85, 1E5	IEC 61810-1:2015 EN 61810-1:2015	TUV Rd R50184948
Current Fuse	Dongguan Better Electronics Technology Co.,Ltd.	524	AC 250 V, 8 A	IEC 60127-1:2006 IEC 60127-2:2014 EN 60127-1: 2006 + A1: 2011 + A2: 2015 EN 60127-2: 2014	VDE 40020107
Alt.	Suzhou Littelfuse OVS Ltd	215	AC 250 V, 8 A	IEC 60127-1:2006 IEC 60127-2:2014 EN 60127-1: 2006 + A1: 2011 + A2: 2015 EN 60127-2: 2014	VDE 40013521

Alt.	Shanghai Songshan Electronics Co.,Ltd.	RF1-20	AC 250 V, 8 A	IEC 60127-1:2006 IEC 60127-2:2014 EN 60127-1: 2006 + A1: 2011 + A2: 2015 EN 60127-2: 2014	TUV Rd J50078894
Alt.	Sun Electric Co.	5C	AC 250 V, 8 A	IEC 60127-1:2006 IEC 60127-2:2014 EN 60127-1: 2006 + A1: 2011 + A2: 2015 EN 60127-2: 2014	TUV Rd R 50202839
Alt.	Shanghai Songshan Electronics Co.,Ltd.	RF1-20	AC 250 V, 8 A	IEC 60127-1:2006 IEC 60127-2:2014 EN 60127-1: 2006 + A1: 2011 + A2: 2015 EN 60127-2: 2014	TUV Rd J 50287670
Components of Noise Filter, FN14-1K00 or FN14-1K06 (Galanz), are listed as below:					
X2 capacitor	Guandong Fengming Electronic Tech.Co.,Ltd.	MKP-X2	AC 275 V, X2, 0,1uF, T105	IEC 60384-14: 2013 EN 60384-14: 2013	VDE 40025702
Alt.	Foshan Shunde Beijiao Hua Da Electric Industrial Co.,Ltd	HD-series	AC 275 V, X2, 0,1uF, T105	IEC 60384-14: 2013 EN 60384-14: 2013	VDE 40027182
Alt.	Shenzhen Shenfeng Electronics Co.,Ltd.	CBB62	AC 275 V, X2, 0,1uF, T100	IEC 60384-14: 2013 EN 60384-14: 2013	VDE 40031777
Y2 capacitor	Haohua Electronic Co.,	CT7	Y2, AC 250 V, 2200pF, T125	IEC 60384-14: 2013 EN 60384-14: 2013	VDE 40013601
Alt.	Nanjing Yuyue Electronics Co.,Ltd.	CT7	Y2, AC 250 V, 2200pF, T125	IEC 60384-14: 2013 EN 60384-14: 2013	VDE 40008013
Current Fuse	Dongguan Better Electronics Technology Co.,Ltd.	524	AC 250 V, 8 A	IEC 60127-1:2006 IEC 60127-2:2014 EN 60127-1: 2006 + A1: 2011 + A2: 2015 EN 60127-2: 2014	VDE 40020107
Alt.	Suzhou Littelfuse OVS Ltd	215	AC 250 V, 8 A	IEC 60127-1:2006 IEC 60127-2:2014 EN 60127-1: 2006 + A1: 2011 + A2: 2015 EN 60127-2: 2014	VDE 40013521
Alt.	Shanghai Songshan Electronics Co.,Ltd.	RF1-20	AC 250 V, 8 A	IEC 60127-1:2006 IEC 60127-2:2014 EN 60127-1: 2006 + A1: 2011 + A2: 2015 EN 60127-2: 2014	TUV Rd J 50078894

Alt.	Sun Electric Co.	5C	AC 250 V, 8 A	IEC 60127-1:2006 IEC 60127-2:2014 EN 60127-1: 2006 + A1: 2011 + A2: 2015 EN 60127-2: 2014	TUV Rd R 50202839
Alt.	Shanghai Songshan Electronics Co.,Ltd.	RF1-20	AC 250 V, 8 A	IEC 60127-1:2006 IEC 60127-2:2014 EN 60127-1: 2006 + A1: 2011 + A2: 2015 EN 60127-2: 2014	TUV Rd J 50287670
Alt.	Shanghai Songshan Electronics Co.,Ltd.	RT1-20	AC 250 V, 8 A	IEC 60127-1:2006 IEC 60127-2:2014 EN 60127-1: 2006 + A1: 2011 + A2: 2015 EN 60127-2: 2014	TUV Rd J 50287669
Components of Control Panel PCB from Galanz, are listed as below for panel PCB model:					
Relay for microwave	Xiamen Hongfa Electroacoustic Co. Ltd.	JQX-62F-012-1H	Contact: AC 250 V, 16 A, Coil: DC12 V, T85, 1E5	IEC 61810-1:2015 EN 61810-1:2015	TUV Rd R50147086
Alt.	Galanz	JD2-1A	Contact: AC 250 V, 16 A, Coil: DC12 V, T85, 1E5	IEC 61810-1:2015 EN 61810-1:2015	TUV Rd R50189204
Alt.	Ningbo Tianbo Ganglian Electronics Co., Ltd	TRA2F-12VDC-H	Contact: AC 250 V, 16 A, Coil: DC12 V, T85, 1E5	IEC 61810-1:2015 EN 61810-1:2015	TUV Rd R50113138
Alt.	Zhejiang Meishuo Electric Technology Co.,LTD	MPL-112-A	Contact: AC 250 V, 16 A, Coil: DC12 V, T105, 1E5	IEC 61810-1:2015 EN 61810-1:2015	TUV Rd R50236892
Relay for mains	Tyco Electronics (Shenzhen) Co., Ltd.	OJ-SS-112LM	Contact: AC 250 V, 3 A, Coil: DC12 V, T85, 1E5	IEC 61810-1:2015 EN 61810-1:2015	TUV Rd R50139166
Alt.	Xiamen Hongfa Electroacoustic Co. Ltd.	JZC-32F-012-HSL3	Contact: AC 250 V, 3 A, Coil: DC12 V, T85, 1E5	IEC 61810-1:2015 EN 61810-1:2015	VDE 40012204
Alt.	Ningbo Tianbo Ganglian Electronics Co., Ltd	TRG1D-12VDC-S-H	Contact: AC 250 V, 5 A, Coil: DC12 V, T85, 1E5	IEC 61810-1:2015 EN 61810-1:2015	TUV Rd R50108695
Alt.	Zhejiang Meishuo Electric Technology Co.,LTD	MPD-S-112-A	Contact: AC 250 V, 5 A, Coil: DC12 V, T105, 1E5	IEC 61810-1:2015 EN 61810-1:2015	TUV Rd R50184948

Switching power supply	GALANZ	MPP001	AC 90-240V, 50/60Hz 5W, DC5V 200mA, DC12V 200mA, 75°C	IEC 61558-1:2005+A1:2009 ; IEC 61558-2-16:2009+A1:2013 EN 61558-2-16 :2009+A1 :2013	TÜV Rd R50170616
Switch mode power supply PCB incorporated in control panel PCB:					
High frequency transformer	GALANZ	GAL-TR006	Pri. winding: N1: Φ 0,17mm×37Ts N2: Φ0,17mm×111Ts N3: Φ 0,17mm×0,9Ts Sec. winding: N4: Φ 0,35mm×6Ts N5: Φ 0,40mm×8Ts Class 130	IEC 61558-1:2005+A1:2009 ; IEC 61558-2-16:2009+A1:2013 EN 61558-2-16 :2009+A1 :2013	Tested with appliance
Varistor	Joyin Company Ltd	10N471K	Varistor Voltage:470V T85	IEC 61051-1: 2007 IEC 61051-2: 1991 IEC 61051-2-2: 1991 DIN EN 61051-1:2009	VDE 005937
Alt.	Fenghua Advanced Tech. (Holding) Co., Ltd.	FNR-10K471 FNR-14K471	Varistor Voltage:470V T85	IEC 61051-1: 2007 IEC 61051-2: 1991 IEC 61051-2-2: 1991 DIN EN 61051-1:2009	VDE 40008242
Alt.	Guangdong Fashan Kestar Electronic Co., Ltd.	MYG10-471A	Varistor Voltage:470V T85	IEC 61051-1: 2007 IEC 61051-2: 1991 IEC 61051-2-2: 1991 DIN EN 61051-1:2009	VDE 40005616
Alt.	Hongzhi Enterprise Ltd.	HEL-10D471K	Varistor Voltage:470V T85	IEC 61051-1: 2007 IEC 61051-2: 1991 IEC 61051-2-2: 1991 DIN EN 61051-1:2009	VDE 40037512
Alt.	Centra Science Corp.	CNR-10D471K CNR-14D471K	Varistor Voltage:470V T85	IEC 61051-1: 2007 IEC 61051-2: 1991 IEC 61051-2-2: 1991 DIN EN 61051-1:2009	VDE 40008220

Alt.	Haohua Electronic Co.,	HVR 10K471, HVR 14K471	Varistor Voltage:470V, T85	IEC 61051-1: 2007 IEC 61051-2: 1991 IEC 61051-2-2: 1991 DIN EN 61051- 1:2009	VDE 40031718
Optocoupler	SHARP CORP ELECTRONI C	PC817	Viso=5000V, T100	IEC 60747-5-5	VDE40008087
Alt.	Lite-On Technology Corporation	LTV-817	Viso=5000V, T110	IEC 60747-5-5	VDE 40015248
Alt.	Toshiba Corporation	TLP785	Viso=5000V, T115	IEC 60747-5-5	VDE 40031808

28.1	TABLE: Threaded part torque test			P
Threaded part identification	Diameter of thread (mm)	Column number (I, II, or III)	Applied torque (Nm)	
Screw for earthing terminal	3,8	II	1,2	
Supplementary information: --				

29.1	TABLE: Clearances					P
Overvoltage category		II			—	
		Type of insulation:				
Rated impulse voltage (V):	Min. cl (mm)	Basic (mm)	Supplementary (mm)	Reinforced (mm)	Functional (mm)	Verdict / Remark
330	0,2* / 0,5 / 0,8**	—	—	—	—	N/A
500	0,2* / 0,5 / 0,8**	—	—	—	—	N/A
800	0,2* / 0,5 / 0,8**	—	—	—	—	N/A
1 500	0,5 / 0,8** / 1,0***	—	—	—	—	N/A
2 500	1,5 / 2,0***	c) 4,2 e) 3,5 f) 7,5			a) 4,0 d) 4,1	P
4 000	3,0 / 3,5***	—	—	b) 3,9	—	P
6 000	5,5 / 6,0***	g) 23,5 h) 24,3	—	—	—	P
8 000	8,0 / 8,5***	—	—	—	—	N/A
10 000	11,0 / 11,5***	—	—	—	—	N/A

Supplementary information:

*) For tracks on printed circuit boards if pollution degree 1 and 2

**) For pollution degree 3

***) If the construction is affected by wear, distortion, movement of the parts or during assembly

- a) B/W L and N on control panel PCB;
- b) B/W Live part of H,F, transformer and SELV on control panel PCB;
- c) B/W Live part and earthed part on noise filter PCB;
- d) B/W L and N on noise filter PCB;
- e) B/W Fan motor winding and iron core;
- f) B/W Turntable motor winding and iron core;
- g) B/W Magnetron terminal and earthed metal;
- h) B/W Secondary winding of H,V, transformer and earthed iron core.

29.2	TABLE: Creepage distances, basic, supplementary and reinforced insulation										P
Working voltage (V)	Creepage distance (mm)							Type of insulation			Verdict
	Pollution degree										
	1	2			3						
		Material group			Material group						
		I	II	IIIa/IIIb	I	II	IIIa/IIIb*)	B**)	S**)	R**)	
≤50	0,18	0,6	0,85	1,2	1,5	1,7	1,9		—	—	N/A
≤50	0,18	0,6	0,85	1,2	1,5	1,7	1,9	—		—	N/A
≤50	0,36	1,2	1,7	2,4	3,0	3,4	3,8	—	—		N/A
125	0,28	0,75	1,05	1,5	1,9	2,1	2,4		—	—	N/A
125	0,28	0,75	1,05	1,5	1,9	2,1	2,4	—		—	N/A
125	0,56	1,5	2,1	3,0	3,8	4,2	4,8	—	—		N/A
250	0,56	1,25	1,8	2,5	3,2	3,6	4,0	c) 4,2 e) 6,8 f) 9,5	—	—	P
250	0,56	1,25	1,8	2,5	3,2	3,6	4,0	—		—	N/A
250	1,12	2,5	3,6	5,0	6,4	7,2	8,0	—	—	b) 8,6	P
400	1,0	2,0	2,8	4,0	5,0	5,6	6,3		—	—	N/A
400	1,0	2,0	2,8	4,0	5,0	5,6	6,3	—		—	N/A
400	2,0	4,0	5,6	8,0	10,0	11,2	12,6	—	—		N/A
500	1,3	2,5	3,6	5,0	6,3	7,1	8,0		—	—	N/A
500	1,3	2,5	3,6	5,0	6,3	7,1	8,0	—		—	N/A
500	2,6	5,0	7,2	10,0	12,6	14,2	16,0	—	—		N/A
>630 and ≤800	1,8	3,2	4,5	6,3	8,0	9,0	10,0		—	—	N/A

>630 and ≤800	1,8	3,2	4,5	6,3	8,0	9,0	10,0	—	—	—	N/A
>630 and ≤800	3,6	6,4	9,0	12,6	16,0	18,0	20,0	—	—	—	N/A
>800 and ≤1000	2,4	4,0	5,6	8,0	10,0	11,0	12,5	—	—	—	N/A
>800 and ≤1000	2,4	4,0	5,6	8,0	10,0	11,0	12,5	—	—	—	N/A
>800 and ≤1000	4,8	8,0	11,2	16,0	20,0	22,0	25,0	—	—	—	N/A
>1000 and ≤1250	3,2	5,0	7,1	10,0	12,5	14,0	16,0	—	—	—	N/A
>1000 and ≤1250	3,2	5,0	7,1	10,0	12,5	14,0	16,0	—	—	—	N/A
>1000 and ≤1250	6,4	10,0	14,2	20,0	25,0	28,0	32,0	—	—	—	N/A
>1250 and ≤1600	4,2	6,3	9,0	12,5	16,0	18,0	20,0	—	—	—	N/A
>1250 and ≤1600	4,2	6,3	9,0	12,5	16,0	18,0	20,0	—	—	—	N/A
>1250 and ≤1600	8,4	12,6	18,0	25,0	32,0	36,0	40,0	—	—	—	N/A
>1600 and ≤2000	5,6	8,0	11,0	16,0	20,0	22,0	25,0	—	—	—	N/A
>1600 and ≤2000	5,6	8,0	11,0	16,0	20,0	22,0	25,0	—	—	—	N/A
>1600 and ≤2000	11,2	16,0	22,0	32,0	40,0	44,0	50,0	—	—	—	N/A
>2000 and ≤2500	7,5	10,0	14,0	20,0	25,0	28,0	32,0	h) 26,3	—	—	P
>2000 and ≤2500	7,5	10,0	14,0	20,0	25,0	28,0	32,0	—	—	—	N/A
>2000 and ≤2500	15,0	20,0	28,0	40,0	50,0	56,0	64,0	—	—	—	N/A
>2500 and ≤3200	10,0	12,5	18,0	25,0	32,0	36,0	40,0	g) 28,1	—	—	P
>2500 and ≤3200	10,0	12,5	18,0	25,0	32,0	36,0	40,0	—	—	—	N/A
>2500 and ≤3200	20,0	25,0	36,0	50,0	64,0	72,0	80,0	—	—	—	N/A
>3200 and ≤4000	12,5	16,0	22,0	32,0	40,0	45,0	50,0	—	—	—	N/A
>3200 and ≤4000	12,5	16,0	22,0	32,0	40,0	45,0	50,0	—	—	—	N/A
>3200 and ≤4000	25,0	32,0	44,0	64,0	80,0	90,0	100,0	—	—	—	N/A
>4000 and ≤5000	16,0	20,0	28,0	40,0	50,0	56,0	63,0	—	—	—	N/A
>4000 and ≤5000	16,0	20,0	28,0	40,0	50,0	56,0	63,0	—	—	—	N/A
>4000 and ≤5000	32,0	40,0	56,0	80,0	100,0	112,0	126,0	—	—	—	N/A
>5000 and ≤6300	20,0	25,0	36,0	50,0	63,0	71,0	80,0	—	—	—	N/A
>5000 and ≤6300	20,0	25,0	36,0	50,0	63,0	71,0	80,0	—	—	—	N/A
>5000 and ≤6300	40,0	50,0	72,0	100,0	126,0	142,0	160,0	—	—	—	N/A
>6300 and ≤8000	25,0	32,0	45,0	63,0	80,0	90,0	100,0	—	—	—	N/A
>6300 and ≤8000	25,0	32,0	45,0	63,0	80,0	90,0	100,0	—	—	—	N/A
>6300 and ≤8000	50,0	64,0	90,0	126,0	160,0	180,0	200,0	—	—	—	N/A
>8000 and ≤10000	32,0	40,0	56,0	80,0	100,0	110,0	125,0	—	—	—	N/A
>8000 and ≤10000	32,0	40,0	56,0	80,0	100,0	110,0	125,0	—	—	—	N/A

>8000 and ≤10000	64,0	80,0	112,0	160,0	200,0	220,0	250,0	—	—		N/A
>10000 and ≤12500	40,0	50,0	71,0	100,0	125,0	140,0	160,0		—	—	N/A
>10000 and ≤12500	40,0	50,0	71,0	100,0	125,0	140,0	160,0	—		—	N/A
>10000 and ≤12500	80,0	100,0	142,0	200,0	250,0	280,0	320,0	—	—		N/A

Supplementary information:
 *) Material group IIIb is allowed if the working voltage does not exceed 50 V
 **) B = Basic insulation, S = Supplementary insulation, R = Reinforced insulation

29.2	TABLE: Creepage distances, functional insulation								P
Working voltage (V)	Creepage distance (mm) Pollution degree							Verdict / Remark	
	1	2			3				
	Material group				Material group				
	I	II	IIIa/IIIb	I	II	IIIa/IIIb ^{*)}			
≤10	0,08	0,4	0,4	0,4	1,0	1,0	1,0	N/A	
50	0,16	0,56	0,8	1,0	1,4	1,6	1,8	N/A	
125	0,25	0,71	1,0	1,4	1,8	2,0	2,2	N/A	
250	0,42	1,0	1,4	2,0	2,5	2,8	3,2	a) 4,0 / P d) 4,1 / P	
400	0,75	1,6	2,2	3,2	4,0	4,5	5,0	N/A	
500	1,0	2,0	2,8	4,0	5,0	5,6	6,3	N/A	
>630 and ≤800	1,8	3,2	4,5	6,3	8,0	9,0	10,0	N/A	
>800 and ≤1000	2,4	4,0	5,6	8,0	10,0	11,0	12,5	N/A	
>1000 and ≤1250	3,2	5,0	7,1	10,0	12,5	14,0	16,0	N/A	
>1250 and ≤1600	4,2	6,3	9,0	12,5	16,0	18,0	20,0	N/A	
>1600 and ≤2000	5,6	8,0	11,0	16,0	20,0	22,0	25,0	N/A	
>2000 and ≤2500	7,5	10,0	14,0	20,0	25,0	28,0	32,0	N/A	
>2500 and ≤3200	10,0	12,5	18,0	25,0	32,0	36,0	40,0	N/A	
>3200 and ≤4000	12,5	16,0	22,0	32,0	40,0	45,0	50,0	N/A	
>4000 and ≤5000	16,0	20,0	28,0	40,0	50,0	56,0	63,0	N/A	
>5000 and ≤6300	20,0	25,0	36,0	50,0	63,0	71,0	80,0	N/A	
>6300 and ≤8000	25,0	32,0	45,0	63,0	80,0	90,0	100,0	N/A	
>8000 and ≤10000	32,0	40,0	56,0	80,0	100,0	110,0	125,0	N/A	
>10000 and ≤12500	40,0	50,0	71,0	100,0	125,0	140,0	160,0	N/A	

Supplementary information:
 *) Material group IIIb is allowed if the working voltage does not exceed 50 V

IEC 60335-2-25

30	TABLE: Resistance to heat and fire																	P	
Object/ part No.	Manufacturer / trademark	Type/ model	Ball pressure test °C				Glow wire test (GWT) °C				Glow-wire flammability index (GWFI) °C				Glow- wire ignition temp. (GWIT) °C		Needle - flame test (NFT)	Verdict	
			75	125	cl. 11 +40	cl. 19 +25	550	650		750		850	550	650	750	850			675
								te		ti									
Fan motor	Galanz	GAL63 09E(3 0)-ZD		1,3 mm				0s	0s										P
Turntable motor	Galanz	SM- 16T		1,0 mm				0s	0s										P
Timer (30 mins)	Galanz	TM30 MU01 E(30)		1,4 mm						0s	0s	X							P
High voltage capacitor	Ningbo Bicai Industry Co., Ltd.	CH85 21090								0s	0s	X							P
High voltage capacitor	Anhui Juan kuang Electric Co.,Ltd	CH85								0s	0s	X							P
Lamp holder	Yuyao Changhong Electric Factory	E14-A		160 °C 1,0 mm						0s	0s	X							P

IEC 60335-2-25

				7)																
Lamp and holder (Integrated lamp)	Deqing New Minghui Electric Lighting Co.,Ltd.	Z187		160 °C 1,0 mm 7)						0s	0s	X								P
Lamp and holder (Integrated lamp)	Yuyao Jiahong Electric	Z187		160 °C 1,0 mm 7)						0s	0s	X								P
Lamp and holder (Integrated lamp)	Deqing Dinghui Lighting Co.,Ltd.	F-E14		160 °C 1,0 mm 7)						0s	0s	X								P
Lamp and holder (Integrated lamp)	Deqing Xinjiyuan Appliance Lighting Co., Ltd.	F-E14		160 °C 1,0 mm 7)						0s	0s	X								P
Magnetron	Galanz	M24F A-210A		1,2 mm						4s	1s	X							P	P
Micro switch	Guangdong Galanz Enterprises Co., Ltd.	W-15-102C W-15-302C								0s	0s	X								P
Micro switch	Yueqing Tongda Wire Electric Factory	HK-14								0s	0s	X								P

IEC 60335-2-25

Plastic Control Panel	CHI MEI corporation	ABS PA-777D			100° C 1,6 mm ⁷⁾		X													P
Plastic Control Panel	LG CHEM LTD	ABS HI121 H			100° C 1,6 mm ⁷⁾		X													P
Plastic Control Panel	LG CHEM LTD	ABS AF312 C			100° C 1,6 mm ⁷⁾		X													P
Plastic Control Panel	LG CHEM LTD	ABS AF327 (&)			100° C 1,6 mm ⁷⁾		X													P
Plastic Control Panel	SILVER AGE ENGINEERING PLASTICS (DONGGUAN) CO LTD	ABS 3360			100° C 1,6 mm ⁷⁾		X													P
Plastic door cover	CHI MEI corporation	ABS PA-777D			100° C 1,6 mm ⁷⁾		X													P
Plastic door cover	LG CHEM LTD	ABS HI121 H			100° C 1,6 mm ⁷⁾		X													P
Plastic material	Guangzhou Keyuan	PBT30 1-G20			125°C 1,6		X													P

IEC 60335-2-25

supporting micro switch	Innovative Materials Co Ltd			mm ⁷⁾															
Plastic material supporting micro switch	Guangdong Rynon New Material Co.,Ltd	PBT-V3020		125°C 1,6 mm ⁷⁾		X													P
Plastic material supporting micro switch	Guang Dong High & New Plastic Co Ltd	PBT FR-301		125°C 1,6 mm ⁷⁾		X													P
Plastic material supporting micro switch	Guang Dong High & New Plastic Co Ltd	PP FR-101		125°C 1,6 mm ⁷⁾		X													P
Plastic material supporting micro switch	POLYROCK S CHEMICAL CO.LTD	PP-5000		125°C 1,6 mm ⁷⁾		X													P
Plastic supporting frame (fan motor & noise filter board)	Guang Dong High & New Plastic Co Ltd	PP FR-101		125°C 1,6 mm ⁷⁾		X													P
Plastic supporting frame (fan motor & noise filter board)	POLYROCK S CHEMICAL CO.LTD	PP-5000		125°C 1,6 mm ⁷⁾		X													P
PCB/PWB material	Shunde Junda	JD-B /JD-																P	P

IEC 60335-2-25

	Electronic	B1/ JD- D/JD- E																	
PCB/PWB material	Guangdong Chengde Electronic Technology Co Ltd	1/2/D1																P	P
Self-reset Thermal cutout on Oven	Foshan Tianpeng Thermostats CO.,Ltd	T1/11							0s	0s	X								P
Self-reset Thermal cutout on Oven	Jiangsu Changheng Group Control Component Co., Ltd.	KSD10 5							0s	0s	X								P
Self-reset Thermal cutout on Oven	XC Electronics (Shenzhen) Corp. Ltd,	KSD30 1 105							0s	0s	X								P
Self-reset Thermal cutout on Oven	Foshan Lianhe Huilong Electrical Appliance Co. Ltd.	KSD30 1							0s	0s	X								P
Self-reset Thermal cutout on Oven	ChangShu Xin DuAn Electric Co., Ltd.	KSD1							0s	0s	X								P

IEC 60335-2-25

X2 capacitor	Guandong Fengming Electronic Tech.Co.,Ltd.	MKP-X2						0s	0s										P
X2 capacitor	Foshan Shunde Beijiao Hua Da Electric Industrial Co.,Ltd	HD-series						0s	0s										P
X2 capacitor	Shenzhen Shenfeng Electronics Co.,Ltd.	CBB62						0s	0s										P
Relay	Guangdong Galanz Enterprises Co.,Ltd.	JD7-S-124LA								0s	0s	X							P
Relay	Ningbo Tianbo Ganglian Electronics Co.,Ltd.	HJR-21FF-S-H								0s	0s	X							P
Relay	Xiamen Hongfa Electroacoustics Co.,Ltd.	HF152 FD 24-1HST								0s	0s	X							P
Relay	Xiamen Hongfa Electroacoustics Co.,Ltd.	HF3FF 024-1H								0s	0s	X							P
Relay	Zhejiang Meishuo	MPA-S-124-								0s	0s	X							P

IEC 60335-2-25

	Electric Technology Co., LTD	A																		
Relay	Xiamen Hongfa Electroacoustic Co. Ltd.	JQX-62F-012-1H							0s	0s	X									P
Relay	Galanz	JD2-1A							0s	0s	X									P
Relay	Ningbo Tianbo Ganglian Electronics Co., Ltd	TRA2F - 12VD C-H							0s	0s	X									P
Relay	Zhejiang Meishuo Electric Technology Co.,LTD	MPL-112-A							0s	0s	X									P
Relay	Tyco Electronics (Shenzhen) Co., Ltd.	OJ-SS-112LM							0s	0s	X									P
Relay	Xiamen Hongfa Electroacoustic Co. Ltd.	JZC-32F-012-HSL3							0s	0s	X									P
Relay	Ningbo Tianbo Ganglian Electronics Co., Ltd	TRG1 D-12VD C-S-H							0s	0s	X									P

IEC 60335-2-25

Relay	Zhejiang Meishuo Electric Technology Co.,LTD	MPD-S-112-A								0s	0s	X								P	
H,V, fuse holder	--	--		125 °C						0s	0s	X									P
High frequency transformer	GALANZ	GAL-TR006		0,8 mm						0s	0s	X									P
All terminal tubes	--	--								0s	0s	X							P		P
Connector on PCB	--	--								0s	0s	X									P

Supplementary information:

- 1) Parts of material classified at least HB40 or if relevant HBFs
- 2) Parts of material classified as V-0 or V-1
- 3) Flame persisting longer than 2 s (= $t_e - t_i$) need only be reported for unattended appliances
- 4) Surrounding parts subjected to the needle-flame test of annex E
- 5) Base material classified as V-0 or if relevant VTM-0
- 6) The GWIT pre-selection option, the 850 °C GWF1 pre-selection option, and the 850 °C GWT are not applicable for attended appliances
- 7) Tested at higher temperature than required.

-- End of report --

IEC 60335-1:2010/A2:2016			
Clause	Requirement - Test	Result - Remark	Verdict

ATTACHMENT TO TEST REPORT IEC 60335-1 Household and similar electrical appliances – Safety – Part 1: General requirements	
Differences according to:	IEC 60335-1:2010 /A2: 2016
Attachment Form No.:	IEC60335-1/A2_A
Attachment Originator:	SGS-CSTC
Master Attachment:	Date 2016-06

IEC 60335-1:2010/A2:2016			
Clause	Requirement - Test	Result - Remark	Verdict
7	Marking and instructions		—
7.1	<p><i>Replace the last dashed item in the first paragraph by the following:</i></p> <p>– symbol IEC 60417-5180 (2003-02), for class III appliances. This marking is not necessary for appliances operated only by batteries (primary batteries or secondary batteries recharged outside of the appliance) or appliances powered by rechargeable batteries recharged in the appliance.</p> <p><i>Add the following new sub clause:</i></p>		N/A
7.12.9	<p>For each language, the instructions specified in 7.12 and from 7.12.1 to 7.12.8 shall appear together before any other instructions supplied with the appliance. Alternatively, these instructions may be supplied with the appliance separately from any functional use booklet.</p>		P
	<p>They may follow the description of the appliance that identifies parts, or follow the drawings/sketches common to the languages of the instructions. In addition, instructions shall also be available in an alternative format such as on a website or on request from the user in a format such as a DVD.</p> <p><i>Compliance is checked by inspection.</i></p>		P
7.14	<p><i>Add the following as new second paragraph to the requirement:</i></p> <p>The signal words WARNING, CAUTION, DANGER if in the Latin alphabet shall be in uppercase having a height not less than</p> <ul style="list-style-type: none"> – 3,5 mm for appliances normally used on the floor; – 2,0 mm for portable appliances with a printable surface of less than 10 cm²; and – 3,0 mm for other appliances. <p>NOTE A height of 3,5 mm is similar to Arial 14 pt, 3,0 mm is similar to 12 pt Arial and 2,0 mm is similar to 8 pt Arial. Other typefaces might differ in the pt value.</p>		N/A
	<p>Uppercase letter of the text explaining the signal word shall be no smaller than 1,6 mm, with other letters according to the font size of the uppercase letter.</p>		N/A
	<p>Countries that do not use the Latin alphabet need to specify the minimum size of the script to be used taking into account what is specified for the Latin alphabet.</p>		N/A
	<p>Unless contrasting colours are used, moulded in, engraved, or stamped markings shall be either raised above or have a depth below the surface of at least 0,25 mm.</p>		N/A

IEC 60335-1:2010/A2:2016			
Clause	Requirement - Test	Result - Remark	Verdict
	Replace the first paragraph of the test specification by the following: Compliance is checked by inspection, by measurement and by rubbing the marking by hand for 15 s with a piece of cloth soaked with water and again for 15 s with a piece of cloth soaked with petroleum spirit. The petroleum spirit to be used for the test is aliphatic solvent hexane.		P
8.1.3	Replace the note by the following. If a single switching action is obtained by a switching device, the switching device shall provide full disconnection and the clearances for full disconnection specified in 20.1.5.3 of IEC 61058-1:2000 shall be obtained from Table 22 of IEC 61058-1:2000 using the next higher step for rated impulse withstand voltage.		N/A
	For appliances provided with a supply cord and without a switching device in their supply circuit, a single switching action may be obtained by the withdrawal of the plug from a socket outlet. Compliance is checked by inspection and by manual test.		N/A
13.2	Replace the first paragraph by the following: The leakage current is measured by means of the circuit described in Figure 4 of IEC 60990:1999. For class 0I appliances and class I appliances , except parts of class II construction , C may be replaced by a low impedance ammeter responding to the rated frequency of the appliance.		P
19.1	Add the following to the penultimate paragraph of the test specification: If the control performs more than one function, only that aspect of the control under consideration is rendered inoperative. Other functions of the control may continue to operate normally.		N/A
19.7	In the third paragraph of the test specification, replace "class P2" by "class S2 or S3".		N/A
19.11.3	Replace the text of the test specification but not the note, by the following. If the appliance incorporates a protective electronic circuit that operates to ensure compliance with Clause 19, the appliance is tested as follows: A fault as indicated in a) to g) of 19.11.2 shall be incorporated in the protective electronic circuit either before the appliance is started or at any point in time after the appliance is started so that the most unfavourable conditions of the test are applied.		N/A
	If the appliance is able to operate after the fault in the protective electronic circuit is incorporated, then the appliance is further tested as follows.		N/A

IEC 60335-1:2010/A2:2016			
Clause	Requirement - Test	Result - Remark	Verdict
	<i>For appliances for continuous operation the appliance is operated until steady conditions are reached. Then the relevant test of Clause 19 is repeated.</i>		N/A
	<i>Other appliances are operated for one cycle of operation. Then the relevant test of Clause 19 is repeated.</i>		N/A
19.11.4.2	<i>Replace the test specification but not the note, by the following: The appliance is subjected to radiated fields in accordance with IEC 61000-4-3. The frequency ranges tested shall be: – 80 MHz to 1 000 MHz, test level 3; – 1,4 GHz to 2,0 GHz, test level 3; – 2,0 GHz to 2,7 GHz, test level 2.</i>		N/A
22.5	<i>Replace the requirement by the following: Appliances intended to be connected to the supply mains by means of a plug or pins for insertion into socket-outlets shall be constructed so that in normal use, when pins are touched, there is no risk of electric shock from charged capacitors having a rated capacitance equal to or greater than 0,1 µF.</i>		P
22.12	<i>Replace the requirement by the following: Handles, knobs, grips, levers and parts providing a similar function shall be fixed in a reliable manner so that they will not work loose in normal use if loosening could result in a hazard, including a choking hazard. If these parts are used to indicate the position of switches or similar components, it shall not be possible to remove or fix them incorrectly if this could result in a hazard. The requirement concerning the choking hazard does not apply to appliances intended for commercial use. Add the following new paragraph to the test specification:</i>		P
	<i>If the part is removed and can be contained within the small parts cylinder in Figure 13, its loosening is considered to result in a choking hazard. Add the following new subclauses:</i>		P
22.55	<i>Devices that are operated by the user to stop the intended function of the appliance, if any, shall be distinguished from other manual devices by means of shape, or size, or surface texture, or position. This requirement concerning position does not preclude use of a push on push off switch. An indication when the device has been operated shall be given by: – tactile feedback from the actuator or tactile feedback from the appliance such as stopping of the vibration on the body of the appliance or of a part of it; or – reduction in heat output; or – audible and visible feedback.</i>		P

IEC 60335-1:2010/A2:2016			
Clause	Requirement - Test	Result - Remark	Verdict
	The sound of the motor or sound of an actuator switching from on to off is considered as an audible feedback. A switch with a stable off-position different from the on-position is considered visual and tactile feedback. The force feedback from the actuator when operating it is considered to be tactile feedback. <i>Compliance is checked by inspection and by manual test.</i>		P
22.56	Detachable power supply part shall be provided with the part of class III construction of the appliance. <i>Compliance is checked by inspection.</i>		N/A
22.57	The properties of non-metallic materials shall not degrade from exposure to UV-C radiation generated from UV sources provided for microbiological control within the appliance such that they no longer comply with this standard. This requirement does not apply to glass, ceramics or similar materials. <i>Compliance is checked by the conditioning and tests of Annex T.</i>		N/A
24.2	<i>Replace the first dashed item of 24.2 by the following.</i> – switches, automatic controls, power supplies and the like in flexible cords;		P
24.8	<i>In the first dashed item of the second paragraph of the requirement replace “class of safety protection P2” by “class of safety protection S2 or S3”.</i>		N/A
25.7	<i>Add to the end of the dashed items:</i> – Halogen-free, low smoke, thermoplastic insulated and sheathed Their properties should at least be those of: • Light duty halogen-free low smoke flexible cable (code designation 62821 IEC 101 for circular cable and code designation 62821 IEC 101f for flat cable); • Ordinary duty halogen-free, low smoke flexible cable (code designation 62821 IEC 102 for circular cable and code designation 62821 IEC 102f for flat cable).		N/A
25.10	<i>Add the following to the requirement as a new third paragraph:</i> Where additional neutral conductors are provided in the supply cord – other colours may be used for these additional neutral conductors; – all of the neutral conductors and line conductors shall be identified by marking using the alpha numeric notation specified in IEC 60445; – the supply cord shall be fitted to the appliance.		N/A

IEC 60335-1:2010/A2:2016			
Clause	Requirement - Test	Result - Remark	Verdict
25.23	<i>Add the following new dashed item to the requirement:</i> – for class III construction , interconnection cords of a class I appliance or class II appliance , the cross sectional areas of the conductors need not comply with 25.8 if the temperature of the cord insulation specified in Table 3 and Table 9 are not exceeded during the tests of Clause 11 and Clause 19, respectively.		N/A
Annex B	Appliances powered by rechargeable batteries that are recharged in the appliance		N/A
7.12	<i>Replace the third paragraph and three dashed items by the following:</i> Instructions for appliances containing non user-replaceable batteries shall state the substance of the following: This appliance contains batteries that are only replaceable by skilled persons.		N/A
	Instructions for appliances containing non-replaceable batteries shall state the substance of the following: This appliance contains batteries that are non-replaceable.		N/A
Annex P	– Guidance for the application of this standard to appliances used in warm damp equable climates		N/A
Annex T	UV-C radiation effect on non-metallic materials		N/A

---End of Attachment 1---

IEC60335_2_25J - ATTACHMENT			
Clause	Requirement - Test	Result - Remark	Verdict

<p align="center">ATTACHMENT TO TEST REPORT IEC 60335-2-25 EUROPEAN GROUP DIFFERENCES AND NATIONAL DIFFERENCES Household and similar electrical appliances – Safety – Part 2: Particular requirements for microwave ovens</p>	
Differences according to:	EN 60335-2-25: 2012 + A1: 2015 + A2: 2016 used in conjunction with EN 60335-1:2012 + A11:2014 EN 62233:2008
Attachment Form No.:	EU_GD_IEC60335_2_25J
Attachment Originator:	SGS-CSTC
Master Attachment:	2018-04
Copyright © 2015 IEC System for Conformity Testing and Certification of Electrical Equipment (IECEE), Geneva, Switzerland. All rights reserved.	

Attachment 2

Clause	Requirement - Test	Result - Remark	Verdict
	CENELEC COMMON MODIFICATIONS		
6.1	Delete "class 0" and "class 01"		P
7.1	Single-phase appliances to be connected to the supply mains: 230 V covered		P
	Multi-phase appliances to be connected to the supply mains: 400 V covered		N/A
7.10	Devices used to start/stop operational functions of the appliance distinguished from other manual devices by means of shape, size, surface texture, position, etc.		P
	An indication that the device has been operated is given by:		--
	• a tactile feedback, or		P
	• an audible and visual feedback		P
7.12	The instructions include the substance of the following:		--
	- this appliance can be used by children aged from 8 years and above and persons with reduced physical, sensory or mental capabilities or lack of experience and knowledge if they have been given supervision or instruction concerning use of the appliance in a safe way and understand the hazards involved		P
	- children shall not play with the appliance		P
	- cleaning and user maintenance shall not be made by children without supervision		P
7.12.Z1	The specific instructions related to the safe operation of this appliance is collated together in the front section of the user instructions		P
	The height of the characters, measured on the capital letters, is at least 3 mm		P
	These instructions are also available in an alternative format, e.g. on a website		P
8.1.1	Also test probe 18 of EN 61032 is applied		P
	The appliance being in every possible position during the test		P
	The force on the probe in the straight position is increased to 10 N when probe 18 is used		P
	When using test probe 18 the appliance is fully assembled as in normal use without any parts removed, and		P

Attachment 2

Clause	Requirement - Test	Result - Remark	Verdict
	parts intended to be removed for user maintenance are also not removed		P
8.2	Compliance is checked by applying the test probes of EN 61032		P
	For built-in appliances and fixed appliances, the test probe B and probe 18 of EN 61032 are applied only after installation		N/A
11.8	Footnotes to "External enclosure of motor-operated appliances" to be taken into account		P
	During the test, the temperature rises are monitored continuously and shall not exceed the values shown in Table 3. Replace in Table 3 the row "External enclosure of motor-operated appliances, except handles held in normal use" and the corresponding footnotes by Table Z101. (EN 60335-2-25)	(See appended table)	P
15.1.2	Appliances with an automatic cord reel tested with the cord in the most unfavourable position so that the reeling of the wet cord may affect electrical insulation during operation, the cord not being dried before reeling		N/A
20.2	When using the test probe similar to test probe B with a circular stop face, the accessories and detachable covers are removed		P
	Test probe 18 applied with a force of 2,5N on the appliance fully assembled		P
22.105	At least one door interlock concealed and not operable by manipulation: use of test probe B and test probe 18 of IEC 61032 in turn to all openings. (EN 60335-2-25)		P
	The door interlock operates before any accessible door interlock can be defeated		P
24.1	Components comply with the safety requirements specified in the relevant standards as far as they reasonably apply		P
	The requirements of Clause 29 of this standard apply between live parts of components and accessible parts of the appliance.		P
	The requirements of 30.2 of this standard apply to parts of non-metallic material in components including parts of non-metallic material supporting current-carrying connections inside components		P

Attachment 2

Clause	Requirement - Test	Result - Remark	Verdict
	Components that have not been previously tested or do not comply with the standard for the relevant component are tested according to the requirements of 30.2		P
	Components that have been previously tested and shown to comply with the resistance to fire requirements in the standard for the relevant component need not be retested provided that:		--
	- the severity specified in the component standard is not less than the severity specified in 30.2, and		N/A
	- the test report for the component states whether it complied with the standard for the relevant component with or without flame, flames not exceeding 2 s during the test are ignored		N/A
	Unless components have been previously tested and found to comply with the relevant standard for the number of cycles specified, they are tested in accordance with 24.1.1 to 24.1.9		N/A
	For components mentioned in 24.1.1 to 24.1.9, no additional tests specified in the relevant standard for the component are necessary other than those specified in 24.1.1 to 24.1.9		N/A
	Components that have not been separately tested and found to comply with the relevant standard, and		P
	components that are not marked or not used in accordance with their marking,		P
	are tested in accordance with the conditions occurring in the appliance, the number of samples being that required by the relevant standard		P
	Lamp holders and starter holders that have not been previously tested and found to comply with the relevant standard are tested as a part of the appliance and additionally comply with the gauging and interchangeability requirements of the relevant standard under the conditions occurring in the appliance		N/A
	Where the relevant standard specifies these gauging and interchangeability requirements at elevated temperatures, the temperatures measured during the tests of Clause 11 are used		N/A
	Plugs and socket-outlets and other connecting devices of interconnection cords are not interchangeable with plugs and socket-outlets listed in IEC/TR 60083 or IEC 60906-1, or		N/A

Attachment 2

Clause	Requirement - Test	Result - Remark	Verdict
	with connectors and appliance inlets complying with the standard sheets of IEC 60320-1,		N/A
	if direct supply to these parts from the supply mains gives rise to a hazard		N/A
24.1.7	If the remote operation of the appliance is via a telecommunication network, the relevant standard for the telecommunication interface circuitry in the appliance is EN 41003		N/A
	Compliance with Clause 8 of this standard is not impaired by connecting the appliance to a device covered by EN 41003		N/A
24.Z1	For motor running capacitors (IEC 60252-1 type P2) with a metallic enclosure having an overpressure fuse the flame testing of internal plastic parts supporting current carrying connections as required in 30.2.2 and 30.2.3.1 is not necessary		N/A
25.6	Supply cords of single-phase portable appliances having a rated current not exceeding 16 A, fitted with a plug complying with the following standard sheets of IEC/TR 60083:		--
	- for Class I appliances: standard sheet C2b, C3b or C4	C4	P
	- for Class II appliances: standard sheet C5 or C6		N/A
25.7	Rubber sheathed cords (60245 IEC 53) are not suitable for appliances intended to be used outdoors or when they are liable to be exposed to significant amount of ultraviolet radiation		N/A
	Halogen-free thermoplastic compound sheathed supply cords have properties at least those of:		--
	<ul style="list-style-type: none"> halogen-free thermoplastic compound sheathed cords (H03Z1Z1H2-F or H03Z1Z1-F), for appliances having a mass not exceeding 3 kg 		N/A
	<ul style="list-style-type: none"> halogen-free thermoplastic compound sheathed cords (H05Z1Z1H2-F or H05Z1Z1-F), for other appliances 		N/A
	Cross-linked halogen-free compound sheathed supply cords have properties at least those of cross-linked halogen-free compound sheathed cords (H07ZZ-F)		N/A

Attachment 2

Clause	Requirement - Test	Result - Remark	Verdict
26.11	Conductors connected by soldering are not considered to be positioned or fixed so that reliance is not placed upon the soldering alone to maintain them in position unless they are held in place near the terminals independently of the solder		P
29.3.Z1	Appliance constructed so that if there is a possibility of damaging the insulation during installation, the insulation withstands the scratch and penetration test of 21.2		N/A
32	Compliance regarding electromagnetic fields is checked according to EN 50366 or EN 62233	EN 62233	P
Annex AA AA.7.1	When the provisions of footnote a to Table Z101 apply, the appliance shall be marked with: - the substance of "CAUTION: Hot surface"; or - symbol IEC 60417-5041. The warning shall be put on the surface of the appliance having the highest temperature and shall be visible during normal operation. (EN 60335-2-25)		N/A
AA.7.6	[symbol IEC 60417-5041] Caution, hot surface (EN 60335-2-25)		N/A
AA7.14	The height of the warning "CAUTION. Hot surface" shall be at least 4 mm (measured on the capital letters) (EN 60335-2-25)		N/A
	The height of the symbol IEC 60417-5041 shall be at least 12 mm.		N/A
Annex I, 19.I.101	The appliance is supplied at rated voltage and operated under normal operation with each of the fault conditions specified		N/A
	The duration of the test is as specified in 19.7		N/A

Attachment 2

Clause	Requirement - Test	Result - Remark	Verdict
ZA	ANNEX ZA (NORMATIVE) SPECIAL NATIONAL CONDITIONS		--
	Norway		--
19.5	The test is also applicable to appliances intended to be permanently connected to fixed wiring		Not checked
	Norway		--
22.2	The second paragraph of this subclause, dealing with single-phase, permanently connected class I appliances having heating elements, is not applicable due to the supply system		Not checked
	All CENELEC countries		--
25.6 and 25.25	Information concerning National plug and socket-outlets is available from the CENELEC website. Normative national requirements concerning plug and socket-outlets are shown in the relevant National standard		P
	Ireland and United Kingdom		--
25.8	In the table, the lines for 10 A and 16 A are replaced by:		Not checked
	> 10 and ≤ 13 1,25		Not checked
	> 13 and ≤ 16 1,5		Not checked
ZB	ANNEX ZB (INFORMATIVE) A-DEVIATIONS		--
	Ireland		--
25.6	These regulations apply to all plugs for domestic use at a voltage of not less than 200 V and in general allow only plugs complying with I.S. 401:1997, or equivalent, to be fitted to domestic appliances		Not checked
	United Kingdom		--
25.6	These regulations apply to all plugs for domestic use at a voltage of not less than 200 V and in general allow only plugs to BS 1363 to be fitted to domestic appliances. It also allows plugs to BS 4573 and EN 50075 to be fitted to shavers and toothbrushes		Not checked
ZC	ANNEX ZC (NORMATIVE) NORMATIVE REFERENCES TO INTERNATIONAL PUBLICATIONS WITH THEIR CORRESPONDING EUROPEAN PUBLICATIONS		--

Attachment 2

Clause	Requirement - Test	Result - Remark	Verdict
	A list of referenced documents in this standard		P
ZD	ANNEX ZD (INFORMATIVE) IEC and CENELEC CODE DESIGNATIONS FOR FLEXIBLE CORDS		--
	A table with IEC and CENELEC code designations for flexible cords		P
ZE	ANNEX ZE (INFORMATIVE) SPECIFIC ADDITIONAL REQUIREMENTS FOR APPLIANCES AND MACHINES INTENDED FOR COMMERCIAL USE		--
7.1	Business name and full address of the manufacturer and, where applicable, his authorized representative.....:		N/A
	Model or type reference		N/A
	Serial number, if any		N/A
	Production year		N/A
	Designation of the appliance.....:		N/A
7.12	Instructions provided with the appliance so that the appliance can be used safely		N/A
	The instructions contain at least the following information:		--
	- the business name and full address of the manufacturer and, where applicable, his authorized representative		N/A
	- model or type reference of the appliance as marked on the appliance itself, except for the serial number		N/A
	- the designation of the appliance together with its explanation in case it is given by a combination of letters and/or numbers		N/A
	- the general description of the appliance, when needed due to the complexity of the appliance		N/A
	- specific precautions if required during installation, operation, adjusting, user maintenance, cleaning, repairing or moving		N/A
	- when needed drawings, diagrams, descriptions and explanations necessary for the safe use and user maintenance of the appliance		N/A
	- the possible reasonably foreseeable misuse and, whenever relevant, a warning against the effects it may have on the safe use of the appliance		N/A
	The words "Original instructions" appear on the language version(s) verified by the manufacturer or by the authorized representative		N/A

Attachment 2

Clause	Requirement - Test	Result - Remark	Verdict
	When a translation of the original instructions has been provided by a person introducing the appliance on the market; the meaning of the sentence "Translation of the original instructions" appear in the relevant instructions delivered with the appliance		N/A
	The instructions for maintenance/service to be done by specialized personnel, mandated by the manufacturer or the authorized representative may be supplied in only one Community language which the specialized personnel understand		N/A
	The instructions indicate the type and frequency of inspections and maintenance required for safe operation including the preventive maintenance measures		N/A
7.12.ZE1	If needed for specific appliances, the following information to be given:		--
	<ul style="list-style-type: none"> on use, transportation, assembly, dismantling when out of service, testing or foreseeable breakdowns, if these operations have consequences on stability of the appliance in order to avoid overturning, falling or uncontrolled movements of the appliance or of its component parts 		N/A
	<ul style="list-style-type: none"> on how to maintain adequate mechanical stability when in use, during transportation, assembly, dismantling, scrapping and any other action involving the appliance 		N/A
	<ul style="list-style-type: none"> on the protective measures to be taken by the user, including, where appropriate, the personal protective equipment to be provided 		N/A
	<ul style="list-style-type: none"> on the operating method to be followed in the event of accident or breakdown; if a blockage is likely to occur the operating method to safely unblock the appliance 		N/A
	<ul style="list-style-type: none"> on the specifications on the spare parts to be used, when these affect the health and safety of the operator 		N/A
	<ul style="list-style-type: none"> on airborne noise emissions, determined and declared in accordance with the relevant Part 2, which includes: 		--
	<ul style="list-style-type: none"> - the A-weighted emission sound pressure level at workstations, where this exceeds 70 dB(A) 		N/A

Attachment 2

Clause	Requirement - Test	Result - Remark	Verdict
	- where this level does not exceed 70 dB(A), this fact is indicated		N/A
	- the peak C-weighted instantaneous sound pressure value at workstations, where this exceeds 63 Pa (130 dB in relation to 20 µPa).....:		N/A
	- the A-weighted sound power level emitted by the machinery, where the A-weighted emission sound pressure level at workstations exceeds 80 dB(A)		N/A
7.12.ZE2	The instructions includes a warning to disconnect the appliance from its power source during service and when replacing parts		N/A
	If the removal of the plug is foreseen, it is clearly indicated that the removal of the plug has to be such that an operator can check from any of the points to which he has access that the plug remains removed		N/A
	If this is not possible, due to the construction of the appliance or its installation, a disconnection with a locking system in the isolated position is provided		N/A
19.11.4.8	The appliance continues to operate, without causing any hazard to the user, from the same point in its operating cycle at which the voltage fluctuation occurred, or		N/A
	a manual operation is required to restart it		N/A
20.1	Appliances and their components and fittings have adequate mechanical stability during transportation, assembly, dismantling and any other action involving the appliance		N/A
20.2	Dangerous moving transmission parts safeguarded either by design or guards		N/A
	When guards are used, they are fixed guards, interlocking movable guards or protective devices		N/A
	Moving parts directly involved in the function of the appliance which cannot be made completely inaccessible fitted with:		--
	- fixed guards or interlocking movable guards preventing access to those sections of the parts that are not used in the work, and		N/A
	- adjustable guards restricting access to those sections of the moving parts where access is necessary		N/A

Attachment 2

Clause	Requirement - Test	Result - Remark	Verdict
	Interlocking movable guards used where frequent access is required		N/A
21.1	Appliances and their components and fittings have adequate mechanical strength and is constructed to withstand such rough handling that may be expected in normal use, during transportation, assembly, dismantling, scrapping and any other action involving the appliance		N/A
22.ZE.1	For appliances provided with a seat, the seat gives adequate stability		N/A
	The distance between the seat and the control devices capable of being adapted to the operator		N/A
22.ZE.2	For appliances provided with separate devices for the start and the stop functions, the stop function is unambiguously identifiable and does always override the start function		N/A
	For appliances provided with one device performing the start and the stop function, the stop function is unambiguously identifiable and does always override the start function		N/A
22.ZE.3	Appliances designed in such a way that incorrect mounting is avoided, if this can lead to an unsafe situation		N/A
	If this is not possible, information on the correct mounting is given directly on the part and/or the enclosure		N/A
22.ZE.4	Where the weight, size or shape prevents appliances from being moved manually, they are fitted with attachments for lifting gear, or		N/A
	so designed that they can be fitted with such attachments, or		N/A
	be shaped in such a way that standard lifting gear can easily be used		N/A
	Appliances to be moved manually are constructed or equipped so that they can be moved easily and safely		N/A
22.ZE.5	The fixing systems of fixed guards which prevent access to dangerous moving transmission parts only removable with the use of tools		N/A
	If such guards have to be removed by the user for routine cleaning or maintenance their fixing systems remain attached to the fixed guards or to the machine after removal		N/A

Attachment 2

Clause	Requirement - Test	Result - Remark	Verdict
	Where possible, guards are incapable of remaining in place without their fixings		N/A
	This does not apply if, after removal of the screws, or if the component is incorrectly repositioned, the appliance becomes inoperative		N/A
	Movable guards are interlocked		N/A
	The interlocking devices prevent the start of hazardous appliance functions until the guards are fixed in their position, and give a stop command whenever they are no longer closed		N/A
	Where it is possible for an operator to reach the danger zone before the risk due to hazardous appliance functions has ceased, movable guards associated with a guard locking device in addition to an interlocking device that:		--
	- prevents the start of hazardous appliance functions until the guard is closed and locked, and		N/A
	- keeps the guard closed and locked until the risk of injury from the hazardous appliance functions has ceased		N/A
	Interlocking movable guards remain attached to the appliance when open, and		N/A
	they are designed and constructed in such a way that they can be adjusted only by means of an intentional action		N/A
22.ZE.6	Interlocking movable guards designed in such a way that the absence or failure of one of their components prevents starting or stops the hazardous appliance functions		N/A
	The guard is opened to the extent needed to cause the interlocking to operate and is then closed, the number of operations being defined in the specific Part 2.....:		N/A
	After this test any defect that may be expected in normal use is applied to the interlock system, including interruption of the supply, only one defect being simulated at a time		N/A
	After these tests the interlock system is fit for further use		N/A
22.ZE.7	Adjustable guards restricting access to areas of the moving parts strictly necessary for the work are:		--
	- adjustable manually or automatically, depending on the type of work involved, and		N/A
	- readily adjustable without the use of tools		N/A

Attachment 2

Clause	Requirement - Test	Result - Remark	Verdict
22.ZE.8	In case of interruption, re-establishment after an interruption or fluctuation in whatever manner of the power supply, the appliance does not restart		N/A
	However, automatic restarting of the operation is allowed if the appliance may continue to operate, without causing any hazard to the user, from the same point in its operating cycle at which the voltage interruption or fluctuation occurred		N/A
22.ZE.9	Appliances fitted with means to isolate them from all energy sources		N/A
	Such isolators are clearly identified, and		N/A
	they are capable of being locked if reconnection endanger persons		N/A
	After the energy source is disconnected, it is possible to dissipate any energy remaining or stored in the circuits of the appliance without risk to persons		N/A
ZF	ANNEX ZF (INFORMATIVE) CRITERIA APPLIED FOR THE ALLOCATION OF PRODUCTS COVERED BY STANDARDS IN THE EN 60335 SERIES UNDER LVD OR MD		--
	List of standards under CENELEC/TC61 with the allocation under the LVD (Low Voltage Directive) or the MD (Machinery Directive).....:		P
ZG	ANNEX ZG (NORMATIVE) UV APPLIANCES		--
	The following modifications to this standard apply to appliances having UV emitters		N/A
	This annex is not applicable to appliances covered by the scopes of IEC 60335-2-27, IEC 60335-2-59 or IEC 60335-2-109		N/A
7.12.ZG	The instructions for appliances incorporating UVC emitters include the substance of the following: WARNING — This appliance contains a UV emitter. Do not stare at the light source		N/A
32	For appliances incorporating UV emitters the manufacturer delivers a declaration providing evidence that the plastic material exposed to the radiation is UV resistant		N/A
ZZ	ANNEX ZZ (INFORMATIVE) COVERAGE OF ESSENTIAL REQUIREMENTS OF EC DIRECTIVES		--

Attachment 2

Clause	Requirement - Test	Result - Remark	Verdict
	Description of the relation between this European standard and the LVD (Low Voltage Directive, 2006/95/EC) and the MD (Machinery Directive, 2006/42/EC)		P

Annex EN 62233:2008			
Clause	Requirement + Test	Result - Remark	Verdict
EMF- ELECTROMAGNETICS FIELDS			
	The tested product also complies with the requirements of EN 62233:2008		P
	Limit100%	Measured max. : 2,186 %	P

11.8 a	TABLE: Temperature rise for accessible surfaces for model P70T20AL-V2A		P
	Test voltage (V).....:	254,4	—
	Ambient (°C).....:	22,3 / 22,5	—
Surfaces	Surfaces of appliances likely to be touched		
	ΔT (K)	Max. ΔT (K)	
Door glass	26,1	60	
Door frame	20,5	65	
Control panel plastic	15,2	65	
Enclosure metal	34,8	45	

11.8 b	TABLE: Temperature rise for accessible surfaces for model P70T20L-V1A		P
	Test voltage (V).....:	254,4	—
	Ambient (°C).....:	23,3 / 23,6	—
Surfaces	Surfaces of appliances likely to be touched		
	ΔT (K)	Max. ΔT (K)	
Door glass	29,7	60	
Door frame	30,7	65	
Control panel plastic	32,3	65	
Enclosure metal	32,9	45	

---End of Attachment 2---

EN 60335-1: 2012 /A13: 2017			
Clause	Requirement - Test	Result - Remark	Verdict

ATTACHMENT TO TEST REPORT EN 60335-1 Household and similar electrical appliances – Safety – Part 1: General requirements	
Differences according to	EN 60335-1: 2012 /A13: 2017
Attachment Form No.	EN 60335_1
Attachment Originator	SGS-CSTC
Master Attachment	Date 2018-01

Annex ZC	Replace Annex ZC of EN 60335-1:2012	P
Replace Annex ZZ of EN 60335-1:2012 with Annex ZZA& ZZB		P
Annex ZZA	(informative) Relationship between this European standard and the safety objectives of Directive 2014/35/EU [2014 OJ L96] aimed to be covered	P
Annex ZZB	(informative) Relationship between this European standard and the essential requirements of Directive 2006/42/EC aimed to be covered	P

--End of this Attachment--

Attachment 4

Photo documentation

Type of equipment, model: P70T20(x)(y)*#
(x) = L, SL, TL, P, SP, TP, AL, ASL, ATL, AP, ASP, ATP
(y) = -V1, -V2, -V3, -V4, -V5, -V6, -V7, -V8;
*= Blank, A, B, C, D, E, F, G, H, I, J, K, L, M, N, O, P;
#= Blank, A, B, C, D, E, F, G, H, I

Details of: Front view, P70T20AL-V2A

View:

- general
- front
- rear
- right
- left
- top
- bottom



The image shows the front view of a Hamilton Beach microwave oven. The microwave is black with a white control panel on the right side. The control panel features a digital display and several buttons for power, time, and various cooking functions. A wooden ruler is placed vertically to the right of the microwave to provide a scale, showing the microwave is approximately 15 inches high. Another ruler is placed horizontally in front of the microwave, showing it is approximately 18 inches wide. The background is a plain, light-colored surface.

Details of: Rear view (label's location), P70T20AL-V2A

View:

- general
- front
- rear
- right
- left
- top
- bottom

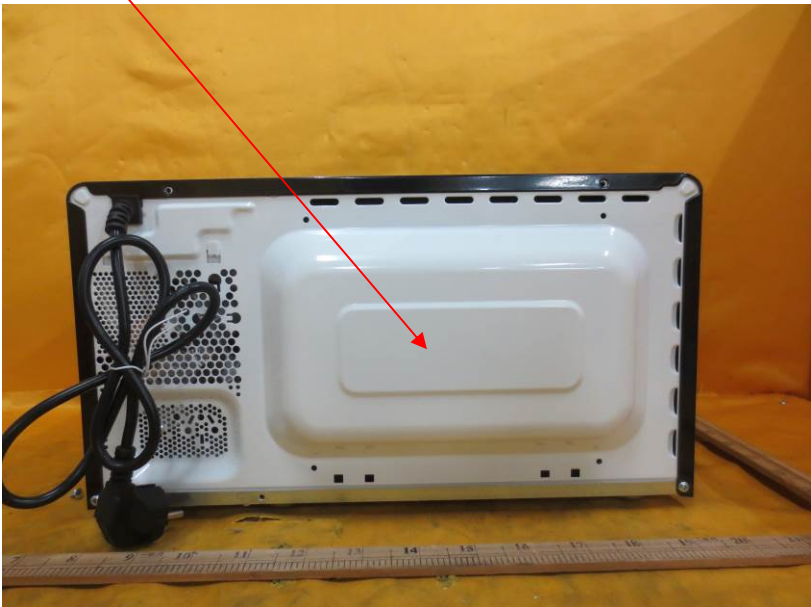

The image shows the rear view of the microwave oven. The back panel is white and features a large rectangular vent area in the center. To the left of the vent, there is a power cord and a power cord reel. A wooden ruler is placed horizontally at the bottom of the image for scale, showing the microwave is approximately 18 inches wide. A red arrow points from the top of the image down to a small, rectangular label located on the right side of the back panel, just above the vent area. The background is a plain, light-colored surface.

Attachment 4

Details of: Right view, P70T20AL-V2A

View:

- general
- front
- rear
- right
- left
- top
- bottom



Details of: Left view, P70T20AL-V2A

View:

- general
- front
- rear
- right
- left
- top
- bottom



Attachment 4

Details of: Top view, P70T20AL-V2A

View:

- general
- front
- rear
- right
- left
- top
- bottom



Details of: Bottom view, P70T20AL-V2A

View:

- general
- front
- rear
- right
- left
- top
- bottom



Attachment 4

Details of: Control panel, P70T20AL-V2A

View:

- general
- front
- rear
- right
- left
- top
- bottom



Details of: Cavity, P70T20AL-V2A

View:

- general
- front
- rear
- right
- left
- top
- bottom



Attachment 4

Details of: Internal view, P70T20AL-V2A

View:

- general
- front
- rear
- right
- left
- top
- bottom



Details of: Internal view, P70T20AL-V2A

View:

- general
- front
- rear
- right
- left
- top
- bottom



Attachment 4

Details of: Internal view, P70T20AL-V2A

View:

- general
- front
- rear
- right
- left
- top
- bottom



Details of: Internal view, P70T20AL-V2A

View:

- general
- front
- rear
- right
- left
- top
- bottom



Attachment 4

Details of: Internal view, P70T20AL-V2A

View:

- general
- front
- rear
- right
- left
- top
- bottom



Details of: Earthed terminal and symbol, P70T20AL-V2A

View:

- general
- front
- rear
- right
- left
- top
- bottom

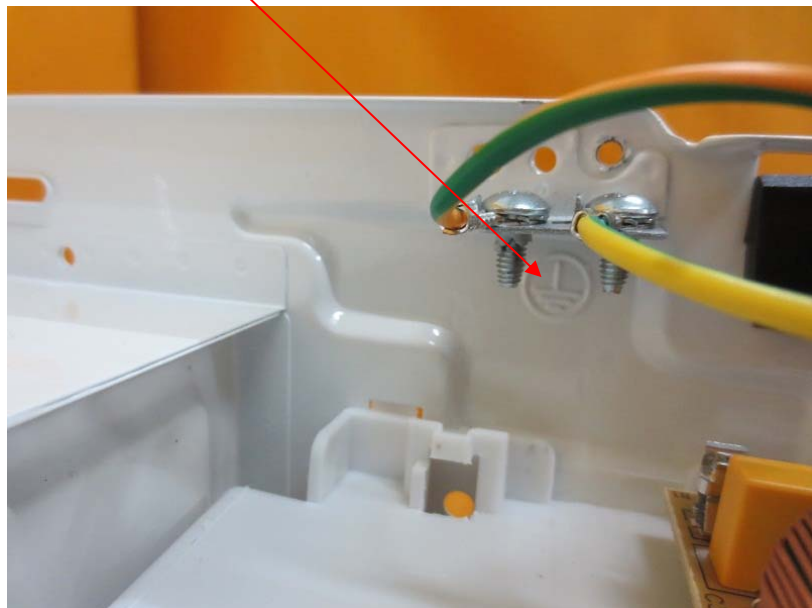

Attachment 4

Details of: Front view, P70T20P-V1A

View:

- general
- front
- rear
- right
- left
- top
- bottom



Details of: Rear view (label's location), P70T20P-V1A

View:

- general
- front
- rear
- right
- left
- top
- bottom



Attachment 4

Details of: Right view, P70T20P-V1A

View:

- general
- front
- rear
- right
- left
- top
- bottom



Details of: Left view, P70T20P-V1A

View:

- general
- front
- rear
- right
- left
- top
- bottom



Attachment 4

Details of: Top view, P70T20P-V1A

View:

- general
- front
- rear
- right
- left
- top
- bottom



Details of: Bottom view, P70T20P-V1A

View:

- general
- front
- rear
- right
- left
- top
- bottom



Attachment 4

Details of: Control panel, P70T20P-V1A

View:

- general
- front
- rear
- right
- left
- top
- bottom



Details of: Cavity, P70T20P-V1A

View:

- general
- front
- rear
- right
- left
- top
- bottom



Attachment 4

Details of: Internal view, P70T20P-V1A

View:

- general
- front
- rear
- right
- left
- top
- bottom

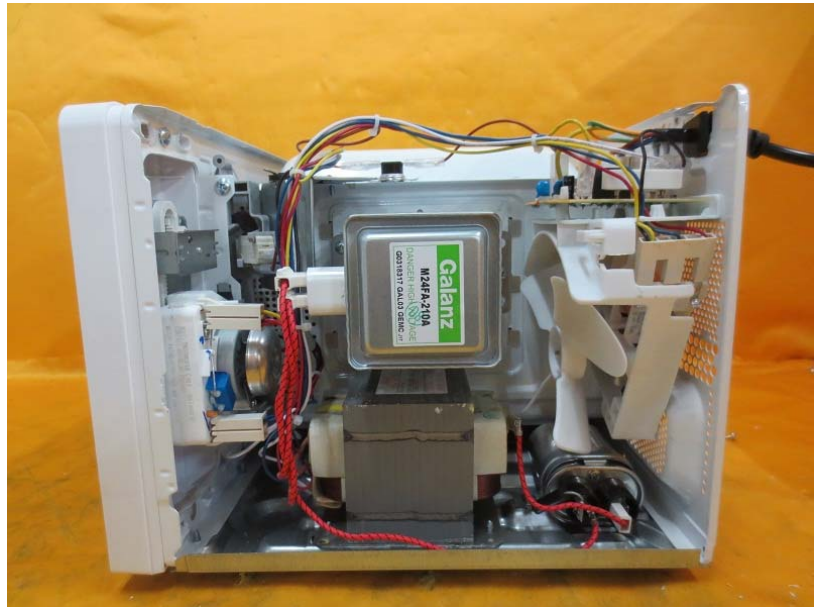

Details of: Internal view, P70T20P-V1A

View:

- general
- front
- rear
- right
- left
- top
- bottom

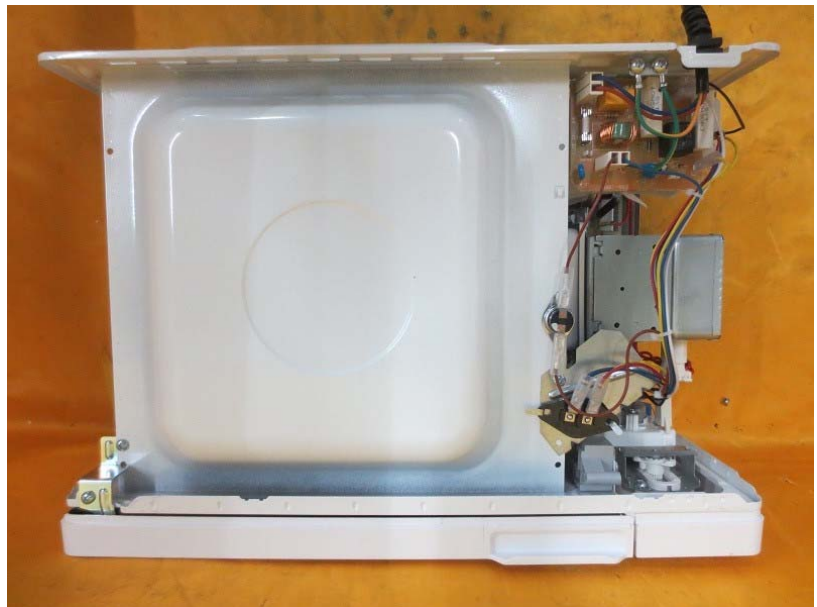

Attachment 4

Details of: Internal view, P70T20P-V1A

View:

- general
- front
- rear
- right
- left
- top
- bottom



Details of: Internal view, P70T20P-V1A

View:

- general
- front
- rear
- right
- left
- top
- bottom

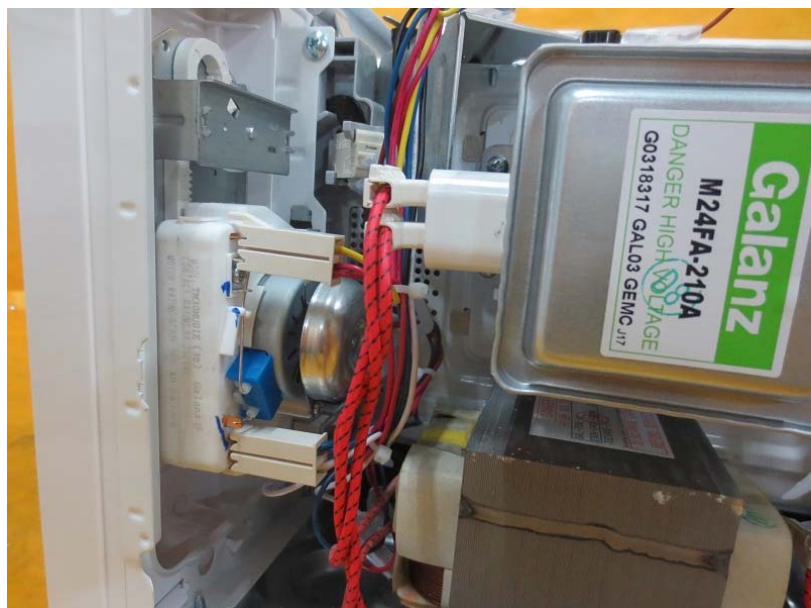

Attachment 4

Details of: Internal view, P70T20P-V1A

View:

- general
- front
- rear
- right
- left
- top
- bottom



Details of: Earthed terminal and symbol, P70T20P-V1A

View:

- general
- front
- rear
- right
- left
- top
- bottom

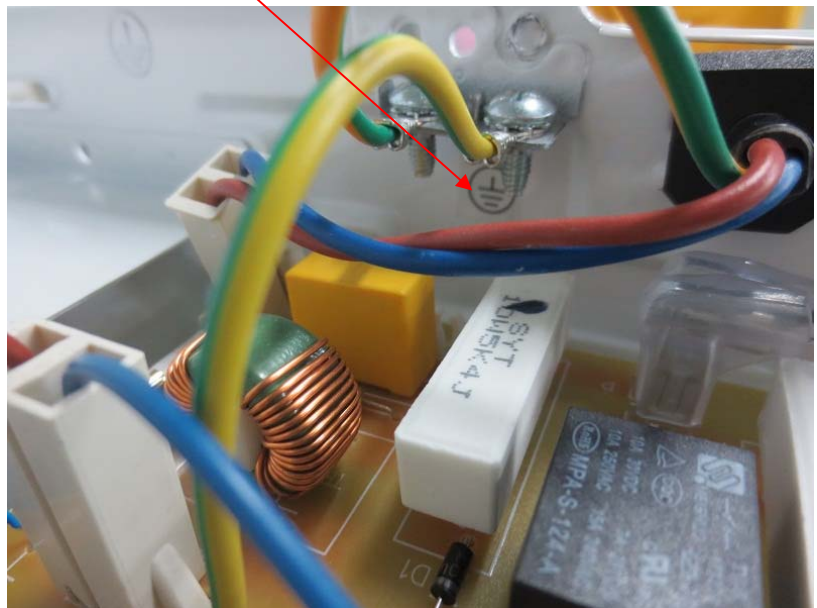

Attachment 4

Details of: H,V, transformer

View:

- general
- front
- rear
- right
- left
- top
- bottom



Details of: Magnetron

View:

- general
- front
- rear
- right
- left
- top
- bottom



Attachment 4

Details of: Fan motor

View:

- general
- front
- rear
- right
- left
- top
- bottom

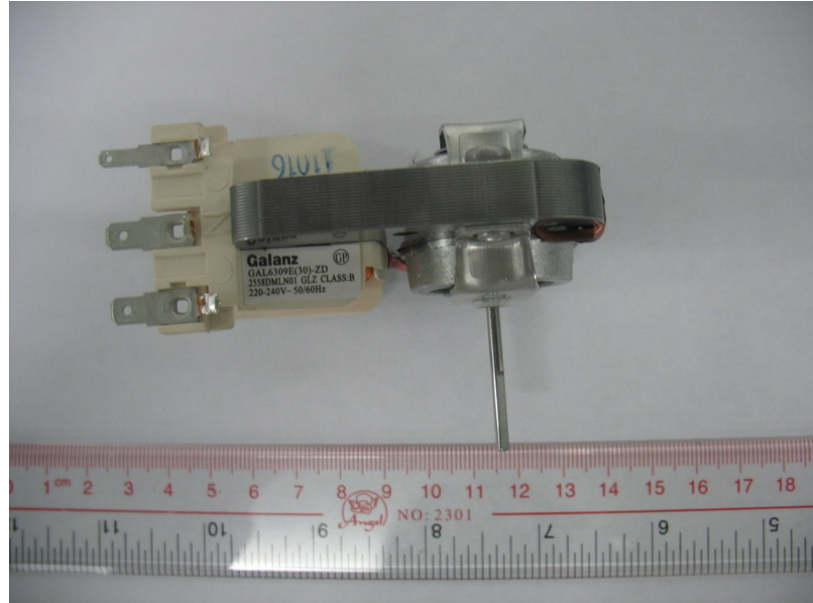

Details of: Turntable motor

View:

- general
- front
- rear
- right
- left
- top
- bottom

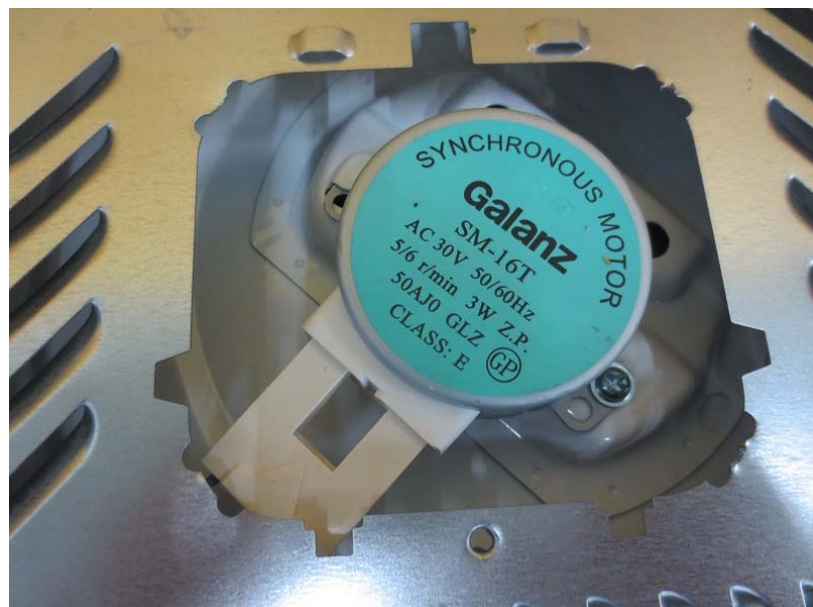

Attachment 4

Details of: H,V, capacitor

View:

- general
- front
- rear
- right
- left
- top
- bottom



Details of: Timer

View:

- general
- front
- rear
- right
- left
- top
- bottom



Attachment 4

Details of: Noise filter PCB FD0-1K20

View:

- general
- front
- rear
- right
- left
- top
- bottom

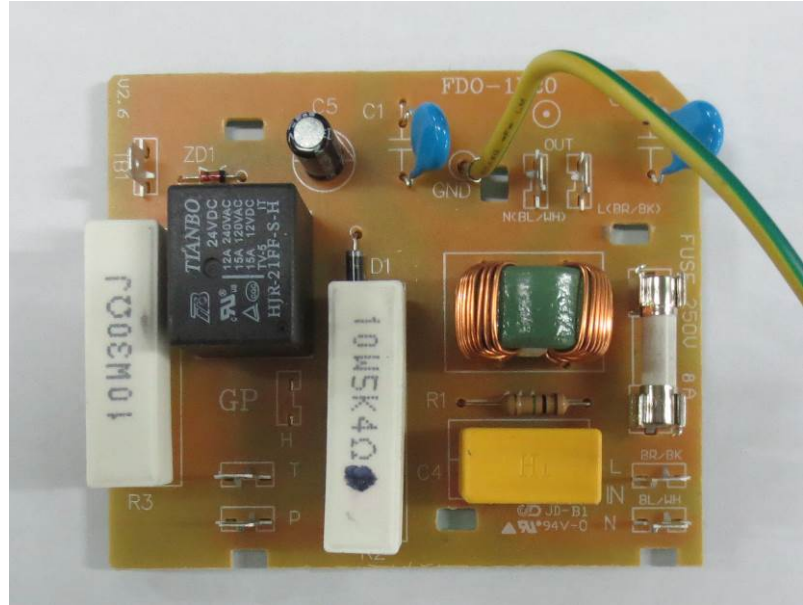

Details of: Noise filter PCB FD0-1K20

View:

- general
- front
- rear
- right
- left
- top
- bottom

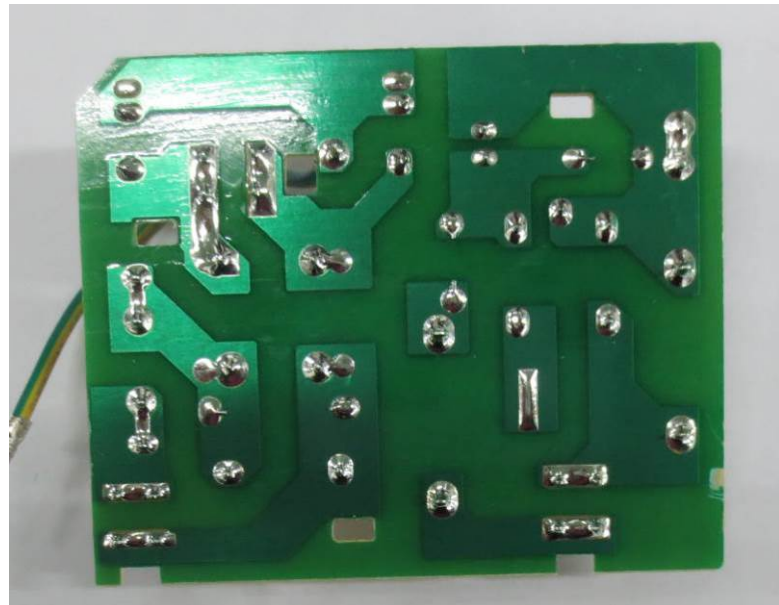

Attachment 4

Details of: Noise filter PCB FD9-1K06

View:

- general
- front
- rear
- right
- left
- top
- bottom



Details of: Noise filter PCB FD9-1K06

View:

- general
- front
- rear
- right
- left
- top
- bottom

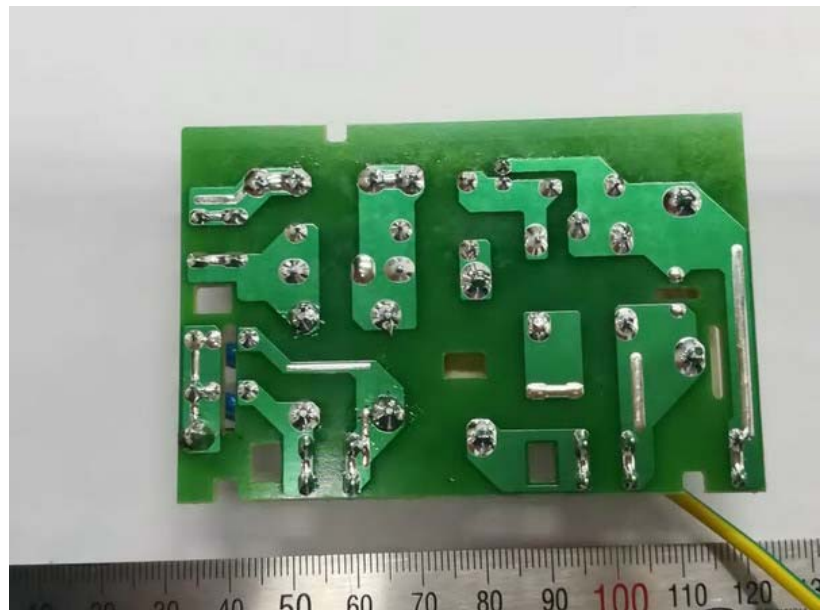

Attachment 4

Details of: Noise filter PCB FN14-1K00

View:

- general
- front
- rear
- right
- left
- top
- bottom

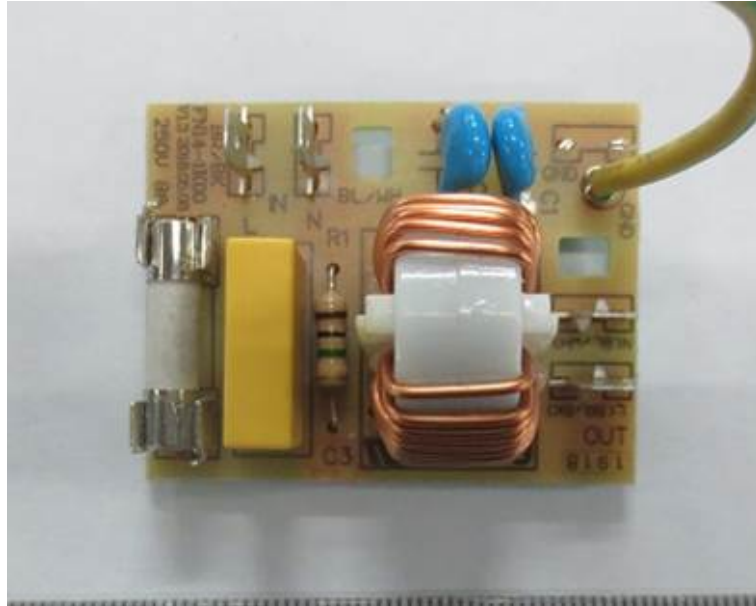

Details of: Noise filter PCB FN14-1K00

View:

- general
- front
- rear
- right
- left
- top
- bottom

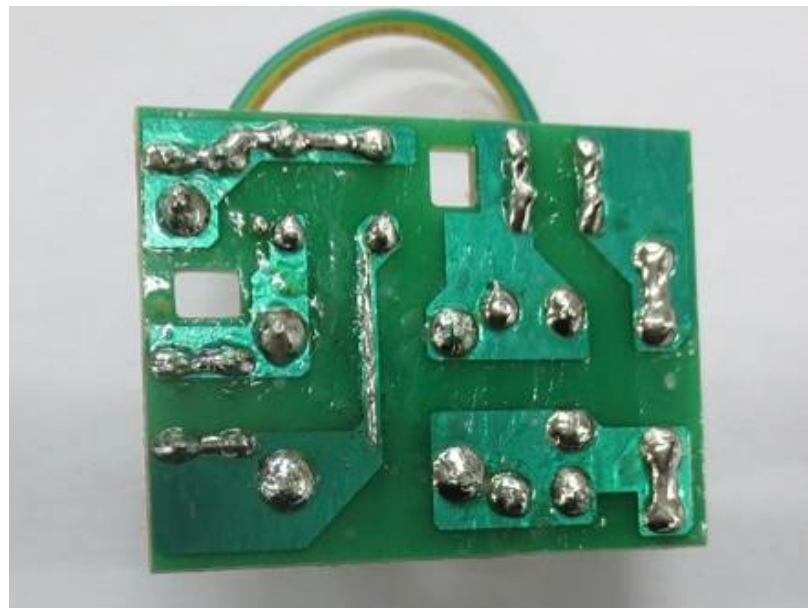

Attachment 4

Details of: Noise filter PCB FN14-1K06

View:

- general
- front
- rear
- right
- left
- top
- bottom

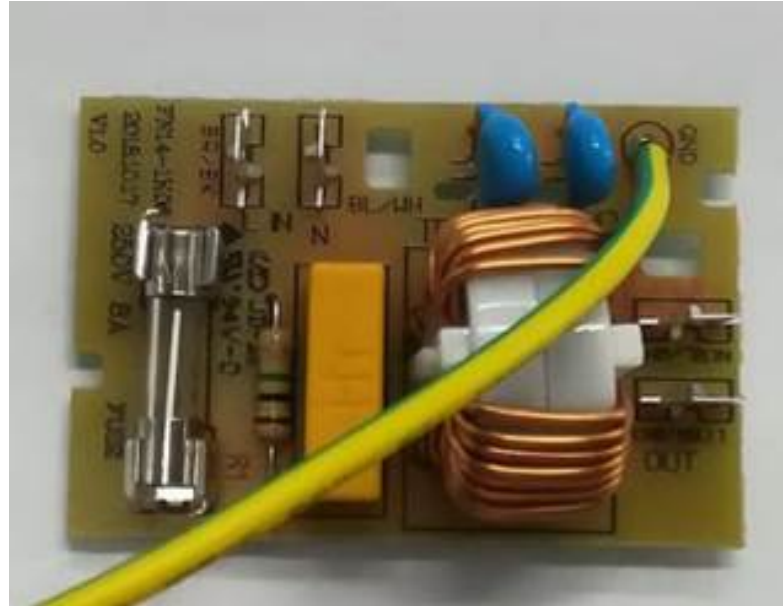

Details of: Noise filter PCB FN14-1K06

View:

- general
- front
- rear
- right
- left
- top
- bottom

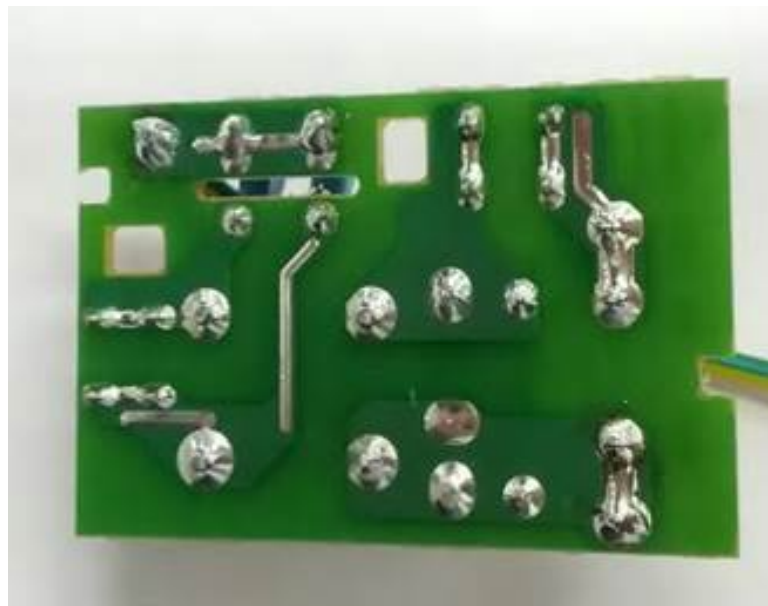

Attachment 4

Details of: Control panel PCB MEL829-S

View:

- general
- front
- rear
- right
- left
- top
- bottom

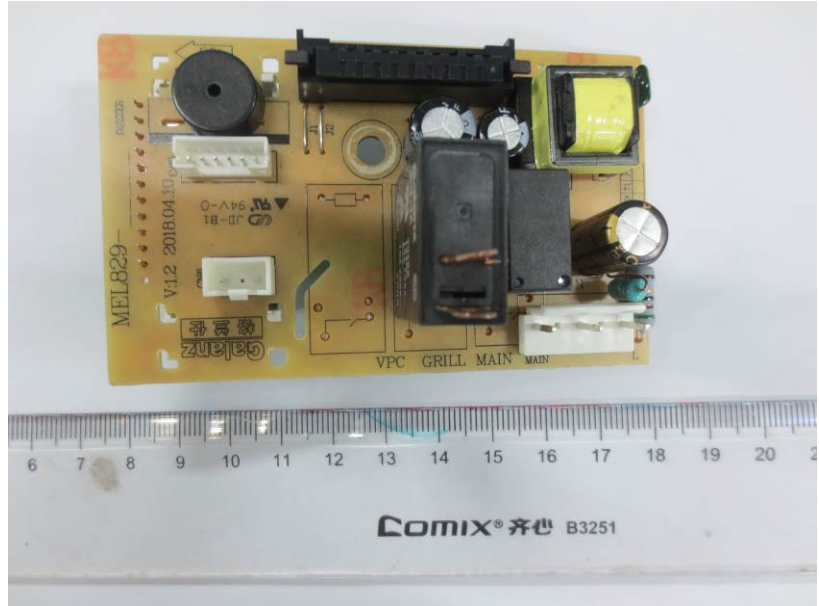

Details of: Control panel PCB MEL829-S

View:

- general
- front
- rear
- right
- left
- top
- bottom

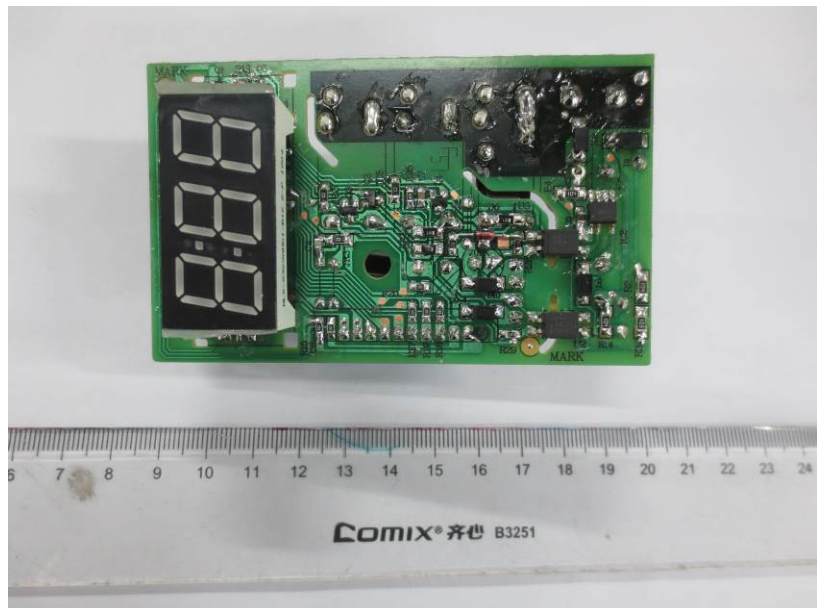

Attachment 4

Details of: Appearance of V3

View:

- general
- front
- rear
- right
- left
- top
- bottom



Details of: Appearance of V4

View:

- general
- front
- rear
- right
- left
- top
- bottom



Attachment 4

Details of: Appearance of V5

View:

- general
- front
- rear
- right
- left
- top
- bottom



Details of: Appearance of V6

View:

- general
- front
- rear
- right
- left
- top
- bottom



Attachment 4

Details of: Appearance of V7

View:

- general
- front
- rear
- right
- left
- top
- bottom



Details of: Appearance of V8

View:

- general
- front
- rear
- right
- left
- top
- bottom



--- End of Attachment 4 ---

Attachment 5

Circuit diagram

Circuit diagram

Mechanical model

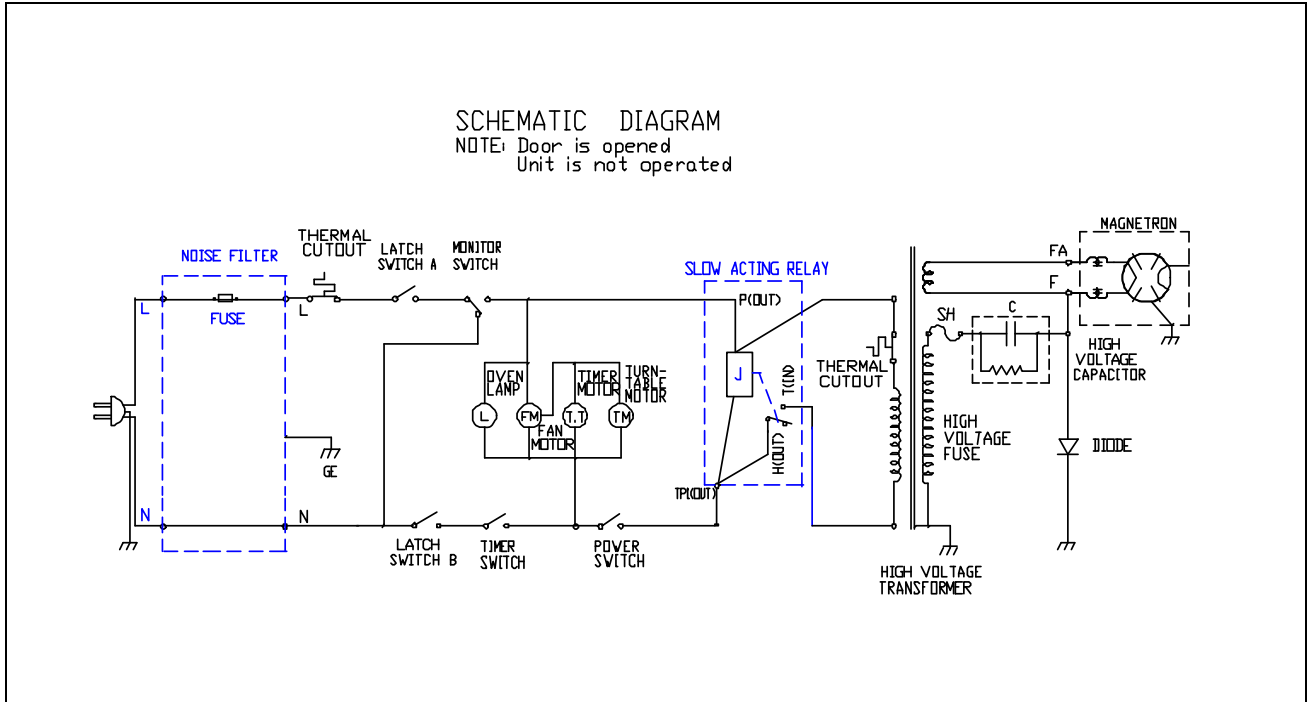

Circuit diagram

Electronic model

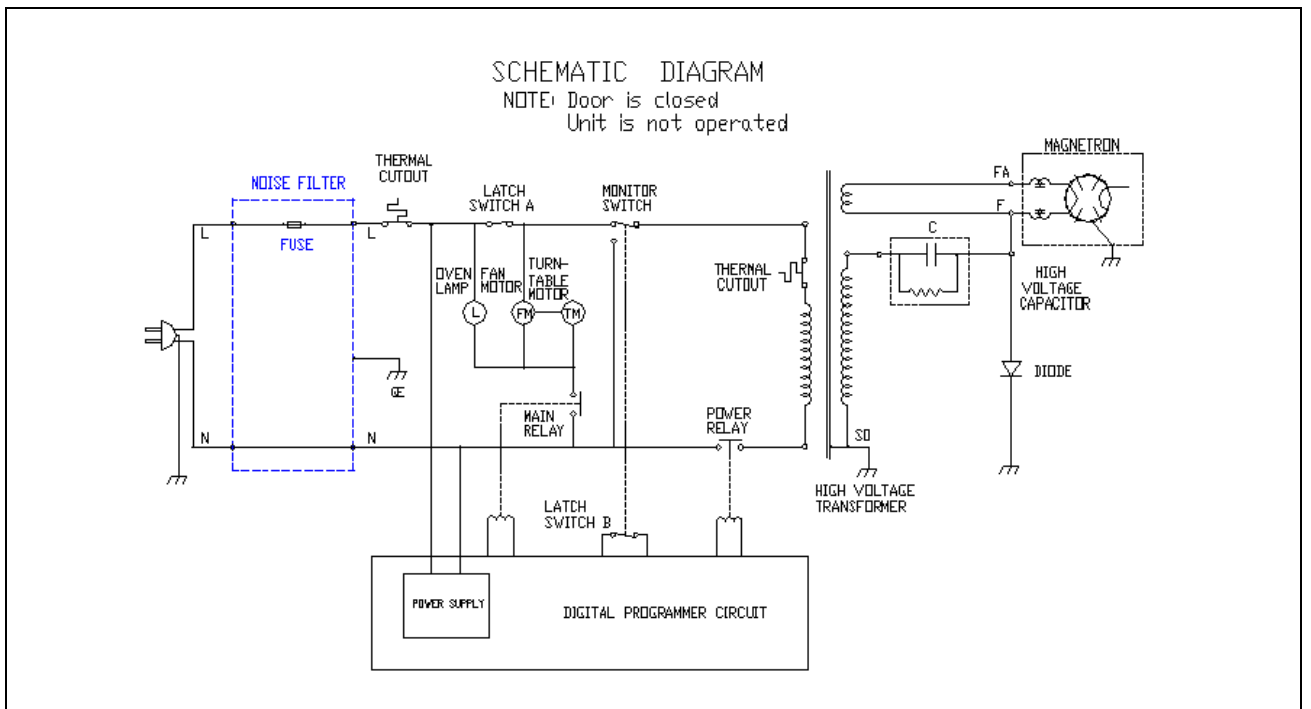

Attachment 5

Circuit diagram Noise filter PCB FD0-1K20, FD9-1K00, FD9-1K09

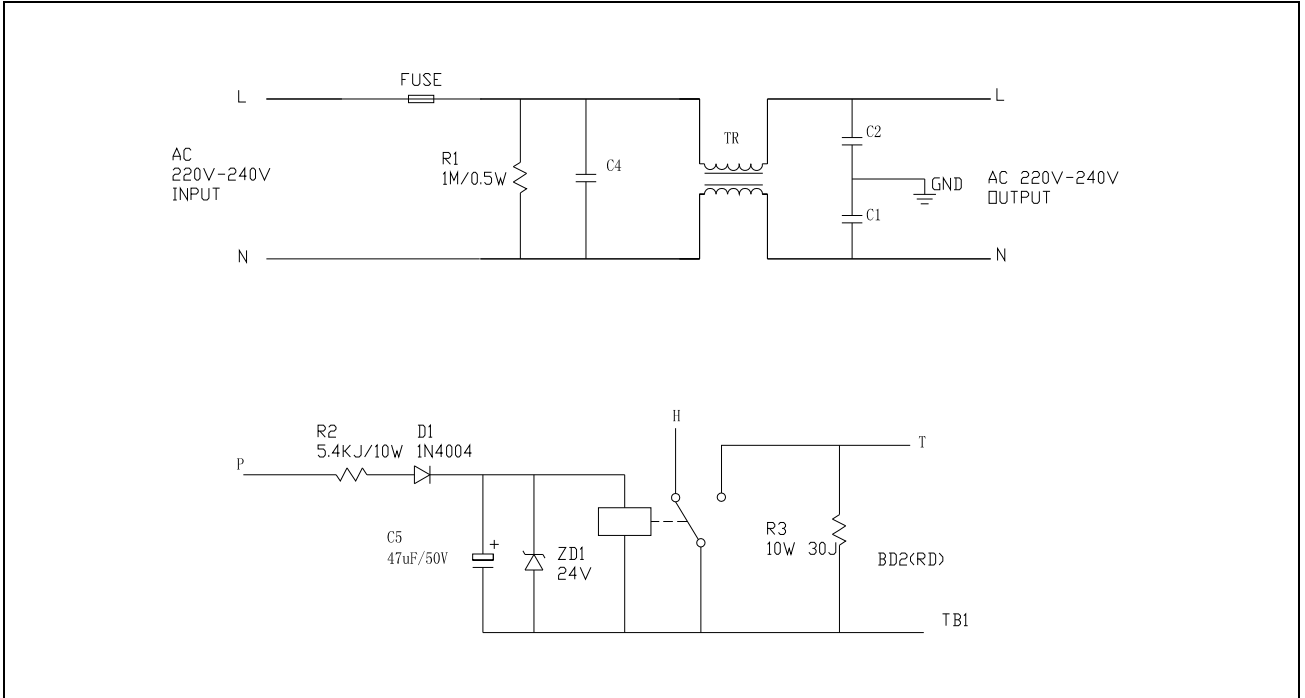

Circuit diagram Noise filter PCB FN14-1K00, FN14-1K06

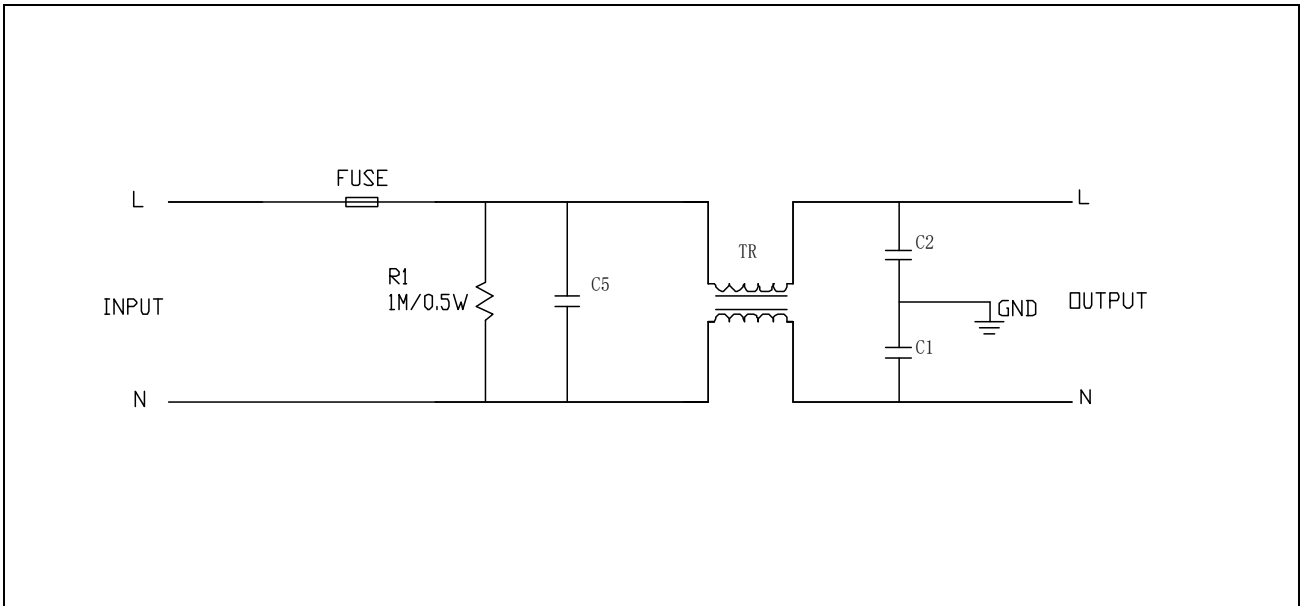

Attachment 5

Circuit diagram Control panel PCB MEL829-S

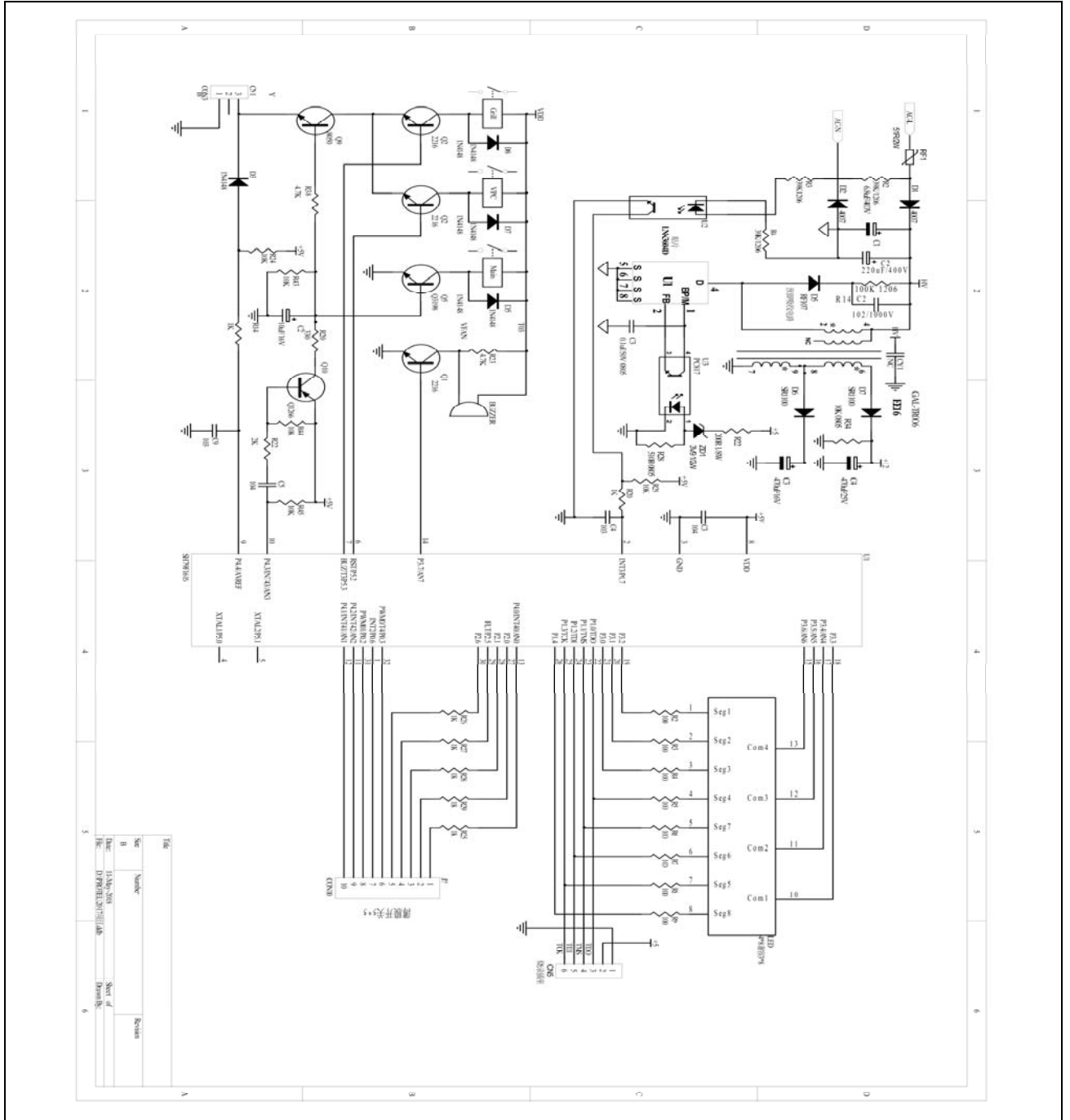

--- End of Attachment 5 ---