



The following sample(s) was/were submitted and identified on behalf of the client as:

TEST REPORT COMMISSION REGULATION (EC) No 1275/2008 & (EU) No 801/2013 Implementing Directive 2009/125/EC of the European Parliament and of the Council with regard to ecodesign requirements for standby, off mode and networked standby electric power consumption of electrical and electronic household and office equipment	
Report Reference No:	GZES181100301731
Tested by (name + signature)	Leif Hong /Project engineer 
Approved by (+ signature)	Sky Lin /Reviewer 
Date of issue.....:	2018-11-13
Total number of pages.....:	16
Testing Laboratory	SGS-CSTC Standards Technical Services Co., Ltd. Shunde Branch
Address.....:	Building 1, European Industrial Park, No.1, Shunhe South Road, Wusha, Daliang, Shunde District, Foshan, Guangdong, China
Applicant's name	Guangdong Gaobo Electrical Appliance Co., Ltd.
Address.....:	Area Gaoling West Industrial Park, Liangdong Town, Lianjiang City, Guangdong, China
Test specification:	
Test procedure	STR: COMMISSION REGULATION (EC) No 1275/2008 & (EU) No 801/2013
Non-standard test method.....:	None
Test Report Form No:	1275/2008/EC_I
Test Report Form(s) Originator	SGS-CSTC
Master TRF.....:	2014-08-13
Copyright @ 2009 SGS-CSTC Standards Technical Services Co., Ltd. (SGS-CSTC), Shenzhen, P.R. China. All rights reserved. This publication may be produced in whole or in part for non-commercial purposes as long as SGS-CSTC is acknowledged as copyright owner and source of the material. SGS-CSTC takes no responsibility for and will not assume liability for damages resulting from the reader's interpretation of the reproduced material due to its placement and context	

Test item description:	Rice cooker
Model/Type reference.....:	See page 4, 5 and 6
Ratings.....:	220 V – 240 V; 50 Hz / 60 Hz; Class I; See page 4, 5 and 6 for rated power
Manufacturing site (factory).....:	Same as applicant
Test item particulars:	
Classification of installation and use	Portable appliance and household use
Supply Connection.....:	Non-detachable power cord fitted with a plug or appliance inlet, see page 6 for details
Networked equipment.....:	No
Availability of Standby mode.....:	No
Availability of off mode.....:	Yes
Availability of display function in standby-mode.....:	No
Availability of any condition which does not exceed the applicable power consumption requirements for off mode and/or standby mode when the equipment is connected to the mains power source.....:	Yes
Availability of power management function.....:	No
Summary of testing:	
Tests performed:	
<p>The sample(s) tested complies with the requirements of COMMISSION REGULATION (EC) No 1275/2008 & (EU) No 801/2013.</p> <p>These tests fulfil the requirements of standard ISO/IEC 17025.</p> <p>When determining the test conclusion, the Measurement Uncertainty of test has been considered.</p> <p>The maximum permitted uncertainty of measurement depends on the size of the load and the characteristics of the load. The key characteristic of the load used to determine the maximum permitted uncertainty is the Maximum Current Ratio (MCR), which is calculated as follows:</p> $\text{Maximum Current Ratio (MCR)} = \frac{\text{Crest Factor (CF)}}{\text{Power Factor (PF)}}$ <p>where</p> <ul style="list-style-type: none"> the Crest Factor (CF) is the measured peak current drawn by the product divided by the measured r.m.s. current drawn by the product; the Power Factor (PF) is a characteristic of the power consumed by the product. It is the ratio of the measured real power to the measured apparent power. <p>a) <u>Permitted uncertainty for values of MCR ≤ 10</u></p> <p>For measured power values of greater than or equal to 1,0 W, the maximum permitted relative uncertainty introduced by the power measurement equipment, U_{mr}, shall be equal to or less than 2 % of the measured power value at the 95 % confidence level.</p> <p>For measured power values of less than 1,0 W, the maximum permitted absolute uncertainty introduced</p>	

by the power measurement equipment, U_{ma} , shall be equal to or less than 0,02 W at the 95 % confidence level.

b) Permitted uncertainty for values of MCR >10

The value of U_{pc} shall be determined using the following equation:

$$U_{pc} = 0,02 \times [1 + (0,08 \times \{MCR - 10\})]$$

where U_{pc} is the maximum permitted relative uncertainty for cases where the MCR is > 10.

For measured power values of greater than or equal to 1,0 W, the maximum permitted relative uncertainty introduced by the power measurement equipment shall be equal to or less than U_{pc} at the 95 % confidence level.

For measured power values of less than 1,0 W, the permitted absolute uncertainty shall be the greater of U_{ma} (0,02 W) or U_{pc} when expressed as an absolute uncertainty in W ($U_{pc} \cdot$ measured value) at the 95 % confidence level.

Copy of marking plate

The artwork below may be only a draft. The use of certification marks on a product must be authorized by the respective NCBs that own these marks.

As declared by the applicant, the importer (and manufacturer, if it is different)'s name, registered trade name or registered trade mark and the postal address will be marked on the products before being place on the market. The contact details shall be in a language easily understood by end-users and market surveillance authorities.

Marking on the packaging or in a document accompanying the electrical equipment is only acceptable if it is not possible to place such markings on the product.

The Height of CE logo shall not be less than 5 mm; Height of WEEE logo shall not be less than 7 mm.

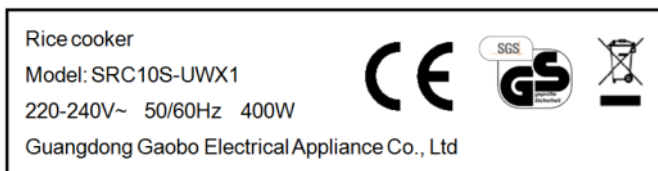

Remark: Other labels are identical with above, except for different model name and ratings.

Possible test case verdicts:	
- test case does not apply to the test object	N (or N/A)
- test object does meet the requirement	P (Pass)
- test object does not meet the requirement	F (Fail)
Testing	
Date of receipt of test item	2018-11-13
Date (s) of performance of tests	2018-11-13
General remarks:	
<p>The test results presented in this report relate only to the object tested. This report shall not be reproduced, except in full, without the written approval of the Issuing testing laboratory. "(see Enclosure #)" refers to additional information appended to the report. "(see appended table)" refers to a table appended to the report.</p> <p>Throughout this report a comma is used as the decimal separator.</p> <p>This document is issued by the Company subject to its General Conditions of Service, available on request or accessible at http://www.sgs.com/en/Terms-and-Conditions.aspx and, for electronic format documents, subject to Terms and Conditions for Electronic Documents at http://www.sgs.com/en/Terms-and-Conditions/Terms-e-Documents.aspx. Attention is drawn to the limitation of liability, indemnification and jurisdiction issues defined therein.</p> <p>Any holder of this document is advised that information contained hereon reflects the Company's findings at the time of its intervention only and within the limits of Client's instructions, if any. The Company's sole responsibility is to its Client and this document does not exonerate parties to a transaction from exercising all their rights and obligations under the transaction documents. This document cannot be reproduced except in full, without prior written approval of the Company. Any unauthorized alteration, forgery or falsification of the content or appearance of this document is unlawful and offenders may be prosecuted to the fullest extent of the law.</p> <p>Unless otherwise stated the results shown in this test report refer only to the sample(s) tested and such sample(s) are retained for 30 days only.</p> <p>This report is only for technical use, for product comply with the full implementing Directive 2009/125/EC, additional information shall be provided by manufacture according to the Commission Regulations.</p>	

General product information:

Rice cooker intended for household and indoor use only.

Model list:

Model	Rated Power (W)	Rated Capacity (L)	Type Y attachment	Appliance inlet	Thermal cut-out	Thermostat (keep warm function)	Keep warm heater
RC03-y	220	0,3L	Yes	Yes	No	No	No
RC06A-xyz	300	0,6L	Yes	Yes	Yes	Yes	Yes
RC06B-xyz	350	0,6L	Yes	Yes	Yes	Yes	Yes
RC08-xyz	350	0,8L	Yes	Yes	Yes	Yes	Yes
RC10A-xyz	400	1,0L	Yes	Yes	Yes	Yes	Yes
RC10B-xyz	450	1,0L	Yes	Yes	Yes	Yes	Yes
RC12A-xyz	400	1,2L	Yes	Yes	Yes	Yes	Yes
RC12B-xyz	450	1,2L	Yes	Yes	Yes	Yes	Yes
RC15A-xyz	500	1,5L	Yes	Yes	Yes	Yes	Yes
RC15B-xyz	550	1,5L	Yes	Yes	Yes	Yes	Yes
RC18A-xyz	700	1,8L	Yes	Yes	Yes	Yes	Yes
RC18B-xyz	650	1,8L	Yes	Yes	Yes	Yes	Yes
RC18C-xyz	750	1,8L	Yes	Yes	Yes	Yes	Yes
RC22A-xyz	900	2,2L/2.5L	Yes	Yes	Yes	Yes	Yes
RC22B-xyz	850	2,2L/2.5L	Yes	Yes	Yes	Yes	Yes
RC28A-xyz	1000	2,8L	Yes	Yes	Yes	Yes	Yes
RC28B-xyz	950	2,8L	Yes	Yes	Yes	Yes	Yes
RC36A-xyz	1300	3,6L	Yes	No	Yes	Yes	No
RC36B-xyz	1250	3,6L	Yes	No	Yes	Yes	No
RC42A-xyz	1600	4,2L	Yes	No	Yes	Yes	No
RC42B-xyz	1550	4,2L	Yes	No	Yes	Yes	No
RC56A-xyz	2000	5,6L	Yes	No	Yes	Yes	No
RC56B-xyz	1950	5,6L	Yes	No	Yes	Yes	No
RC78A-xyz	2200	7,8L	Yes	No	Yes	Yes	No
RC78B-xyz	2250	7,8L	Yes	No	Yes	Yes	No
RC80A-xyz	2500	8,0L	Yes	No	Yes	Yes	No
RC80B-xyz	2250	8,0L	Yes	No	Yes	Yes	No
RC85A-xyz	2800	8,5L	Yes	No	Yes	Yes	No
RC85B-xyz	2650	8,5L	Yes	No	Yes	Yes	No
RC100A-xyz	3000	10L	Yes	No	Yes	Yes	No
RC100B-xyz	3200	10L	Yes	No	Yes	Yes	No
RC120A-xyz	3500	12L	Yes	No	Yes	Yes	No
RC120B-xyz	3250	12L	Yes	No	Yes	Yes	No
SRC06a-xyz	300	0,6L	Yes	Yes	Yes	Yes	Yes
SRC06a1-xyz	350	0,6L	Yes	Yes	Yes	Yes	Yes
SRC10a-xyz	400	1,0L	Yes	Yes	Yes	Yes	Yes
SRC10a1-xyz	450	1,0L	Yes	Yes	Yes	Yes	Yes

SRC12a-*xyz	400	1,2L	Yes	Yes	Yes	Yes	Yes
SRC12a1-*xyz	450	1,2L	Yes	Yes	Yes	Yes	Yes
SRC15a-*xyz	500	1,5L	Yes	Yes	Yes	Yes	Yes
SRC15a1-*xyz	550	1,5L	Yes	Yes	Yes	Yes	Yes
SRC18a-*xyz	700	1,8L	Yes	Yes	Yes	Yes	Yes
SRC18a1-*xyz	650	1,8L	Yes	Yes	Yes	Yes	Yes
SRC18a2-*xyz	600	1,8L	Yes	Yes	Yes	Yes	Yes
SRC22a-*xyz	900	2,2L/2.5L	Yes	Yes	Yes	Yes	Yes
SRC22a1-*xyz	850	2,2L/2.5L	Yes	Yes	Yes	Yes	Yes
SRC28a-*xyz	1000	2,8L	Yes	Yes	Yes	Yes	Yes
SRC28a1-*xyz	950	2,8L	Yes	Yes	Yes	Yes	Yes
DRC10a-*xmz	400	1,0L	No	Yes	Yes	Yes	Yes
DRC10a1-*xmz	450	1,0L	No	Yes	Yes	Yes	Yes
DRC12a-*xmz	400	1,2L	No	Yes	Yes	Yes	Yes
DRC12a1-*xmz	450	1,2L	No	Yes	Yes	Yes	Yes
DRC15a-*xmz	500	1,5L	No	Yes	Yes	Yes	Yes
DRC15a1-*xmz	550	1,5L	No	Yes	Yes	Yes	Yes
DRC18a-*xmz	700	1,8L	No	Yes	Yes	Yes	Yes
DRC18a1-*xmz	650	1,8L	No	Yes	Yes	Yes	Yes
DRC22a-*xmz	900	2,2L/2.5L	No	Yes	Yes	Yes	Yes
DRC22a1-*xmz	850	2,2L/2.5L	No	Yes	Yes	Yes	Yes
DRC28a-*xmz	1100	2,8L	No	Yes	Yes	Yes	Yes
DRC28a1-*xmz	1000	2,8L	No	Yes	Yes	Yes	Yes
DRC28a2-*xmz	950	2,8L	No	Yes	Yes	Yes	Yes
DRC32a-*xmz	1200	3,2L	No	Yes	Yes	Yes	Yes
DRC32a1-*xmz	1250	3,2L	No	Yes	Yes	Yes	Yes
DRC36a-*xmz	1300	3,6L	No	Yes	Yes	Yes	Yes
DRC36a1-*xmz	1250	3,6L	No	Yes	Yes	Yes	Yes

a = C or S, indicates difference bottom enclosure. C means metal enclosure. S means plastic enclosure.

* = A to P, a to y, indicates difference control panel, shown as below.

x = V, W or P, indicates difference pattern of the appearance. V means stainless steel. W means coated steel. P means coated steel with painted pattern.







y = X or Y, indicates difference connection. X means the appliance was with appliance inlet. Y means the appliance was type Y attachment.













m = A to O, indicates difference handle. Detail shown in below.

z = 1, 2 or 3, indicates difference electric circuit. Detail shown in attachment 3.

No keep warm function for models RC03-y.

Detail for different handle:

					
G	H	I	J	K	L

					
M	N	O	--	--	--
					

etail for different control panel:

					
A	B	C	D	E	F
					
G	H	I	J	K	L
					
M	N	O	P	a	b
					
c	d	e	f	g	h
					
i	j	k	l	m	n
					
o	p	q	r	s	t
					
u	v	w	x	y	--
					

After review, RC120A-AY3 was subjected to the test.

COMMISSION REGULATION (EC) No 1275/2008 & (EU) No 801/2013			
ANNEX II Ecodesign requirements			
Cl.	Requirement-Test	Result-Remark	Verdict
1 & 2	Power consumption in 'off mode'		--
1(a) & 2(a)	Power consumption of equipment in any off-mode condition	See appended table 2	P
1(b) & 2(b)	Power consumption in 'standby mode(s)'		--
	The power consumption of equipment in any condition providing only a reactivation function, or providing only a reactivation function and a mere indication of enabled reactivation function		N/A
	The power consumption of equipment in any condition providing only information or status display, or providing only a combination of reactivation function and information or status display		N/A
1(c) & 2(c)	Availability of off mode and/or standby mode		--
	Equipment shall, except where this is inappropriate for the intended use, provide off mode and/or standby mode, and/or another condition which does not exceed the applicable power consumption requirements for off mode and/or standby mode when the equipment is connected to the mains power source		P
2(d)	Power management for all equipment other than networked equipment		--
	When equipment is not providing the main function, or when other energy-using product(s) are not dependent on its functions, equipment shall, unless inappropriate for the intended use, offer a power management function, or a similar function, that switches equipment after the shortest possible period of time appropriate for the intended use of the equipment, automatically into:		N/A
	<ul style="list-style-type: none"> — standby mode, or — off mode, or — Another condition which does not exceed the applicable power consumption requirements for off mode and/or standby mode when the equipment is connected to the mains power source. The power management function shall be activated before delivery 		N/A
3(a)	Any networked equipment that can be connected to a wireless network shall offer the user the possibility to deactivate the wireless network connection(s). This requirement does not apply to products which rely on a single wireless network connection for intended use and have no wired network connection		N/A
3(b)	Power management for networked equipment		--

COMMISSION REGULATION (EC) No 1275/2008 & (EU) No 801/2013			
ANNEX II Ecodesign requirements			
Cl.	Requirement-Test	Result-Remark	Verdict
	Equipment shall, unless inappropriate for the intended use, offer a power management function or a similar function. When equipment is not providing a main function, and other energy-using product(s) are not dependent on its functions, the power management function shall switch equipment after the shortest possible period of time appropriate for the intended use of the equipment, automatically into a condition having networked standby.		N/A
	In a condition providing networked standby, the power management function may switch equipment automatically into standby mode or off mode or another condition which does not exceed the applicable power consumption requirements for standby and/or off mode.		N/A
	The power management function, or a similar function, shall be available for all network ports of the networked equipment.		N/A
	The power management function, or a similar function, shall be activated, unless all network ports are deactivated. In that latter case the power management function, or a similar function, shall be activated if any of the network ports is activated.		N/A
	The default period of time after which the power management function, or a similar function, switches the equipment automatically into a condition providing networked standby shall not exceed 20 minutes.		N/A
3(c)	Networked equipment that has one or more standby modes shall comply with the requirements for these standby mode(s) when all network ports are deactivated.		N/A
3(d)	Networked equipment other than HiNA equipment shall comply with the provisions under 2(d) when all network ports are deactivated.		N/A
3(e)	Power consumption in a condition providing networked standby:		--
	The power consumption of HiNA equipment or equipment with HiNA functionality in a condition providing networked standby into which the equipment is switched by the power management function, or a similar function shall not exceed 12,00 W.		N/A
	The power consumption of other networked equipment in a condition providing networked standby into which the equipment is switched by the power management function, or a similar function, shall not exceed 6,00 W.		N/A

COMMISSION REGULATION (EC) No 1275/2008 & (EU) No 801/2013			
ANNEX II Ecodesign requirements			
Cl.	Requirement-Test	Result-Remark	Verdict
4(a)	Networked equipment that has one or more standby mode(s) shall comply with the requirements for these standby mode(s) when all wired network ports are disconnected and when all wireless network ports are deactivated.		N/A
4(b)	Networked equipment other than HiNA equipment shall comply with the provisions under 2(d) when all wired network ports are disconnected and when all wireless network ports are deactivated.		N/A
4(c)	Power consumption in a condition providing “networked standby”:		--
	The power consumption of HiNA equipment or equipment with HiNA functionality, in a condition providing networked standby into which the equipment is switched by the power management function, or a similar function, shall not exceed 8,00 W.		N/A
	The power consumption of other networked equipment in a condition providing networked standby into which the equipment is switched by the power management function, or a similar function, shall not exceed 3,00 W.		N/A
5	The power consumption of networked equipment other than HiNA equipment or other than equipment with HiNA functionality, in a condition providing networked standby into which the equipment is switched by the power management function, or a similar function, shall not exceed 2,00 W.		N/A
6	For coffee machines		N/A
	The delay time after which the product switches automatically into the modes and conditions referred to in Annex II, point 2, paragraph (d) shall be as follows:		N/A
	— for domestic drip filter coffee machines storing the coffee in an insulated jug, a maximum of five minutes after completion of the last brewing cycle or 30 minutes after completion of a descaling or self-cleaning process,		N/A
	— for domestic drip filter coffee machines storing the coffee in a non-insulated jug, a maximum of 40 minutes after completion of the last brewing cycle, or 30 minutes after completion of a descaling or self-cleaning process,		N/A

COMMISSION REGULATION (EC) No 1275/2008 & (EU) No 801/2013			
ANNEX II Ecodesign requirements			
Cl.	Requirement-Test	Result-Remark	Verdict
	— for domestic coffee machines other than drip filter coffee machines, a maximum of 30 minutes after completion of the last brewing cycle, or a maximum of 30 minutes after activation of the heating element, or a maximum of 60 minutes after activation of the cup preheating function, or a maximum of 30 minutes after completion of a descaling or self-cleaning process, unless an alarm has been triggered requiring users' intervention to prevent possible damage or accident.		N/A
	Until the above date the ecodesign requirements set out in Annex II.2.d shall not apply.		N/A

Table 1	Test parameters for measurements
The measurement method used.....:	EN 50564:2011
Test ambient temperature (°C).....:	23,0 °C / 23,0 °C
Test voltage in V and frequency in Hz.....:	230 V; 50 Hz
Total harmonic distortion (THD) of the electricity supply system.....:	1,221 %
Power consumption was determined by.....:	Average reading method
Description of how the appliance mode was selected or programmed.....:	Off mode
Sequence of events to reach the mode where the equipment automatically changes modes.....:	—
Other notes regarding the operation of the equipment.....:	—

Set-up and circuits used for electrical testing:

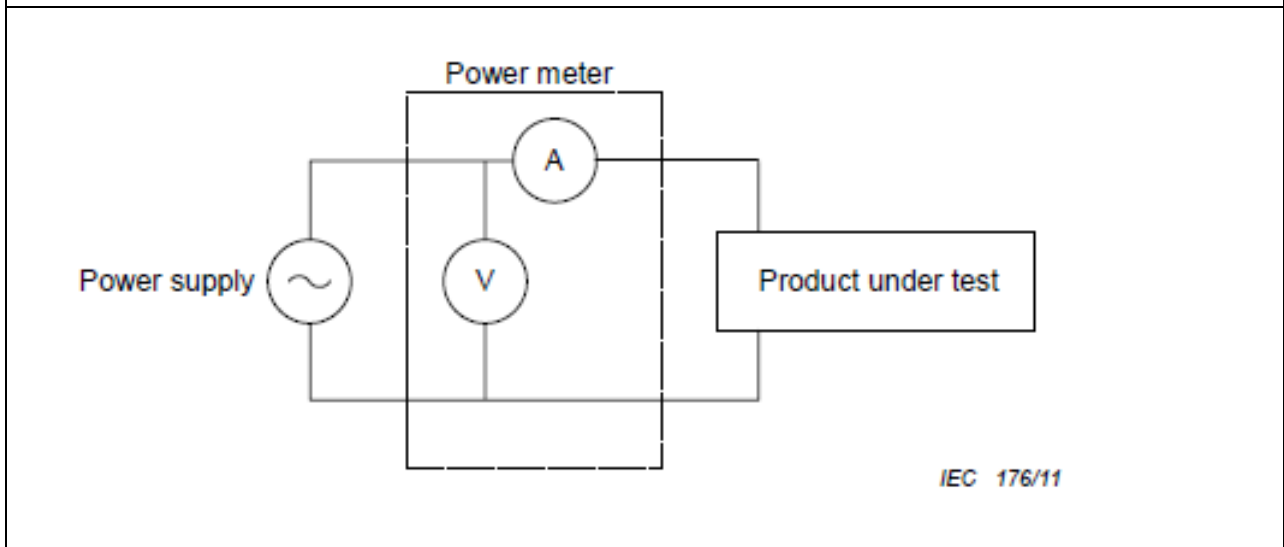

Table 2	Test result for equipment other than networked equipment or network equipment without network connection	P	
Operating mode(s)	Measured (W)	Limit (W)	
		Stage 1	Stage 2
Off-mode condition.....:	0	1	0,5
Any condition which does not exceed the applicable power consumption requirements for off mode when the equipment is connected to the mains power source.....:	—	1	0,5
Power consumption in 'standby mode(s)' in			
Any condition providing only a reactivation function, or providing only a reactivation function and a mere indication of enabled reactivation function.....:	—	1	0,5

Operating mode(s)	Measured (W)	Limit (W)	
		Stage 1	Stage 2
Any condition providing only information or status display, or providing only a combination of reactivation function and information or status display.....:	—	2	1
Any condition which does not exceed the applicable power consumption requirements for standby mode when the equipment is connected to the mains power source.....:	—		

Table 3	Test result for networked equipment with network connection			N/A
Power consumption in networked standby mode(s)	Measured (W)	Limit (W)		
		Stage 3	Stage 4	Stage 5
Networked standby (HiNA equipment or equipment with HiNA functionality)	—	12	8	8
Networked standby (other networked equipment)	—	6	3	2
Power management				
The default period of time after which the power management function, or a similar function, switches the equipment automatically into a condition providing networked standby (any of the network ports is activated).	Measured (minutes)		Limit (minutes)	
	—		20	

Result:	<input checked="" type="checkbox"/> Non-network equipment: the EUT complies with the ecodesign requirements Stage 2 of Annex II of COMMISSION REGULATION (EC) No 1275/2008 & (EU) No 801/2013. <input type="checkbox"/> Network equipment: The EUT complies with the ecodesign requirements <input type="checkbox"/> Stage 3 , <input type="checkbox"/> Stage 4 , <input type="checkbox"/> Stage 5 of Annex II of COMMISSION REGULATION (EC) No 1275/2008 & (EU) No 801/2013.
---------	--

Table 4	Test instruments			
Name	Brand	Model	Last cal. date	Next cal. date
Digital Power Analyzer	Yokogawa	WT310E	2018-05-15	2018-09-15

Circuit documents:

Details of: Model RC03-y

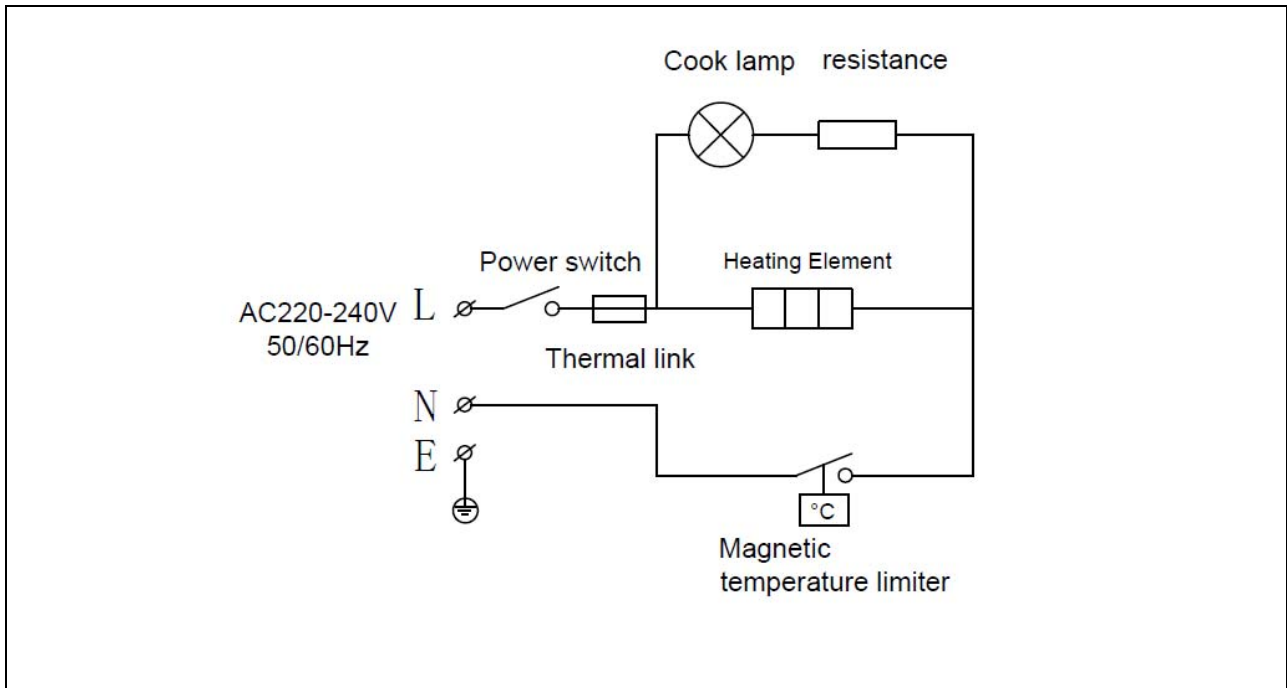

Details of: For the models z = 1

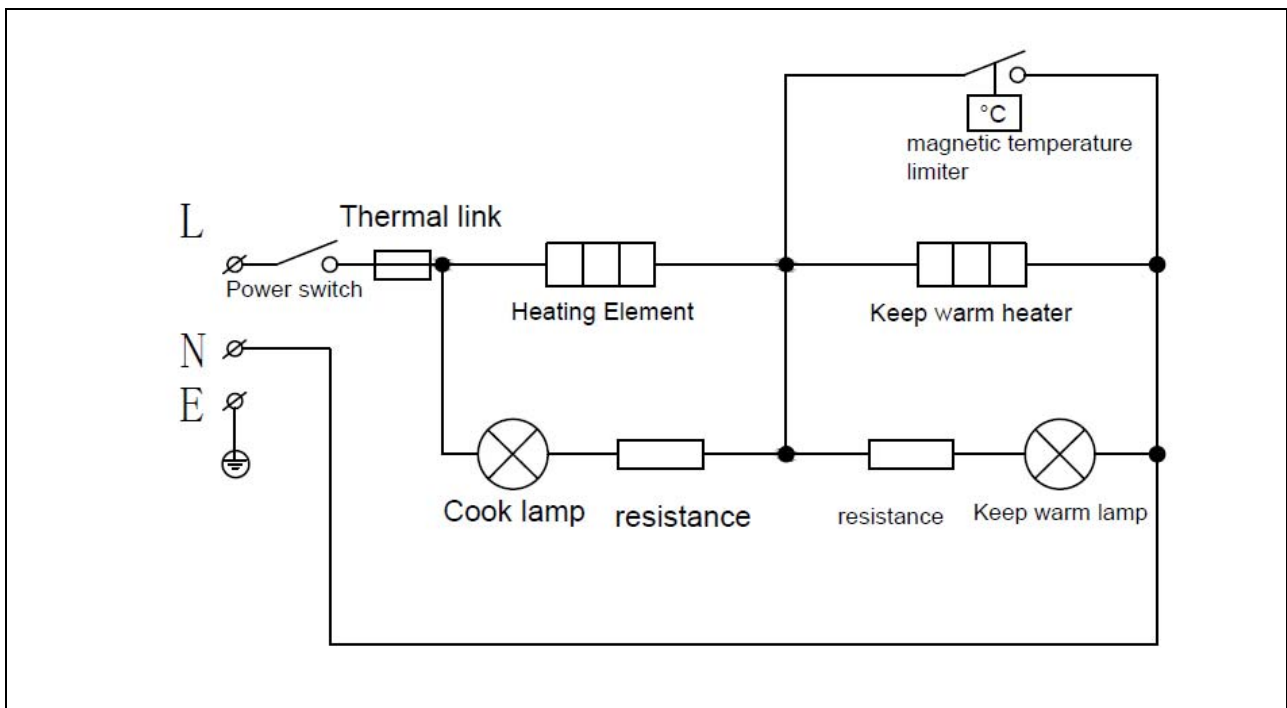

Details of: For the models z = 2

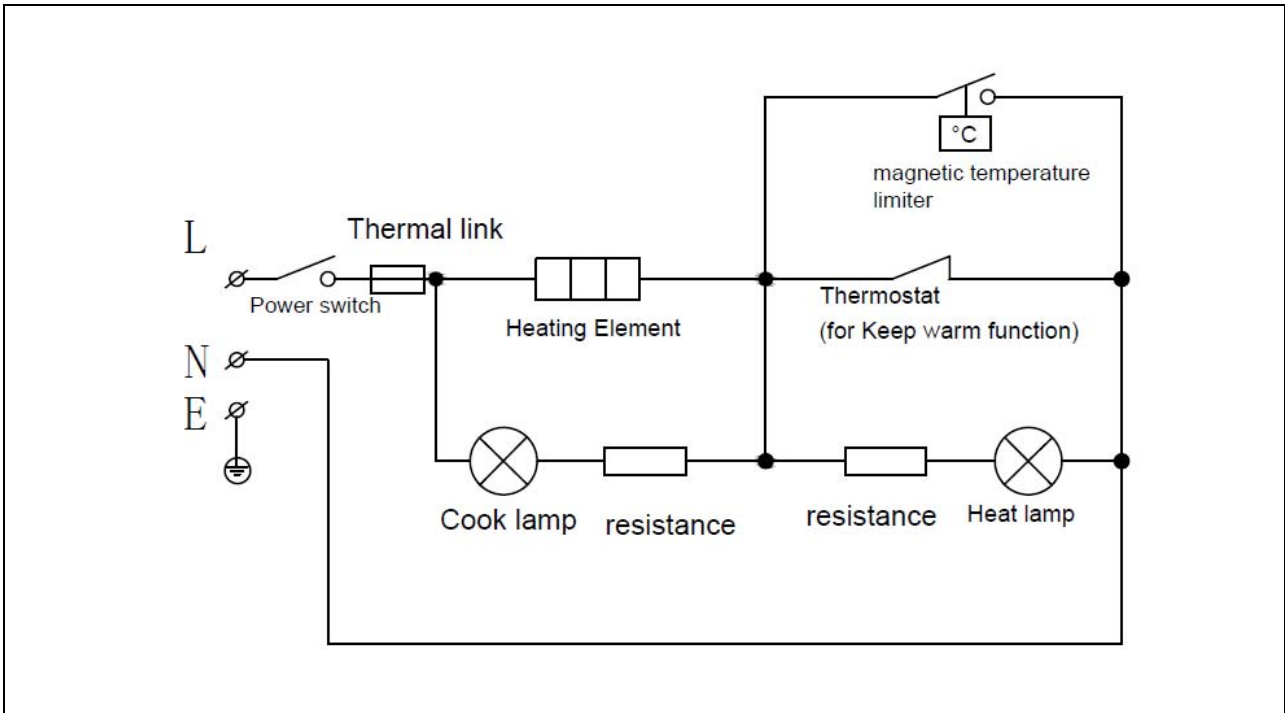

Details of: For the models z = 3

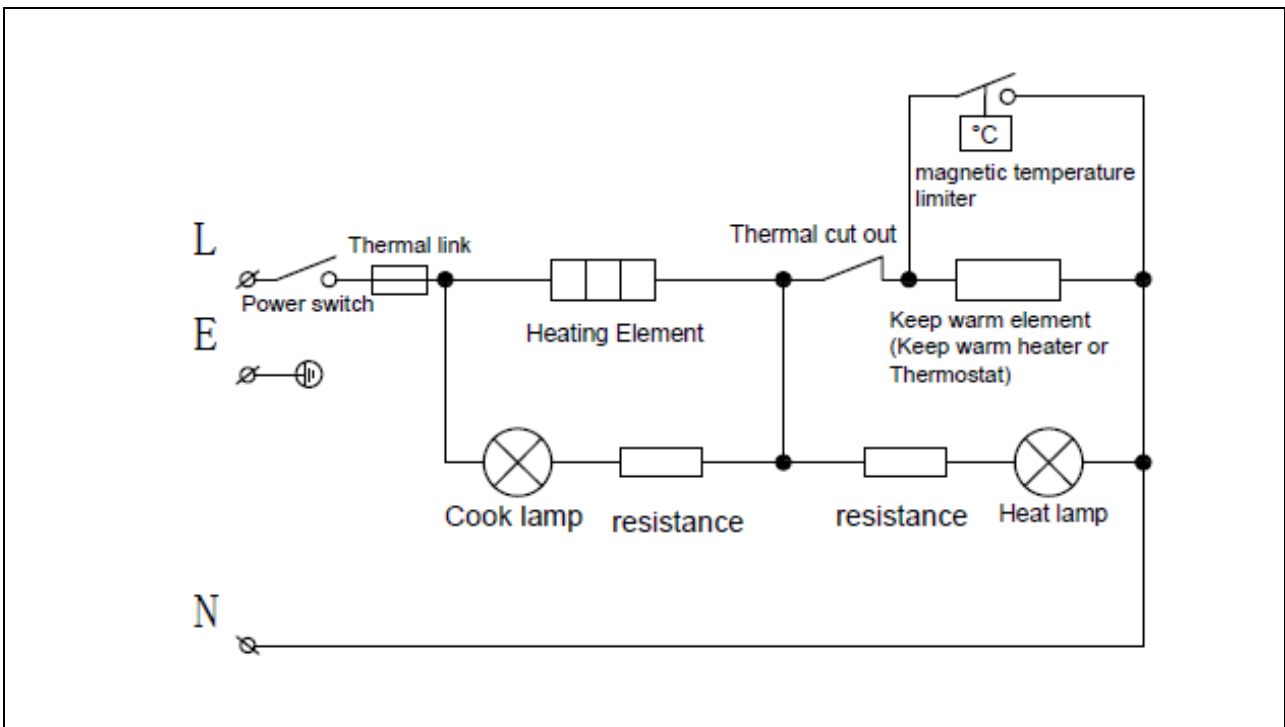

Photo documents:

Products General	
<p>RC120A-AY3</p> 	<p>DRC28S-xPB1</p> 
<p>RC18A-IX3</p> 	<p>SRC28C-qVX3</p> 

--- End of Report ---