

Test Verification of Conformity

On the basis of the referenced test report(s), the sample(s) of the below product has been found to comply with the relevant harmonized standard(s) to the directive(s) listed on this verification at the time the tests were carried out. The manufacturer may indicate compliance to only the said directives by signing a DoC himself and may affix the CE marking to products identical to the tested sample(s) if the product complies with all CE marking directives that has the product in their scope. In addition, the manufacturer shall file and keep the documentation according to the rules of the applicable directive(s) and shall consider changes of the standards as they may occur. Additional requirements, additional directives and local laws may be applicable.

| | |
|---|---|
| Applicant Name & Address | : Zhongshan Gonron Hardware Mfg Co., Ltd Xingwei Rd, Weimin Village, Fusha Town, Zhongshan City, Guangdong Province, China |
| Product(s) Tested | : Oven for household use, portable (Electric oven) |
| Ratings and principal characteristics | : 220-240 V~, 50/60Hz, Class I See the Annex to Test Verification of Conformity for all models |
| Model(s) | : See the Annex to Test Verification of Conformity |
| Brand name | : -- |
| Relevant Standard(s) / Specification(s) / Directive(s) | : EN 55014-1: 2006+A1: 2009/ Electromagnetic compatibility – Requirements for household appliances, electric tools and similar apparatus – Part 1: Emission EN 61000-3-2: 2006+ A1: 2009+ A2: 2009/ Electromagnetic compatibility (EMC) – Part 3-2: Limits – Limits for harmonic current emissions (equipment input current ≤ 16 A per phase) EN 61000-3-3: 2008/ Electromagnetic compatibility (EMC) – Part 3-3: Limits – Limitation of voltage changes, voltage fluctuations and flicker in public low-voltage supply systems, for equipment with rated current ≤ 16 A per phase and not subject to conditional connection EN 55014-2: 1997+A1: 2001+A2: 2008/ Electromagnetic compatibility – Requirements for household appliances, electric tools and similar apparatus – Part 2: Immunity – Product family standard EMC Directive 2004/108/EC |
| Verification Issuing Office Name & Address | : Same as Legal Entity |
| Verification/Report Number(s) | : GZ11090958-1/ GZ11090958-1 |

Note 1: This verification is part of the full test report(s) and should be read in conjunction with it.

This Verification is for the exclusive use of Intertek's Client and is provided pursuant to the agreement between Intertek and its Client. Intertek's responsibility and liability are limited to the terms and conditions of the agreement. Intertek assumes no liability to any party, other than to the Client in accordance with the agreement, for any loss, expense or damage occasioned by the use of this Verification. Only the Client is authorized to copy or distribute this Verification. Any use of the Intertek name or one of its marks for the sale or advertisement of the tested material, product or service must first be approved in writing by Intertek. The observations and test results referenced from this Verification are relevant only to the sample tested. This Verification by itself does not imply that the material, product, or service is or has ever been under an Intertek certification program.

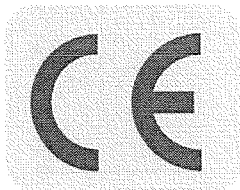

Signature

Name: Yannie Wang

Position: Manger

Date: 22 September 2011

Annex to Test Verification of Conformity

This is an Annex to Test Verification of Conformity with Verification/Report Number(s): GZ11090958-1/
GZ11090958-1. The issuing office is Intertek Testing Services Shenzhen Ltd. Guangzhou Branch
(Address: Block E, No. 7-2 Guang Dong Software Science Park, Caipin Road Guangzhou Science City,
GETDD Guangzhou).

| | |
|--|---|
| Ratings and principal characteristics | : 220-240 V~, 50/60Hz, Class I 1500W: GR28, GR28L, GR28R, GR28RC, GR28RL, GR28C, GR28CL, GR28RCL, GR33, GR33L, GR33R, GR33RC, GR33RL, GR33C, GR33CL, GR33RCL, GR35, GR35L, GR35R, GR35RC, GR35RL, GR35C, GR35CL, GR35RCL; 2000W: GR48, GR48L, GR48R, GR48RC, GR48RL, GR48C, GR48CL, GR48RCL; 3100W: GR28H3, GR28H3L, GR28RH3, GR28RH3L, GR28CH3, GR28CH3L, GR28RCH3, GR28RCH3L, GR33H3, GR33H3L, GR33RH3, GR33RH3L, GR33CH3, GR33CH3L, GR33RCH3, GR33RCH3L, GR35H3, GR35H3L, GR35RH3, GR35RH3L, GR35CH3, GR35CH3L, GR35RCH3, GR35RCH3L; 3200W: GR48H3, GR48H3L, GR48RH3, GR48RH3L, GR48CH3, GR48CH3L, GR48RCH3, GR48RCH3L |
| Model(s) | GR28, GR28L, GR28H3, GR28H3L, GR28R, GR28RC, GR28RL, GR28RH3, GR28RH3L, GR28C, GR28CL, GR28CH3, GR28CH3L, GR28RCL, GR28RCH3, GR28RCH3L; GR33, GR33L, GR33H3, GR33H3L, GR33R, GR33RC, GR33RL, GR33RH3, GR33RH3L, GR33C, GR33CL, GR33CH3, GR33CH3L, GR33RCL, GR33RCH3, GR33RCH3L; GR35, GR35L, GR35H3, GR35H3L, GR35R, GR35RC, GR35RL, GR35RH3, GR35RH3L, GR35C, GR35CL, GR35CH3, GR35CH3L, GR35RCL, GR35RCH3, GR35RCH3L; GR48, GR48L, GR48H3, GR48H3L, GR48R, GR48RC, GR48RL, GR48RH3, GR48RH3L, GR48C, GR48CL, GR48CH3, GR48CH3L, GR48RCL, GR48RCH3, GR48RCH3L |

Note 1: This annex is part of the Test Verification of Conformity and should be read in conjunction with it.

This Verification is for the exclusive use of Intertek's Client and is provided pursuant to the agreement between Intertek and its Client. Intertek's responsibility and liability are limited to the terms and conditions of the agreement. Intertek assumes no liability to any party, other than to the Client in accordance with the agreement, for any loss, expense or damage occasioned by the use of this Verification. Only the Client is authorized to copy or distribute this Verification. Any use of the Intertek name or one of its marks for the sale or advertisement of the tested material, product or service must first be approved in writing by Intertek. The observations and test results referenced from this Verification are relevant only to the sample tested. This Verification by itself does not imply that the material, product, or service is or has ever been under an Intertek certification program.

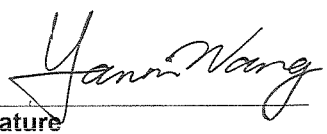

Signature

Name: Yannie Wang
Position: Manger

Date: 22 September 2011



TEST REPORT

Applicant Name & Address : Zhongshan Gonron Hardware Mfg Co., Ltd
Xingwei Rd, Weimin Village, Fusha Town, Zhongshan City, Guangdong Province, China
Manufacturing Site : Same as above

Sample Description
Product : Oven for household use, portable (Electric oven)
Model No. : Detail models see page 5
Electrical Rating : 220-240 V~, 50/60Hz, Class I
Detail Electrical Ratings see page 5

Date Received : 21 September 2011
Date Test Conducted : 21 September 2011-21 September 2011

Test standards : EN 55014-1: 2006+A1:2009
EN 61000-3-2: 2006+ A1:2009+ A2:2009
EN 61000-3-3: 2008
EN 55014-2: 1997+A1: 2001+A2: 2008

Test Result : Pass

Conclusion : The submitted samples complied with the above EMC standards.

Remark : None.

*****End of Page*****

Prepared and Checked By:

Approved By:

Darren

Darren Luo
Engineer
Intertek Guangzhou

Yannie Wang Signature

Yannie Wang
Manger
Intertek Guangzhou
22 September 2011 Date

This report is for the exclusive use of Intertek's Client and is provided pursuant to the agreement between Intertek and its Client. Intertek's responsibility and liability are limited to the terms and conditions of the agreement. Intertek assumes no liability to any party, other than to the Client in accordance with the agreement, for any loss, expense or damage occasioned by the use of this report. Only the Client is authorized to permit copying or distribution of this report and then only in its entirety. Any use of the Intertek name or one of its marks for the sale or advertisement of the tested material, product or service must first be approved in writing by Intertek. The observations and test results in this report are relevant only to the sample tested. This report by itself does not imply that the material, product, or service is or has ever been under an Intertek certification program. The test report only allows to be revised within three years from its original issued date unless further standard or the requirement was noticed.

CONTENT

| | |
|--|-----------|
| TEST REPORT | 1 |
| CONTENT | 2 |
| 1 TEST RESULTS SUMMARY | 3 |
| 2 EMC RESULTS CONCLUSION | 4 |
| 3 LABORATORY MEASUREMENTS | 6 |
| 4 EMI TEST | 7 |
| 4.1 EN 55014-1 CONTINUOUS CONDUCTED DISTURBANCE VOLTAGE TEST | 7 |
| 4.1.1 Used Test Equipment | 7 |
| 4.1.2 Block Diagram of Test Setup | 7 |
| 4.1.3 Test Setup and Procedure | 7 |
| 4.1.4 Test Data | 8 |
| 4.1.5 Emission Curve | 10 |
| 4.1.6 Measurement Uncertainty | 11 |
| 4.2 EN 55014-1 DISCONTINUOUS CONDUCTED DISTURBANCE VOLTAGE | 11 |
| 4.2.1 Used Test Equipment | 11 |
| 4.2.2 Block Diagram of Test Setup | 11 |
| 4.2.3 Test Setup and Procedure | 11 |
| 4.2.4 Test Data | 12 |
| 4.2.5 Measurement Uncertainty | 14 |
| 4.3 EN 55014-1 RADIATED DISTURBANCE POWER | 15 |
| 4.3.1 Used Test Equipment | 15 |
| 4.3.2 Block Diagram of Test Setup | 15 |
| 4.3.3 Test Setup and Procedure | 16 |
| 4.3.4 Test Data | 17 |
| 4.3.5 Test Curve | 18 |
| 4.3.6 Measurement Uncertainty | 18 |
| 4.4 EN 55014-1 RADIATED DISTURBANCE | 19 |
| 5 HARMONIC OF CURRENT | 19 |
| 5.1 USED TEST EQUIPMENT | 19 |
| 5.2 BLOCK DIAGRAM OF TEST SETUP | 19 |
| 5.3 TEST SETUP AND PROCEDURE | 19 |
| 5.4 TEST DATA | 20 |
| 5.5 MEASUREMENT UNCERTAINTY | 21 |
| 6 FLICKER | 22 |
| 6.1 USED TEST EQUIPMENT | 22 |
| 6.2 BLOCK DIAGRAM OF TEST SETUP | 22 |
| 6.3 TEST SETUP AND PROCEDURE | 22 |
| 6.3.1 Definition | 22 |
| 6.3.2 Test condition | 22 |
| 6.4 TEST DATA | 23 |
| 6.5 MEASUREMENT UNCERTAINTY | 23 |
| 7 APPENDIX I - PHOTOS OF TEST SETUP | 24 |
| 8 APPENDIX II - PHOTOS OF EUT | 26 |

1

TEST RESULTS SUMMARY

| Test Item | Standard | Result |
|---|--|---------------|
| Continuous conducted disturbance voltage | EN 55014-1: 2006+A1:2009 | Pass |
| Discontinuous conducted disturbance voltage | EN 55014-1: 2006+A1:2009 | Pass |
| Radiated disturbance power | EN 55014-1: 2006+A1:2009 | Pass |
| Radiated disturbance | EN 55014-1: 2006+A1:2009 Reference: CISPR 16-2-3: 2006 | N/A |
| Harmonic of current | EN 61000-3-2: 2006+ A1:2009+ A2:2009 | Pass |
| Flicker | EN 61000-3-3: 2008 | Pass |
| ESD immunity | EN 55014-2: 1997+A1: 2001+A2: 2008 Reference: EN 61000-4-2:1995+A1:1998+A2:2001 | N/A |
| Inject current immunity | EN 55014-2: 1997+A1: 2001+A2: 2008 Reference: EN 61000-4-6:2007 | N/A |
| Surge immunity | EN 55014-2: 1997+A1: 2001+A2: 2008 Reference: EN 61000-4-5:2006 | N/A |
| EFT immunity | EN 55014-2: 1997+A1: 2001+A2: 2008 Reference: EN 61000-4-4:2004 | N/A |
| Radiated EM field immunity | EN 55014-2: 1997+A1: 2001+A2: 2008 Reference: EN 61000-4-3:2006+A1:2008 | N/A |
| Voltage dips and interruption immunity | EN 55014-2: 1997+A1: 2001+A2: 2008 Reference: EN 61000-4-11:2004 | N/A |

Remark: 1. The symbol “N/A” in above table means Not Applicable.

2. When determining the test results, measurement uncertainty of tests has been considered.

2

EMC Results Conclusion
(with Justification)

RE: EMC Testing Pursuant to EMC Directive 2004/108/EC Performed on Oven for household use, portable (Electric oven),
 Model: GR28, GR28L, GR28H3, GR28H3L, GR28R, GR28RC, GR28RL, GR28RH3, GR28RH3L, GR28C, GR28CL, GR28CH3, GR28CH3L, GR28RCL, GR28RCH3, GR28RCH3L, GR33, GR33L, GR33H3, GR33H3L, GR33R, GR33RC, GR33RL, GR33RH3, GR33RH3L, GR33C, GR33CL, GR33CH3, GR33CH3L, GR33RCL, GR33RCH3, GR33RCH3L; GR35, GR35L, GR35H3, GR35H3L, GR35R, GR35RC, GR35RL, GR35RH3, GR35RH3L, GR35C, GR35CL, GR35CH3, GR35CH3L, GR35RCL, GR35RCH3, GR35RCH3L, GR48, GR48L, GR48H3, GR48H3L, GR48R, GR48RC, GR48RL, GR48RH3, GR48RH3L, GR48C, GR48CL, GR48CH3, GR48CH3L, GR48RCL, GR48RCH3, GR48RCH3L.

We tested the Oven for household use, portable (Electric oven), Models: GR48RCH3L, GR35RCH3L and GR28RCH3L, to determine if it was in compliance with the relevant EN standards as marked on the Test Results Summary. We found that the unit met the requirements of EN 55014-1, EN 61000-3-2 and EN 61000-3-3 standards when tested as received. The worst case’s test data was presented in this test report.

All models have same the construction except for the figure, the function, the capacity and the rated power, detail differences see page 5 and as below:

| Model No. | | | | Function |
|------------|------------|------------|------------|--|
| 28 (Litre) | 33 (Litre) | 35 (Litre) | 48 (Litre) | |
| GR28 | GR33 | GR35 | GR48 | Heater |
| GR28L | GR33L | GR35L | GR48L | Heater + E14 lamp |
| GR28H3 | GR33H3 | GR35H3 | GR48H3 | Heater + Hotplate |
| GR28H3L | GR33H3L | GR35H3L | GR48H3L | Heater + Hotplate + E14 lamp |
| GR28R | GR33R | GR35R | GR48R | Heater + Swing motor |
| GR28RC | GR33RC | GR35RC | GR48RC | Heater + Swing motor + Fan motor |
| GR28RL | GR33RL | GR35RL | GR48RL | Heater + Swing motor + E14 lamp |
| GR28RH3 | GR33RH3 | GR35RH3 | GR48RH3 | Heater + Hotplate + Swing motor |
| GR28RH3L | GR33RH3L | GR35RH3L | GR48RH3L | Heater + Hotplate + Swing motor + E14 lamp |
| GR28C | GR33C | GR35C | GR48C | Heater + Fan motor |
| GR28CL | GR33CL | GR35CL | GR48CL | Heater + Fan motor + E14 lamp |
| GR28CH3 | GR33CH3 | GR35CH3 | GR48CH3 | Heater + Hotplate + Fan motor |
| GR28CH3L | GR33CH3L | GR35CH3L | GR48CH3L | Heater + Hotplate + Fan motor + E14 lamp |
| GR28RCL | GR33RCL | GR35RCL | GR48RCL | Heater + Swing motor + Fan motor + E14 lamp |
| GR28RCH3 | GR33RCH3 | GR35RCH3 | GR48RCH3 | Heater + Hotplate + Swing motor + Fan motor |
| GR28RCH3L | GR33RCH3L | GR35RCH3L | GR48RCH3L | Heater + Hotplate + Swing motor + Fan motor + E14 lamp |

Base on above difference, Full EMC tests are performed on model GR48RCH3L, Click tests are performed on models GR28RCH3L and GR35RCH3L. Test data of model GR48RCH3L, GR28RCH3L and GR35RCH3L can represent the test data of other models.

Model No.:

GR28, GR28L, GR28H3, GR28H3L, GR28R, GR28RC, GR28RL, GR28RH3, GR28RH3L, GR28C, GR28CL, GR28CH3, GR28CH3L, GR28RCL, GR28RCH3, GR28RCH3L;

GR33, GR33L, GR33H3, GR33H3L, GR33R, GR33RC, GR33RL, GR33RH3, GR33RH3L, GR33C, GR33CL, GR33CH3, GR33CH3L, GR33RCL, GR33RCH3, GR33RCH3L;

GR35, GR35L, GR35H3, GR35H3L, GR35R, GR35RC, GR35RL, GR35RH3, GR35RH3L, GR35C, GR35CL, GR35CH3, GR35CH3L, GR35RCL, GR35RCH3, GR35RCH3L;

GR48, GR48L, GR48H3, GR48H3L, GR48R, GR48RC, GR48RL, GR48RH3, GR48RH3L, GR48C, GR48CL, GR48CH3, GR48CH3L, GR48RCL, GR48RCH3, GR48RCH3L

Electrical Rating:

220-240 V~, 50/60Hz, Class I

1500W: GR28, GR28L, GR28R, GR28RC, GR28RL, GR28C, GR28CL, GR28RCL, GR33, GR33L, GR33R, GR33RC, GR33RL, GR33C, GR33CL, GR33RCL, GR35, GR35L, GR35R, GR35RC, GR35RL, GR35C, GR35CL, GR35RCL;

2000W: GR48, GR48L, GR48R, GR48RC, GR48RL, GR48C, GR48CL, GR48RCL;

3100W: GR28H3, GR28H3L, GR28RH3, GR28RH3L, GR28CH3, GR28CH3L, GR28RCH3, GR28RCH3L, GR33H3, GR33H3L, GR33RH3, GR33RH3L, GR33CH3, GR33CH3L, GR33RCH3, GR33RCH3L, GR35H3, GR35H3L, GR35RH3, GR35RH3L, GR35CH3, GR35CH3L, GR35RCH3, GR35RCH3L;

3200W: GR48H3, GR48H3L, GR48RH3, GR48RH3L, GR48CH3, GR48CH3L, GR48RCH3, GR48RCH3L

The production units are required to conform to the initial sample as received when the units are placed on the market.

Standards against which no testing has been conducted of the captioned model and the engineering judgement is stated as follows:

EN55014-2: This product contains no electronic control circuitry. It is classified to Category I of the standard and is therefore deemed to fulfil the relevant immunity requirements without testing.

3

LABORATORY MEASUREMENTS**Configuration Information**

| | |
|------------------------------------|---|
| Equipment Under Test (EUT): | Oven for household use, portable (Electric oven) |
| Model: | GR48RCH3L, GR35RCH3L, GR28RCH3L |
| Serial No. | Not Labeled |
| Support Equipment: | N/A |
| Rated Voltage: | 220-240 V~, 50/60Hz, Class I |
| Condition of Environment: | Temperature : 22~28°C Relative Humidity: 35~60% Atmosphere Pressure 86~106kPa |

Notes:

1. The EMI measurements had been made in the operating mode produced the largest emission in the frequency band being investigated consistent with normal applications.
An attempt had been made to maximize the emission by varying the configuration of the EUT.
2. The EMS measurements had been made in the frequency bands being investigated, with the EUT in the most susceptible operating mode consistent with normal applications. The configuration of the test sample had been varied to achieve maximum susceptibility.

4 EMI TEST

4.1 EN 55014-1 Continuous Conducted Disturbance Voltage Test

Test Result: Pass

4.1.1 Used Test Equipment

| Equipment No. | Equipment | Model | Manufacturer |
|---------------|-----------------|----------|--------------|
| EM080-05 | EMI receiver | ESCI | R&S |
| EM006-05 | LISN | ENV216 | R&S |
| EM004-04 | EMC shield Room | 8m×3m×3m | Zhongyu |

4.1.2 Block Diagram of Test Setup

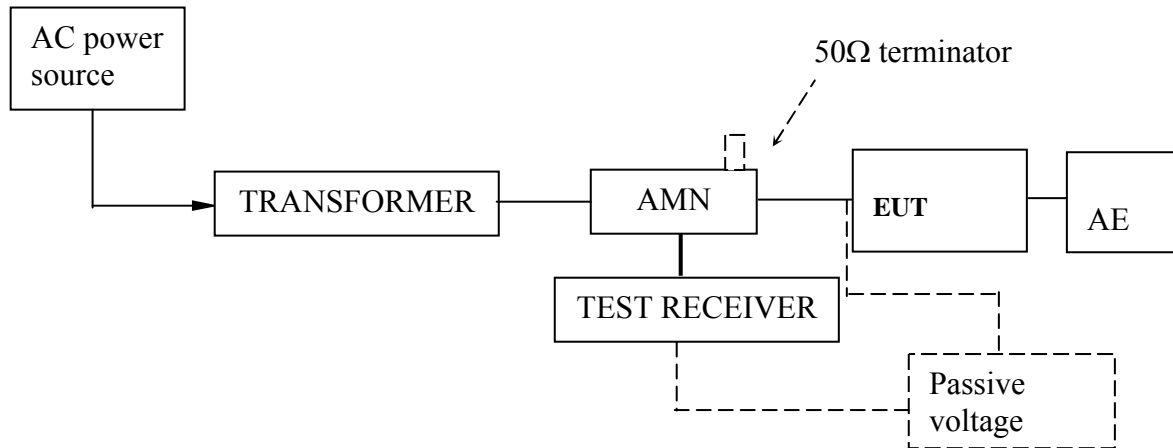

4.1.3 Test Setup and Procedure

The EUT was set to achieve the maximum emission level. The mains terminal disturbance voltage was measured with the EUT in a shielded room. The EUT was connected to AC power source through an Artificial Mains Network which provides a 50Ω linear impedance. Artificial hand is used if appropriate (for handheld apparatus). The load/control terminal disturbance voltage was measured with passive voltage probe if appropriate.

The table-top EUT was placed on a 0.4m high non-metallic table above earthed ground plane (Ground Reference Plane). And for floor standing EUT, was placed on a 0.1m high non-metallic supported on GRP. The EUT keeps a distance of at least 0.8m from any other of the metallic surface. The Artificial Mains Network is situated at a distance of 0.8m from the EUT.

During the test, mains lead of EUT excess 0.8m was folded back and forth parallel to the lead so as to form a horizontal bundle with a length between 0.3m and 0.4m.

The bandwidth of test receiver was set at 9 kHz. The frequency range from 150 kHz to 30MHz was checked.

When measurements of disturbance are being made, the appliance shall be operated under the conditions defined in clause 7.

4.1.4 Test Data

At main terminal: Pass

Tested Wire: Live

Operation Mode: EUT on

| Frequency [MHz] | Quasi-Peak | | Average | |
|--------------------|-------------------------------|-----------------------------|-------------------------------|-----------------------------|
| | Disturbance level [dB(μV)] | Permitted limit [dB(μV)] | Disturbance level [dB(μV)] | Permitted limit [dB(μV)] |
| 0.160 | <55 | 65.5 | <48 | 58.3 |
| 0.240 | <52 | 62.1 | <43 | 53.9 |
| 0.550 | <46 | 56.0 | <36 | 46.0 |
| 1.000 | <46 | 56.0 | <36 | 46.0 |
| 1.400 | <46 | 56.0 | <36 | 46.0 |
| 2.000 | <46 | 56.0 | <36 | 46.0 |
| 3.500 | <46 | 56.0 | <36 | 46.0 |
| 6.000 | <50 | 60.0 | <40 | 50.0 |
| 10.000 | <50 | 60.0 | <40 | 50.0 |
| 22.000 | <50 | 60.0 | <40 | 50.0 |
| 30.000 | <50 | 60.0 | <40 | 50.0 |

Tested Wire: Neutral

Operation Mode: EUT on

| Frequency [MHz] | Quasi-Peak | | Average | |
|--------------------|-------------------------------|-----------------------------|-------------------------------|-----------------------------|
| | Disturbance level [dB(μV)] | Permitted limit [dB(μV)] | Disturbance level [dB(μV)] | Permitted limit [dB(μV)] |
| 0.160 | <55 | 65.5 | <48 | 58.3 |
| 0.240 | <52 | 62.1 | <43 | 53.9 |
| 0.550 | <46 | 56.0 | <36 | 46.0 |
| 1.000 | <46 | 56.0 | <36 | 46.0 |
| 1.400 | <46 | 56.0 | <36 | 46.0 |
| 2.000 | <46 | 56.0 | <36 | 46.0 |
| 3.500 | <46 | 56.0 | <36 | 46.0 |
| 6.000 | <50 | 60.0 | <40 | 50.0 |
| 10.000 | <50 | 60.0 | <40 | 50.0 |
| 22.000 | <50 | 60.0 | <40 | 50.0 |
| 30.000 | <50 | 60.0 | <40 | 50.0 |

At load/control terminal: Not Applicable

| Frequency [MHz] | Quasi-Peak | | Average | |
|--------------------|-------------------------------|-----------------------------|-------------------------------|-----------------------------|
| | Disturbance level [dB(μV)] | Permitted limit [dB(μV)] | Disturbance level [dB(μV)] | Permitted limit [dB(μV)] |
| -- | -- | -- | -- | -- |
| -- | -- | -- | -- | -- |
| -- | -- | -- | -- | -- |
| -- | -- | -- | -- | -- |
| -- | -- | -- | -- | -- |

4.1.5 Emission Curve At mains terminal: Tested Wire: Live

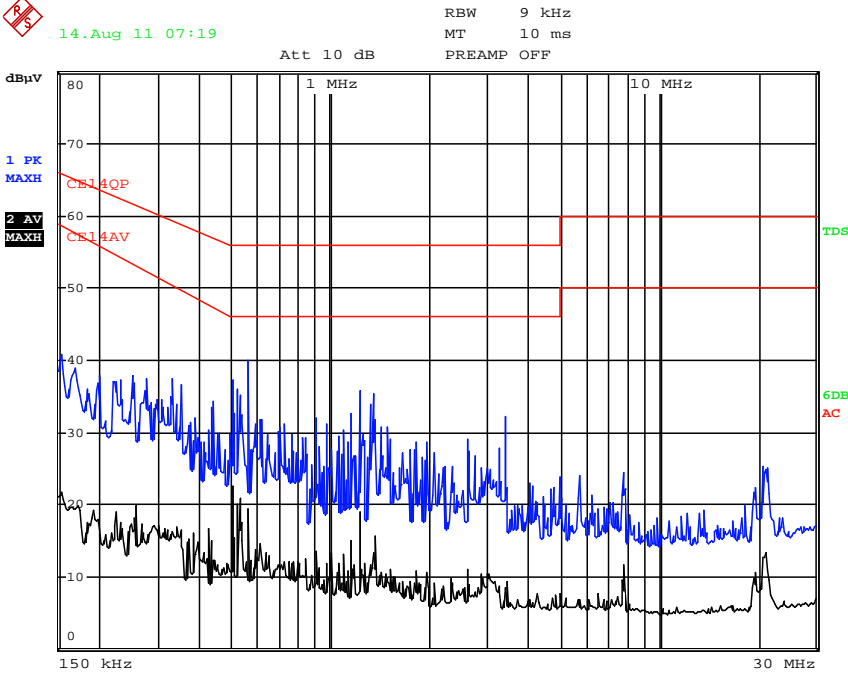

Tested Wire: Neutral

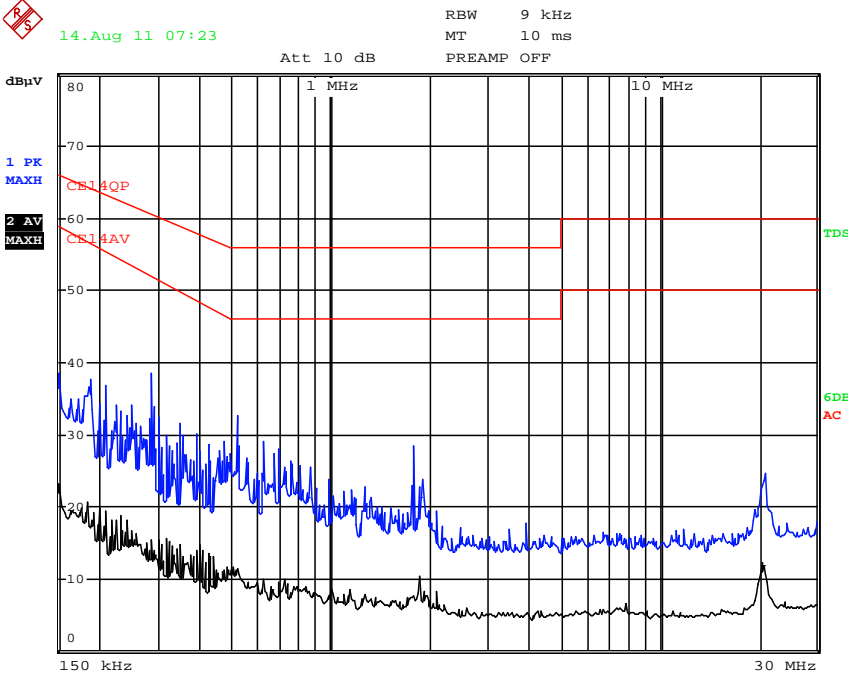

At load/control terminal:

Not Applicable.

4.1.6 Measurement Uncertainty

The measurement uncertainty describes the overall uncertainty of the given measured value during the operation of the EUT.

Measurement uncertainty is calculated in accordance with CISPR 16-4-2:2003.

Measurement uncertainty of mains terminal disturbance voltage in CISPR band B: 2.5 dB.

The measurement uncertainty is given with a confidence of 95%, k=2.

4.2 EN 55014-1 Discontinuous Conducted Disturbance Voltage

Test Result: Pass

4.2.1 Used Test Equipment

| Equipment No. | Equipment | Model | Manufacturer |
|---------------|-----------------|----------|--------------|
| EM008-01 | Click Tester | DIA1512D | SCHAFFNER |
| EM006-04 | LISN | ESH2-Z5 | R&S |
| EM004-03 | EMC shield Room | 8m×4m×3m | Zhongyu |

4.2.2 Block Diagram of Test Setup

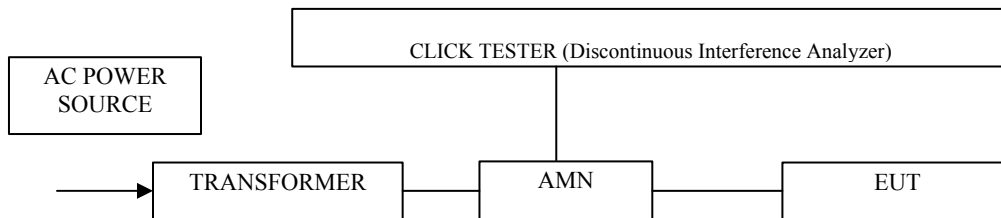

4.2.3 Test Setup and Procedure

The EUT was placed on a 0.8m high non-metallic table in shielded room, the wall of shielded room used as Ground Reference Plane (GRP), and keeps a distance of at least 0.8m from any of the other metallic surface.

The EUT was connected to an artificial mains network and at a distance of 0.8m from it, the excess lead of EUT was bundled with a length of 0.3m to 0.4m parallel to the main lead.

The number of counted clicks above the permitted limit for continuous interference and their duration, spacing and rate were measured during the observation time. When relevant, a permitted(relaxed) limit for clicks were calculated and a second measurement was performed. Determination of compliance with the permitted limit according to the upper quartile method was applied. The frequency 150kHz, 500 kHz, 1.4 MHz and 30 MHz was checked.

When measurements of disturbance are being made, the appliance shall be operated under the conditions defined in clause 7.

4.2.4 Test Data

Model: GR48RCH3L

| | | | | |
|---|------|------|------|-------|
| Frequency (MHz) | 0.15 | 0.50 | 1.40 | 30.00 |
| Permitted limit for continuous interference (dB μ V) | 66 | 56 | 56 | 60 |
| Short Clicks [T<10ms] | 14 | 11 | 1 | 0 |
| Mid. Clicks [10ms<T<20ms] | 0 | 0 | 0 | 0 |
| Long Clicks [T>20ms] | 0 | 0 | 0 | 0 |
| Total clicks (number) | 14 | 11 | 1 | 0 |
| Switching operation (number) | -- | | | |
| Factor | -- | | | |
| Observation time (min.) | 120 | | | |
| Click rate, N | 0.12 | 0.09 | 0.09 | 0.09 |
| Value to be added (dB) | -- | -- | -- | -- |
| Counted clicks allowed to exceed the permitted limit (number) | -- | -- | -- | -- |
| Permitted limit for clicks (dB μ V) | -- | -- | -- | -- |
| Counted clicks exceeding the limit (number) | -- | -- | -- | -- |
| Complies with the limit (Pass/Fail) | Pass | Pass | Pass | Pass |

Model: GR35RCH3L

| | | | | |
|---|------|------|------|-------|
| Frequency (MHz) | 0.15 | 0.50 | 1.40 | 30.00 |
| Permitted limit for continuous interference (dB μ V) | 66 | 56 | 56 | 60 |
| Short Clicks [T<10ms] | 1 | 1 | 0 | 0 |
| Mid. Clicks [10ms<T<20ms] | 0 | 0 | 0 | 0 |
| Long Clicks [T>20ms] | 0 | 0 | 0 | 0 |
| Total clicks (number) | 1 | 1 | 0 | 0 |
| Switching operation (number) | -- | | | |
| Factor | -- | | | |
| Observation time (min.) | 120 | | | |
| Click rate, N | 0.01 | 0.01 | 0.01 | 0.01 |
| Value to be added (dB) | -- | -- | -- | -- |
| Counted clicks allowed to exceed the permitted limit (number) | -- | -- | -- | -- |
| Permitted limit for clicks (dB μ V) | -- | -- | -- | -- |
| Counted clicks exceeding the limit (number) | -- | -- | -- | -- |
| Complies with the limit (Pass/Fail) | Pass | Pass | Pass | Pass |

Model: GR28RCH3L

| | | | | |
|---|------|------|------|-------|
| Frequency (MHz) | 0.15 | 0.50 | 1.40 | 30.00 |
| Permitted limit for continuous interference (dB μ V) | 66 | 56 | 56 | 60 |
| Short Clicks [T<10ms] | 4 | 3 | 1 | 0 |
| Mid. Clicks [10ms<T<20ms] | 0 | 0 | 0 | 0 |
| Long Clicks [T>20ms] | 0 | 0 | 0 | 0 |
| Total clicks (number) | 4 | 3 | 1 | 0 |
| Switching operation (number) | -- | | | |
| Factor | -- | | | |
| Observation time (min.) | 120 | | | |
| Click rate, N | 0.03 | 0.02 | 0.02 | 0.02 |
| Value to be added (dB) | -- | -- | -- | -- |
| Counted clicks allowed to exceed the permitted limit (number) | -- | -- | -- | -- |
| Permitted limit for clicks (dB μ V) | -- | -- | -- | -- |
| Counted clicks exceeding the limit (number) | -- | -- | -- | -- |
| Complies with the limit (Pass/Fail) | Pass | Pass | Pass | Pass |

4.2.5 Measurement Uncertainty

The measurement uncertainty for click test is under consideration according to CISPR 16-4-2:2003.

4.3 EN 55014-1 Radiated Disturbance Power

Test Result: Pass

4.3.1 Used Test Equipment

| Equip. No. | Equipment | Model | Manufacturer |
|------------|--------------------|----------|--------------|
| EM080-05 | EMI receiver | ESCI | R&S |
| EM081-04 | Absorb Power Clamp | MDS-21 | R&S |
| EM004-04 | EMC shield Room | 8m×3m×3m | Zhongyu |

4.3.2 Block Diagram of Test Setup

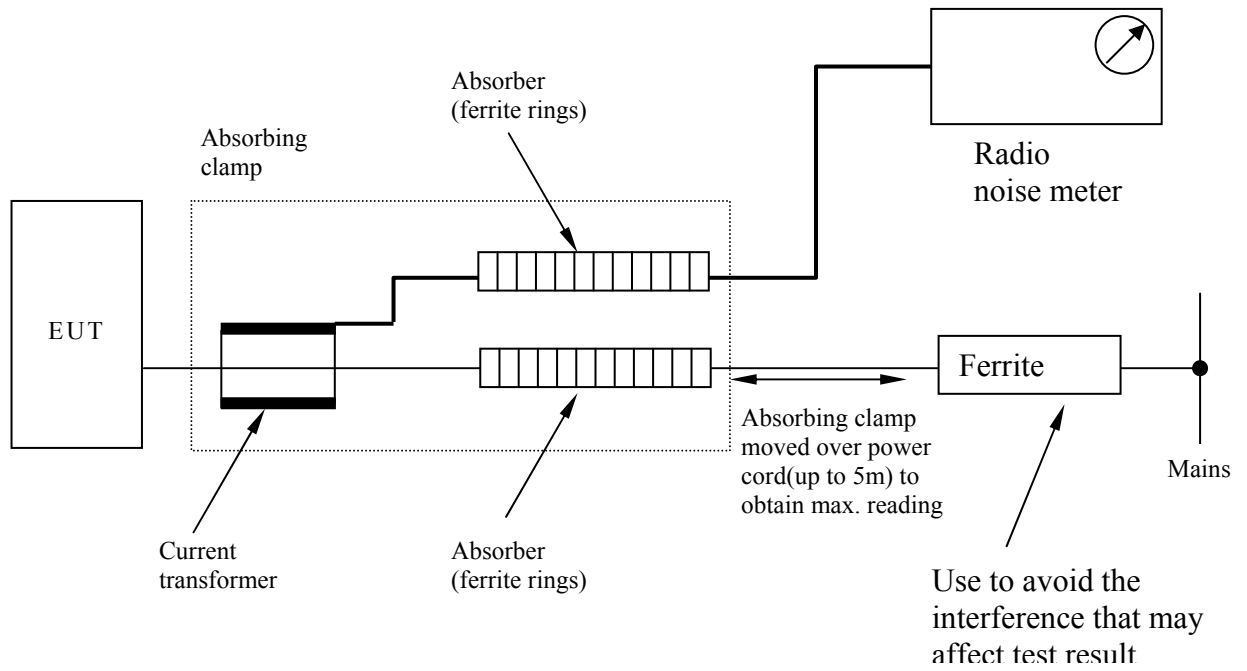

4.3.3 Test Setup and Procedure

The disturbance power was measured with the EUT in a shielded room. The height of the table shall be $0,1 \text{ m} \pm 0,025 \text{ m}$ for appliances primarily intended to be positioned on the floor in normal use, and $0,8 \text{ m} \pm 0,05 \text{ m}$ for other appliances. The EUT was placed on a non-metallic table at least 0.8m from other metallic surface and the mains lead of EUT was extended to about 6m long. The auxiliary lead longer than 0.25m but shorter than twice length of absorbing clamp was extend to twice length of clamp and those longer than twice length was extend to 6 meters.

The absorbing clamp was moved along the lead to obtain maximum disturbance. The EUT was set to achieve the maximum emission level, and for each point which appears a relevant high emission level, the absorbing clamp was moved around the lead to get the maximum disturbance value.

The bandwidth of test receiver was set at 120 kHz. The frequency range from 30MHz to 300MHz was checked.

When measurements of disturbance are being made, the appliance shall be operated under the conditions defined in clause 7.

4.3.4 Test Data

Tested Port: mains

Operation mode: EUT on

| Frequency [MHz] | Quasi-Peak | | Average | |
|--------------------|-------------------------------|-----------------------------|-------------------------------|-----------------------------|
| | Disturbance level [dB(pW)] | Permitted limit [dB(pW)] | Disturbance level [dB(pW)] | Permitted limit [dB(pW)] |
| 30.000 | <35 | 45.0 | <25 | 35.0 |
| 33.400 | <35 | 45.1 | <25 | 35.1 |
| 35.500 | <35 | 45.2 | <25 | 35.2 |
| 36.500 | <35 | 45.2 | <25 | 35.2 |
| 39.500 | <35 | 45.4 | <25 | 35.4 |
| 45.000 | <35 | 45.6 | <25 | 35.6 |
| 48.000 | <35 | 45.7 | <25 | 35.7 |
| 65.000 | <36 | 46.3 | <26 | 36.3 |
| 72.000 | <36 | 46.6 | <26 | 36.6 |
| 83.000 | <37 | 47.0 | <27 | 37.0 |
| 90.000 | <37 | 47.2 | <27 | 37.2 |
| 150.000 | <39 | 49.4 | <29 | 39.4 |
| 180.000 | <40 | 50.6 | <30 | 40.6 |
| 220.000 | <42 | 52.0 | <32 | 42.0 |
| 300.000 | <45 | 55.0 | <35 | 45.0 |

the measurement quasi-peak data of disturbance power is lower than applicable limit reduced by the margin (0 to 10dB) at frequency range 200 to 300 MHz and the maximum clock frequency is less than 30MHz

4.3.5 Test Curve

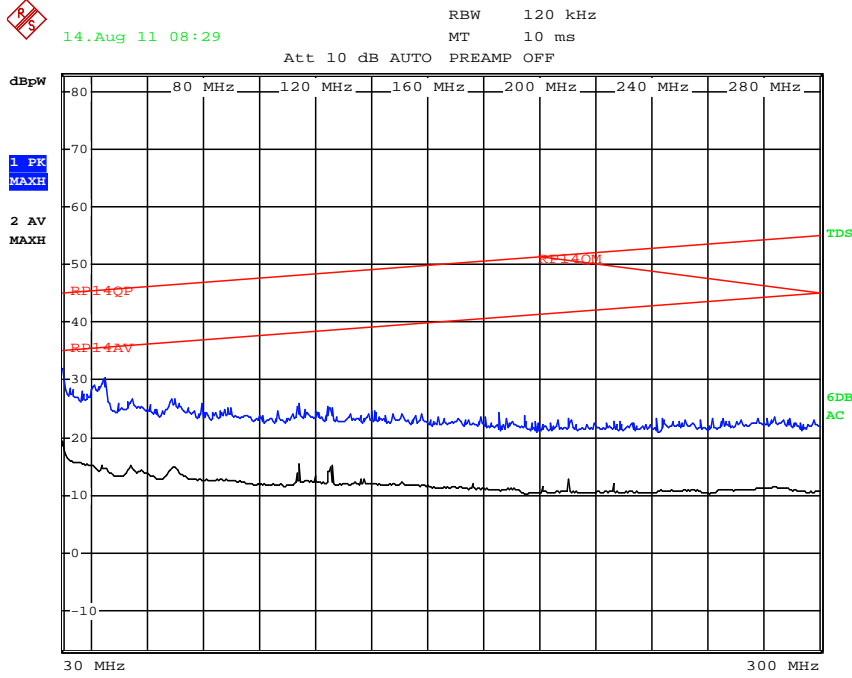

4.3.6 Measurement Uncertainty

The measurement uncertainty describes the overall uncertainty of the given measured value during the operation of the EUT.

Measurement uncertainty is calculated in accordance with CISPR 16-4-2:2003.

Measurement uncertainty of mains terminal disturbance power: 3.0dB

The measurement uncertainty is given with a confidence of 95%, k=2.

4.4 EN 55014-1 Radiated Disturbance

Test Result: Not Applicable

Remark:

Radiated disturbance shall not be conducted, if the measurement quasi-peak data of disturbance power is lower than applicable limit reduced by the margin (0 to 10dB) at frequency range 200 to 300 MHz and the maximum clock frequency is less than 30MHz,.

5 Harmonic of Current

Test Result: Pass

5.1 Used Test Equipment

| Equip. No. | Equipment | Model | Manufacturer |
|------------|--------------------------------|--------------------|-----------------------|
| EM001-02 | Harmonic & Flicker Test System | 5001IX-CTS-400-413 | California Instrument |

5.2 Block Diagram of Test Setup

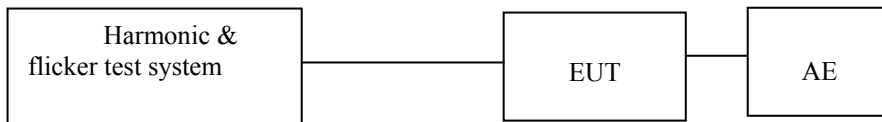

5.3 Test Setup and Procedure

Harmonics of the fundamental current were measured up to 40 order harmonics using a digital power meter with an analogue output and frequency analyser which was integrated in the harmonic & flicker test system. The measurements were carried out under steady conditions.

5.4 Test Data

Harmonics – Class-A per Ed. 3.0 (incl. inter-harmonics)

Current & voltage waveforms

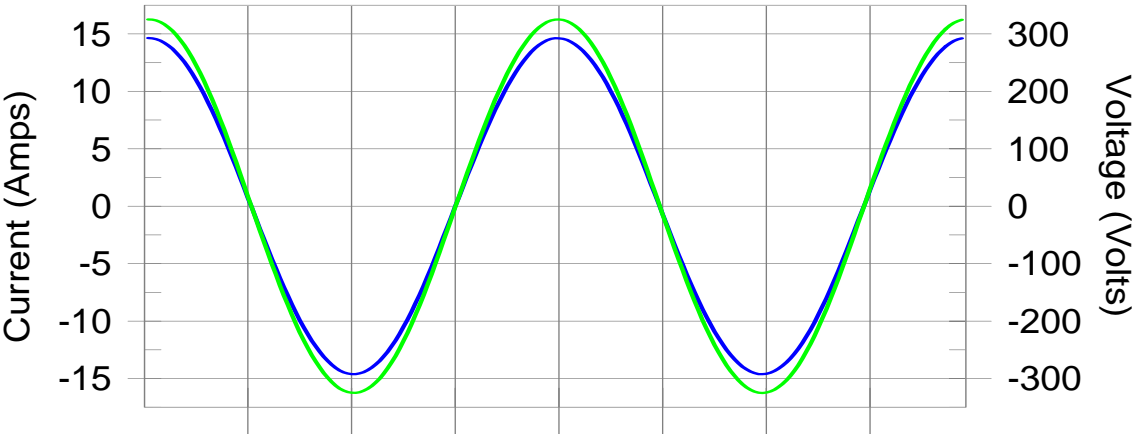

Harmonics and Class A limit line

European Limits

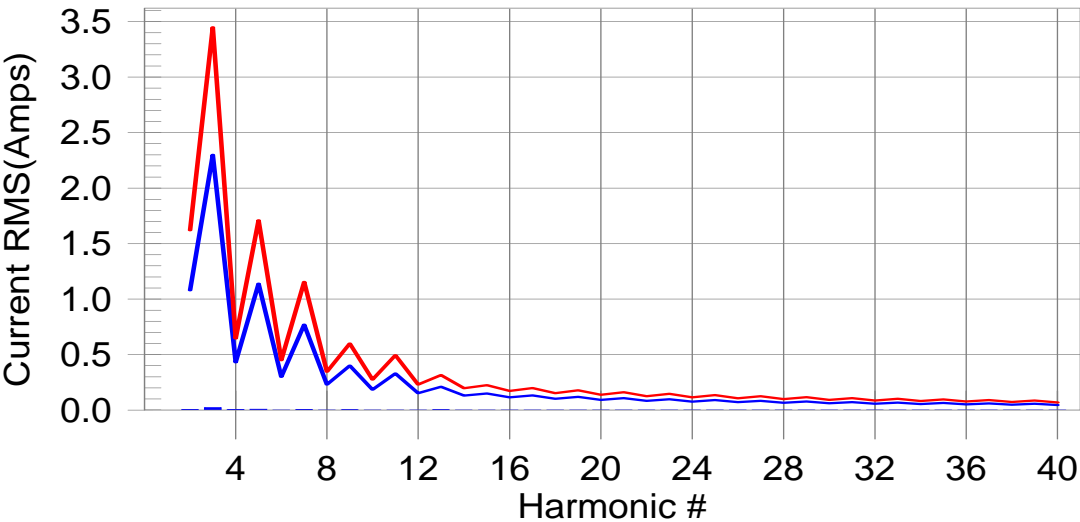

Test result: Pass **Worst harmonic was #3 with 0.86% of the limit.**

Current Test Result Summary (Run time)

Test Result: Pass Source qualification: Normal

THC(A): 0.02 I-THD(%): 0.21 POHC(A): 0.000 POHC Limit(A): 0.320

Highest parameter values during test:

| | | | |
|----------------|--------|----------------|--------|
| V_RMS (Volts): | 229.97 | Frequency(Hz): | 50.00 |
| I_Peak (Amps): | 14.651 | I_RMS (Amps): | 10.342 |
| I_Fund (Amps): | 10.340 | Crest Factor: | 1.417 |
| Power (Watts): | 2377.2 | Power Factor: | 1.000 |

| Harm# | Harms(avg) | 100%Limit | %of Limit | Harms(max) | 150%Limit | %of Limit | Status |
|-------|------------|-----------|-----------|------------|-----------|-----------|--------|
| 2 | 0.004 | 1.080 | 0.0 | 0.004 | 1.620 | 0.27 | Pass |
| 3 | 0.020 | 2.300 | 0.9 | 0.024 | 3.450 | 0.69 | Pass |
| 4 | 0.004 | 0.430 | 0.0 | 0.005 | 0.645 | 0.71 | Pass |
| 5 | 0.008 | 1.140 | 0.7 | 0.009 | 1.710 | 0.50 | Pass |
| 6 | 0.002 | 0.300 | 0.0 | 0.002 | 0.450 | 0.45 | Pass |
| 7 | 0.003 | 0.770 | 0.0 | 0.004 | 1.155 | 0.34 | Pass |
| 8 | 0.001 | 0.230 | 0.0 | 0.002 | 0.345 | 0.44 | Pass |
| 9 | 0.002 | 0.400 | 0.0 | 0.002 | 0.600 | 0.37 | Pass |
| 10 | 0.001 | 0.184 | 0.0 | 0.001 | 0.276 | 0.54 | Pass |
| 11 | 0.002 | 0.330 | 0.0 | 0.002 | 0.495 | 0.39 | Pass |
| 12 | 0.001 | 0.153 | 0.0 | 0.001 | 0.230 | 0.46 | Pass |
| 13 | 0.002 | 0.210 | 0.0 | 0.002 | 0.315 | 0.67 | Pass |
| 14 | 0.001 | 0.131 | 0.0 | 0.001 | 0.197 | 0.46 | Pass |
| 15 | 0.001 | 0.150 | 0.0 | 0.001 | 0.225 | 0.63 | Pass |
| 16 | 0.001 | 0.115 | 0.0 | 0.001 | 0.173 | 0.61 | Pass |
| 17 | 0.001 | 0.132 | 0.0 | 0.001 | 0.199 | 0.50 | Pass |
| 18 | 0.001 | 0.102 | 0.0 | 0.001 | 0.153 | 0.68 | Pass |
| 19 | 0.001 | 0.118 | 0.0 | 0.001 | 0.178 | 0.75 | Pass |
| 20 | 0.001 | 0.092 | 0.0 | 0.001 | 0.138 | 0.78 | Pass |
| 21 | 0.001 | 0.107 | 0.0 | 0.001 | 0.161 | 0.80 | Pass |
| 22 | 0.001 | 0.084 | 0.0 | 0.001 | 0.125 | 0.54 | Pass |
| 23 | 0.001 | 0.098 | 0.0 | 0.001 | 0.147 | 0.89 | Pass |
| 24 | 0.000 | 0.077 | 0.0 | 0.001 | 0.115 | 0.45 | Pass |
| 25 | 0.001 | 0.090 | 0.0 | 0.001 | 0.135 | 0.96 | Pass |
| 26 | 0.001 | 0.071 | 0.0 | 0.001 | 0.106 | 0.60 | Pass |
| 27 | 0.001 | 0.083 | 0.0 | 0.001 | 0.125 | 0.87 | Pass |
| 28 | 0.000 | 0.066 | 0.0 | 0.000 | 0.099 | 0.49 | Pass |
| 29 | 0.001 | 0.078 | 0.0 | 0.001 | 0.116 | 0.84 | Pass |
| 30 | 0.001 | 0.061 | 0.0 | 0.001 | 0.092 | 0.66 | Pass |
| 31 | 0.001 | 0.073 | 0.0 | 0.001 | 0.109 | 0.97 | Pass |
| 32 | 0.000 | 0.058 | 0.0 | 0.000 | 0.086 | 0.56 | Pass |
| 33 | 0.001 | 0.068 | 0.0 | 0.001 | 0.102 | 0.93 | Pass |
| 34 | 0.000 | 0.054 | 0.0 | 0.000 | 0.081 | 0.52 | Pass |
| 35 | 0.001 | 0.064 | 0.0 | 0.001 | 0.096 | 0.98 | Pass |
| 36 | 0.000 | 0.051 | 0.0 | 0.000 | 0.077 | 0.53 | Pass |
| 37 | 0.001 | 0.061 | 0.0 | 0.001 | 0.091 | 0.91 | Pass |
| 38 | 0.000 | 0.048 | 0.0 | 0.000 | 0.073 | 0.55 | Pass |
| 39 | 0.001 | 0.058 | 0.0 | 0.001 | 0.087 | 1.14 | Pass |
| 40 | 0.000 | 0.046 | 0.0 | 0.001 | 0.069 | 0.76 | Pass |

5.5 Measurement Uncertainty

The measurement uncertainty for harmonic test is under consideration according to CISPR 16-4-2:2003.

6 Flicker

Test Result: Pass

6.1 Used Test Equipment

| Equip. No. | Equipment | Model | Manufacturer |
|------------|--------------------------------|--------------------|-----------------------|
| EM001-02 | Harmonic & Flicker Test System | 5001IX-CTS-400-413 | California Instrument |

6.2 Block Diagram of Test Setup

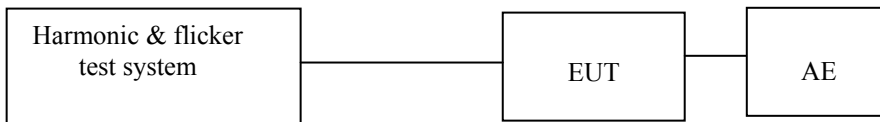

6.3 Test Setup and Procedure

6.3.1 Definition

- Flicker: impression of unsteadiness of visual sensation induced by a lighting stimulus whose luminance or spectral distribution fluctuates with time.
- Pst: Short-term flicker indicator The flicker severity evaluated over a short period (in minutes); Pst=1 is the conventional threshold of irritability
- Plt: long-term flicker indicator; the flicker severity evaluated over a long period (a few hours). Using successive Pst value.
- dc: the relative steady-state voltage change
- dmax: the maximum relative voltage change
- d(t): the value during a voltage change

6.3.2 Test condition

The EUT was set to produce the most unfavourable sequence of voltage changes.

6.4 Test Data

Flicker Test Summary (Run time)

Test Result: Pass

Status: Test Completed

Pst, and limit line

European Limits

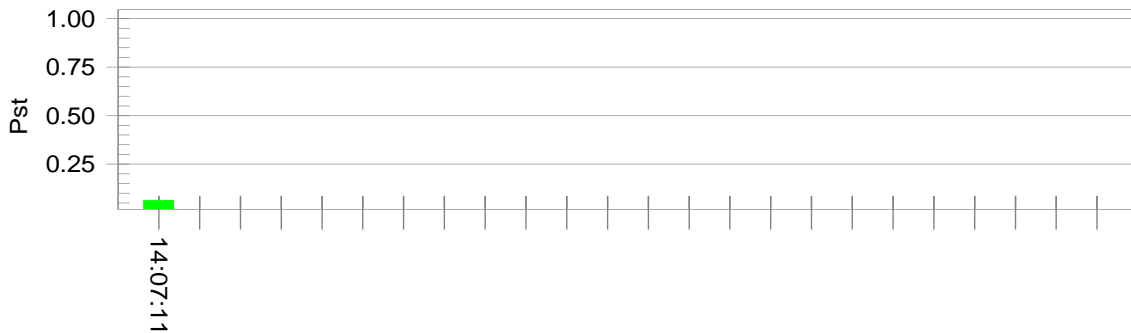

Time is too short for Plt plot

Parameter values recorded during the test:

| | | | | |
|---------------------------------|--------|------------------|-------|------|
| Vrms at the end of test (Volt): | 226.90 | | | |
| Highest dt (%): | 0.00 | Test limit (%): | 3.30 | Pass |
| Time(mS) > dt: | 0.0 | Test limit (mS): | 500.0 | Pass |
| Highest dc (%): | 0.00 | Test limit (%): | 3.30 | Pass |
| Highest dmax (%): | 0.00 | Test limit (%): | 4.00 | Pass |
| Highest Pst (10 min. period): | 0.064 | Test limit: | 1.000 | Pass |

6.5 Measurement Uncertainty

Measurement uncertainty for voltage fluctuation and flicker is under consideration according to CISPR 16-4-2:2003.

7 Appendix I - Photos of test setup

Conducted Emission

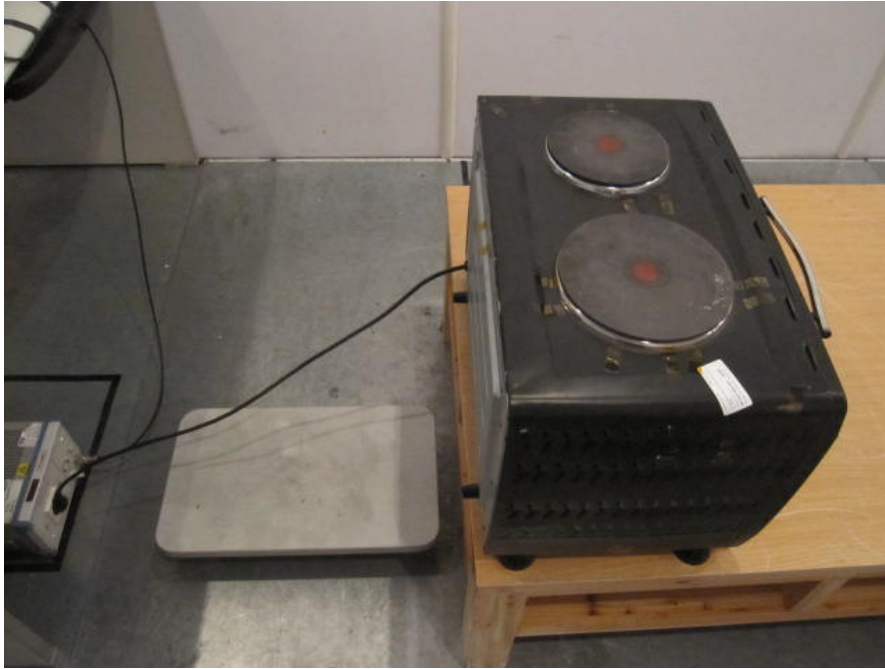

Radiated Power



Clicks



Harmonics and Flicker

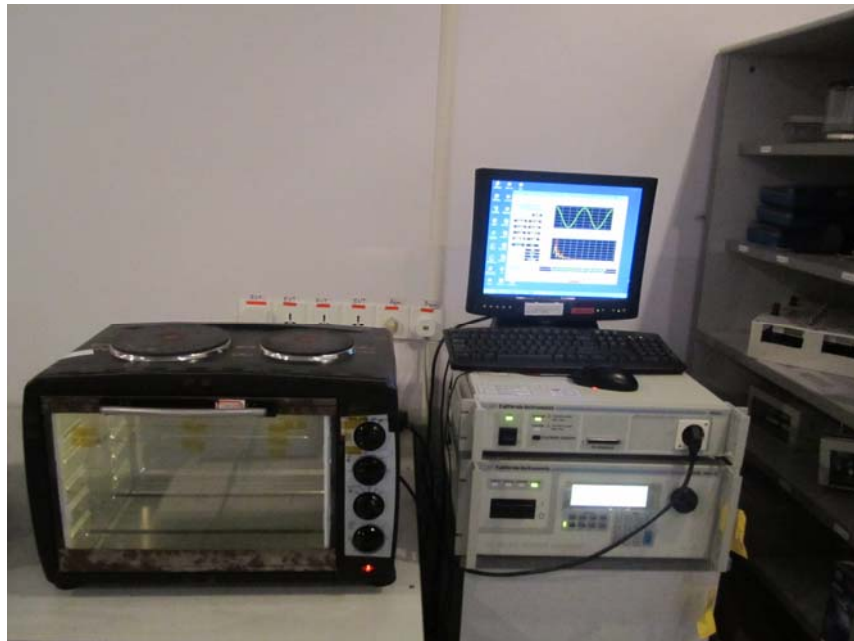

8 Appendix II - Photos of EUT

Overall view of GR28, GR28L, GR28C, GR28RC, GR28R, GR28RL, GR28CL, GR28RCL



Overall view of GR28H3, GR28H3L, GR28CH3, GR28RCH3, GR28CH3L, GR28RH3, GR28RH3L, GR28RCH3L



Inner view of GR28CH3L

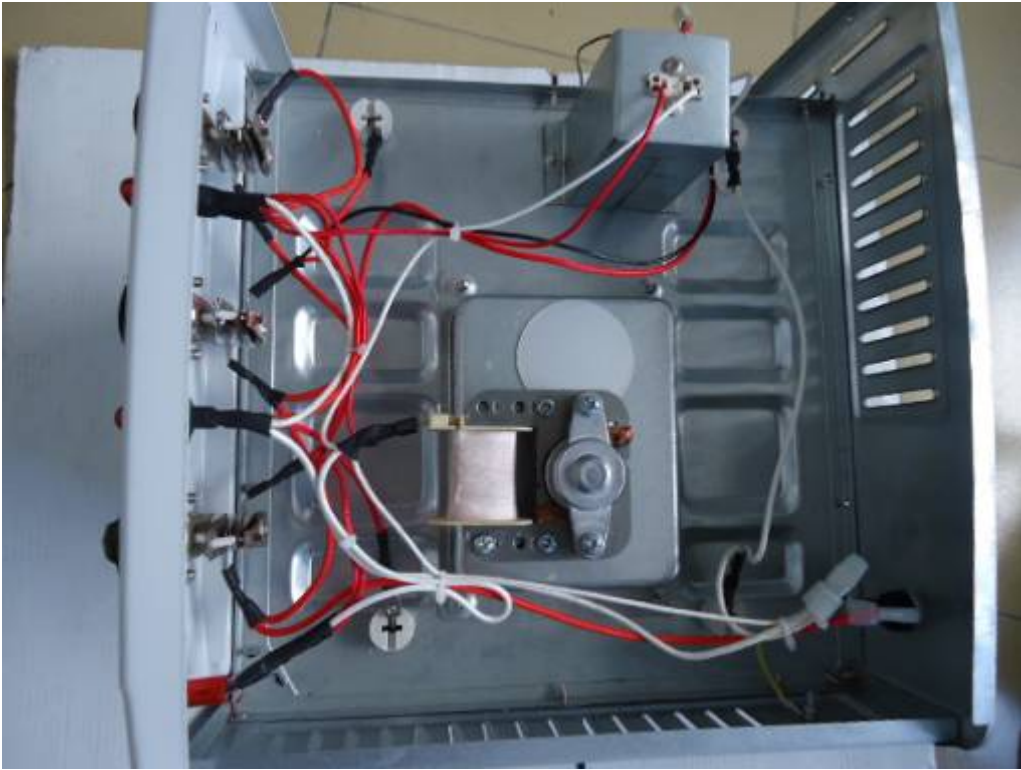

Overall view of pilot lamp and lamp-holder for all models with pilot lamp

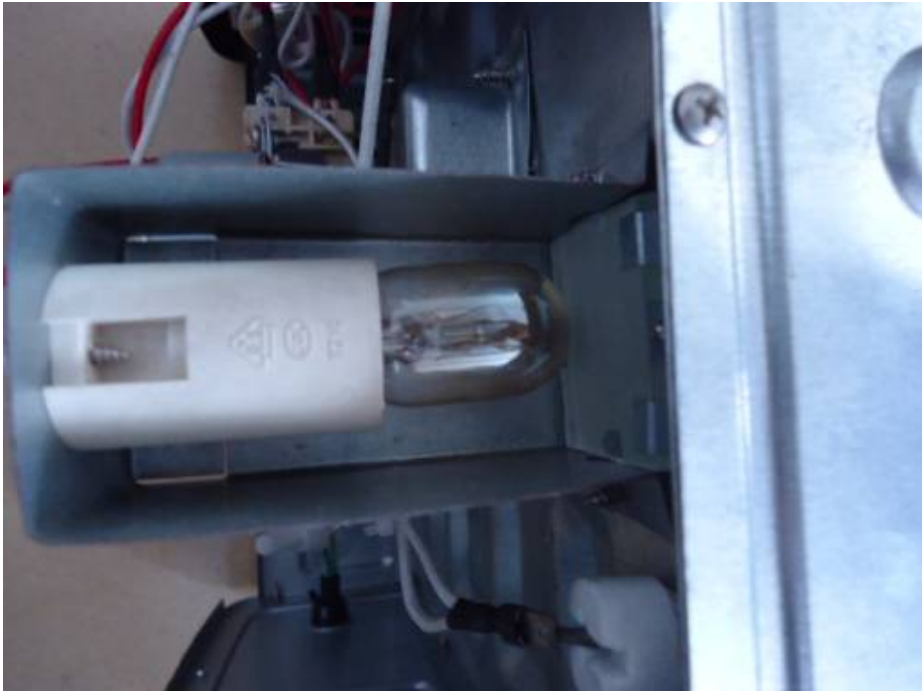

Overall view of GR33, GR33L, GR33C, GR33RC, GR33R, GR33RL, GR33CL, GR33RCL



Overall view of GR33H3, GR33H3L, GR33CH3, GR33RCH3, GR33CH3L, GR33RH3L, GR33RCH3L, GR33RH3L



Inner view of GR33RCH3L



Overall view of GR35, GR35R, GR35C, GR35L, GR35RC, GR35RL, GR35CL, GR35RCL



Overall view of GR35H3, GR35H3L, GR35CH3, GR35RCH3, GR35CH3L, GR35RH3L, GR35RCH3L, GR35RH3L



Inner view of GR35CH3L

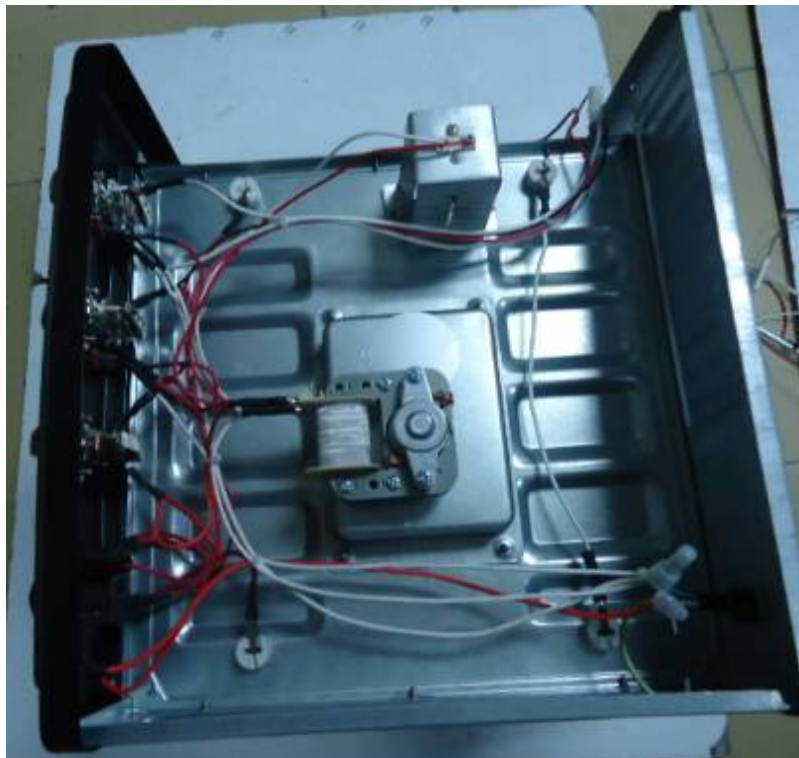

Overall view of GR48, GR48R, GR48C, GR48L, GR48RC, GR48RL, GR48CL, GR48RCL



Overall view of GR48H3, GR48H3L, GR48CH3, GR48RCH3, GR48CH3L, GR48RH3L, GR48RCH3L, GR48RH3L



Inner view of GR48RCH3L

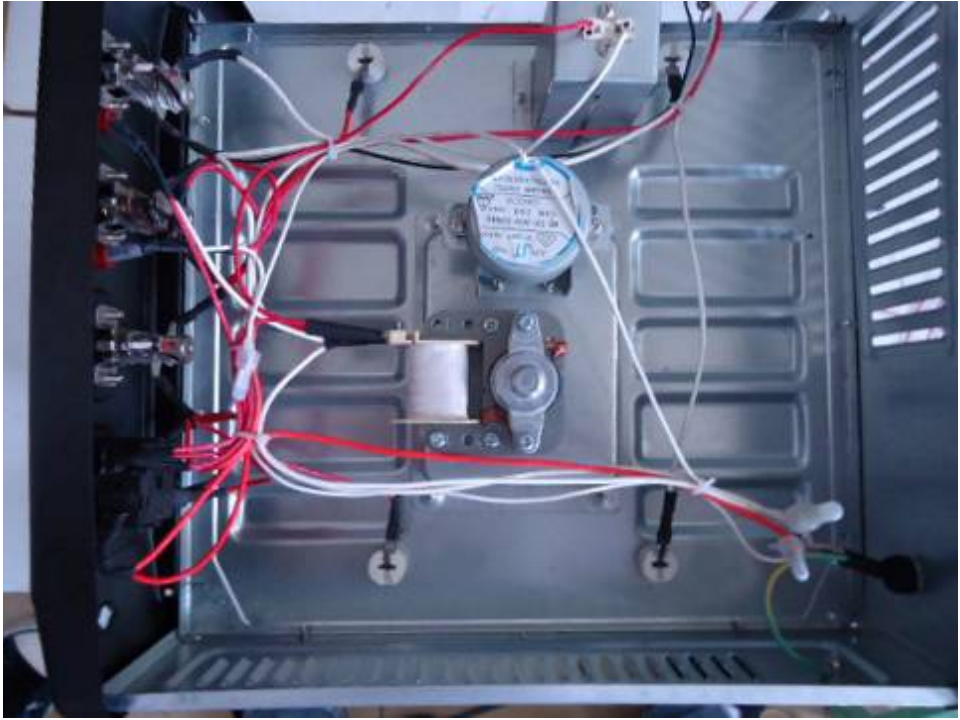

Overall view of swing motor

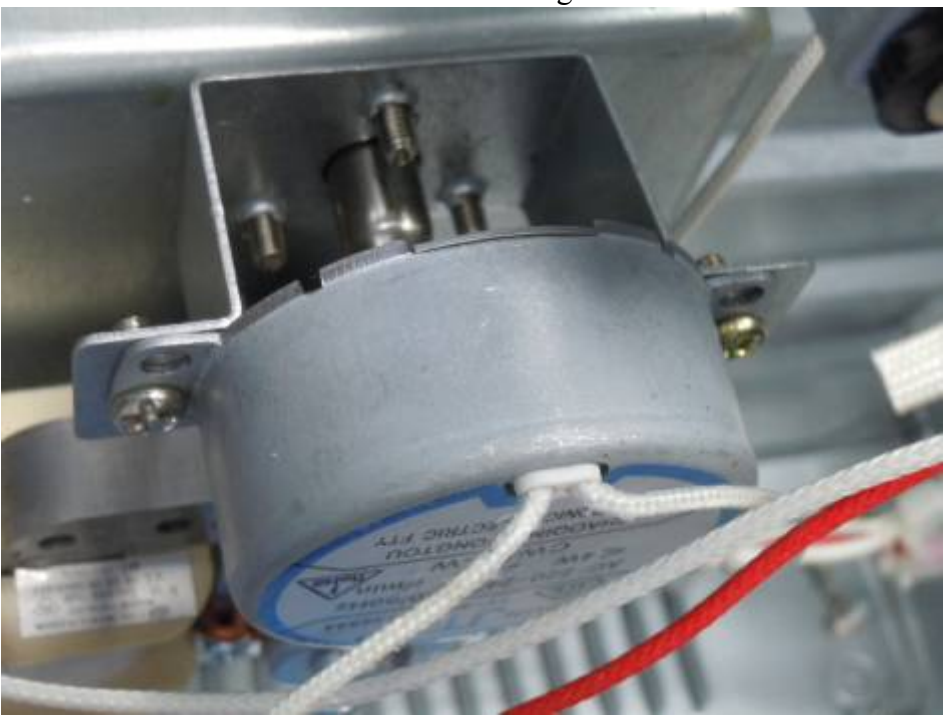

Overall view of fan motor

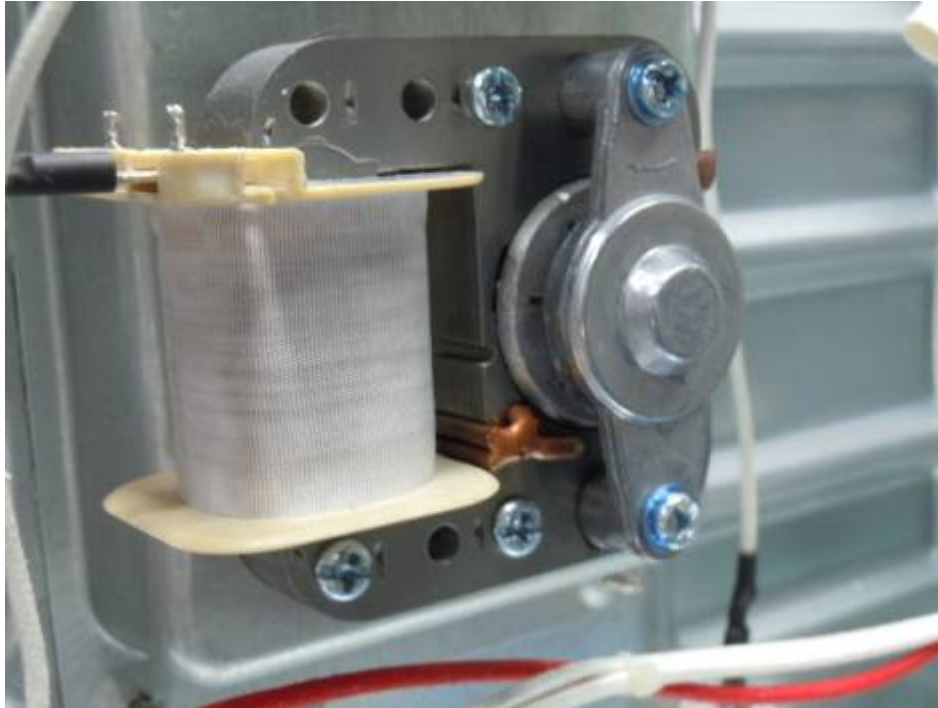

Overall view of thermostat



Overall view of bigger heater



Overall view of smaller heater

