



**EUROFINS PRODUCT TESTING SERVICE (SHANGHAI) CO., LTD.**

# **EMC TEST- REPORT**

**TEST REPORT NUMBER: EFSH18052923-IE-02-E01**



Eurofins Product Testing Service (Shanghai) Co., Ltd.  
No.395 West Jiangchang Road, Jing'an District, Shanghai,  
200436, P.R. China

Phone: +86-21-61819181  
Fax: +86-21-61819180  
Page 1 of 44

## TABLE OF CONTENTS

### 1 Contents

<b>1</b>	<b>Contents</b>	<b>2</b>
<b>2</b>	<b>General Information</b>	<b>3</b>
2.1	Notes	3
2.2	Testing laboratory	4
2.3	Details of approval holder	5
2.4	Application details	5
2.5	EUT information	5
2.6	Test standards	5
<b>3</b>	<b>Technical test</b>	<b>6</b>
3.1	Summary of test results	6
3.2	Test environment	6
3.3	Test equipment utilized	7
3.4	Test results	8
<b>4</b>	<b>Emission Test</b>	<b>9</b>
4.1	Conducted Emission	9
4.2	Disturbance power	14
4.3	Discontinuous disturbance	17
4.4	Harmonic Current Emissions	19
4.5	Voltage Changes, Voltage Fluctuations and Flicker	24
<b>5</b>	<b>Immunity Test</b>	<b>26</b>
5.1	Performance Criteria Description in Clause 6 of EN 55014-2	26
5.2	Classification of apparatus	26
5.3	ESD	27
5.4	Electrical Fast Transients	28
5.5	Surge Immunity	29
5.6	Injected currents(RF continues conducted)	30
5.7	Voltage dips and Interruption	31
<b>6</b>	<b>Test Setup Photos</b>	<b>32</b>
<b>7</b>	<b>EUT Photos</b>	<b>35</b>

## 2 General Information

### 2.1 Notes

The results of this test report relate exclusively to the item tested as specified in chapter "Description of test item" and are not transferable to any other test items.

Eurofins Product Testing Service (Shanghai) Co., Ltd. is not responsible for any generalisations and conclusions drawn from this report. Any modification of the test item can lead to invalidity of test results and this test report may therefore be not applicable to the modified test item.

The test report may only be reproduced or published in full. Reproducing or publishing extracts of the report requires the prior written approval of the Eurofins Product Testing Service (Shanghai) Co., Ltd.

This document is subject to the General Terms and Conditions and the Testing and Certification System of Eurofins Product Testing Service (Shanghai) Co., Ltd., available on request or accessible at [www.pt.eurofins.com](http://www.pt.eurofins.com).

#### Operator:

2018-07-23

Perry Li / Testing Engineer



Date

Eurofins-Lab.

Name / Title

Signature

#### Technical responsibility for area of testing:

2018-07-23

Stefan Zhao / Project Engineer



Date

Eurofins

Name / Title

Signature

Test Report No.: EFSH18052923-IE-02-E01

Eurofins Product Testing Service (Shanghai) Co., Ltd.  
No.395 West Jiangchang Road, Jing'an District, Shanghai, 200436, P.R. China



## 2.2 Testing laboratory

### **Eurofins Product Testing Service (Shanghai) Co., Ltd.**

No.395 West Jiangchang Road, Jing'an District, Shanghai, 200436, P.R. China

Telephone : +86-21-61819181

Telefax : +86-21-61819180

**Test location, where different:**

---

Test Report No.: EFSH18052923-IE-02-E01

---

Eurofins Product Testing Service (Shanghai) Co., Ltd.  
No.395 West Jiangchang Road, Jing'an District, Shanghai, 200436, P.R. China

### 2.3 Details of approval holder

Name :  
Address :  
Telephone : ./.  
Fax : ./.

### 2.4 Application details

Date of receipt of application : 2018-05-30  
Date of receipt of test item : 2018-06-15  
Date of test : 2018-06-15 to 2018-07-05

### 2.5 EUT information

Product type : Hot Brush  
Model name : MK-708, MK-919  
Brand name : ./.  
Serial number : ./.  
Ratings : 220-240V~, 50-60Hz, Class II for both models  
MK-708: 55W;  
MK-919: 25W  
Additional information : The products tested in this test report are Hot Brushes for household and indoor use.

After review, below models were selected for all tests.

Test No.	Model name
Model 1	MK-919
Model 2	MK-708

### 2.6 Test standards

Technical standard :

**EN 55014-1: 2017**

**EN 55014-2: 2015**

**EN 61000-3-2: 2014**

**EN 61000-3-3: 2013**

### 3 Technical test

#### 3.1 Summary of test results

No deviations from the technical specification(s) were ascertained in the course of the tests performed.



or

The deviations as specified were ascertained in the course of the tests performed.



#### 3.2 Test environment

Temperature	:	20	...	25°C
Relative humidity content	:	30	...	60%
Air pressure	:	100	...	103kPa

---

Test Report No.: EFSH18052923-IE-02-E01

---

Eurofins Product Testing Service (Shanghai) Co., Ltd.  
No.395 West Jiangchang Road, Jing'an District, Shanghai, 200436, P.R. China

### 3.3 Test equipment utilized

Measurement Equipment List				
No.	Name:	Type:	Manufacturer:	Cal due data:
1	EMI test receiver	ESCI	R&S	2018-11-23
2	Single phase Harmonics & Flicker analyser	PACS-1	California Instruments	2018-11-23
3	AC Power Source	5001ix	California Instruments	2018-11-23
4	Coupling/Decoupling Network	L 801 M2/M3	Luethi	2018-11-23
5	Ultra Compact Simulator	UCS 500N7	EMTEST	2018-11-23
6	ESD Gun	NSG 437	TESEQ	2018-07-20
7	Current transformer	MC2630	EMTEST	2018-11-23
8	Motorized variac	MV2616	EMTEST	2018-11-23
9	Continuous wave simulator	CWS500N1	EMTEST	2018-11-23
10	Magnetic field coil	MS100	EMTEST	2018-11-23
11	Current transformer	MC26100	EMTEST	2018-11-23
12	Artificial mains	ENV216	R&S	2018-11-23
13	Click analyser	CL55C	AFJ	2018-09-09
14	Absorbing clamp	MDS21	Luethi	2018-11-23
15	EM clamp	EM101	Luethi	2018-11-23

---

Test Report No.: EFSH18052923-IE-02-E01

---

Eurofins Product Testing Service (Shanghai) Co., Ltd.  
 No.395 West Jiangchang Road, Jing'an District, Shanghai, 200436, P.R. China

### 3.4 Test results

 1st test

 test after modification

 production test

Test case	Subclause	Required	Test passed	Test failed
Conducted Emission	Clause 4.3.3 of EN 55014-1	<input checked="" type="checkbox"/>	<input checked="" type="checkbox"/>	<input type="checkbox"/>
Disturbance power	Clause 4.3.4.4 of EN 55014-1	<input checked="" type="checkbox"/>	<input checked="" type="checkbox"/>	<input type="checkbox"/>
Radiated disturbance	Clause 4.3.4.5 of EN 55014-1	<input type="checkbox"/>	<input type="checkbox"/>	<input type="checkbox"/>
Discontinuous disturbance	Clause 4.4 of EN 55014-1	<input checked="" type="checkbox"/>	<input checked="" type="checkbox"/>	<input type="checkbox"/>
Harmonic Current Emissions	EN 61000-3-2	<input checked="" type="checkbox"/>	<input checked="" type="checkbox"/>	<input type="checkbox"/>
Voltage Changes, Voltage Fluctuations and Flicker	EN 61000-3-3	<input checked="" type="checkbox"/>	<input checked="" type="checkbox"/>	<input type="checkbox"/>
Electrostatic Discharge	Clause 5.1 of EN 55014-2 & IEC 61000-4-2	<input checked="" type="checkbox"/>	<input checked="" type="checkbox"/>	<input type="checkbox"/>
Electrical Fast Transients	Clause 5.2 of EN 55014-2 & IEC 61000-4-4	<input checked="" type="checkbox"/>	<input checked="" type="checkbox"/>	<input type="checkbox"/>
Injected currents (RF continues conducted)	Clause 5.3 & 5.4 of EN 55014-2 & IEC 61000-4-6	<input checked="" type="checkbox"/>	<input checked="" type="checkbox"/>	<input type="checkbox"/>
Radio frequency electromagnetic fields	Clause 5.5 of EN 55014-2 & IEC 61000-4-3	<input type="checkbox"/>	<input type="checkbox"/>	<input type="checkbox"/>
Surge immunity	Clause 5.6 of EN 55014-2 & IEC 61000-4-5	<input checked="" type="checkbox"/>	<input checked="" type="checkbox"/>	<input type="checkbox"/>
Voltage dips and Interruption	Clause 5.7 of EN 55014-2 & IEC 61000-4-11	<input checked="" type="checkbox"/>	<input checked="" type="checkbox"/>	<input type="checkbox"/>

Note 1: The additional margin(0 to 10dB) was meet in the frequency range 200MHz to 300MHz in Disturbance power test(absorbing clamp), and the EUT did not contained any circuit with clock frequency more than 30MHz, so the EUT was compliant with the Radiated disturbance test (300MHz-1GHz) without test.

Note 2: The Radio frequency electromagnetic fields test was not required as the appliance did not contain clock frequency higher than 15MHz.

---

Test Report No.: EFSH18052923-IE-02-E01

Eurofins Product Testing Service (Shanghai) Co., Ltd.  
No.395 West Jiangchang Road, Jing'an District, Shanghai, 200436, P.R. China

## 4 Emission Test

### 4.1 Conducted Emission

This clause lays down the general requirements for the measurement of disturbance voltage produced at the terminals of apparatus.

#### 4.1.1 Limits

Frequency range MHz	At mains terminals dB ( $\mu$ V)	
	Quasi-peak Limit	Average Limit
0.15 to 0.50	66 to 56	59 to 46
0.50 to 5	56	46
5 to 30	60	50

Note1: The limit decreases linearly with the logarithm of the frequency in the range 0.15 MHz to 30 MHz.

Note2: The lower limit is applicable at the transition frequency.

#### 4.1.2 Measurement procedure

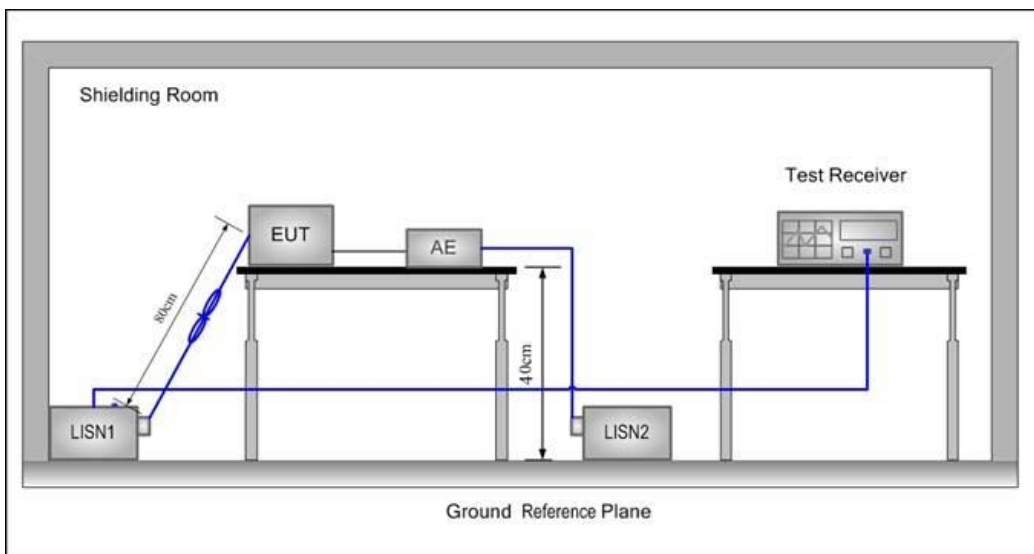

1. The mains terminal disturbance voltage was measured with the EUT in a shielded room.
2. The EUT was connected to AC power source through a LISN (Line Impedance Stabilization Network) which provides a  $(50 \mu H + 5 \Omega) \parallel 50 \Omega$  linear impedance. The power cables of all other units of the EUT were connected to a second LISN, which was bonded to the ground reference plane in the same way as the LISN for the unit being measured.
3. The tabletop EUT was placed upon a non-metallic table 0.4m above the ground reference plane. And for floor-standing arrangement, the EUT was placed on the horizontal ground reference plane, but separated from metallic contact with the ground reference plane by 0.1m of insulation.

Test Report No.: EFSH18052923-IE-02-E01

Eurofins Product Testing Service (Shanghai) Co., Ltd.  
No.395 West Jiangchang Road, Jing'an District, Shanghai, 200436, P.R. China

4. According to a pre-test at 160kHz, the worst rating voltage was selected for final test. Before get the final emission results with quasi-peak(QP) detector and average(AVG) detector, a pre-scan was performed with the peak(PK) and average(AVG) detector to find out the maximum emission data plots of the EUT.

#### 4.1.3 Measurement uncertainty

$U_{lab}(cond) = 2.5dB$  at 95% level of confidence,  $k=2$

#### 4.1.4 Results -Measurement Data

**Model 1**  
**Live Line:**  
**Level**

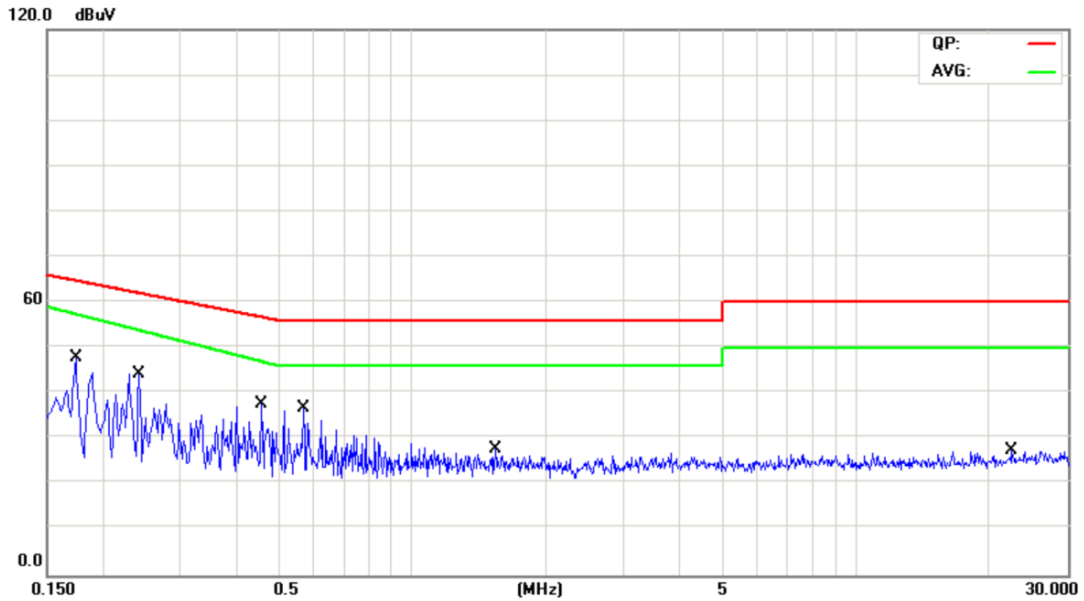

No.	Mk.	Freq.	Reading Level	Correct Factor	Measurement	Limit	Over	Detector
		MHz	dBuV	dB	dBuV	dBuV	dB	
1		0.1740	30.62	10.36	40.98	64.77	-23.79	QP
2		0.1740	11.06	10.36	21.42	57.40	-35.98	AVG
3	*	0.2420	32.69	10.47	43.16	62.03	-18.87	QP
4		0.2420	11.36	10.47	21.83	53.84	-32.01	AVG
5		0.4580	8.97	10.37	19.34	56.73	-37.39	QP
6		0.4580	5.77	10.37	16.14	46.95	-30.81	AVG
7		0.5700	8.82	10.37	19.19	56.00	-36.81	QP
8		0.5700	5.73	10.37	16.10	46.00	-29.90	AVG
9		1.5380	8.65	10.46	19.11	56.00	-36.89	QP
10		1.5380	5.56	10.46	16.02	46.00	-29.98	AVG
11		22.4540	10.38	10.45	20.83	60.00	-39.17	QP
12		22.4540	5.40	10.45	15.85	50.00	-34.15	AVG

Test Report No.: EFSH18052923-IE-02-E01

Eurofins Product Testing Service (Shanghai) Co., Ltd.  
No.395 West Jiangchang Road, Jing'an District, Shanghai, 200436, P.R. China

**Neutral Line:  
Level**

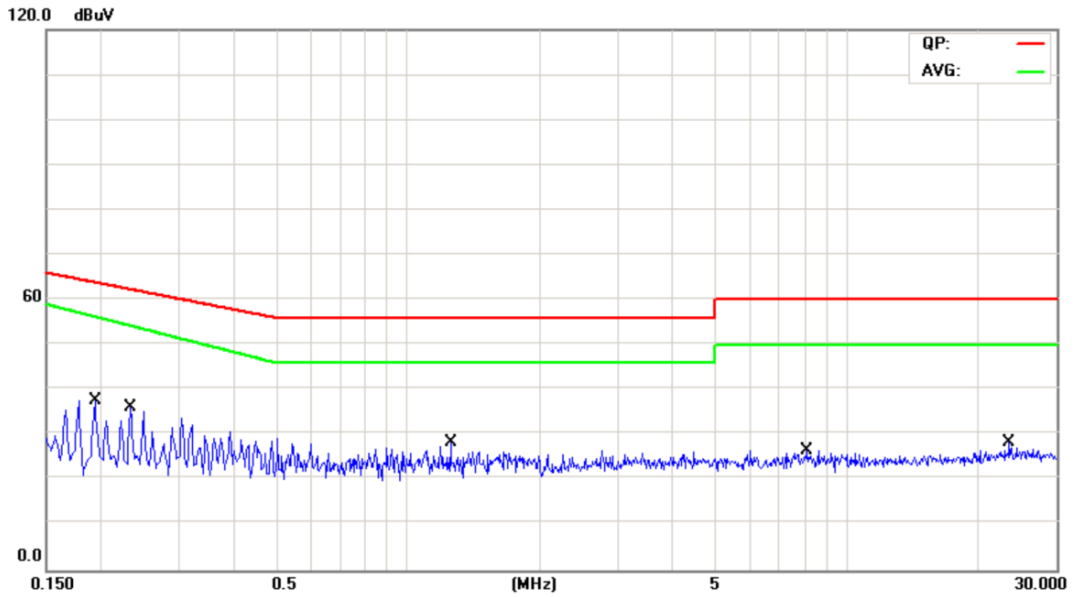

No.	Mk.	Freq.	Reading Level	Correct Factor	Measurement	Limit	Over	Detector
		MHz	dBuV	dB	dBuV	dBuV	dB	
1		0.1940	20.60	10.31	30.91	63.86	-32.95	QP
2		0.1940	7.99	10.31	18.30	56.22	-37.92	AVG
3		0.2340	18.47	10.29	28.76	62.30	-33.54	QP
4		0.2340	7.44	10.29	17.73	54.19	-36.46	AVG
5		1.2540	8.68	10.40	19.08	56.00	-36.92	QP
6	*	1.2540	5.47	10.40	15.87	46.00	-30.13	AVG
7		8.1339	9.29	10.36	19.65	60.00	-40.35	QP
8		8.1339	4.65	10.36	15.01	50.00	-34.99	AVG
9		23.5060	9.26	10.54	19.80	60.00	-40.20	QP
10		23.5060	9.46	10.54	20.00	60.00	-40.00	QP
11		23.5060	4.64	10.54	15.18	50.00	-34.82	AVG
12		23.5060	4.68	10.54	15.22	50.00	-34.78	AVG

Test Report No.: EFSH18052923-IE-02-E01

Eurofins Product Testing Service (Shanghai) Co., Ltd.  
No.395 West Jiangchang Road, Jing'an District, Shanghai, 200436, P.R. China

**Model 2**  
**Live Line:**  
**Level**

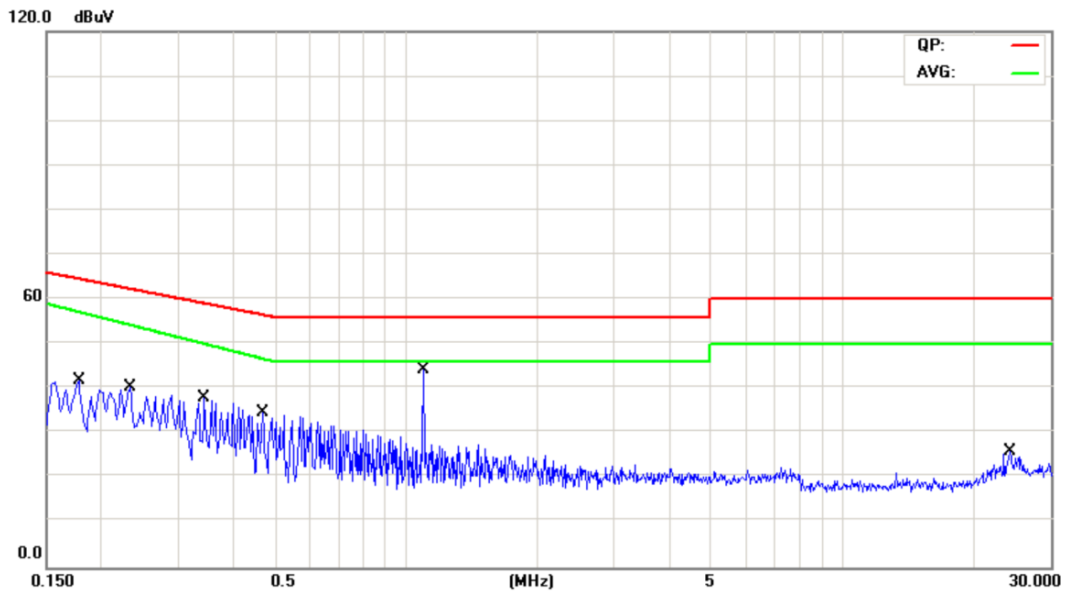

No.	Mk.	Freq.	Reading	Correct	Measure-	Limit	Over	
		MHz	Level	Factor	ment			Detector
			dBuV	dB	dBuV	dBuV	dB	
1	*	0.1780	24.96	10.33	35.29	64.58	-29.29	QP
2		0.1780	4.60	10.33	14.93	57.15	-42.22	AVG
3		0.2340	21.86	10.47	32.33	62.31	-29.98	QP
4		0.2340	3.35	10.47	13.82	54.20	-40.38	AVG
5		0.3460	18.68	10.42	29.10	59.06	-29.96	QP
6		0.3460	1.59	10.42	12.01	49.98	-37.97	AVG
7		0.4700	15.74	10.36	26.10	56.51	-30.41	QP
8		0.4700	0.97	10.36	11.33	46.67	-35.34	AVG
9		1.0940	8.62	10.46	19.08	56.00	-36.92	QP
10		1.0940	0.18	10.46	10.64	46.00	-35.36	AVG
11		24.1700	7.59	10.43	18.02	60.00	-41.98	QP
12		24.1700	0.93	10.43	11.36	50.00	-38.64	AVG

Test Report No.: EFSH18052923-IE-02-E01

Eurofins Product Testing Service (Shanghai) Co., Ltd.  
No.395 West Jiangchang Road, Jing'an District, Shanghai, 200436, P.R. China

**Neutral Line:  
Level**

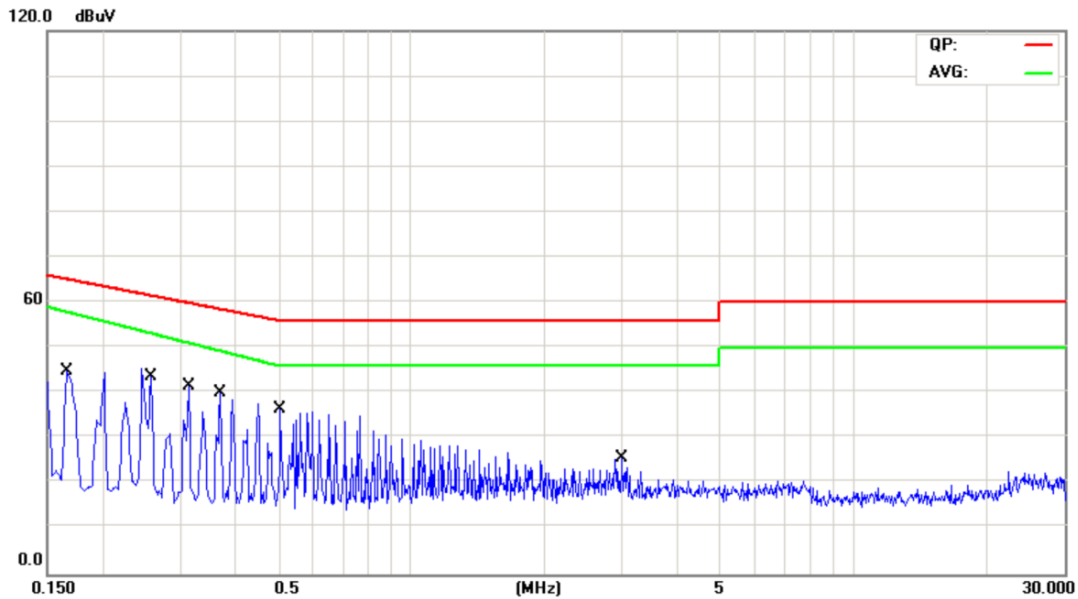

No.	Mk.	Freq. MHz	Reading Level dBuV	Correct Factor dB	Measure- ment dBuV	Limit dBuV	Over dB	Detector
1		0.1660	26.96	10.30	37.26	65.15	-27.89	QP
2		0.1660	5.44	10.30	15.74	57.90	-42.16	AVG
3		0.2580	22.61	10.29	32.90	61.49	-28.59	QP
4		0.2580	2.80	10.29	13.09	53.14	-40.05	AVG
5		0.3140	20.60	10.30	30.90	59.86	-28.96	QP
6		0.3140	2.99	10.30	13.29	51.02	-37.73	AVG
7	*	0.3700	21.17	10.31	31.48	58.50	-27.02	QP
8		0.3700	1.65	10.31	11.96	49.25	-37.29	AVG
9		0.5060	17.79	10.34	28.13	56.00	-27.87	QP
10		0.5060	1.18	10.34	11.52	46.00	-34.48	AVG
11		2.9980	5.39	10.37	15.76	56.00	-40.24	QP
12		2.9980	-0.30	10.37	10.07	46.00	-35.93	AVG

Test Report No.: EFSH18052923-IE-02-E01

Eurofins Product Testing Service (Shanghai) Co., Ltd.  
No.395 West Jiangchang Road, Jing'an District, Shanghai, 200436, P.R. China

## 4.2 Disturbance power

This clause lays down the general requirements for the measurement of disturbance power produced at the terminals of apparatus.

### 4.2.1 limits

Frequency range MHz	Limit dB (pW)	
	Quasi-peak	Average
30 to 300	45 to 55	35 to 45

Note1: Increasing linearly with the frequency from.

### 4.2.2 Measurement procedure

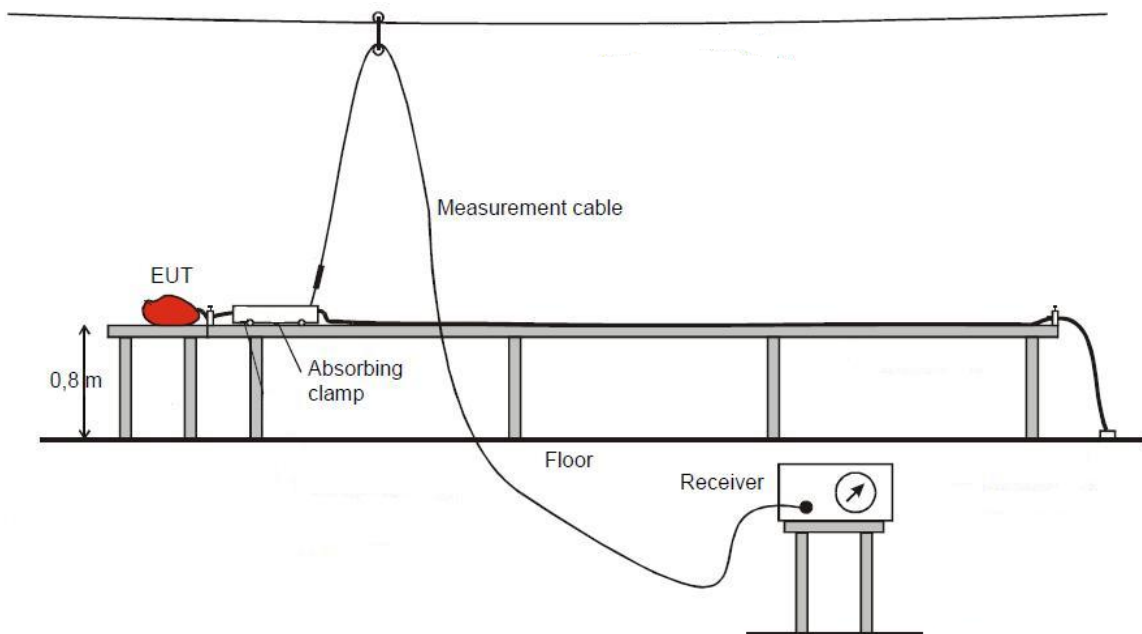

The test configuration corresponds to the standard EN 55014-1. The equipment under test is placed on a non metallic table with 0,8 m high. The lead to be measured is stretched horizontally in a straight line, to permit variation in position of the absorbing clamp along the lead to find the maximum indication. The lead shall be at least length of 6 meter. According to a pre-test at 50MHz, the worst rating voltage was selected for final test. Before get the final emission results with quasi-peak(QP) detector and average(AVG) detector, a pre-scan was performed with the peak(PK) detector to find out the maximum emission data plots of the EUT. The absorbing clamp is placed around the lead.

### 4.2.3 Measurement uncertainty

$U_{lab(cond)} = 4.08 \text{ dB}$  at confidence of 95%,  $k=2$

Test Report No.: EFSH18052923-IE-02-E01

Eurofins Product Testing Service (Shanghai) Co., Ltd.  
No.395 West Jiangchang Road, Jing'an District, Shanghai, 200436, P.R. China

#### 4.2.4 Results

**Model 1  
Level**

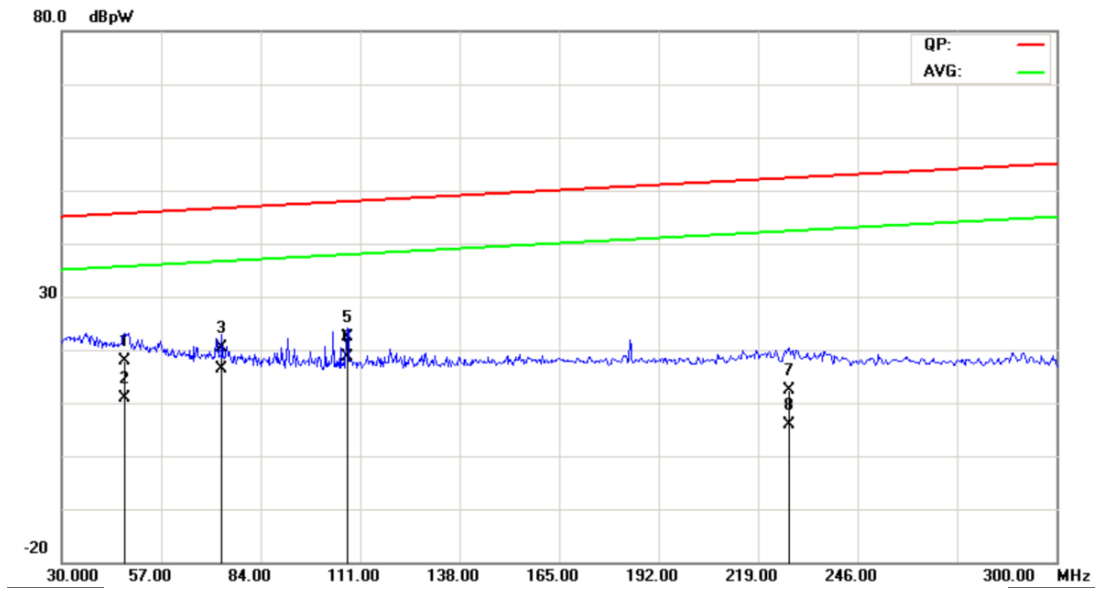

No.	Mk.	Freq. MHz	Reading Level dBpW	Correct Factor dB	Measure- ment dBpW	Limit dBpW	Over dB	Detector
1		47.1600	-1.29	19.10	17.81	45.64	-27.83	QP
2		47.1600	-8.20	19.10	10.90	35.64	-24.74	AVG
3		73.7200	3.40	16.99	20.39	46.62	-26.23	QP
4		73.7200	-0.69	16.99	16.30	36.62	-20.32	AVG
5		107.7200	6.12	16.18	22.30	47.88	-25.58	QP
6	*	107.7200	2.42	16.18	18.60	37.88	-19.28	AVG
7		227.4000	-3.56	16.05	12.49	52.31	-39.82	QP
8		227.4000	-10.15	16.05	5.90	42.31	-36.41	AVG

Test Report No.: EFSH18052923-IE-02-E01

Eurofins Product Testing Service (Shanghai) Co., Ltd.  
No.395 West Jiangchang Road, Jing'an District, Shanghai, 200436, P.R. China

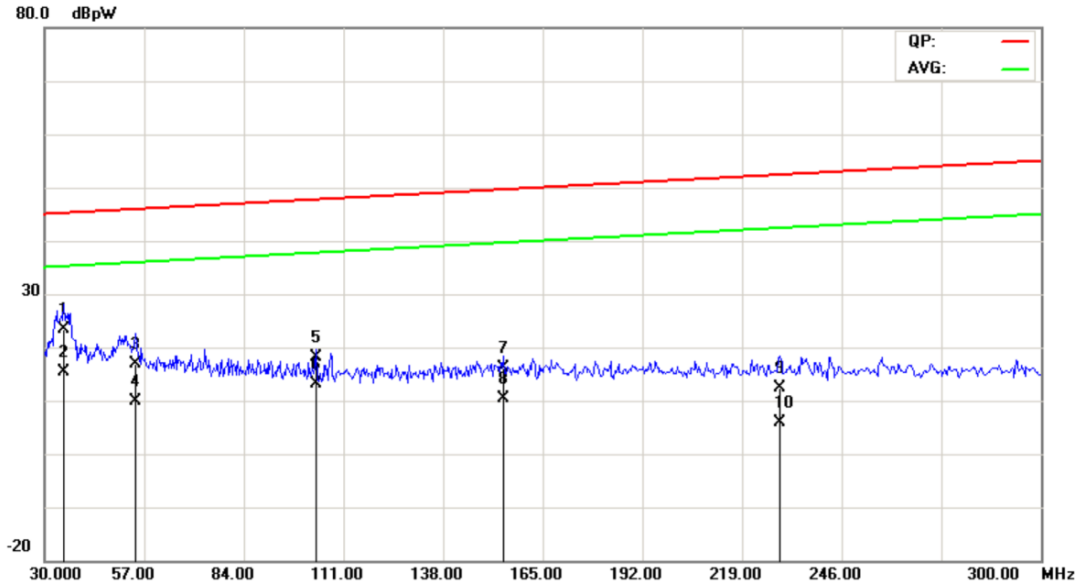
**Model 2  
Level**

No.	Mk.	Freq. MHz	Reading Level dBpW	Correct Factor dB	Measure- ment dBpW	Limit dBpW	Over dB	Detector
1		35.3600	3.62	19.83	23.45	45.20	-21.75	QP
2	*	35.3600	-4.33	19.83	15.50	35.20	-19.70	AVG
3		54.6400	-1.54	18.30	16.76	45.91	-29.15	QP
4		54.6400	-8.30	18.30	10.00	35.91	-25.91	AVG
5		103.6800	1.99	16.19	18.18	47.73	-29.55	QP
6		103.6800	-3.09	16.19	13.10	37.73	-24.63	AVG
7		154.4400	0.01	16.09	16.10	49.61	-33.51	QP
8		154.4400	-5.79	16.09	10.30	39.61	-29.31	AVG
9		229.4000	-3.66	16.06	12.40	52.39	-39.99	QP
10		229.4000	-10.26	16.06	5.80	42.39	-36.59	AVG

---

 Test Report No.: EFSH18052923-IE-02-E01
 

---

 Eurofins Product Testing Service (Shanghai) Co., Ltd.  
 No.395 West Jiangchang Road, Jing'an District, Shanghai, 200436, P.R. China

### 4.3 Discontinuous disturbance

Switching operations in thermostatically controlled appliances, automatic programme controlled machines and other electrically controlled or operated appliances generate discontinuous disturbance.

#### 4.3.1 limits

Frequency range MHz	Limit dB ( $\mu$ V)
0.15	66
0.5	56
1.4	56
30	60

#### 4.3.2 Measurement procedure

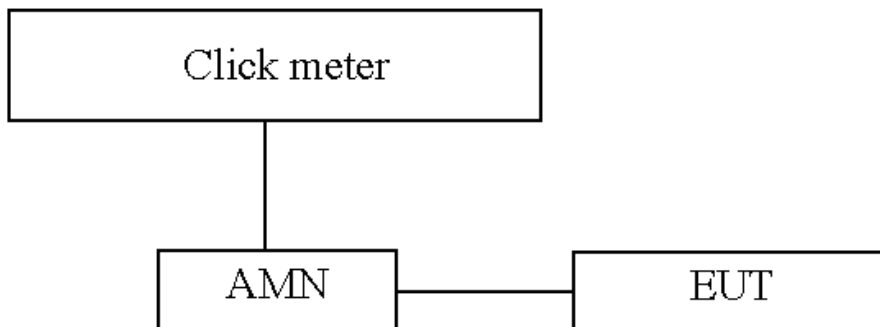

The test configuration is contained inside of a shielded chamber. Receiver compliance to CISPR 16-1-1 with time domain function used during measurement. EUT arrangement was follow EN 55014-1 clause 5.3.3. Operation conditions were follow EN 55014-1 clause 7. 0.15MHz, 0.5MHz, 1.4MHz and 30MHz were spot checked, and upper quartile methods used during measurement. The final judgment of test result was according to figure 6 of EN 55014-1.

---

Test Report No.: EFSH18052923-IE-02-E01

---

Eurofins Product Testing Service (Shanghai) Co., Ltd.  
No.395 West Jiangchang Road, Jing'an District, Shanghai, 200436, P.R. China

### 4.3.3 Results

#### Model 1

Frequency (MHz)	0.15	0.5	1.4	30.0
Permitted limit for continuous interference dB( $\mu$ V)	66.0	56.0	56.0	60.0
Counted click/switch operation number	4	3	3	0
Observed time (min)	120	120	120	120
Click duration (ms)	<10ms	<10ms	<10ms	<10ms
Click rate N	<5	<5	<5	<5
Test result	Pass	Pass	Pass	Pass
Note: The click rate is less than 5, and the click duration is less than 10ms. So it is deemed to comply with limits.				

#### Model 2

Frequency (MHz)	0.15	0.5	1.4	30.0
Permitted limit for continuous interference dB( $\mu$ V)	66.0	56.0	56.0	60.0
Counted click/switch operation number	5	4	1	1
Observed time (min)	120	120	120	120
Click duration (ms)	<10ms	<10ms	<10ms	<10ms
Click rate N	<5	<5	<5	<5
Test result	Pass	Pass	Pass	Pass
Note: The click rate is less than 5, and the click duration is less than 10ms. So it is deemed to comply with limits.				

---

Test Report No.: EFSH18052923-IE-02-E01

Eurofins Product Testing Service (Shanghai) Co., Ltd.  
No.395 West Jiangchang Road, Jing'an District, Shanghai, 200436, P.R. China

## 4.4 Harmonic Current Emissions

This part deals with the limitation of harmonic currents injected into the public supply system.

### 4.4.1 Limits

Limit for Class A equipment

Harmonic order n	Maximum permissible harmonic current A
<b>Odd harmonics</b>	
3	2,30
5	1,14
7	0,77
9	0,40
11	0,33
13	0,21
$15 \leq n \leq 39$	$0,15 \frac{15}{n}$
<b>Even harmonics</b>	
2	1,08
4	0,43
6	0,30
$8 \leq n \leq 40$	$0,23 \frac{8}{n}$

### 4.4.2 Measurement procedure

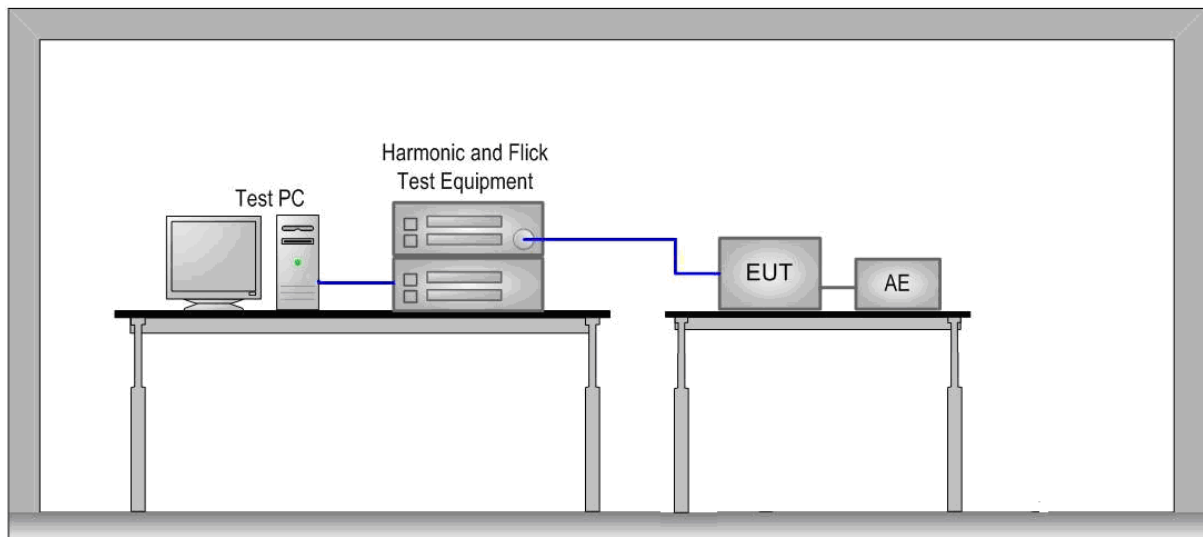

The equipment under test is placed on a wooden table with a height of 0,8 m in the EMC lab. For each harmonic order, measure the 1,5 s smoothed r.m.s. harmonic current in each DFT time window and calculate the arithmetic average of the measured values from the DFT time windows, over the entire observation period. Each harmonic order, all 1.5 s smoothed r.m.s. harmonic current values and the average values for the individual harmonic currents, taken over the entire test observation period shall be less than or equal to the applicable limits.

Test Report No.: EFSH18052923-IE-02-E01

Eurofins Product Testing Service (Shanghai) Co., Ltd.  
No.395 West Jiangchang Road, Jing'an District, Shanghai, 200436, P.R. China

### 4.4.3 Results

#### Model 1 Harmonic

Test Result: Pass      Source qualification: Normal

#### Current & voltage waveforms

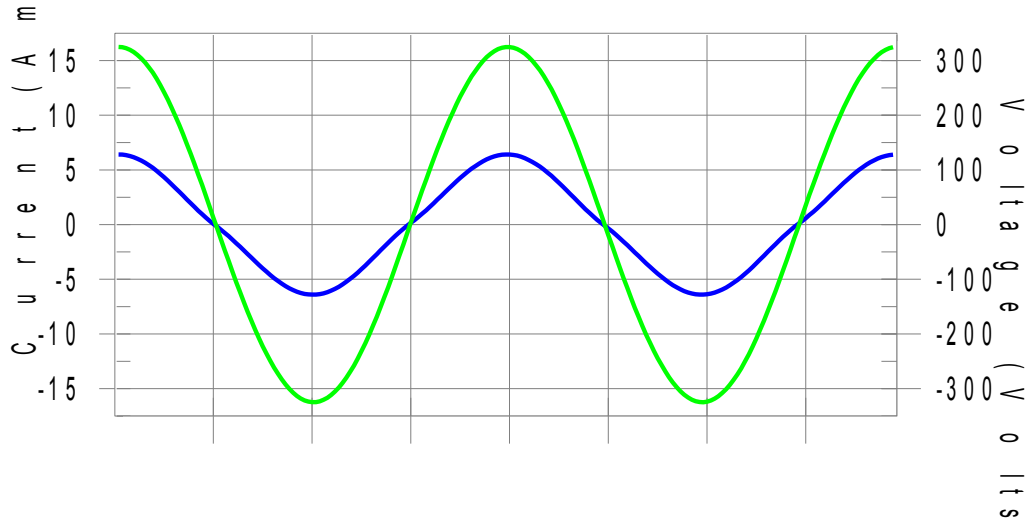

#### Harmonics and Class A limit line

#### European Limits

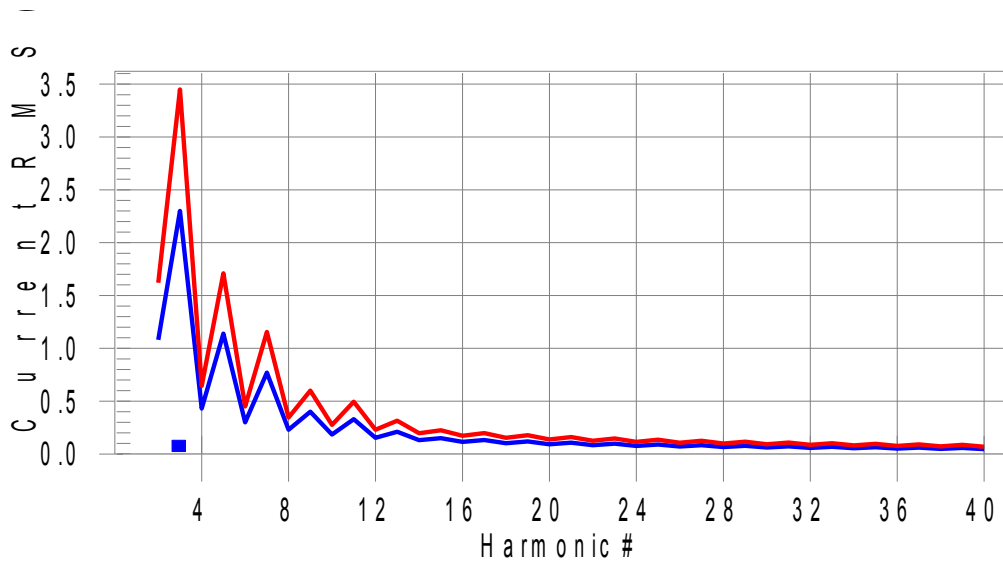

**Test result: Pass    Worst harmonic was #3 with 10.2% of the limit.**

---

Test Report No.: EFSH18052923-IE-02-E01

Eurofins Product Testing Service (Shanghai) Co., Ltd.  
No.395 West Jiangchang Road, Jing'an District, Shanghai, 200436, P.R. China

### Current Test Result Summary

Test Result: Pass      Source qualification: Normal  
 THC(A): 0.130    I-THD(%): 20.9    POHC(A): 0.000    POHC Limit(A): 0.251  
 Highest parameter values during test:

V_RMS (Volts):	230.16	Frequency(Hz):	50.00
I_Peak (Amps):	6.420	I_RMS (Amps):	4.208
I_Fund (Amps):	4.199	Crest Factor:	2.675
Power (Watts):	724.4	Power Factor:	0.998

Harm#	Harms(avg)	100%Limit	%of Limit	Harms(max)	150%Limit	%of Limit	Status
2	0.001	1.080	N/A	0.072	1.620	N/A	Pass
3	0.130	2.300	5.6	0.352	3.450	10.2	Pass
4	0.001	0.430	N/A	0.041	0.645	N/A	Pass
5	0.007	1.140	0.6	0.045	1.710	2.6	Pass
6	0.000	0.300	N/A	0.019	0.450	N/A	Pass
7	0.002	0.770	N/A	0.021	1.155	N/A	Pass
8	0.000	0.230	N/A	0.018	0.345	N/A	Pass
9	0.001	0.400	N/A	0.017	0.600	N/A	Pass
10	0.000	0.184	N/A	0.013	0.276	N/A	Pass
11	0.001	0.330	N/A	0.013	0.495	N/A	Pass
12	0.000	0.153	N/A	0.011	0.230	N/A	Pass
13	0.001	0.210	N/A	0.016	0.315	N/A	Pass
14	0.000	0.131	N/A	0.010	0.197	N/A	Pass
15	0.001	0.150	N/A	0.006	0.225	N/A	Pass
16	0.000	0.115	N/A	0.007	0.173	N/A	Pass
17	0.000	0.132	N/A	0.015	0.198	N/A	Pass
18	0.000	0.102	N/A	0.008	0.153	N/A	Pass
19	0.000	0.118	N/A	0.002	0.178	N/A	Pass
20	0.000	0.092	N/A	0.005	0.138	N/A	Pass
21	0.000	0.107	N/A	0.013	0.161	N/A	Pass
22	0.000	0.084	N/A	0.007	0.125	N/A	Pass
23	0.000	0.098	N/A	0.003	0.147	N/A	Pass
24	0.000	0.077	N/A	0.004	0.115	N/A	Pass
25	0.000	0.090	N/A	0.011	0.135	N/A	Pass
26	0.000	0.071	N/A	0.006	0.107	N/A	Pass
27	0.000	0.083	N/A	0.005	0.125	N/A	Pass
28	0.000	0.066	N/A	0.004	0.099	N/A	Pass
29	0.000	0.078	N/A	0.007	0.116	N/A	Pass
30	0.000	0.061	N/A	0.005	0.092	N/A	Pass
31	0.000	0.073	N/A	0.006	0.109	N/A	Pass
32	0.000	0.058	N/A	0.004	0.086	N/A	Pass
33	0.000	0.068	N/A	0.005	0.102	N/A	Pass
34	0.000	0.054	N/A	0.004	0.081	N/A	Pass
35	0.000	0.064	N/A	0.006	0.096	N/A	Pass
36	0.000	0.051	N/A	0.004	0.077	N/A	Pass
37	0.000	0.061	N/A	0.003	0.091	N/A	Pass
38	0.000	0.048	N/A	0.003	0.073	N/A	Pass
39	0.000	0.058	N/A	0.006	0.087	N/A	Pass
40	0.000	0.046	N/A	0.004	0.069	N/A	Pass

---

Test Report No.: EFSH18052923-IE-02-E01

Eurofins Product Testing Service (Shanghai) Co., Ltd.  
 No.395 West Jiangchang Road, Jing'an District, Shanghai, 200436, P.R. China

**Model 2  
Harmonic**

**Test Result: Pass      Source qualification: Normal**

**Current & voltage waveforms**

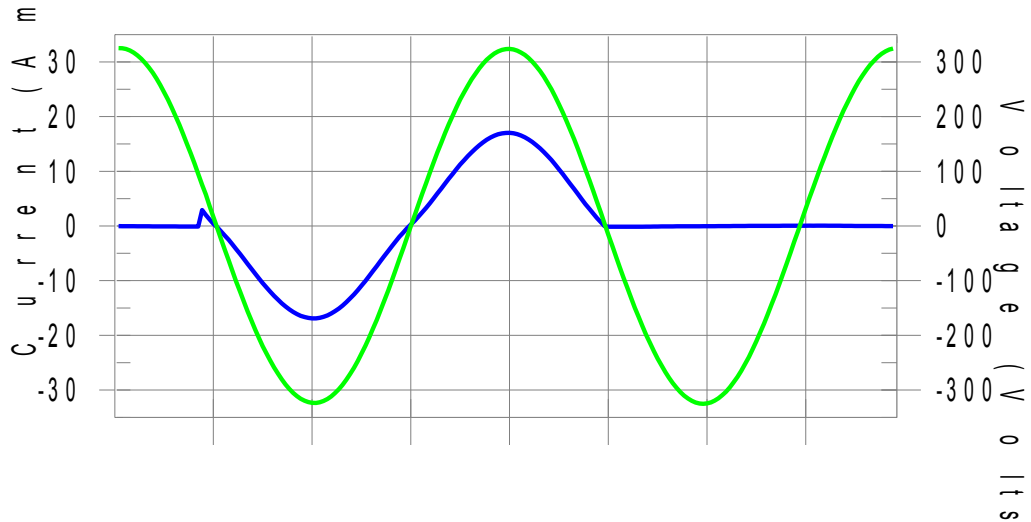

**Harmonics and Class A limit line      European Limits**

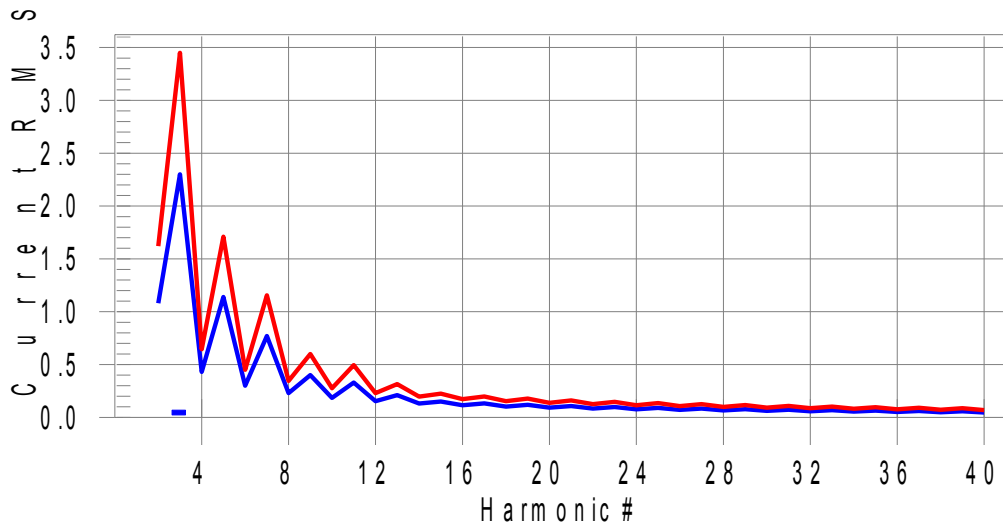

**Test result: Pass      Worst harmonic was #3 with 10.2% of the limit.**

---

Test Report No.: EFSH18052923-IE-02-E01

Eurofins Product Testing Service (Shanghai) Co., Ltd.  
No.395 West Jiangchang Road, Jing'an District, Shanghai, 200436, P.R. China

### Current Test Result Summary

Test Result: Pass      Source qualification: Normal  
 THC(A): 0.068    I-THD(%): 22.9    POHC(A): 0.000    POHC Limit(A): 0.251  
 Highest parameter values during test:

V_RMS (Volts):	230.17	Frequency(Hz):	50.00
I_Peak (Amps):	17.051	I_RMS (Amps):	8.031
I_Fund (Amps):	5.677	Crest Factor:	2.942
Power (Watts):	419.5	Power Factor:	0.964

Harm#	Harms(avg)	100%Limit	%of Limit	Harms(max)	150%Limit	%of Limit	Status
2	0.002	1.080	N/A	0.081	1.620	N/A	Pass
3	0.068	2.300	3.0	0.352	3.450	10.2	Pass
4	0.001	0.430	N/A	0.047	0.645	N/A	Pass
5	0.002	1.140	N/A	0.047	1.710	N/A	Pass
6	0.000	0.300	N/A	0.042	0.450	N/A	Pass
7	0.001	0.770	N/A	0.022	1.155	N/A	Pass
8	0.000	0.230	N/A	0.040	0.345	N/A	Pass
9	0.001	0.400	N/A	0.030	0.600	N/A	Pass
10	0.000	0.184	N/A	0.037	0.276	N/A	Pass
11	0.001	0.330	N/A	0.033	0.495	N/A	Pass
12	0.000	0.153	N/A	0.034	0.230	N/A	Pass
13	0.001	0.210	N/A	0.030	0.315	N/A	Pass
14	0.000	0.131	N/A	0.031	0.197	N/A	Pass
15	0.001	0.150	N/A	0.029	0.225	N/A	Pass
16	0.000	0.115	N/A	0.028	0.173	N/A	Pass
17	0.001	0.132	N/A	0.026	0.198	N/A	Pass
18	0.000	0.102	N/A	0.025	0.153	N/A	Pass
19	0.000	0.118	N/A	0.023	0.178	N/A	Pass
20	0.000	0.092	N/A	0.021	0.138	N/A	Pass
21	0.001	0.107	N/A	0.021	0.161	N/A	Pass
22	0.000	0.084	N/A	0.018	0.125	N/A	Pass
23	0.000	0.098	N/A	0.017	0.147	N/A	Pass
24	0.000	0.077	N/A	0.016	0.115	N/A	Pass
25	0.000	0.090	N/A	0.015	0.135	N/A	Pass
26	0.000	0.071	N/A	0.013	0.107	N/A	Pass
27	0.000	0.083	N/A	0.013	0.125	N/A	Pass
28	0.000	0.066	N/A	0.012	0.099	N/A	Pass
29	0.000	0.078	N/A	0.011	0.116	N/A	Pass
30	0.000	0.061	N/A	0.011	0.092	N/A	Pass
31	0.000	0.073	N/A	0.011	0.109	N/A	Pass
32	0.000	0.058	N/A	0.010	0.086	N/A	Pass
33	0.000	0.068	N/A	0.010	0.102	N/A	Pass
34	0.000	0.054	N/A	0.010	0.081	N/A	Pass
35	0.000	0.064	N/A	0.010	0.096	N/A	Pass
36	0.000	0.051	N/A	0.010	0.077	N/A	Pass
37	0.000	0.061	N/A	0.010	0.091	N/A	Pass
38	0.000	0.048	N/A	0.010	0.073	N/A	Pass
39	0.000	0.058	N/A	0.010	0.087	N/A	Pass
40	0.000	0.046	N/A	0.010	0.069	N/A	Pass

---

Test Report No.: EFSH18052923-IE-02-E01

Eurofins Product Testing Service (Shanghai) Co., Ltd.  
 No.395 West Jiangchang Road, Jing'an District, Shanghai, 200436, P.R. China

## 4.5 Voltage Changes, Voltage Fluctuations and Flicker

This part is concerned with the limitation of voltage fluctuations and flicker impressed on the public low-voltage system.

### 4.5.1 Limits

Value	Limit
Pst	1,0
Plt	0,65
dt	3,3%
dc	3,3%
dmax	4,0%

### 4.5.2 Measurement test procedure

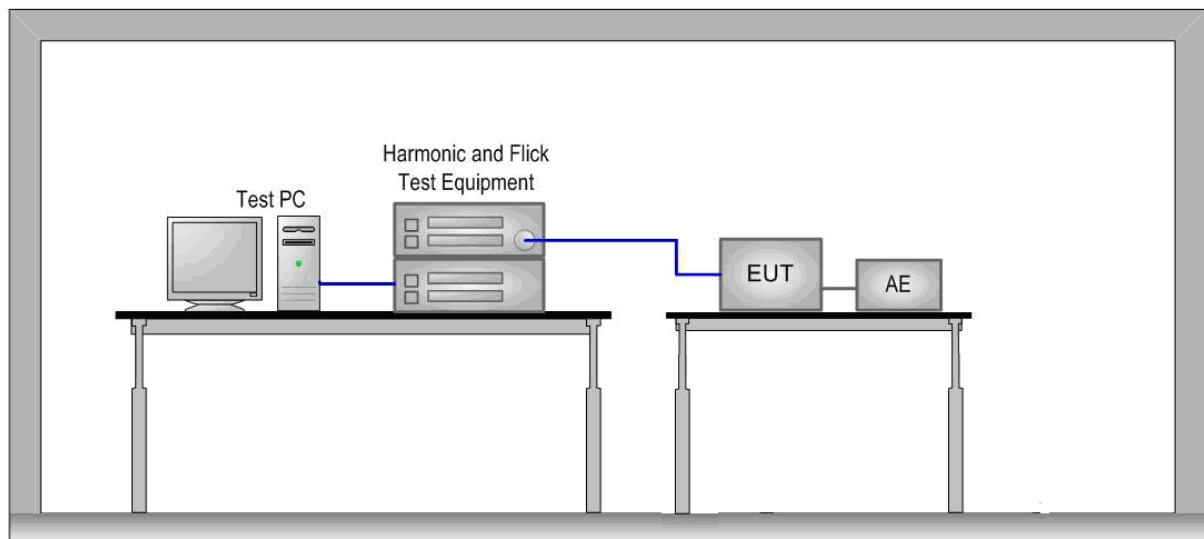

The equipment under test is placed on a wooden table with a height of 0,8 m in the EMC lab. The voltage fluctuations and flicker were measured at the supply terminals of the EUT.

### 4.5.3 Results

#### Model 1

Parameter values recorded during the test:

Vrms at the end of test (Volt):	230.10		
Highest dt (%):	0.00	Test limit (%):	N/A
T-max (mS):	0	Test limit (mS):	500.0
Highest dc (%):	0.00	Test limit (%):	3.30
Highest dmax (%):	0.14	Test limit (%):	4.00
Highest Pst (10 min. period):	0.064	Test limit:	1.000

Test Report No.: EFSH18052923-IE-02-E01

Eurofins Product Testing Service (Shanghai) Co., Ltd.  
No.395 West Jiangchang Road, Jing'an District, Shanghai, 200436, P.R. China



**Model 2**

**Parameter values recorded during the test:**

<b>Vrms at the end of test (Volt):</b>	<b>230.06</b>			
<b>Highest dt (%):</b>	<b>0.00</b>	<b>Test limit (%):</b>	<b>N/A</b>	<b>N/A</b>
<b>T-max (mS):</b>	<b>0</b>	<b>Test limit (mS):</b>	<b>500.0</b>	<b>Pass</b>
<b>Highest dc (%):</b>	<b>0.00</b>	<b>Test limit (%):</b>	<b>3.30</b>	<b>Pass</b>
<b>Highest dmax (%):</b>	<b>-0.12</b>	<b>Test limit (%):</b>	<b>4.00</b>	<b>Pass</b>
<b>Highest Pst (10 min. period):</b>	<b>0.064</b>	<b>Test limit:</b>	<b>1.000</b>	<b>Pass</b>

---

Test Report No.: EFSH18052923-IE-02-E01

---

Eurofins Product Testing Service (Shanghai) Co., Ltd.  
No.395 West Jiangchang Road, Jing'an District, Shanghai, 200436, P.R. China

## 5 Immunity Test

### 5.1 Performance Criteria Description in Clause 6 of EN 55014-2

<b>Criterion A:</b>	The apparatus shall continue to operate as intended during the test. No degradation of performance or loss of function is allowed below a performance level (or permissible loss of performance) specified by the manufacturer, when the apparatus is used as intended. If the minimum performance level or the permissible performance loss is not specified by the manufacturer, then either of these may be derived from the product description and documentation, and from what the user may reasonably expect from the apparatus if used as intended.
<b>Criterion B:</b>	The apparatus shall continue to operate as intended after the test. No degradation of performance or loss of function is allowed below a performance level (or permissible loss of performance) specified by the manufacturer, when the apparatus is used as intended. During the test, degradation of performance is allowed, however. No change of actual operating state or stored data is allowed. If the minimum performance level or the permissible performance loss is not specified by the manufacturer, then either of these may be derived from the product description and documentation and from what the user may reasonably expect from the apparatus if used as intended.
<b>Criterion C:</b>	Temporary loss of function is allowed, provided the function is self recoverable or can be restored by the operation of the controls, or by any operation specified in the instructions for use.

### 5.2 Classification of apparatus

<b>Category I:</b>	Apparatus containing no electronic control circuitry.
<b>Category II:</b>	Transformer toys, dual supply toys, mains powered motor operated appliances, tools, heating appliances and similar electric apparatus (for example . UV radiators, IR radiators and microwave ovens) containing electronic control circuitry with no internal clock frequency or oscillator frequency higher than 15 MHz.
<b>Category III:</b>	Equipment which in normal use, is not connected to a power network and has no cables attached. This category includes apparatus provided with rechargeable batteries, solar or other similar d.c. power sources which can be charged or operated by connecting the apparatus to the mains power. However, this apparatus shall also be tested as an apparatus in category II while it is connected to the mains network.
<b>Category IV:</b>	All other apparatus covered by the scope of this standard.

The EUT belongs to Category II.

---

Test Report No.: EFSH18052923-IE-02-E01

---

Eurofins Product Testing Service (Shanghai) Co., Ltd.  
No.395 West Jiangchang Road, Jing'an District, Shanghai, 200436, P.R. China

## 5.3 ESD

### 5.3.1 Test Procedures

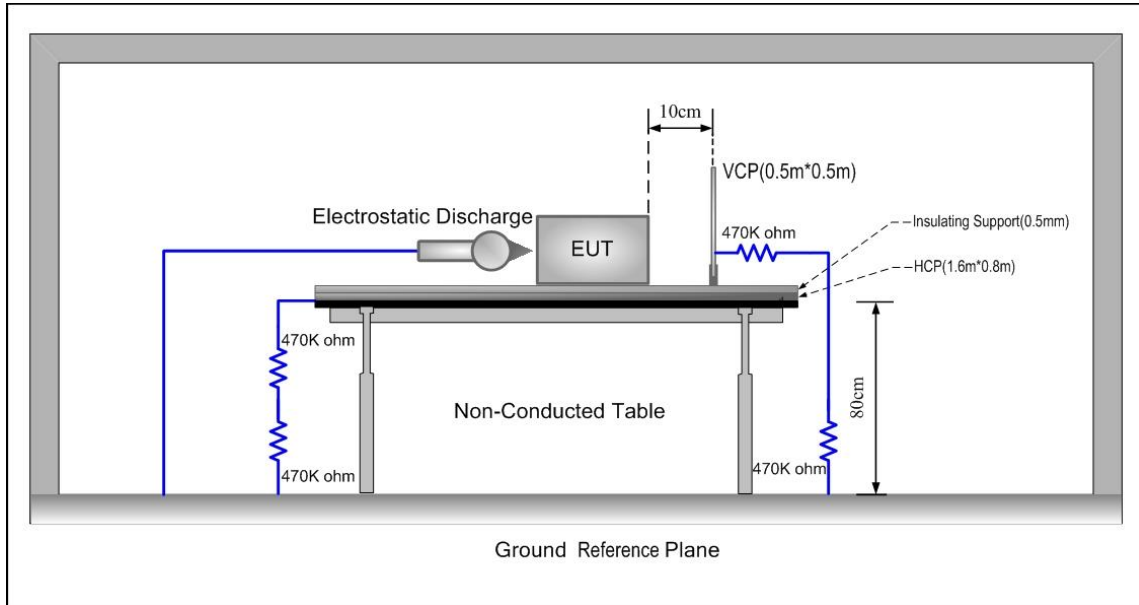

1. Contact discharge was applied only to conductive surfaces of the EUT. Air discharge was applied only to non-conducted surfaces of the EUT.
2. The EUT was put on a 0.8m high wooden table for table-top equipment or 0.1m high for floor standing equipment standing on the ground reference plane (GRP).
3. A horizontal coupling plane(HCP) 1.6m by 0.8m in size was placed on the table, and the EUT with its cables were isolated from the HCP by an insulating support thick than 0.5mm. The VCP 0.5m by 0.5m in size while HCP were constructed from the same material type and thickness as that of the GRP, and connected to the GRP via a 470kΩ resistor at each end. The distance between EUT and any of the other metallic surfaces excepted the GRP, HCP and VCP was greater than 1m.
4. During the contact discharges, the tip of the discharge electrode was touching the EUT before the discharge switch is operated. During the air discharges, the round discharge tip of the discharge electrode was approached as fast as possible to touch the EUT. After each discharge, the ESD generator was removed from the EUT, the generator is then retriggered for a new single discharge. For ungrounded product, a discharge cable with two resistances was used after each discharge to remove remnant electrostatic voltage. 10 times of each polarity single discharge were applied to HCP and VCP.

### 5.3.2 Results

Test point	Table (T) Floor (F)	Contact (C) Air (A)	Voltage (kV)	Number of discharge	Polarity (+ / -)	Opinion
Air discharge	T	A	8	20	+ / -	A
Contact discharge	T	C	4	20	+ / -	A
HCP	T	C	4	20	+ / -	A
VCP	T	C	4	20	+ / -	A

A: no loss of function.

Test Report No.: EFSH18052923-IE-02-E01

Eurofins Product Testing Service (Shanghai) Co., Ltd.  
No.395 West Jiangchang Road, Jing'an District, Shanghai, 200436, P.R. China

## 5.4 Electrical Fast Transients

### 5.4.1 Measurement procedure

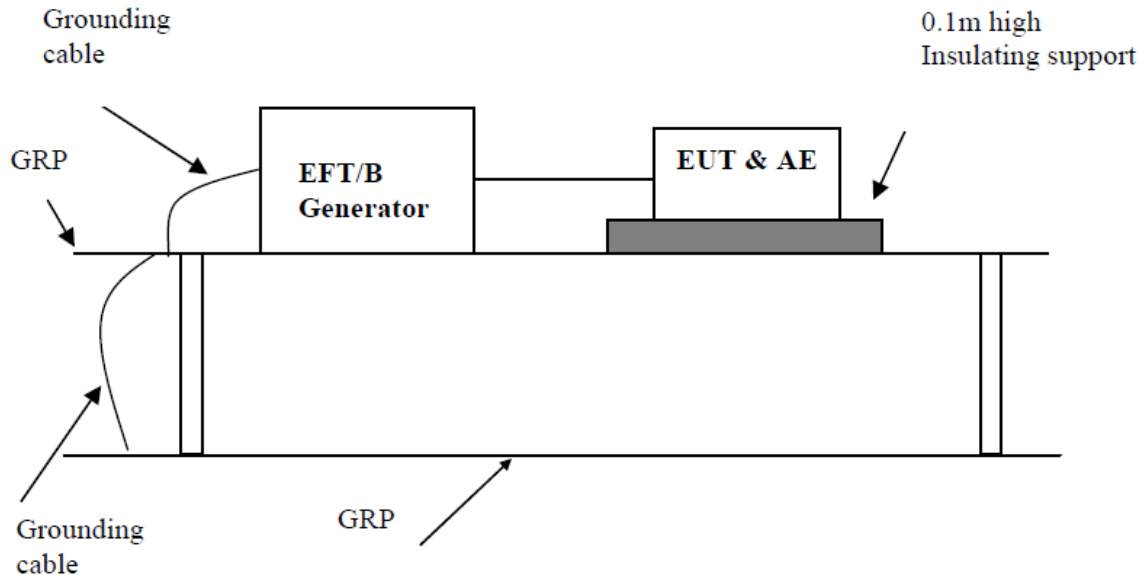

1. The EUT was placed on a ground reference plane (GRP) insulated by an insulating support 0.1 m thick and the GRP was placed on a 0.8m high wooden table for table-top equipment. For floor standing equipment, the EUT was placed on a 0.1m high wooden support above the GRP.
2. The GRP shall project beyond the EUT and the clamp by at least 0.1m on all sides. The distance between the EUT and any other of the metallic surface except the GRP was greater than 0.5m. All cables to the EUT was placed on the insulation support 0.1m above GRP. Cables not subject to EFT was routed as far as possible from cable under test to minimize the coupling between the cables.
3. The length of signal and power cable between the EUT and EFT generator was 0.5m. If the cable is a non-detachable supply cable more than 0.5m, the excess length of this cable shall be folded to avoid a flat coil and situated at a distance of 0.1m above the GRP.

### 5.4.2 Results

Test port	Voltage (kV)	Polarity (+ / -)	Duration (s or min)	Waveform Tr / Th	Repetition Frequency (kHz)	Opinion
AC power line	1	+	2 min	5/50 ns	5	A
AC power line	1	-	2 min	5/50 ns	5	A

A: no loss of function.

Test Report No.: EFSH18052923-IE-02-E01

Eurofins Product Testing Service (Shanghai) Co., Ltd.  
No.395 West Jiangchang Road, Jing'an District, Shanghai, 200436, P.R. China

## 5.5 Surge Immunity

### 5.5.1 Measurement procedure

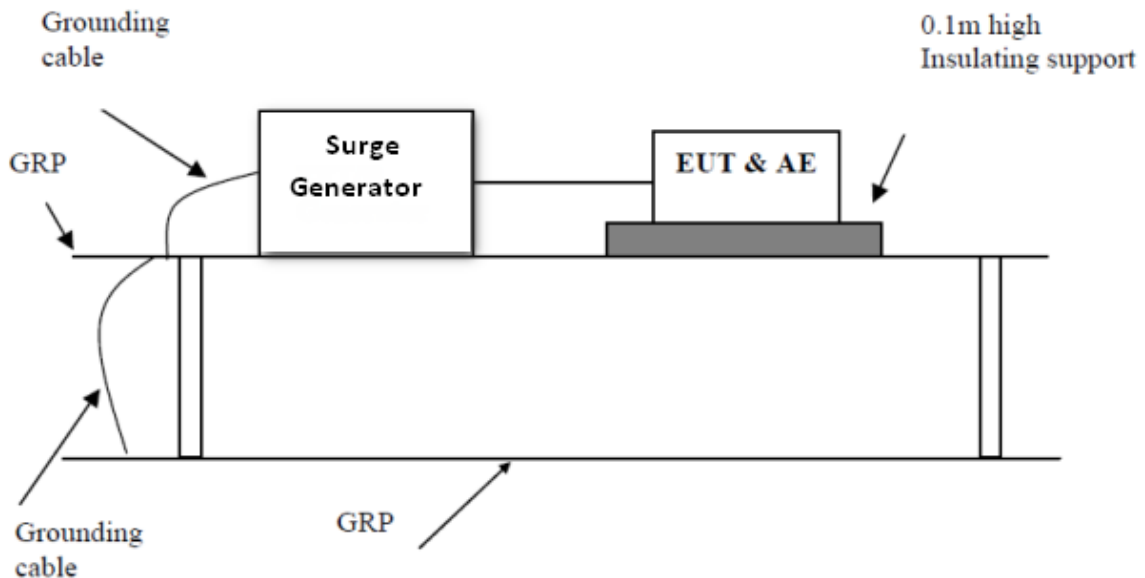

1. The EUT was placed on a ground reference plane (GRP) insulated by an insulating support 0,1 m thick and the GRP was placed on a 0.8m high wooden table for table-top equipment. For floor standing equipment, the EUT was placed on a 0.1m high wooden support above the GRP.
2. The 1,2/50  $\mu$ s surge was to be applied to the EUT power supply terminals via the capacitive coupling network. Decoupling networks were required in order to avoid possible adverse effects on equipment not under test that may be powered by the same lines and to provide sufficient decoupling impedance to the surge wave so that the specified wave may be applied on the lines under test.
3. The positive pulses are applied 90° relative to the phase angle of the a.c. line voltage to the equipment under test, and the negative pulses are applied 270° relative to the phase angle of the a.c. line voltage to the equipment under test.

### 5.5.2 Results

Test mode	Polarity (+ / -)	Voltage (kV)	Waveform Tr / Th	Number of pulses	Opinion
Line to line	+ / -	1	1.2/50 $\mu$ s	5	A

A: no loss of function.

Test Report No.: EFSH18052923-IE-02-E01

Eurofins Product Testing Service (Shanghai) Co., Ltd.  
No.395 West Jiangchang Road, Jing'an District, Shanghai, 200436, P.R. China

## 5.6 Injected currents(RF continues conducted)

### 5.6.1 Measurement procedure

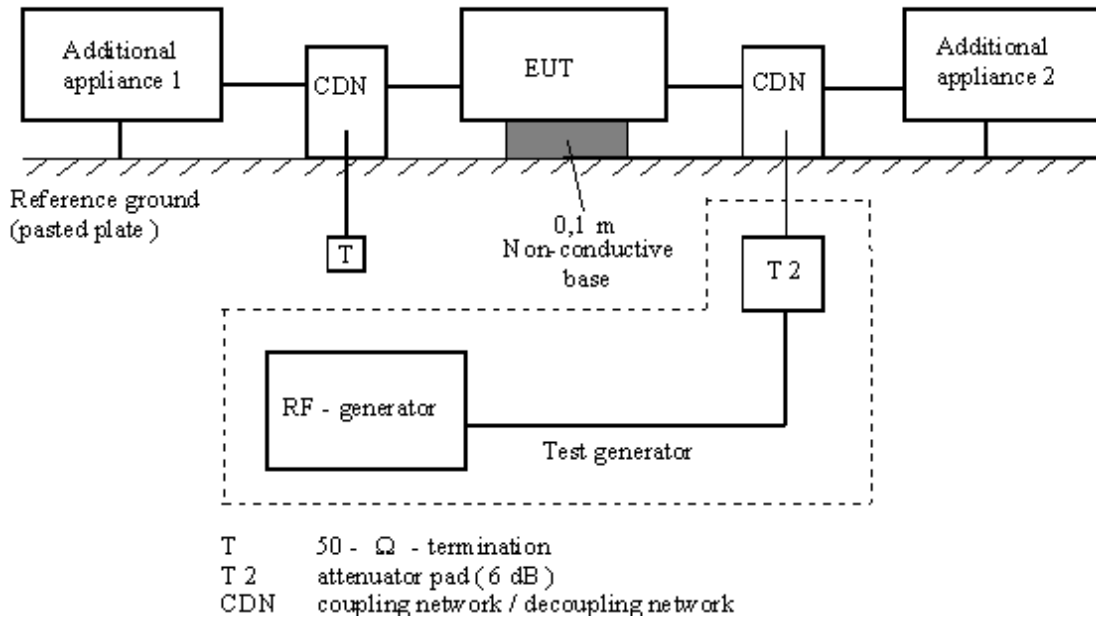

1. The EUT was placed on an insulating support of 0.1m height above a ground reference Plane, arranged and connected to satisfy its functional requirement. All cables exiting the EUT was supported at a height of at least 30 mm above the ground reference plane.
2. The coupling and decoupling devices were required, they were located between 0,1 m and 0,3 m from the EUT. This distance was to be measured horizontally from the projection of the EUT on to the ground reference plane to the coupling and decoupling device.
3. The frequency range was swept from 150 kHz to 230 MHz, using the signal levels established during the setting process, and with the disturbance signal 80 % amplitude modulated with a 1 kHz sine wave, pausing to adjust the RF signal level or to change coupling devices as necessary. Where the frequency was swept incrementally, the step size do not exceed 1 % of the preceding frequency value. The dwell time of the amplitude modulated carrier at each frequency was not less than the time necessary for the EUT to be exercised and to respond, and was not less than 3s.

### 5.6.2 Results

Test port	Voltage (e.m.f.)	Modulation	Frequency Range	Opinion
AC power port	3V	80% AM 1 kHz	150 kHz - 230 MHz	A

A: no loss of function.

Test Report No.: EFSH18052923-IE-02-E01

Eurofins Product Testing Service (Shanghai) Co., Ltd.  
No.395 West Jiangchang Road, Jing'an District, Shanghai, 200436, P.R. China

## 5.7 Voltage dips and Interruption

### 5.7.1 Measurement procedure

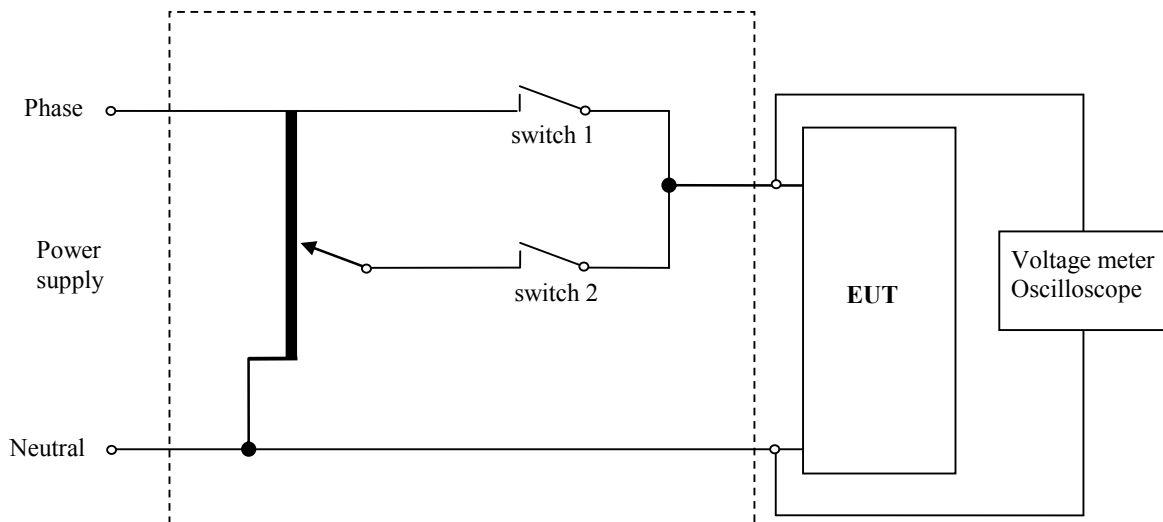

1. The EUT was placed on a ground reference plane (GRP) insulated by an insulating support 0,1 m thick and the GRP was placed on a 0.8m high wooden table for table-top equipment. For floor standing equipment, the EUT was placed on a 0.1m high wooden support above the GRP.
2. The test was performed with the EUT connected to the test generator with the shortest power supply cable as specified by the EUT manufacturer. Voltage change shall occur at zero crossing.
3. The EUT was tested for each selected combination of test level and duration with a sequence of three dips /interruptions with intervals of 10 s minimum. Each representative mode of operation was tested.

### 5.7.2 Results

Reduction of supply voltage of	Voltage in % (in V)	Duration in parts of period (in ms)	Opinion
interruption	0 % (0V)	0,5 (10 ms)	A
60 %	40 % (92 V)	10 (200 ms)	B
30 %	70 % (161 V)	25 (500 ms)	B

A: no loss of function.

B: the appliance could not work normally during the test, but it would recover after test.

Test Report No.: EFSH18052923-IE-02-E01

Eurofins Product Testing Service (Shanghai) Co., Ltd.  
No.395 West Jiangchang Road, Jing'an District, Shanghai, 200436, P.R. China

## 6 Test Setup Photos

Harmonic & Flicker



Conducted Emission



---

Test Report No.: EFSH18052923-IE-02-E01

Eurofins Product Testing Service (Shanghai) Co., Ltd.  
No.395 West Jiangchang Road, Jing'an District, Shanghai, 200436, P.R. China

Disturbance power



ESD



---

Test Report No.: EFSH18052923-IE-02-E01

Eurofins Product Testing Service (Shanghai) Co., Ltd.  
No.395 West Jiangchang Road, Jing'an District, Shanghai, 200436, P.R. China

Electrical Fast Transients, Surge & Dips



Injected currents (RF continues conducted)



---

Test Report No.: EFSH18052923-IE-02-E01

Eurofins Product Testing Service (Shanghai) Co., Ltd.  
No.395 West Jiangchang Road, Jing'an District, Shanghai, 200436, P.R. China

## 7 EUT Photos

Photo 1

Description: Overview of MK-708



Photo 2

Description: Bottom view of MK-708



---

Test Report No.: EFSH18052923-IE-02-E01

---

Eurofins Product Testing Service (Shanghai) Co., Ltd.  
No.395 West Jiangchang Road, Jing'an District, Shanghai, 200436, P.R. China

Photo 3  
Description: Front view of MK-708

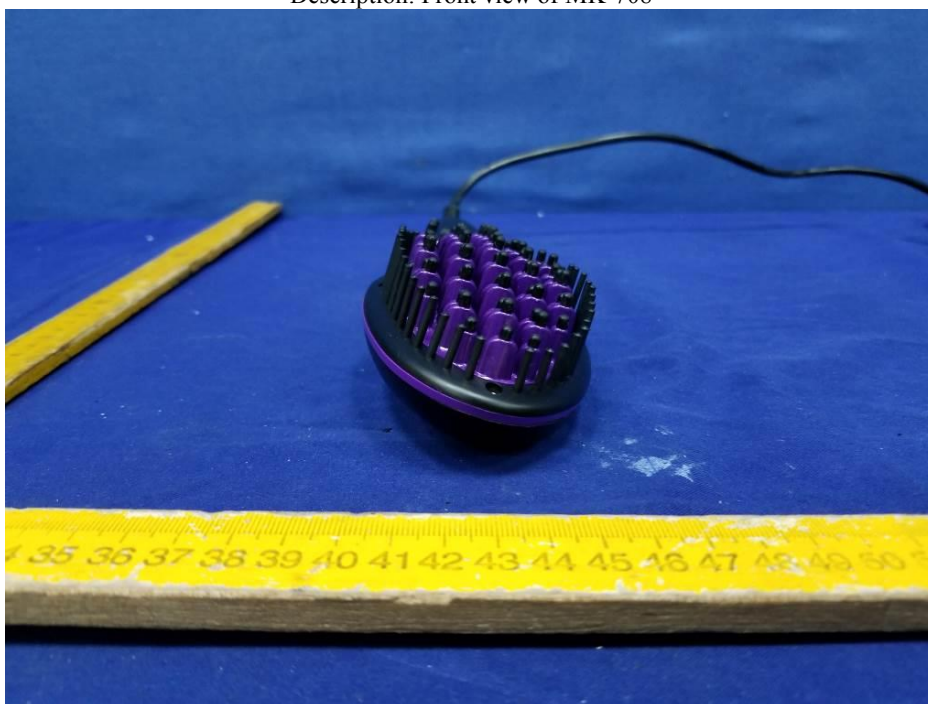
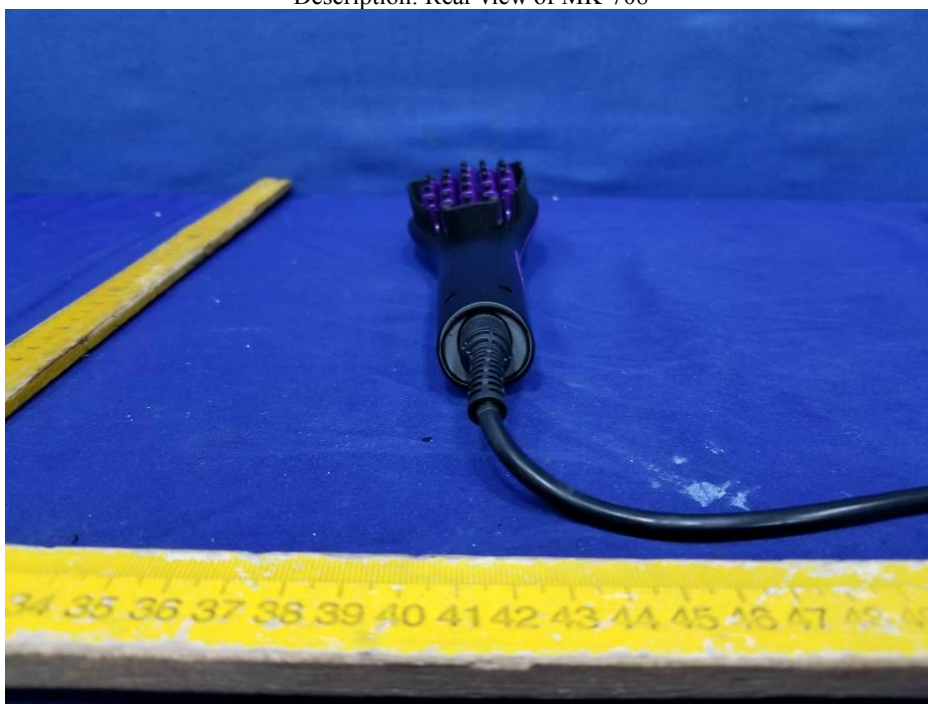

Photo 4  
Description: Rear view of MK-708



---

Test Report No.: EFSH18052923-IE-02-E01

Eurofins Product Testing Service (Shanghai) Co., Ltd.  
No.395 West Jiangchang Road, Jing'an District, Shanghai, 200436, P.R. China

Photo 5  
Description: Switch knob for MK-708



Photo 6  
Description: Internal view of MK-708



---

Test Report No.: EFSH18052923-IE-02-E01

Eurofins Product Testing Service (Shanghai) Co., Ltd.  
No.395 West Jiangchang Road, Jing'an District, Shanghai, 200436, P.R. China

Photo 7  
Description: PCB for MK-708

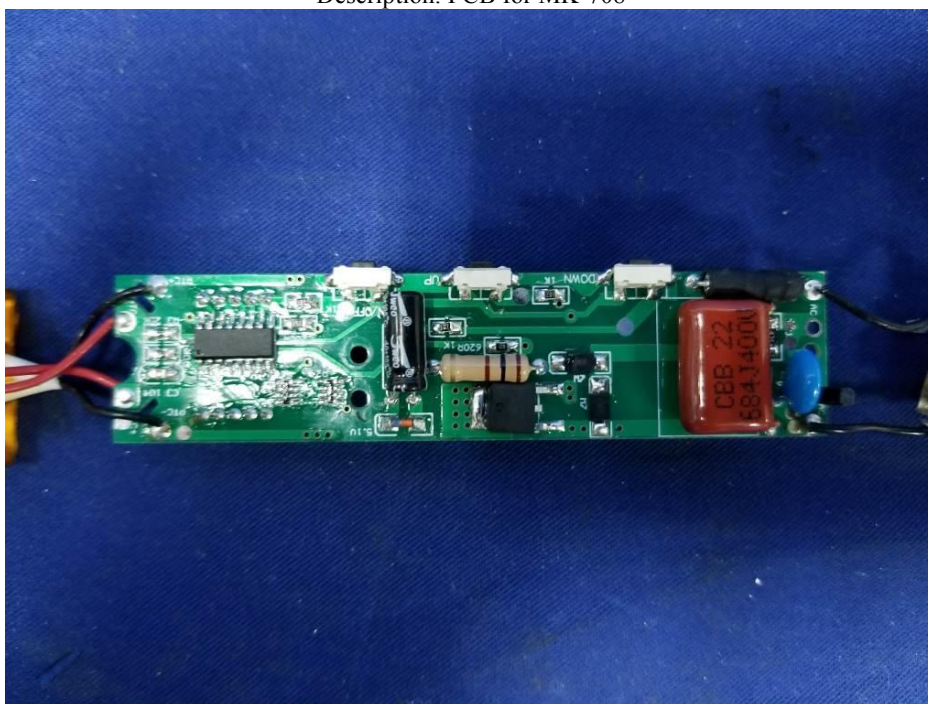
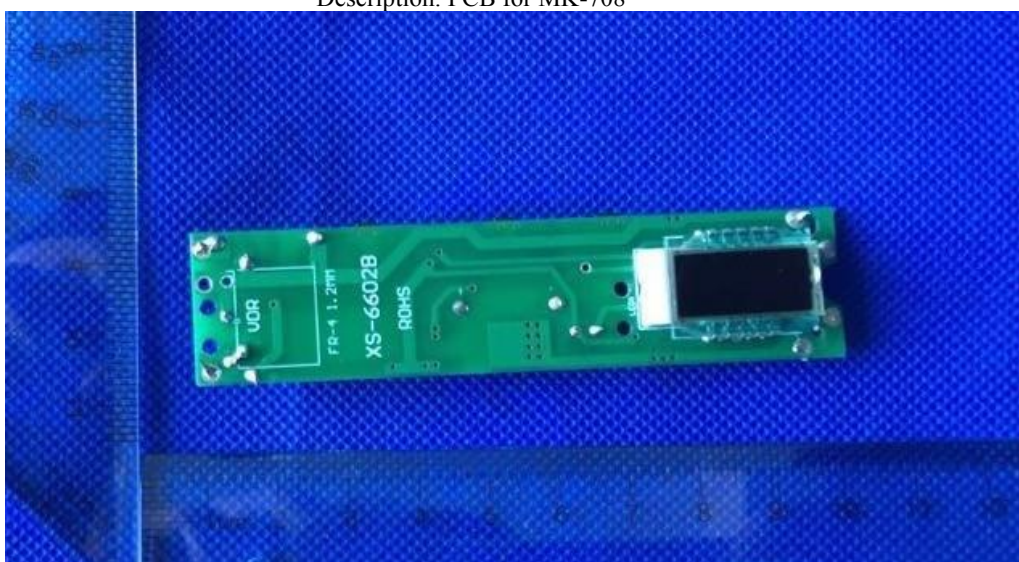

Photo 8  
Description: PCB for MK-708



---

Test Report No.: EFSH18052923-IE-02-E01

Eurofins Product Testing Service (Shanghai) Co., Ltd.  
No.395 West Jiangchang Road, Jing'an District, Shanghai, 200436, P.R. China

Photo 9

Description: PTC heating element and NTC sensor for MK-708



Photo 10

Description: PTC heating element and polyimide film for MK-708

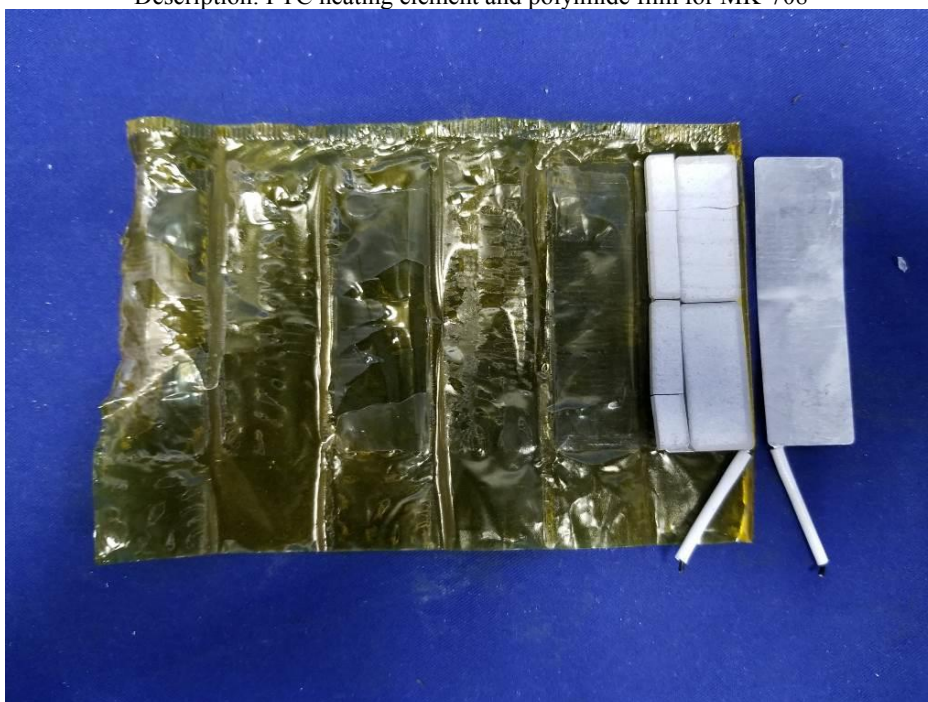

---

Test Report No.: EFSH18052923-IE-02-E01

Eurofins Product Testing Service (Shanghai) Co., Ltd.  
No.395 West Jiangchang Road, Jing'an District, Shanghai, 200436, P.R. China

Photo 11

Description: Swivel connector for MK-708

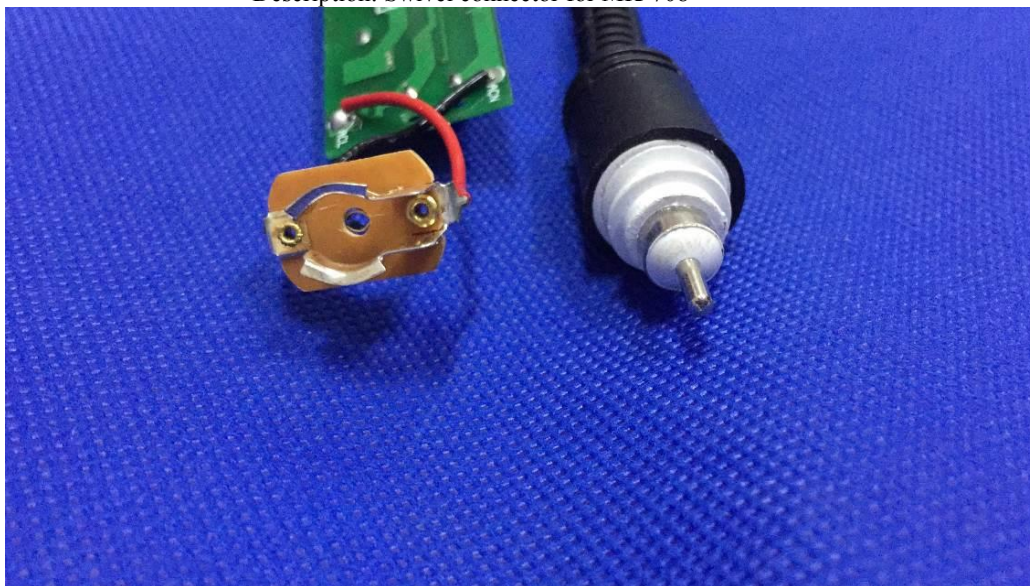

Photo 12

Description: Overview of MK-919



---

Test Report No.: EFSH18052923-IE-02-E01

Eurofins Product Testing Service (Shanghai) Co., Ltd.  
No.395 West Jiangchang Road, Jing'an District, Shanghai, 200436, P.R. China

Photo 13  
Description: Bottom view of MK-919



Photo 14  
Description: Front view of MK-919



---

Test Report No.: EFSH18052923-IE-02-E01

Eurofins Product Testing Service (Shanghai) Co., Ltd.  
No.395 West Jiangchang Road, Jing'an District, Shanghai, 200436, P.R. China

Photo 15  
Description: Rear view of MK-919

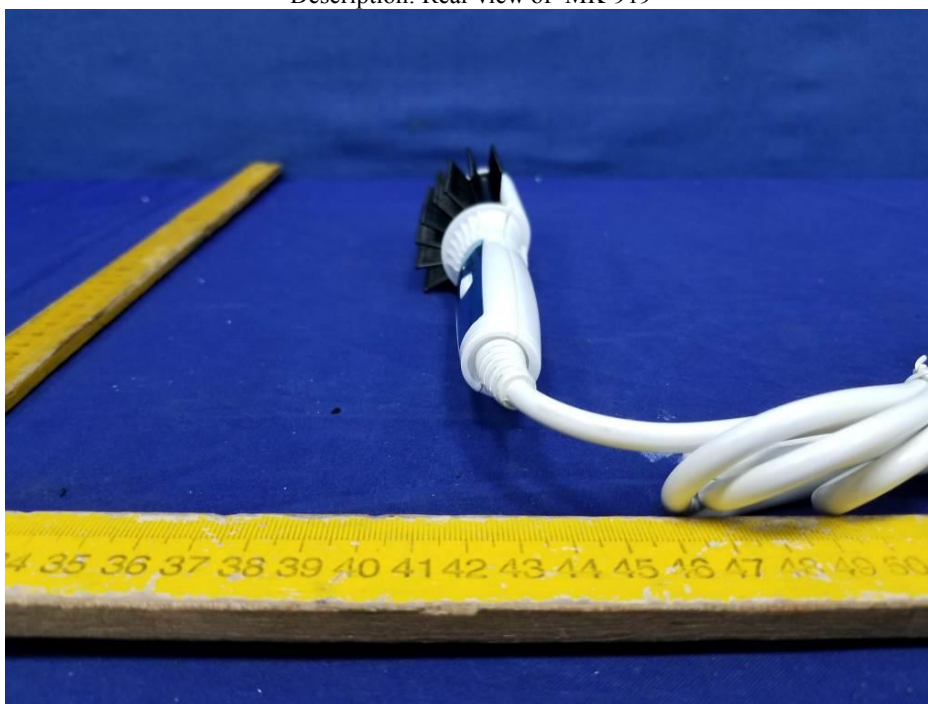

Photo 16  
Description: Switch knob for MK-919



---

Test Report No.: EFSH18052923-IE-02-E01

Eurofins Product Testing Service (Shanghai) Co., Ltd.  
No.395 West Jiangchang Road, Jing'an District, Shanghai, 200436, P.R. China

Photo 17  
Description: Internal view of MK-919



Photo 18  
Description: PCB for MK-919

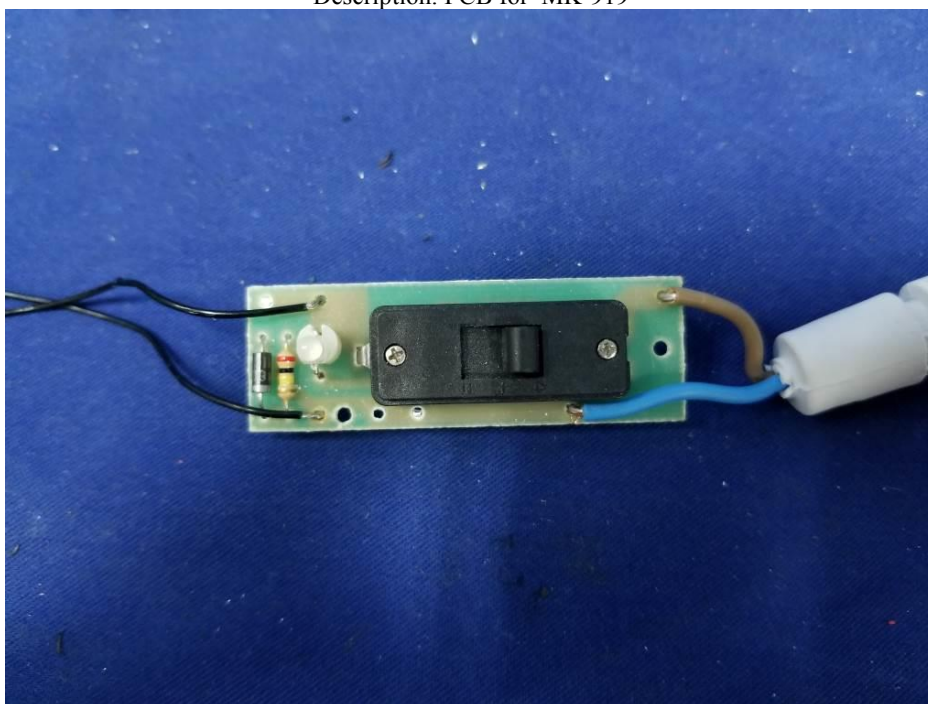

---

Test Report No.: EFSH18052923-IE-02-E01

Eurofins Product Testing Service (Shanghai) Co., Ltd.  
No.395 West Jiangchang Road, Jing'an District, Shanghai, 200436, P.R. China

Photo 19  
Description: PCB for MK-919

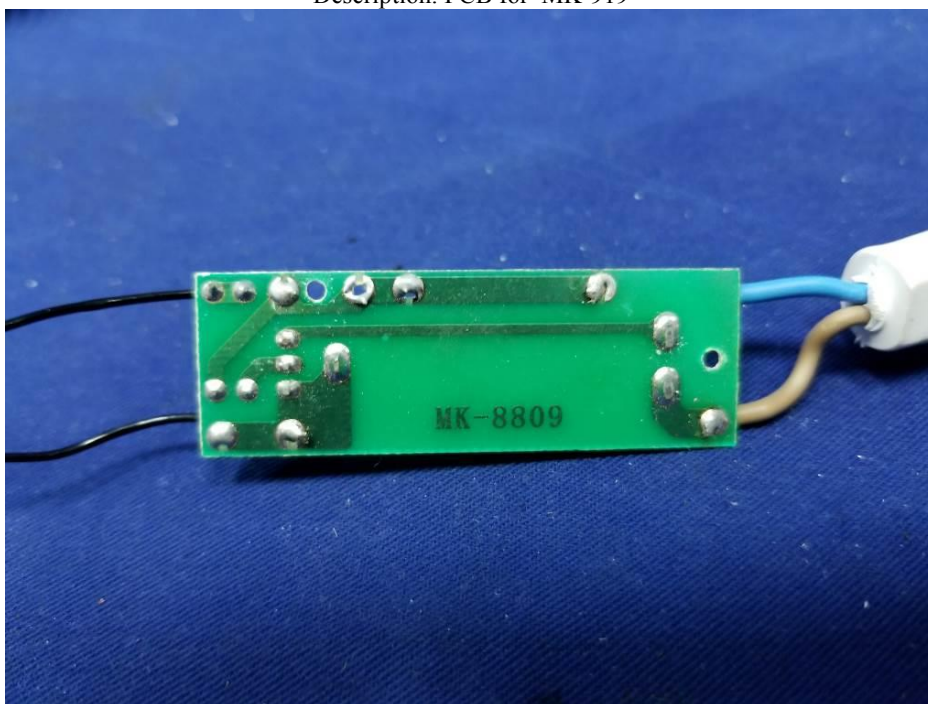

Photo 20  
Description: PTC heating element and polyimide film for MK-919



---

Test Report No.: EFSH18052923-IE-02-E01

Eurofins Product Testing Service (Shanghai) Co., Ltd.  
No.395 West Jiangchang Road, Jing'an District, Shanghai, 200436, P.R. China