

DUAL ELECTRIC AIR FRYER

Instruction manual



Dear consumer, please read these instructions carefully before use in order to avoid damage due to incorrect use and to better understand the functions of this product. Please pay particular attention to the safety guide. If you pass the device on to a third party, these Operating Instructions must also be handed over. Please keep them for future references.

IMPORTANT SAFEGUARDS

- ❑ Please read these instructions carefully before use.
- ❑ Keep present instructions for future references.
- ❑ Check that your mains voltage corresponds to that stated on the appliance.
- ❑ The device is intended for use in domestic and similar applications such as:
 - Kitchen work area in shops, offices, and other work environments.
 - Farms.
 - By customers of hotels, motels, and other residential environments.
 - Bed and breakfast type environments.
- ❑ Only use the appliance in the way indicated in these instructions.
- ❑ Never use this unit near bathtub, shower, wash-hand basins or other containers with water.
- ❑ Never use this apparatus near water projections.
- ❑ Never use this apparatus with the wet hands.
- ❑ If, unfortunately the apparatus is wet, immediately withdraw the cord of the socket-outlet.
- ❑ Inform potential users of these instructions.
- ❑ Never leave the appliance unsupervised when in use.
- ❑ The appliance must be used only for its intended purpose. No responsibility can be taken for any possible damage caused by incorrect use or improper handling.
- ❑ This appliance can be used by children aged from 8 years and above and persons with reduced physical, sensory or mental capabilities or lack of experience and knowledge if they have been given supervision or instruction concerning use of the appliance in a safe way and understand the hazards involved.
- ❑ Children shall not play with the appliance.

- ❑ Cleaning and user maintenance shall not be made by children unless they are older than 8 and supervised.
- ❑ Keep the appliance and its cord out of reach of children aged less than 8 years.
- ❑ In order to ensure your children's safety, please keep all packaging (plastic bags, boxes, polystyrene etc.) out of their reach.
- ❑ Caution! Do not allow small children to play with the foil :
THERE IS A DANGER OF SUFFOCATION!
- ❑ From time to time check the cord for damages. Never use the appliance if cord or appliance shows any signs of damage.
- ❑ Never immerse the appliance in water or any other liquid for any reason whatsoever.
- ❑ Never place it into the dishwasher.
- ❑ Never use the appliance near hot surfaces.
- ❑ Do not operate the appliance with a damaged cord or plug, or after the appliance has been damaged in any manner.
- ❑ If the supply cord is damaged, it must be replaced by the manufacturer, its service agent or similarly qualified persons in order to avoid a hazard.
- ❑ Disconnect the power source cable before any operation of cleaning of maintenance and accessories assembly.
- ❑ Never use the appliance outside and always place it in a dry environment.
- ❑ Never use accessories, which are not recommended by the producer. They could constitute a danger to the user and risk to damage the appliance.
- ❑ Never use any other connector than the one provided.
- ❑ Never move the appliance by pulling the cord. Make sure the cord cannot get caught in any way.
- ❑ Never wind the cord around the appliance and do not bend it.
- ❑ Ensure that the power cord does not come into contact with hot parts of this unit.

- Make sure the appliance has cooled down before cleaning and storing it.
- The temperature of accessible surfaces may be very high when the appliance is operating. Never touch these parts, of apparatus, to avoid burning itself.
- Make sure that hot parts of the appliance never comes into contact with flammable materials, such as curtains, cloth, fabrics, etc. while it is in operation, as a fire could break out.
- Make sure that the power cord and plug do not come in contact with water.
- Before cleaning, always unplug the appliance from the power supply and let it cool down. Take care that the hot parts of the appliance never come into contact with flammable materials, such as curtains, fabrics, etc. while it is in operation, as a fire could break out.
- This appliance is not intended to be operated by means of an external timer or separate remote-control system.
- Do not cover the device and do not to put anything on it.
- Always remove the plug from the wall socket when the appliance is not in use.
- When using an extension lead always make sure that the entire cable is unwound from the reel. Use solely CE approved extension leads. Input power must be at least 16A, 250V, 3000W.
- Incorrect operation and improper use can damage the appliance and cause injury to the user.
- This device, designed for home use, complies with standards relating to this type of product.
- The appliance must be used and rested on a table or flat & stable surface.
- The item must not be left unattended when it is connected to main supply.
- The item is not to be used, if it has been dropped or if there are visible signs of damage or if it is leaking.

- Regarding instructions for cleaning surfaces in contact with food or oil, thanks to refer to the below paragraph of the manual.
- This appliance is only intended for household use.

WARNING: RISK OF BURNS.

During operation, the surface temperature of the device can be very hot.

The heating parts remain hot long after stopping the machine.

GENERAL INFORMATION

The symbol "OPEN BOOK" means a recommendation to read important things contained in the record.



The symbol "BIN" crossed out, abbreviation WEEE (Waste of Electrical and Electronic Equipment) means that at the end of life, it should not be discarded with household waste, but filed to the sorting of the locality. Waste recovery can help preserve our environment.



The symbol "CE" is the guarantee of compliance with harmonized European standards, voluntary, reflecting the essential requirements into technical specifications. These standards are not mandatory but are guarantees of compliance with essential requirements.



The symbol ROHS (Restriction of use of some Hazardous Substances) on the Environmental Protection, certifies that for each of the five hazardous substances • Lead • Mercury • (hexavalent) chromium • products for protection against flames PBB and PBDE,



the peak concentration is equal to or less than 0.1% of the weight of homogeneous material, and 0.01% for the 6th • cadmium.

The symbol "HOT SURFACE" warns the user that the walls of the unit can become very hot, and to take precautions as required.

The symbol "GLASS / FORK" means that the device is compatible and can come into contact with foodstuffs.

The symbol "TRIMAN" indicates that the consumer is invited to dispose the product as part of a separate collection (eg recycling bin, waste, voluntary intake point).

The symbol "CMIM marking" is the guarantee of compliance with the harmonized Moroccan Standards, optional, which translate the essential requirements into technical specifications. These standards are not mandatory but guarantee compliance with the essential requirements.



FR
Cet appareil
et ses accessoires
se recyclent

À DÉPOSER
EN MAGASIN

À DÉPOSER
EN DÉCHÈTERIE

ou

Points de collecte sur www.quefairedemesdechets.fr
Privilégiez la réparation ou le don de votre appareil !

For more information : <http://www.quefairedemesdechets.fr>

CLEANING AND MAINTENANCE

- Before cleaning, always switch off the appliance, disconnect the apparatus and let it cool.
- Wait until the fryer is completely cool before starting cleaning.
Note : It is important to wait one or two hours after use to avoid any risk of burns.
- Remove remaining residues with paper towels before cleaning the device.
- Never plunge the apparatus or the control board in water or all other liquid!
- Clean the outside of the apparatus with a sponge or slightly wet linen.
- The parts (removable) in contact with food like plate, bowl, forks, Spatula etc. can be washed in hot water with sponge and soft detergent or put in the dishwasher.
- Do not use abrasive cleaners, gritting, or metal brush or another cutting object.
- Clean the inside of the appliance with hot water and a non-abrasive sponge.
- If dirt is stuck on the grid and/or the bottom of the drip pan, fill half of the drip pan with hot water and add a little washing-up liquid. Place the grid in the broiler pan and let the broiler pan and grid soak for about 10 minutes. Then clean with a damp, non-abrasive sponge, or a damp cloth.
- Clean the heating element (when cold) with a nylon cleaning brush to remove food residue.

Clean the appliance after every use.

The pot and the Shelf. Do not use metal kitchen utensils or abrasive cleaning materials to clean them, as this may damage the non-stick coating.

- 1 Remove the mains plug from the wall socket and let the appliance cool down.

Note: Remove the pot to let the Hot-air fryer cool down more quickly.

- 2 Wipe the outside of the appliance with a moist cloth.
- 3 Clean the pot and basket with hot water, some washing-up liquid and a non-abrasive sponge.

You can use degreasing liquid to remove any remaining dirt.

Tip: If dirt is stuck to the Shelf or the bottom of the pot, fill the pot with hot water with some washing-up liquid. Put the Shelf in the pot and let the pot and the Shelf soak for approximately 10 minutes.

- 4 Clean the inside of the appliance with hot water and non-abrasive sponge.
- 5 Clean the heating element with a cleaning brush to remove any food residues.

TO KNOW IT'S UNIT

FIG. 1 : Details of Air Fryer

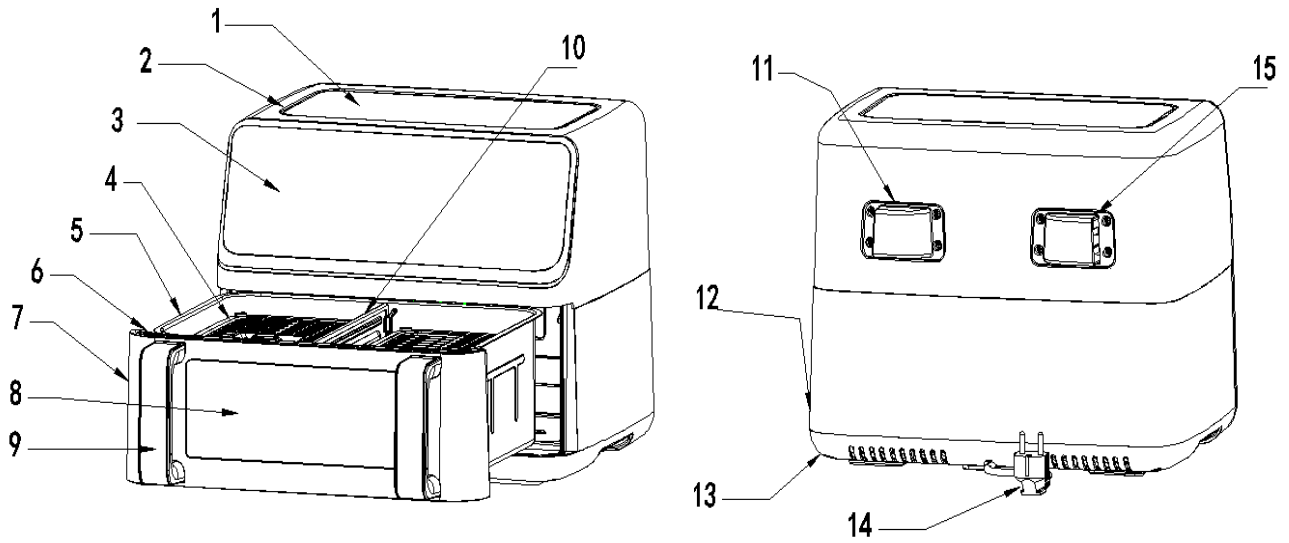

- 1 Top cover
- 2 Up Shell
- 3 Control panel
- 4 Base
- 5 Pot
- 6 Drawer
- 7 Front Drawer shell
- 8 Perspective window

- 9 Single pot handle
- 10 Bulkhead
- 11 Right air outlet
- 12 Down shell
- 13 Base
- 14 Main cord (Electrical cable)
- 15 Left air outlet Right drawer movement

FIG. 2+3+4+5 : Plug the electric socket on the wall plug

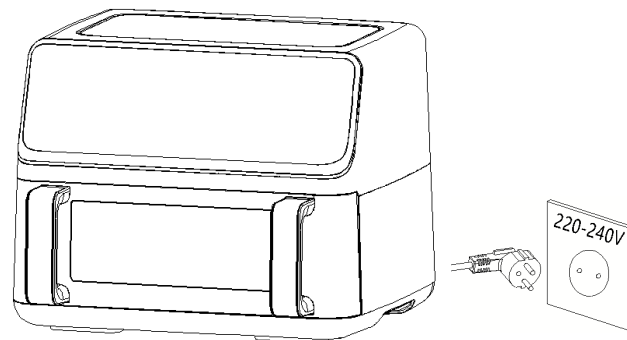

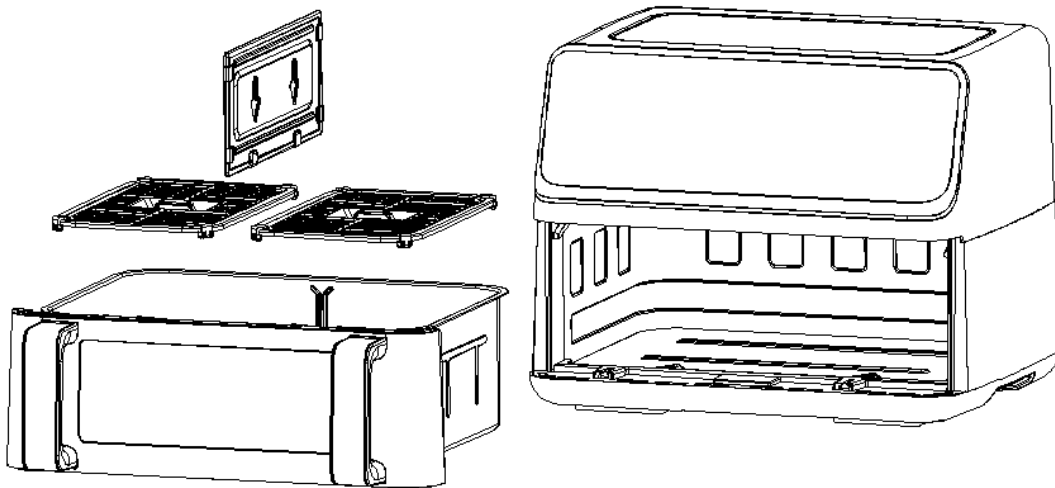

FIG. 6 Put the Food into the basket

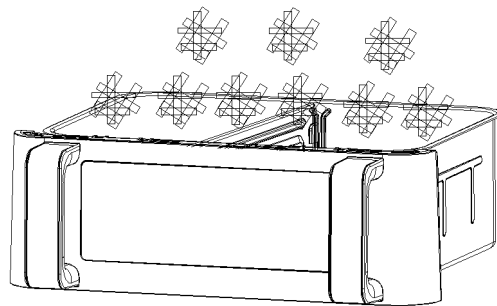
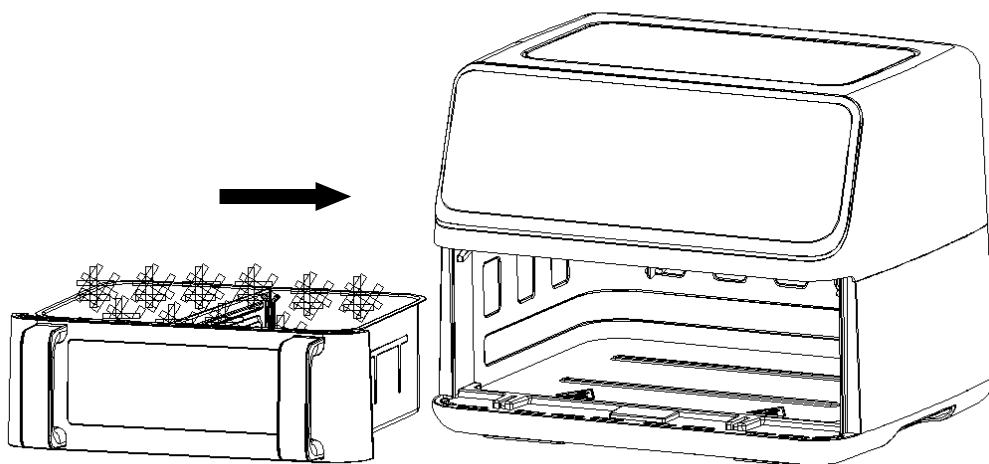

FIG. 7 : Put the baskets on the appliance



Important

Danger

- This appliance can be used by children aged from 8 years and above and persons with reduced physical, sensory or mental capabilities or lack of experience and knowledge if they have been given supervision or instruction concerning use of the appliance in a safe way and understand the hazards involved. Children shall not play with the appliance. Cleaning and user maintenance shall not be made by children unless they are older than 8 and supervised.
- Keep the appliance and its cord out of reach of children less than 8 years.
- Never immerse the housing, which contains electrical components and the heating elements, in water nor rinse it under the tap.
- Do not let any water or other liquid enter the appliance to prevent electric shock.
- Always put the ingredients to be fried in the basket, to prevent it from coming into contact with the heating elements.
- Do not cover the air inlet and the air outer openings while the appliance is operating.
- Do not fill the pot with oil as this may cause a fire hazard.
- Never touch the inside of the appliance while it is operating.
The temperature of accessible surfaces may be high when the appliance is operating

WARNING

- Check if the voltage indicated on the appliance fits the local mains voltage.
- Do not use the appliance if there is any damage on plug, mains cord or other parts.
- Do not go to any unauthorized person to replace or fix damaged main cord.
- Keep the mains cord away from hot surfaces.
- Do not plug in the appliance or operate the control panel with wet hands..
- Do not place the appliance against a wall or against other appliances. Leave at least 10cm free space on the back and sides and 10cm free space above the appliance.
Do not place anything on top of the appliance.
- Do not use the appliance for any other purpose than described in this manual.
- Do not let the appliance operate unattended.
- During hot air frying, hot steam is released through the air outlet openings, Keep your hands and face at a safe distance from the steam and from the air outlet openings. Also be careful of hot steam and air when you remove the pot from the appliance.
- Any accessible surfaces may become hot during use (Fig.2)
- Immediately unplug the appliance if you see dark smoke coming out of the appliance.
Wait for the smoke emission to stop before you remove the pot from the appliance.

Caution

- Ensure the appliance is placed on a horizontal, even and stable surface.
- This appliance is designed for household use only. It may not be suitable to be safely used in environments such as staff kitchens, farms, motels, and other non-residential environments. Nor is it intended to be used by clients in hotels, motels, bed and breakfasts and other residential environments.
- If the appliance is used improperly or for professional or semi-professional purposes or it is not used according to the instructions in the user manual, the guarantee becomes invalid and we could refuse any liability for damage caused.
- Always unplug the appliance while not using.
- The appliance needs approximately 30 minutes to cool down for handle or cleaning safely.

INTRODUCTION

This brand-new fryer design is an easy and healthy way to prepare your favourite dishes. By using the hot air circulation and a grill, it is possible to make many different dishes.

The special feature of this new fryer is to distribute the heat in all directions, so most ingredients heat up everywhere and do not need oil.

FIRST USE

1. Remove the device and all accessories from the packaging.
2. Remove all stickers and labels from the device, except for the rating label.
3. Clean Carefully the drip pan and the accessories with hot water and a little liquid detergent using a non-abrasive sponge or clean them following the instructions in the "CLEANING AND MAINTENANCE" paragraph.

Note : It is also possible to clean these parts in the dishwasher.

4. Wipe the inside and outside of the device with a damp cloth or towel.
5. Place the appliance on a stable, horizontal, and heat-resistant surface.
6. Place correctly the vegetable rack in the broiler pan.

Notes : Do not fill the pan with frying oil or fat because the device works with hot air. Never put anything on the device. This may damage control panel and affect the air frying result.

On first use, a slight smoke or odour may be emitted. This is normal and will disappear after a short time. However, He is essential to ensure that there is sufficient ventilation around the deep fryer.

PREPARING FOR USE

1. Place the appliance on a stable, horizontal and even surface.
Do not place the appliance on non-heat-resistant surface.
2. Place the basket in the pot (Fig.3).
Do not fill the pot with oil or any other liquid.
Do not put anything on top of the appliance, the airflow will be disrupted and affects the hot air frying result.

USING THE APPLIANCE

The oil-free can prepare a large range of ingredients.

Hot air frying

1. Connect the mains plug into an earthed wall socket.
2. Carefully pull the pot out of the Hot-air fryer (Fig.2+3+4+5).
Place the plates at the bottom of the basket and put the partition (Fig.2+3+4+5)
3. Put the ingredients in the basket. (Fig.2+3+4+5)
4. Slide the pot back into the Hot-air fryer (Fig 7) Noting to carefully align with the guides in the body of the fryer. **Never use the pot without the basket in it. Caution: Do not touch the pot during and some time after use, as it gets very hot. Only hold the pot by the handle.**

5. Determine the required preparation time for the ingredient (see section ‘Settings’ in this chapter).
6. Some ingredients require shaking halfway through the preparation time (see section “Settings” in this chapter). To shake the ingredients, pull the pot out of the appliance by the handle and shake it. Then slide the pot back into the air fryer
7. When you hear the timer buzzer, the set preparation time has elapsed. Pull the pot out of the appliance Note: Long press the power button for 2 seconds, then you can switch off the appliance manually.

Tip: You can adjust temperature or time according to your taste during use.

8. Check if the ingredients are ready.
If the ingredients are not ready yet, simply slide the pot back into the appliance and set the timer to a few extra minutes.
9. To remove ingredients (e.g. fries), pull the pot out of the Hot-air fryer and place it on trial framework.
Do not turn the basket upside down , as any excess oil that has collected on the bottom of the pot will leak onto the ingredients.

The pot and the ingredients are hot. Depending on the type of the ingredients in the air fryer, steam may escape from the pot.
10. Use clips or tools to transfer food to a plate.
11. When a batch of ingredients is ready, the Hot-air fryer is instantly ready for preparing another batch.

CONTROL PANEL INSTRUCTION

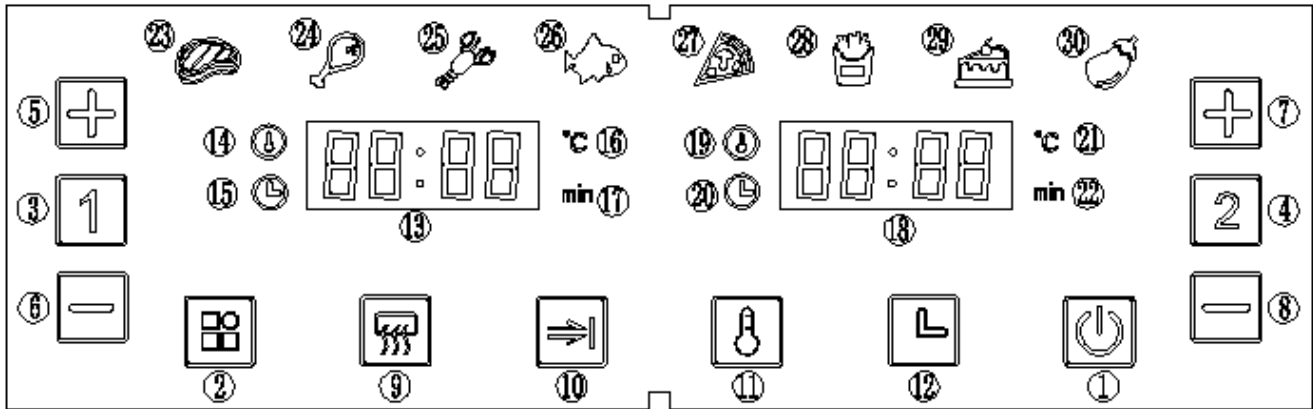

KEY 1 - Power key





Once the Basket and pot are properly placed in the main housing, the Power light will be illuminated. Select the power key to put the machine into standby mode, After selecting the pot body to be used, Selecting the Power key a second time will start the cooking process. Pressing the power key for 2 seconds to close the entire device during cooking, synchronous stop of motor.

Note: During cooking, you can touch the keys to control the pause and start of cooking.





KEY 2 - Preset Key

Selecting the “” Preset key enables you to scroll through the 8 popular food choices (23-30). Once selected, the predetermined time and cooking temperature function begins.

KEY 3 - The left pot Key



Touch the “” key, The icon of the function key of the pot body on the left will light up, the menu defaults to the first menu (fries), at this time the fries indicator flashes,  pot corresponding digital tube display flashes, and alternately display the default temperature and time of the fries program. When the temperature is displayed, the temperature indicator on the upper left of the display are always on. When the time is displayed, the time indicator on the lower left of the display will be always on. If you press the  key for 2 seconds, you can cancel the selection of  pot and the product enters standby mode.

KEY 4 - The Right pot Key

Touch the “”key, The icon of the function key of the pot body on the Right will light up, the menu defaults to the first menu (Steak), at this time the steak indicator flashes,  pot corresponding digital tube display flashes, and alternately display the default temperature and time of the steak program. When the temperature is displayed, the temperature indicator on the upper left of the display are always on. When the time is displayed, the time indicator on the lower left of the display will be always on. If you press the  key for 2 seconds, you can cancel the selection of  pot and the product enters standby mode.

KEY 5  & **KEY 6**  - Temperature and Timer Control Keys For The left pot Key

The Key 5 and Key 6 symbols enable you to add or decrease cooking temperature 5°C at a time for left pot. Keeping the Key held down will rapidly change the temperature. Temperature Control range: 80°C - 200°C. Also can to add or decrease cooking time for left pot, one minute at a time. Keeping the key held down will rapidly change the time. Temperature Control range: 1min-60min.

KEY 7  & **KEY 8**  - Temperature and Timer Control Keys For The right pot Key

The Key 7 and Key 8 symbols enable you to add or decrease cooking temperature 5°C at a time for right pot. Keeping the Key held down will rapidly change the temperature. Temperature Control range: 80°C - 200°C. Also can to add or decrease cooking time for right pot, one minute at a time. Keeping the key held down will rapidly change the time. Temperature Control range: 1min-60min.

KEY 9  - Preheat key Icon

Select “” or “” ,Touch the “”key, then and press””again to start the device; Preheat function default 160 degrees, 3 minutes.

KEY 10  - Synchronization end key

Touch the “”key, two recipe with different time can be ended at the same time.

Key 11  -The temperature of key.

Key 12  -The time of key.

Indicator light “13 ” Nixie tube for the left pot body

Indicator light “14 ” Temperature light for the left pot body

Indicator light “15 ” Timer light for the left pot body

Indicator light “16 ” Temperature unit indicator light for the left pot body

Indicator light “17 ”Time unit indicator light for the left pot body

Indicator light “18 ” Nixie tube for the right pot body

Indicator light “19 ” Temperature light for the right pot body

Indicator light “20 ” Timer light for the right pot body

Indicator light “21 ” Temperature unit indicator light for the right pot body

Indicator light “22 ”Time unit indicator light for the right pot body



Indicator light “ 23-30 ” Recipe indicator

Detailed Operation Instructions





1. Boot mode

Firstly to confirm that the frying pan is correctly installed into the machine, insert the plug into the socket, the machine will be powered on, the machine will beep once, all the lights are lit for one second and then extinguished, the Power Icon will be illuminated.



2. Standby Mode

Touch the Power Icon, and the Pot 1 Selection Icon  and Pot 2 Select Icon  indicator lights up and stays on, the product enters standby mode. When the unit is in this Standby mode and has not been operated within 5 mins, unit will be goes to Boot mode.



3. Single pot working mode(Bulkhead)

3.1、 Touching the icon  or , then the indicator of function , menu are lit and always on, the indicator of steak flashing as the defaults menu is steak, and the others indicator always on; Meanwhile the indicator of temperature and time flashing; If pressing and hold the icon  for 2 sec, it can cancel the selection for the left pot, and icon  for right pot. If two pots are be cancel by pressing the icons then the product enters Standby mode.

3.2、 Touching the Menu Choice Key Icon, that is to select the menu you need to use, according to the actual situation of food to adjust the temperature and time if you need; When adjusting temperature, every time you press, the temperature changes by 5°C, long press "+" or "-" key, the temperature will increase or decrease continuously. For each menu, the temperature adjustable range of 80°C - 200°C; Time adjustment: every time you press, the time changes by 1min, the time adjustable range of 1min -60min.

3.3、 After the debugging to recipe, temperature and time are all complete, touch the Power Key Icon, the pot icon icon  / , starts working, and the display shows the current cooking time in count down manner, stop flashing. The selected recipe indicator is steady on, other recipe indicators are off;

3.4、 If need to adjust the temperature or time during the cooking process, pressing the Temp or Time Key  Icon once, then pressing "+" or "-" Key Icon to adjust the Temp or Time. During the adjustment process, the machine keeps working.

3.5、 If need to reset the recipe during cooking process, it is needed to lightly press  / , and lightly press the Power Key Icon,the heater stop working,the motor continues to work for 20 seconds and then stops,meanwhile the indicator of recipe and display screen flashing, then adjust the recipe as required, and at this time can also adjust the temperature and time.

3.6、 Lightly press the "" during cooking, the heater stop working,the motor continues to work for 20 seconds and then stops,. If there is no operation, the machine will automatically return to standby mode after 5 minutes.

3.7、 If need to turn off the machine during cooking, press the "power key " for 2 seconds and the machine will be turned off. the heater stop working,the motor continues to work for 20 seconds and then stops. At this time, the display screen will display the word "OFF", and the buzzer will beep.



3.8、 After the cooking, the screen displays the word "OFF", and the buzzer gives a prompt sound of "beep" 5 times. The display screen is display off and the machine returns to standby mode.



3.9、 During the cooking, take out the frying basket, the display screen will show the words "OPEN", the machine stops working, after inserting the frying basket, the machine resumes its previous work;



4. Double pot working mode (Bulkhead)

4.1 Starting the 2 pots

4.1.1、 Firstly, select one side and debug the menu, temperature and time according to needs. Secondly, select another side and debug the wanted recipe, temperature and time in the same way.

4.1.2、 Pressing the Power Key Icon , 2 pots start working at the same time,  key and indicator light of Pot1 recipe flashes once per 6 seconds at the same time,  key and indicator light of Pot2 recipe flashes once per 6 seconds at the same time, Pot1 and Pot2 display alternately, about 3 seconds interval;



4.1.3、 It also can be started left Pot firstly by press “Power key  and then press  to set parameter of right Pot, after right Pot ready , press “Power key 

4.1.4、 During the double pots working process, pressing the Temp  or Time Key Icon  once, the recipe of temperature will be displayed alternately in left and right display screen, 3 seconds after no operation will switch to time display;

4.2 Debug during the double pots working process



4.2.1、 During the cooking process of left and right pots are working at the same time, if you need to debug the temp or time for left Pot, press  and then debug the temp and time as you need, the recipe can't be debug in this state. If no operation within 10 seconds after debugging, the display screen automatically returns to normal;

4.2.2、 If you need to debug the temperature or time of right Pot, refer to 4.2.1;

4.2.3、 During the cooking process, recipe and temp/time can be adjusted by press / and “Power key 

4.2.4、 After the machine enter the pause mode, if there is no operation after 5 minutes, the suspended Pot will enter the standby mode.

4.3 Close Left pot or right pot



4.3.1、 Press the  key or  pot first, and then long press the "power key" for 2 seconds, the selected pot will stop working and return to standby mode.

4.4 Draw out of the basket





4.4.1、 Firstly, select one side and debug the menu, temperature and time according to needs. Secondly, select another side and debug the wanted recipe, temperature and time in the same way.



4.4.2、 When the frying basket is drawn out in standby state, the display will show the "OPEN". At this time, the corresponding pot cannot be operated.

4.5 Pausing the 2 pots

4.5.1、 When double-pot cooking, press "power key  once, and the left Pot and right Pot enter the pause mode at the same time, and the two screens and recipes are flashing. Press the "Power key  again, and the left Pot and right Pot resumes working mode;

4.5.2、 When left Pot and right Pot are paused at the same time, if there are no operation within 5 minutes. After 5 minutes, both pots will stop working and return to standby mode;



4.5.3、 During left Pot and right Pot cooking, gently press the "power key  once, the left Pot and right Pot enter the pause mode at the same time, if you need to adjust, first press the  or , and then adjust the recipe, temperature and time according to your needs; After debugging, press the "Power key  once to resume to work the left Pot and right Pot at the same time;

4.5.4、 During left Pot and right Pot cooking, gently press "Power key  once, the left Pot and right Pot will enter the pause mode at the same time, long press the "Power key  again for 2 seconds, left Pot and right Pot will stop working at the same time, the left and right screens will display "OFF", and the product will return to the standby mode after a prompt sound of "beep".

4.6 Stop the 2 pots



4.6.1、 During left pot and right pot cooking, long press the "Power key" for 2 seconds, left pot and right pot will stop working at the same time, and the left and right screens will display "OFF". After a prompt sound of "beep", the machine will enter the standby mode.

4.6.2、 There is no operation in the simultaneous cooking left pot and right pot, after the display time ends, both heating and motor will be stopped, and the display screen displays "OFF". After the buzzer gives out 5 prompt sounds of "beep", the display screen is off and the machine returns to the standby mode;

4.6.3、 If you want to turn off one pot of the left Pot or right Pot cooking, press  or  first, and then long press the "Power key  for 2 seconds. The selected pot will stop working, and the corresponding display screen will display "OFF". After a prompt sound of "Beep", it will return to standby mode. At this point, the machine state changes to single pot working mode.

4.7 Simultaneous end function

4.7.1、 This function will be waked up only when two recipes with different time are selected in left pot and right pot mode and the indicator light will be lit at the same time. The awakened state is flashing display.



4.7.2、 After selecting the menu, press "Synchronous end key"  firstly, it become a normally on, press the "Power key" again, the machine began to work, at this point, the long time menu pot to work, short time pot of the screen shows "HOLD", when the extra time has passed, the short time pot began to work, "synchronization end key "  keep normally on in this process;

4.7.3、 During the working, if the time displayed on one pot of the HOLD is set to greater than that the other side, exit the synchronization end mode, and the "synchronization end button" indicator is off.

4.7.4、 During the working, pull out the pot, the time will be suspended, the screen shows "OPEN", insert a pot, continue to synchronize work;





4.7.5、 During the synchronous operation, if one pot of the left pot and right pot is suspended and the other pot continues to work, exit the synchronization end function and the "Synchronization end key" indicator is off;

5. None Bulkhead MODE

5.1、 When the food is large enough, do not use the middle partition, select , select the menu, then select , select the same menu, press the power button to start the machine for baking. For details, see Double pot working mode (Bulkhead).

5.2、 Do not use the middle partition mode to bake the whole chicken, choose any menu in the left pan and the right pan at the same time, adjust the temperature in the menu to 200 degrees Celsius, set the time to 45 minutes, press the power button to turn on the left and right heaters at the same time for baking.

Remark Items

1. Boot mode: When in this mode, only the Power Key Icon is illuminated;
2. Standby mode: the Power Key Icon and left Pot and right Pot Key Icon are all illuminated;
3. Debug the unit when unit is not working: the corresponding function key is always on, the selected recipe indicator is flashing, the rest of the menu indicator is always on, the corresponding display is flashing alternately to show the temperature/time of the selected recipe. When adjusting the menu, the selected recipe is flashing, when debugging the temperature, press the temperature key, the display is flashing to show the current temperature, press the time key to adjust the time, the display switches the current time and flashes to show. When the left Pot and right Pot Key is in the selected state at the same time, the side that is not selected, the corresponding menu does not flash, the corresponding display alternately shows the temperature and time without flashing, in this this process heaters and motors are not work;
4. Debugging mode during cooking process: the recipe does not flash. The screen flashes to display the temp and time. You can adjust the temp and time, but the recipe cannot be adjust;
5. Single pot pause mode: the corresponding function key is steady on, and the menu indicator blinks when selected. The other menu indicators are steady on, and the corresponding display screen blinks, indicating temperature/time. The corresponding  or  key blinks, and the menu, temperature and time can be adjusted at this time;
6. Left Pot and right Pot Key pause mode: the corresponding function key is steady on, the selected menu indicator blinks, the other menu indicator is steady on, the display screen blinks, showing the temperature/time, corresponding  and  key blink;
7. Working mode: the corresponding function key is steady on, the selected menu indicator is steady on, other menu indicators are off, and the corresponding screen displays the menu time;
8. When the left Pot and right Pot Key are working at the same time, the key indicator and the corresponding menu indicator of the  pot blink at the same time /6 seconds, and the extinguishing time < 0.5 seconds. After 3 seconds, the key indicator and the

corresponding menu indicator of the pot blink at the same time /6 seconds, and the extinguishing time < 0.5 seconds, and the left and right blink alternately, and the left and right interval time is 3 seconds;

9. Memory function: this machine has memory function, when the cooking is finished, the machine does not power off, in the next use, select the same pot body with the last time, will directly display the menu used last time; The memory function will disappear when the machine is powered off for 1 hour. After more than 1 hour, the initial state will be displayed when the machine is powered on again;
10. Power off memory: if the machine is in use, if the power is cut off accidentally, as long as it is re-energized within 30 minutes, the machine will return to the working state before power off;
11. Display failure mode:
 - 11.1 E1 is displayed: The NTC is Opened.
 - 11.2 E2 is displayed: The NTC is Short Circuit.

Settings

This table below will help you to select the basic settings for the ingredients.

Note: Keep in mind that these settings are indications. As ingredients differ in origin, size, shape as well as brand, we cannot guarantee the best setting for your ingredients.

Because the Rapid Air technology instantly reheats the air inside the appliance instantly Pull the **pot** briefly out of the appliance during hot air frying barely disturbs the process.

Tips

- *Smaller ingredients usually require a slightly shorter preparation time than larger ingredients.*
- *A larger amount of ingredients only requires a slightly longer preparation time, a smaller amount of ingredients only requires a slightly shorter preparation time.*
- *Shaking smaller ingredients halfway through the preparation time optimizes the end result and can help prevent unevenly fried ingredients.*
- *Add some oil to fresh potatoes for a crispy result. Fry your ingredients in the Hot-air fryer within a few minutes after you added the oil.*
- *Do not prepare extremely greasy ingredients such as sausages in the Hot-air fryer .*
- *Snacks that can be prepared in a oven can also be prepared in the Hot-air fryer*
- *The optimal amount for preparing crispy fries is 500 grams.*
- *Use pre-made dough to prepare filled snacks quickly and easily. Pre-made dough also requires a shorter preparation time than home-made dough.*
- *Place a baking tin or oven dish in the Hot-air fryer basket if you want to bake a cake or quiche or if you want to fry fragile ingredients or filled ingredients*
- *You can also use the Hot-air fryer to reheat ingredients. To reheat ingredients, set the temperature to 150°C for up to 10 minutes.*

menu	Reference weight	Default temperature	Default pot time	temperature range	time frame	Shake
Steak	400	200°C	15min	80-200°C	1-60min	1-2
Chicken wings	600	200°C	30min	80-200°C	1-60min	1-2
Shrimp	600	190°C	10min	80-200°C	1-60min	1-2
Fish	500	180°C	25min	80-200°C	1-60min	1-2
Pizza	400	180°C	10min	80-200°C	1-60min	--
Fries	450	200°C	25min	80-200°C	1-60min	1-2
Bake	400	180°C	12min	80-200° C	1-60min	--
Vegetables	300	170°C	20min	80-200°C	1-60min	1-2

Note1: Add 3 minutes to the preparation time when you start frying while the Hot-air fryer is still cold.

Note2: You can adjust the temperature or time according to the actual cooking effect when using two cooking pots at the same time.

Attention !!!

Do not touch the outer surface of the appliance for at least 30 minutes after use, as it becomes very hot. Risk of burns.
Hold drawers only by their handles.

USE

1. Plug the mains plug into a wall socket (earthed).
2. Put the ingredients in the drawer(s).
3. Place the griddle(s) in the correct position.

Choose a program from the menu and press "Start/Pause" to start cooking.

4. On-screen display

The display will show the temperature and time. The temperature is the one set and the countdown displayed, is the remaining cooking time.

Note: The logo of the selected function or program flashes.

5. Shake the ingredients

Some ingredients should be shaken halfway of the cooking time.

To do this, pull the drawer out of the appliance by the handle, shake it gently and put it back in the fryer. See also the "Settings" paragraph in this manual.

6. Timer

When the timer rings, the set cooking time has elapsed.

Remove the drawer from the unit and place it on a heat resistant surface.

7. Check if the ingredients are ready.

If the ingredients are not cooked enough, simply put the drawer back in the appliance and cook for a few more minutes.

8. Empty the tray

Pour the cooked ingredients into a bowl or onto a plate.

Tip: To remove bulky or fragile ingredients, use a pair of tongs to lift the ingredients off the tray.

9. When the current cooking is complete, the air fryer is instantly ready to cook other ingredients.

STORAGE

- Ensure the unit is completely cool and dry.
- Do not wrap the cord around the appliance, as this will cause damage.
- Keep the appliance in a cool, dry place and out of reach from children.

SoTech Techwood General Warranty Conditions

- Regarding the return with packaging section, we will replace the existing sentence with "If returning a defective device, we recommend sending it in its original packaging or in well-protected packaging to avoid any damage."

Before delivery, all our products undergo a rigorous inspection.

This device is guaranteed for 24 months (parts and labor) from the date of purchase by the consumer.

Warranty proof includes:

- the invoice and/or receipt with the device model and date of purchase.

Without this proof, no free replacement or repair can be performed.

During the warranty period, we will repair or replace any defects in the device or accessories, free of charge, resulting from a material or manufacturing defect.

- Any repair or exchange will automatically extend the warranty by 6 months.

In the event of recourse to the To return the product under warranty, return the complete device to your retailer along with proof of purchase.

- If returning a defective device, we recommend sending it in its original packaging or in well-protected packaging to avoid damage.

- The warranty does not apply to fragile parts made of glass, ceramic, plastic, etc., unless their failure is attributable to a manufacturing or design defect.

Wearing parts (e.g., motor carbon brushes, hooks, drive belts, replacement remote controls, replacement toothbrushes, saw blades, etc.) and their cleaning, maintenance, or replacement are not covered by the warranty and are therefore your responsibility.

In the event of third-party intervention, the warranty becomes void.

After the warranty period has expired, repairs can be carried out, for a fee, by a specialist retailer or a repair service.

Electrical schematic diagram

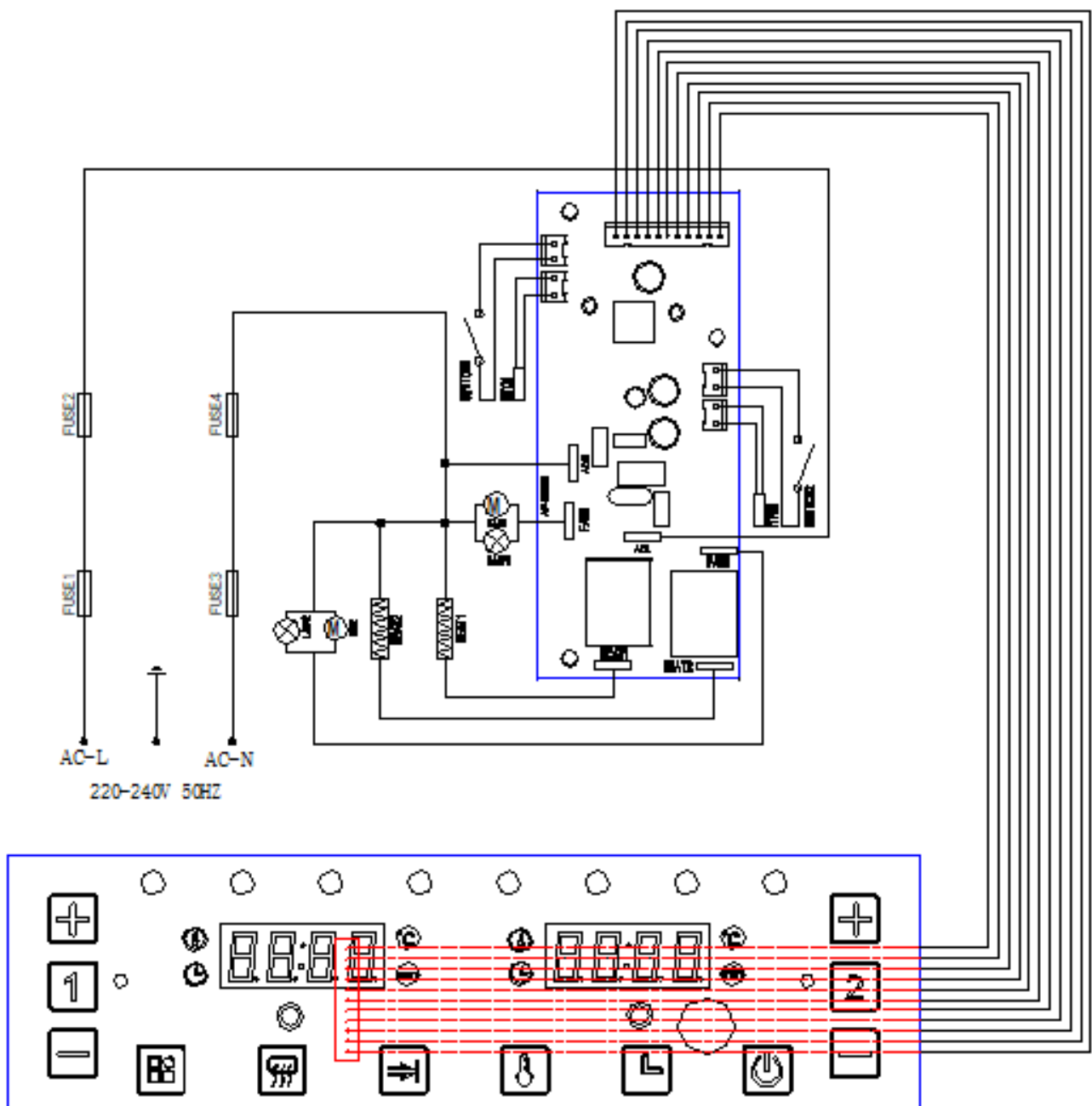

Troubleshooting

problem	Possible cause	Solution
The Hot-air fryer does not work	The appliance is not plugged in.	Put the mains plug in an earthed wall socket.
The ingredients fried with the air fryer are not done.	The amount of ingredients in the basket is too big.	Put smaller batches of ingredients in the basket. Smaller batches are fried more evenly.
	The set temperature is too low.	Set the temperature key to the required temperature setting (see section 'settings' in chapter 'Using the appliance').
	The preparation time is too short.	Set the timer to the required preparation time (see section 'Settings' in chapter 'Using the appliance').
The ingredients are fried unevenly in the air fryer.	Certain types of ingredients need to be shaken halfway through the preparation time.	Ingredients that lie on top of or across each other (e.g. fries) need to be shaken halfway through the preparation time. See section 'Settings' in chapter 'Using the appliance'.
Fried snacks are not crispy when they come out of the air fryer.	You used a type of snacks meant to be prepared in a traditional deep fryer.	Use oven snacks or lightly brush some oil onto the snacks for a crispier result.
I cannot slide the pan into the appliance properly.	There are too much ingredients in the basket.	Do not fill the basket beyond the MAX indication.
	The basket is not placed in the pot correctly.	Push the basket down into the pot until you hear a click.
White smoke comes out of the appliance.	You are preparing greasy ingredients.	When you fry greasy ingredients in the air fryer, a large amount of oil will leak into the pot. The oil produces white smoke and the pot may heat up more than usual. This does not affect the appliance or the end result.
	The pot still contains grease residues from previous use.	White smoke is caused by grease heating up in the pan . make sure you clean the pan properly after each use.
Fresh fries are fried unevenly in the air fryer.	You did not use the right potato type.	Use fresh potatoes and make sure they stay firm during frying.
	You did not rinse the potato sticks properly before you fried them.	Rinse the potato sticks properly to remove starch from the outside of the sticks.
Fresh fries are not crispy when they come out of the air fryer.	The crispiness of the fries depends on the amount of oil and water in the fries.	Make sure you dry the potato sticks properly before you add the oil.
		Cut the potato sticks smaller for a crispier result.
		Add slightly more oil for a crispier result.

SPECIFICATIONS

Power supply	220-240V~ 50-60Hz
Power	2700W
Norm	Class I
Adjustable temperature	80°C - 200°C
Timer	0 to 60 min
Capacity	4,5L + 4,5L = 9,00L

Standby mode consumption: 0.27W

NOTE: This product immediately switches to standby mode when cooking is complete.

Made in P.R.C

The characteristics can change without prior notice

This unit is equipped with an electrical outlet with earth and must be earthed in an according plug.

Note : In the event of question concerning the earth or electric connection, please consult a qualified personnel.

In the event of short-circuit, earthing reduces the risk of electric shock while making possible the current to be evacuated by the wire of ground.

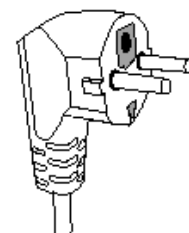

CAUTION: In order to minimize the risks of electric shock, In the event of breakdown, not to open the case but to call upon a qualified technician for repairs.

This device complies with EC directives, it was controlled according to all current European directives, applicable such as: electromagnetic compatibility (EMC) and low voltage (LVD).

This device has been designed and manufactured in compliance with the latest regulations and technical requirements for safety.

NOVEMBER 2024

Air Fry Cooking Chart

INGREDIENT	AMOUNT PER ZONE	PREPARATION
VEGETABLES		
Asparagus	1 bunch	Whole, stems trimmed
Beets	6-7 small	Whole
Bell peppers (for roasting)	3 small peppers	Whole
Broccoli	1 head	Cut in 1-inch florets
Brussels sprouts	1 lb	Cut in half, stem removed
Brussels squash	1 1/2lbs	Cut in 1-2-inch pieces
Carrots	1 lb	Peeled, cut in 1/2-inch pieces
Cauliflower	1 head	Cut in 1-inch florets
Corn on the cob	2 ears, cut in half	Husks removed
Green beans	1 bag (12oz)	Trimmed
Kale(for chips)	5 cups, packed	Torn in pieces, stem removed
Mushrooms	8 oz	Rinsed, cut in quarters
Potatoes, russet	1 1/2 lbs 1 lb 1 lb 3 whole (6-8oz)	Cut in 1-inch wedges Hand-cut fries*, thin Hand-cut fries*, thick Pierced with fork 3 times
Potatoes, sweet	1 1/2 lbs 3 whole (6-8oz)	Cut in 1-inch chunks Pierced with fork 3 times
Zucchini	1 lb	Cut in quarters lengthwise, then cut in 1-inch pieces
POULTRY		
Chicken breasts	2 breasts 4 breasts	Bone in Boneless
Chicken thighs	2 thighs 4 thighs	Bone in Boneless
Chicken wings	2 lbs	Drumettes & flats
FISH&SEAFOOD		
Crab cakes	2 cakes (6-8 oz each)	None
Lobster tails	4 tails (3-4 oz each)	Whole
Salmon fillets	3 fillets (4 oz each)	None
Shrimp	1 lb	Whole,peeled,tails on

INGREDIENT	AMOUNT PER ZONE	PREPARATION
BEEF		
Burgers	2 quarter-pound patties,80% lean	1/2 inch thick
Steaks	2 steaks (8 oz each)	Whole
PORK		
Bacon	3 strips,cut in half	None
Pork chops	2 thick-cut,bone-in chops (10-12 oz each) 2 boneless chops (8 oz each)	Bone in Boneless
Pork tenderloins	1 lb	None
Sausages	5 sausaged	None

FROZEN FOODS

Chicken cutlets	3 cutlets	None
Chicken nuggets	1 box (12 oz)	None
Fish fillets	1 box (6 fillets)	None
Fish sticks	18 fish sticks (11 oz)	None
French fries	1 lb	None
French fries	1 lbs	None
Mozzarella sticks	1 box (11 oz)	None
Pot stickers	2 bags (10.5 oz)	None
Pizza rolls	1 bag (20 oz,40 count)	None
Popcorn shrimp	1 box (14-16 oz)	None
Sweet potato fries	1 lb	None
Tater tots	1 lb	None
Onion Rings	10 oz	None

Dehydrate Chart

INGREDIENT	PREPARATION	TEMPERATURE (°C)	SINGLE ZONE DUALZONE
FRUITES&VEGETABLES			
Apples	Cored, cut in 1/8-inch slices, rinsed in lemon water, patted dry	60	7-8 hours
Asparagus	Cut in 1-inch pieces, blanched	60	6-8 hours
Bananas	Peeled, cut in 3/8-inch slices	60	8-10 hours
Beets	Peeled, cut in 1/8-inch slices	60	6-8 hours
Eggplant	Peeled, cut in 1/4-inch slices, blanched	60	6-8 hours
Fresh herbs	Rinsed, patted dry, stems removed	60	4 hours
Ginger root	cut in 3/8-inch slices	60	6 hours
Mangoes	Peeled, cut in 3/8-inch slices, pit removed	60	6-8 hours
Mushrooms	Cleaned with soft brush (do not wash)	60	6-8 hours
Pineapple	Peeled, cut in 3/8-1/2-inch slices	60	6-8 hours
Strawberries	Cut in half or in 1/2-inch slices	60	6-8 hours
Tomatoes	Cut in 3/8-inch slices or grated; steam if planning to rehydrate	60	6-8 hours
MEAT, POULTRY, FISH			
Beef jerky	Cut in 1/4-inch slices, marinated overnight	70	5-7 hours
Chicken jerky	Cut in 1/4-inch slices, marinated overnight	70	5-7 hours
Turkey jerky	Cut in 1/4-inch slices, marinated overnight	70	5-7 hours
Salmon jerky	Cut in 1/4-inch slices, marinated overnight	70	3-5 hours

RECIPES



Asian Spicy French Fries

-Potato	4 pcs / 600g
-Oil	2 teaspoons
-Salt	1 teaspoon
-Pepper powder	1 teaspoon
-Scallion powder	1 teaspoon
-Chili pepper powder	1/2 teaspoon
-Garlic powder	1/2 teaspoon

Peel the potatoes and cut into strips.

Dip the strips of potato in salted water for at least 20 minutes, then dry with paper towels.

Mix well shallot, salt, pepper, garlic powder, oil and chilli powder.

Stir in the potato strips into the mixture.

Set the temperature to 180° and the timer to 5 minutes for preheating.

Place the strips of potato in the frying basket.

Put the drawer in the appliance and set the timer for 15-20 minutes (depending on the size of the fries) or until the fries turn golden brown.

Note : Shake the basket in the middle of the cooking process to return the fries and obtain a better cooking result.



Golden chicken wings

-Chicken wings	500g
-AGarlic	2 cloves
-Powdered Ginger	2 teaspoons
- Ground cumin	1 teaspoon
-Powdered pepper	1 teaspoon
-Spicy sauce	100 mg
-Salt	1 teaspoon

Set the temperature to 200 and the timer to 5 minutes for preheating.

Mix garlic, ginger powder, ground cumin, black pepper, hot pepper sauce and salt.

Coat chicken wings with this mixture.

Let macerate for 20 minutes.

Place evenly the chicken wings in the frying basket.

Put the drawer in the appliance and set the timer for 15-20 minutes or until become golden brown.



Fried chicken nuggets

-Fresh chicken fillet	500g
-Eggs	3 pcs
-Wheat flour	1 cup
-Olive oil	1 tablespoon
-Powdered white powder	1 teaspoon
-Salt	1 pinch

Set the temperature to 200 and the timer to 5 minutes for preheating.

Tap the chicken for 5 minutes with a flat knife blade.

Mix eggs, flour, olive oil, white pepper and salt.

Cut the chicken fillets into pieces about 4 cm square.

Coat chicken pieces. Let stand 20 minutes for marinating.

Place the chicken nuggets in the frying basket evenly, put the drawer in the appliance and set the timer for 15-20 minutes or until the nuggets turn a golden-brown colour.



Roasted Lamb Chops

-Lamb chops (at room temperature)	500g
-Brandy or Cognac	1 small glass
-Oil	2 tablespoons
-Powdered pepper	1 teaspoon
-Crushed black pepper	1 teaspoon
-Soy sauce	1 teaspoon
-Salt	1 good pinch

Set the temperature to 200 and the timer to 3 minutes for preheating.

Mix the brandy, the oil, the 2 peppers and the soy sauce.

Note : do not salt before cooking, it hardens the meat.

Mix the seasoning thoroughly and then completely coat the lamb chops with a

kitchen brush. Marinate for 20 minutes.

Place the chops in the frying basket evenly.

Put the drawer in the unit and set the timer for 10-12 minutes or until the chops turn a golden-brown colour.

Take out the drawer and return the chops. Reduce the temperature to 150° and cook another 5 minutes.

Fried Pork Chops



-Pork chops (at room temperature)	500g
-Eggs (beaten)	2pcs
-Flour	1 cup
-Ginger powder	1/2 teaspoon
-Garlic	1 teaspoon
-Chicken soup powder	1/2 teaspoon
-Soy sauce	1/2 teaspoon
-Salt	1/2 teaspoon
-Oil	1 teaspoon

Set the temperature to 200 ° and the timer to 5 minutes for preheating.

Mix the seasoning well, then coat the pork chops with the mixture, marinate for 20 minutes.

Place the pork chops in the basket evenly.

Put the drawer in the device and set the timer for 10-12 minutes

Take out the drawer and return the pork chops. Reduce the temperature to 150 ° and bake for at least 10 minutes or until they turn golden brown.

Fried Squids



-Squid (fresh or thawed)	500g
-Oil	2 tablespoons
-Salt	1 teaspoon
-Cumin powder	1 teaspoon
-Chicken soup powder	1/2 teaspoon
-Powdered pepper	1 teaspoon
-Flour	1 cup

Set the temperature to 200 and the timer to 5 minutes for preheating.

Mix all the ingredients of the seasoning, then smear the squid copiously, let stand 20 minutes;
 Place the squid in the basket evenly.
 Put the drawer in the appliance and set the timer for 10-12 minutes or until the squid turns a golden colour.



Spicy prawns

- Use fresh raw shrimp or Thaw raw shrimp 5/8 pcs p/p
- Oil 2 spoons
- Chopped garlic 1 to 2 cloves
- Crushed black pepper 1 teaspoon
- Sweet chili powder 1 teaspoon
- Powdered white powder 1 teaspoon
- Spicy sauce 10cl

Set the temperature to 200 and the timer to 5 minutes for preheating.
 Rinse the shrimp and dry it.
 Mix the oil, garlic, chilli, cracked black pepper.
 Apply a thin layer of this preparation on shrimp.
 Place the shrimp in the basket evenly,
 Put the drawer in the appliance and set the timer for 5 to 8 minutes or until the layer is crisp and golden.
 Lightly heat the spicy sauce with salt and white pepper in a saucepan, serve immediately.



Fried & Grilled corn

- Corn-cob 2 pcs / p
- Oil olive 1 teaspoon per ear
- Salt
- Pepper

Set the temperature to 200 and the timer to 5 minutes for preheating.
 Apply a thin layer of olive oil on all the corn.
 Place the corncobs in the basket evenly.
 Put the drawer in the appliance and set the timer for 10 minutes so that the ears are crisp and golden.