

WIRELESS VACUUM CLEANER INSTRUCTION MANUAL

TAB-2021



TAB-2025



TAB-2026



Dear consumer, Please read these instructions carefully before use in order to avoid damage due to incorrect use and to better understand the functions of this product. Please pay particular attention to the safety guide.

If you pass the device on to a third party, these Operating Instructions must also be handed over.

Please keep them for future references.

IMPORTANT SAFEGUARDS

- ❑ Please read these instructions carefully before use.
- ❑ Keep present instructions for future references.
- ❑ Check that your mains voltage corresponds to that stated on the appliance.
- ❑ Only use the appliance for domestic purposes and household or similar applications such as:
 - staff kitchen areas, in shops, offices and other working environments;
 - By clients in hotels, motels and other residential type environments;
 - Environment type like :
 - Farm Houses • Bed and Breakfast.
- ❑ Only use the appliance in the way indicated in these instructions.
- ❑ Never use this unit near bathtub, shower, wash-hand basins or other containers with water.
- ❑ Never use this apparatus near water projections.
- ❑ Never use this apparatus with the wet hands.
- ❑ If, unfortunately the apparatus is wet, immediately withdraw the cord of the socket-outlet.
- ❑ Inform potential users of these instructions.
- ❑ Never leave the appliance unsupervised when in use.
- ❑ The appliance must be used only for its intended purpose. No responsibility can be taken for any possible damage caused by incorrect use or improper handling.
- ❑ Children and persons with disabilities are not always aware of the danger posed by the use of appliances.
- ❑ This appliance can be used by children aged from 8 years and above and persons with reduced physical, sensory or mental capabilities or lack of experience and knowledge if they have been given supervision or instruction concerning use of the appliance in a safe way and understand the hazards involved.

- ❑ Children shall not play with the appliance.
- ❑ Cleaning and user maintenance shall not be made by children without supervision.
- ❑ In order to ensure your children's safety, please keep all packaging (plastic bags, boxes, polystyrene etc.) out of their reach.
- ❑ Caution ! Do not allow small children to play with the foil :
THERE IS A DANGER OF SUFFOCATION !
- ❑ From time to time check the cord for damages. Never use the appliance if cord or appliance shows any signs of damage.
- ❑ Never immerse the appliance in water or any other liquid for any reason whatsoever.
- ❑ Never place it into the dishwasher.
- ❑ Never use the appliance near hot surfaces.
- ❑ Do not operate the appliance with a damaged cord or plug, or after the appliance has been damaged in any manner.
- ❑ Disconnect the power source cable before any operation of cleaning of maintenance and accessories assembly.
- ❑ Never use the appliance outside and always place it in a dry environment.
- ❑ Never use accessories, which are not recommended by the producer. They could constitute a danger to the user and risk to damage the appliance.
- ❑ The appliance is only to be used with the power supply unit provided with the appliance.
- ❑ Never move the appliance by pulling the cord. Make sure the cord cannot get caught in any way.
- ❑ Never wind the cord around the appliance and do not bend it
- ❑ Ensure that the power cord does not come into contact with hot parts of this unit.
- ❑ Make sure the appliance has cooled down before cleaning and storing it.
- ❑ The temperature of accessible surfaces may be very high when the appliance is operating. Never touch these parts, of apparatus, to avoid burning itself.

- ❑ Make sure the appliance never comes into contact with flammable materials, such as curtains, cloth, etc...& the power cord and plug do not come in contact with water.
- ❑ Before cleaning, always unplug the appliance from the power supply and let it cool down.
- ❑ This appliance is not intended to be operated by means of an external timer or separate remote-control system.
- ❑ Always place the unit on a flat surface. Ensure, also, not to cover the device and not to put anything on it.
- ❑ Always remove the plug from the wall socket when the appliance is not in use.
- ❑ When using an extension lead always make sure that the entire cable is unwound from the reel. Use solely CE approved extension leads. Input power must be at least 16A, 250V, 3000W.
- ❑ Incorrect operation and improper use can damage the appliance and cause injury to the user.
- ❑ This device, designed for home use, complies with standards relating to this type of product.
- ❑ The appliance must be used and rested on a table or flat & stable surface.
- ❑ The item must not be left unattended when it is connected to main supply.
- ❑ The item is not to be used, if it has been dropped or if there are visible signs of damage or if it is leaking.
- ❑ Regarding the instructions for cleaning, please refer to the below paragraph of the manual.
- ❑ This appliance is only intended for household use.
- ❑ Warning: Avoid spilling on the connector.
There is a potential risk of injury if used incorrectly.
The surface of the heating element may remain hot for some time after use.

(*) **Competent qualified person** : after sales department of the producer or importer or any person who is qualified, approved and competent to perform this kind of repairs.

GENERAL INFORMATION

The symbol "OPEN BOOK" means a recommendation to read important things contained in the record.



The symbol "BIN" crossed out, abbreviation WEEE (Waste of Electrical and Electronic Equipment) means that at the end of life, it should not be discarded with household waste, but filed to the sorting of the locality. Waste recovery can help preserve our environment.



The symbol "CE" is the guarantee of compliance with harmonized European standards, voluntary, reflecting the essential requirements into technical specifications. These standards are not mandatory but are guarantees of compliance with essential requirements.



The symbol ROHS (Restriction of use of some Hazardous Substances) on the Environmental Protection, certifies that for each of the five hazardous substances • Lead • Mercury • (hexavalent) chromium • products for protection against flames PBB and PBDE, the peak concentration is equal to or less than 0.1% of the weight of homogeneous material, and 0.01% for the 6th • cadmium.



The symbol "TRIMAN" indicates that the consumer is invited to dispose the product as part of a separate collection (eg recycling bin, waste, voluntary intake point).



For more information : <http://www.quefairedemesdechets.fr>

TO KNOW THE DEVICE

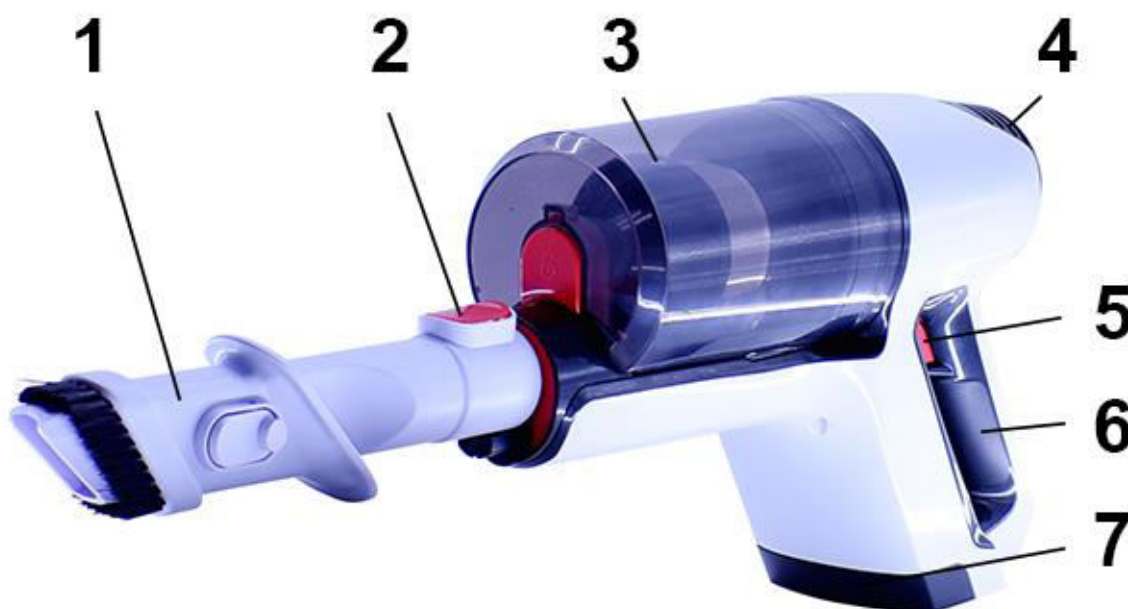

1. Accessory brush + crevice tool + flat crevice tool
2. Tube / vacuum connection
3. Dust tank
4. Power and speed adjustment
5. On / Off switch
6. Handle of the device
7. Battery Pack
8. Tube / vacuum connection
9. Suction tube
10. Foldable patella
11. Tube Connection / Rotating Brush
12. Rotating brush
13. Wall bracket

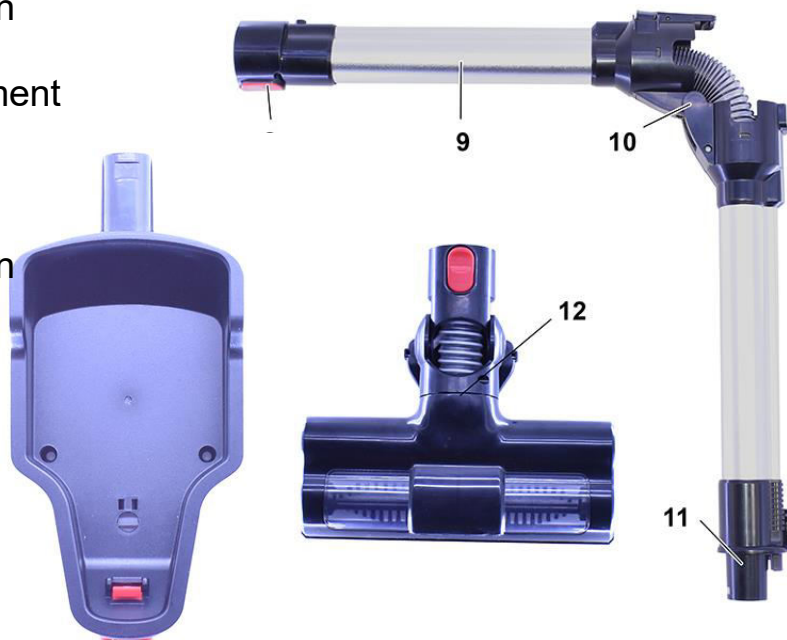

WALL MOUNTING and CHARGING

Fig. 1
Back of the support (1)
Insert the tip of the adapter (2)
in the hole of the loading base.

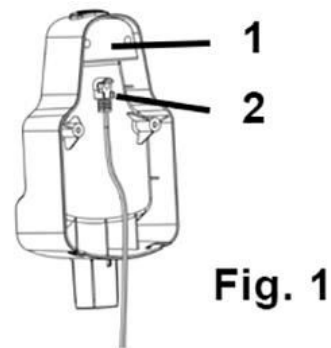
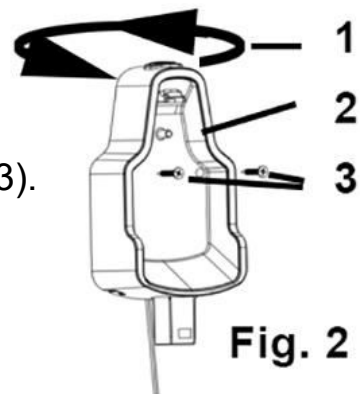

Fig. 2
Flip the support (1)
to present it Front face (2)
Secure the base to the wall with two screws (supplied) (3).



- Unwind the mains lead of the adapter completely.
- Check that the voltage in the country where you are, corresponds to the voltage indicated on the device.

Plug the adapter into a wall outlet.

Place the vacuum cleaner in the charging base (Fig. 3).
Note: The blue light begins flashing to indicate that the unit is charging.

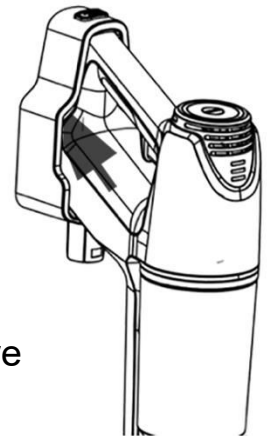

After 4-5 hours, all lights will be on.

Notes: This means that the battery is fully charged.

Charge the device at least 5 hours both first time to preserve the longevity of the battery.

If the vacuum cleaner is not used for a long time, it is still advisable to charge the battery at less once every 6 months.

Press the button above the charging base (1)
to release the unit and start using it.

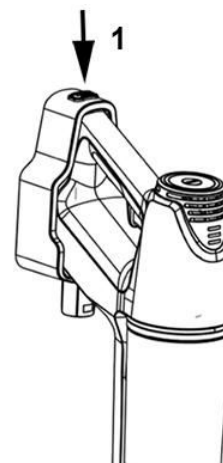

Before use

1. Connect the tube to the vacuum cleaner

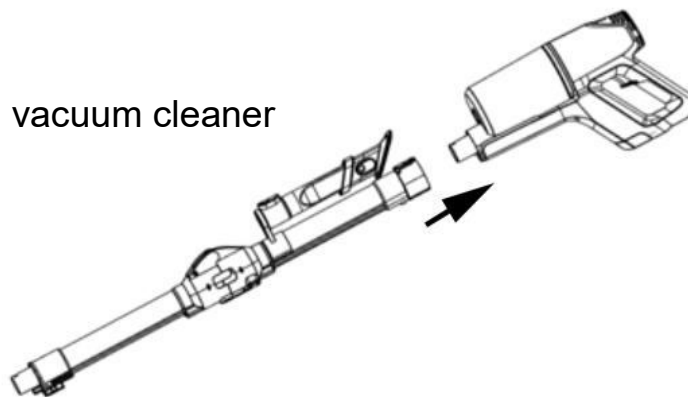

2. Install as desired:
 - a. the electric rotary brush by inserting it with precaution in the other extremity of the tube.

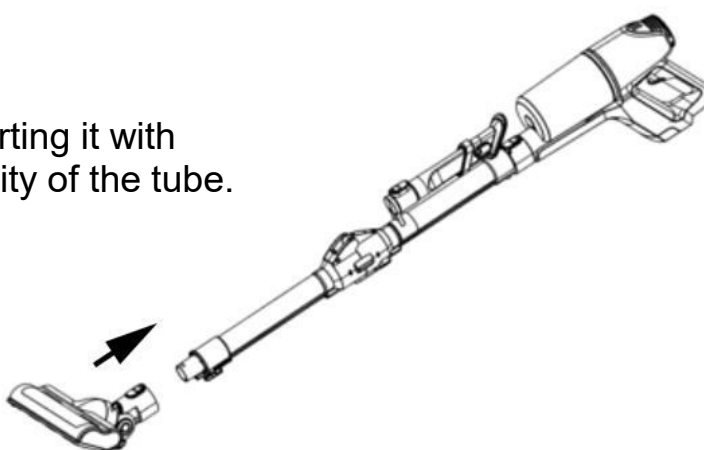

Note: It is possible to connect the rotating brush directly to the device.

- b. Install the 3 in 1 accessory (to vacuum furniture, pillow, recesses etc.) by inserting it carefully Or into the tube, either directly on the suction connection of the device.

USE

Press the on / off switch for 2 seconds to start the vacuum cleaner.

The indicator lights come on.

Press the speed controller, on the back of the unit, to switch to slow or fast speed.

Note: During use, the battery discharges, the 3 charge indicator lights go out one by one.

When the battery is discharged, the last indicator light flashes for 30 to

40

seconds and the machine stops operating.

- Always unplug the power cable from the power supply before performing any maintenance cleaning and accessory fitting.
- Never modify the device.

CLEANING AND MAINTENANCE

Before cleaning, always: switch off the appliance, disconnect the apparatus and let it cool.

Clean the outside of the apparatus with a sponge or slightly wet linen.

Never plunge the apparatus in water or all other liquid!

Do not use abrasive cleaners, gritting, or metal brush or another cutting object.

Remove the tube or accessory from the body of the appliance by pressing the release button.

Detach the tank by pressing the Lock / Unlock button.

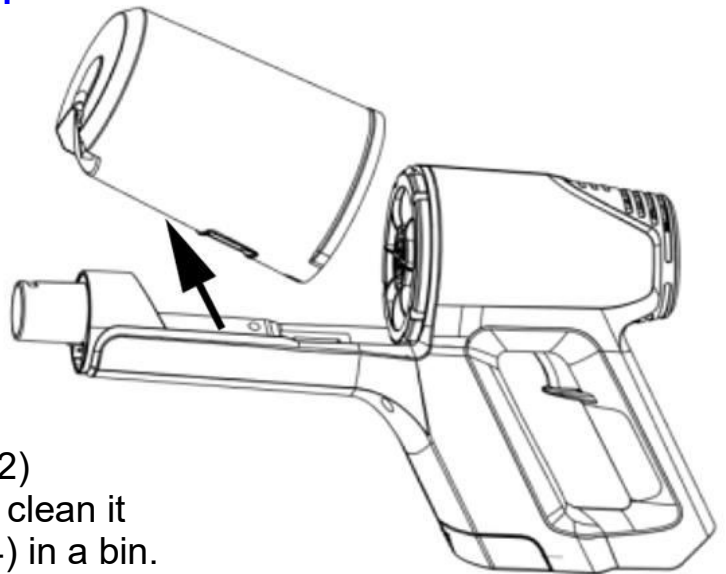

Remove the dust cover (1)

Pull on the filter with the small handle (2)

Remove the filter from the tank (3) and clean it

Empty the dust contained in the tank (4) in a bin.

Clean the tank and refit the assembly by working upside down.

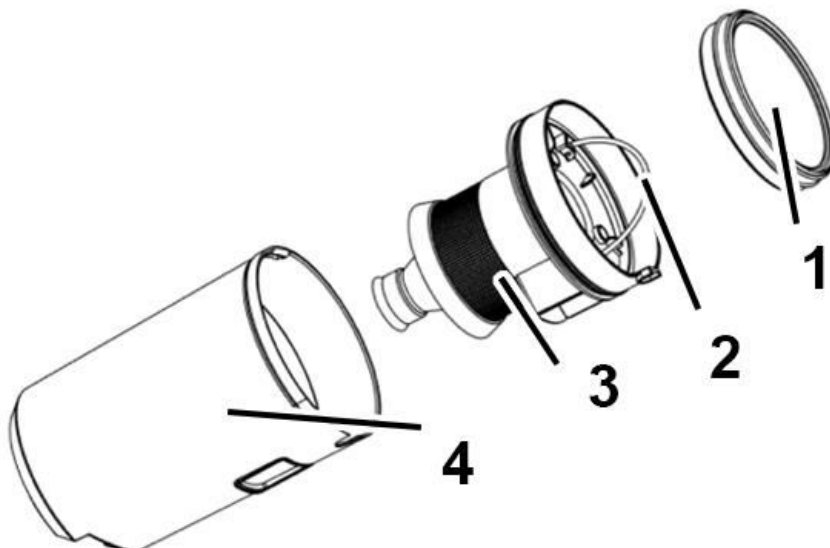

CLEANING THE ROTATING BRUSH

If the brush is clogged, by wires or dirt, the suction will be less.

Stop, the device. Detach the rotating brush from the hose and turn it over.

Carefully, use a pair of scissors, or a knife, to remove annoying items such as threads or hair that may have clogged the brush inlet.

If needed, locate the Lock / Unlock button on the rotating brush shaft. (1)

Insert a screwdriver or coin into the latch slot and turn counter clockwise (2) to release the roller.

Lift the latch (3) and remove the brush roller (4)

Clean it.

Return to the original position and close the latch by turning clockwise.

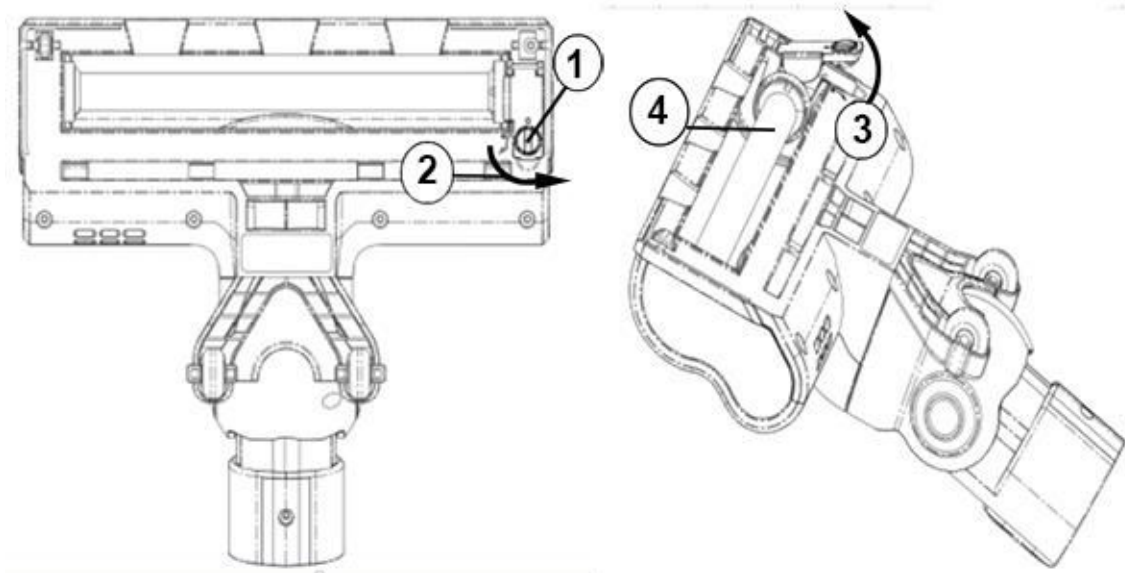

STORAGE

- Ensure the unit is completely cool and dry.
- Do not wrap the cord around the appliance, as this will cause damage.
- Keep the appliance in a cool, dry place and out of reach from children.

GUARANTEE

Before being delivered, all our products are subjected to a rigorous control.

This apparatus is guaranteed 24 months starting from the date of purchase by the consumer.

The documents in proof of guarantee are :

- The invoice and
- The filled and stamped warranty plate (located on side or bottom of the gift box). Without these documents in proof, no free replacement, nor no free repair, can be carried out.

During the warranty period, we deal for free, the defects of the apparatus or the accessories, rising from a defect of materials or manufacture by repair or,

replacement. The services within the framework of the guarantee do not involve any extension of the warranty period and does not give right to a new guarantee! In the event of recourse to the guarantee, bring back the complete apparatus to your retailer, in its original packing, accompanied by the proofs of purchase. The breakage of parts out of glass or plastic is, in all the cases, not warranted. Defects on the accessories or the wearing parts (for example: coils of engines, hooks, drive belts, remote control of replacement, teeth brushes of replacement, webs etc) as well as cleaning, maintenance or it replacement of wearing parts are not guaranteed and are thus to pay! In the event of foreign intervention, the guarantee becomes null and void. After flow of the warranty period, repairs can be carried out, against payment, by a specialized trade or a repair service.

SPECIFICATIONS

UNIT

Power supply 22.2V DC 140W

BRUSH

Power supply 22.2V DC 10W

ADAPTOR Ref: CZH015265050EUWH

Input Power supply 100-240V~ 50/60Hz 0.5A

Output Power 26.5V DC 500mA

Norm Class II

Made in P.R.C

The characteristics can change without prior notice.

This apparatus satisfied EC directives, it was controlled according to all the European current directives, like: electromagnetic compatibility (EMC) and low tension (LVD).

This apparatus was designed and manufactured in respect of the last safety regulations and technical specifications.

ENVIRONMENTAL PROTECTION

(Destruction of batteries)

To remove the battery:

- Open the battery compartment and retrieve the battery or batteries.

The appliance must be disconnected from the supply mains when removing the battery.

- THE BATTERY MUST BE REMOVED BEFORE THE UNIT IS GIVEN TO REBUS.

- BATTERY CONTAINS NICKEL CADMIUM AND / OR LITHIUM AND / OR NICKEL-METAL HYDRIDE, THE BATTERY MUST BE ELIMINATED IN A SAFE WAY.

DO NOT THROW IN A TRASH CAN, BUT GIVE IN CENTRE OF WASTE.

Imported by Sotech International

" LE PERIPOLE " N°A-107

33, Avenue du Marechal de Lattre de Tassigny

94120 Fontenay sous-bois - France