

## WIRELESS VACUUM CLEANER INSTRUCTION MANUAL

**TAB-325**



**TAB-326**



**TAB-328**



Dear consumer, Please read these instructions carefully before use in order to avoid damage due to incorrect use and to better understand the functions of this product. Please pay particular attention to the safety guide.

If you pass the device on to a third party, these Operating Instructions must also be handed over.

Please keep them for future references.

## IMPORTANT SAFEGUARDS

- ❑ The appliance is only to be used with the power supply unit provided with the appliance.
- ❑ Please read these instructions carefully before use.
- ❑ Keep present instructions for future references.
- ❑ Check that your mains voltage corresponds to that stated on the charger.
- ❑ Only use the appliance for domestic purposes and household or similar applications such as:
  - Staff kitchen areas, in shops, offices and other working environments;
  - By clients in hotels, motels and other residential type environments;
  - Environment type like :
    - Farm Houses • Bed and Breakfast.
- ❑ Only use the appliance in the way indicated in these instructions.
- ❑ Never use this unit near bathtub, shower, wash-hand basins or other containers with water.
- ❑ Never use this apparatus near water projections.
- ❑ Never use this apparatus with the wet hands.
- ❑ Inform potential users of these instructions.
- ❑ Never leave the appliance unsupervised when in use.
- ❑ The appliance must be used only for its intended purpose. No responsibility can be taken for any possible damage caused by incorrect use or improper handling.
- ❑ Children and persons with disabilities are not always aware of the danger posed by the use of appliances.
- ❑ This device can be used by children aged 8 years and older and adults, with reduced physical, sensory or mental capabilities or lack of experience and knowledge, if they have been given supervision or instruction concerning use of the appliance in a safe way and understand the hazards involved.

- Children shall not play with the appliance.
- Cleaning and user maintenance shall not be made by children unless they are supervised.
- Keep the appliance and its charger out of reach of children aged less than 8 years of age when it is energized or cooling down.
- This device is not a toy, do not leave small children or people with disabilities to play with.
- The appliance is only to be used with the charger provided with the appliance.
- The appliance must only be supplied at safety extra low voltage corresponding to the marking on the appliance.
- Disconnect the charger if it is plugged in the wall socket before cleaning or maintaining the appliance.
- In order to ensure your children's safety, please keep all packaging (plastic bags, boxes, polystyrene etc.) out of their reach.
- Caution ! Do not allow small children to play with the foil :  
**THERE IS A DANGER OF SUFFOCATION !**
- From time to time check the cord of the charger for damages. Never use the appliance if cord or appliance shows any signs of damage.
- Never immerse the appliance in water or any other liquid for any reason whatsoever.
- Never place it into the dishwasher.
- Never use the appliance near hot surfaces.
- Do not operate the appliance with a damaged cord or plug, or after the appliance has been damaged in any manner.
- Never use the appliance outside and always place it in a dry environment.
- Never use accessories, which are not recommended by the producer. They could constitute a danger to the user and risk to damage the appliance.

- ❑ Ensure that the power cord of the charger does not come into contact with hot parts of this unit.
- ❑ Make sure the appliance has cooled down before cleaning and storing it.
- ❑ Before cleaning, always unplug the charger from the power supply and let it cool down.
- ❑ Always place the unit on a flat surface. Ensure, also, not to cover the device and not to put anything on it.
- ❑ Incorrect operation and improper use can damage the appliance and cause injury to the user.
- ❑ This device, designed for home use, complies with standards relating to this type of product.
- ❑ The appliance must be used and rested on a table or flat & stable surface.
- ❑ The item must not be left unattended
- ❑ The item is not to be used, if it has been dropped or if there are visible signs of damage or if it is leaking.
- ❑ This appliance is only intended for household use.

## GENERAL INFORMATION

The symbol "OPEN BOOK" means a recommendation to read important things contained in the record.



The symbol "BIN" crossed out, abbreviation WEEE (Waste of Electrical and Electronic Equipment) means that at the end of life, it should not be discarded with household waste, but filed to the sorting of the locality. Waste recovery can help preserve our environment.



The symbol "CE" is the guarantee of compliance with harmonized European standards, voluntary, reflecting the essential requirements into technical specifications. These standards are not mandatory but are guarantees of compliance with essential requirements.



The symbol ROHS (Restriction of use of some Hazardous Substances) on the Environmental Protection, certifies that for each of the five hazardous substances • Lead • Mercury • (hexavalent) chromium • products for protection against flames PBB and PBDE, the peak concentration is equal to or less than 0.1% of the weight of homogeneous material, and 0.01% for the 6th • cadmium.



The symbol "III" means that the equipment concerned is designed to be supplied at a voltage of not more than 50 volts AC or 120 volts DC. Materials with this sign are classified as Class III.



The symbol "TRIMAN" indicates that the consumer is invited to dispose the product as part of a separate



collection (e.g. recycling bin, waste, voluntary intake point).

For more information : <http://www.quefairedemesdechets.fr>

### TO KNOW YOUR DEVICE

1. On-off switch and speed selector
2. Charging indicator
3. Tube release button
4. Tube connecting the unit and the brush
5. Brush release button
6. Battery
7. Unlock button on the battery
8. Air outlet
9. Cyclonic system and filter
10. Dust tank
11. Reservoir release button
12. Motorized rotary brush
13. Electric charger
14. Fine brush and crevice
15. wall mount for vacuum cleaner

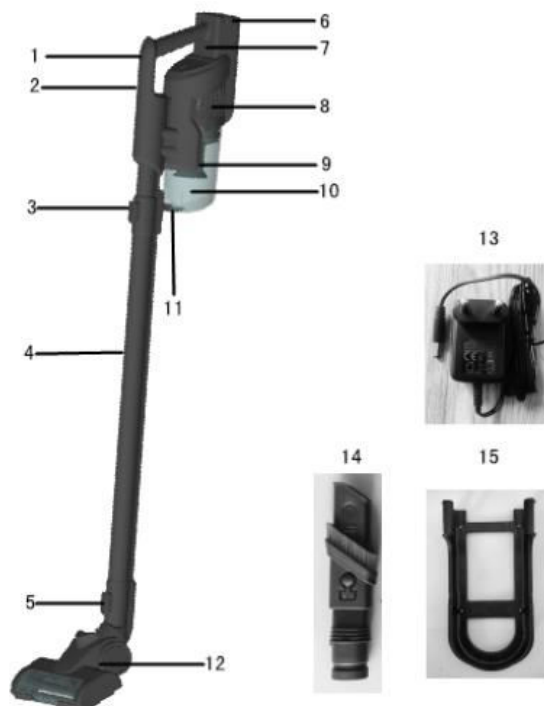

2 in 1 accessory:

- 1- Long nozzle and flat,
- 2- Mini brush



### FIRST USE

Before first use, remove the unit and all accessories carefully and paying attention to the sharp accessories.

Clean the outside and inside of the machine cabinet with a damp cloth and wipe dry.

## MOUNTING

Assemble the Vacuum / Brush connection tube by inserting the tube into the upper part of the brush and into the lower part of the appliance until it clicks into place.



To remove the tube, press the release button with one hand and pull the tube with the other hand.

*NOTES: It is possible to directly assemble the vacuum cleaner and the brush without using the tube. To do this, proceed in the same way with the tube (upper part of the brush) and the vacuum cleaner.*

It is possible to assemble the accessory 2 in 1 to suck furniture, pillow, nooks etc. by inserting it carefully Either into the tube, either directly to the base of the device.



## CHARGING THE BATTERY

Connect the charger to the unit (make sure the unit is off), then connect it to the AC outlet. When the unit is plugged in, the indicator light flashes. It takes about 3 hours to fully charge the battery before the first use. The indicator light will be fix when the battery is fully charged.

*Notes: Always leave the device on its stand (with the charger) when is not used.*

*This is to ensure that it will always be ready for use.*

*The charger may become hot during charging, this is normal.*

In use, the battery discharges. When the charging light flashes, it is necessary to charge the battery.

Make sure the unit is fully charged before using.

After installing accessory, choice if you used brush or not and then press the switch on the handle to start the unit.

*Note: One pressure : The vacuum starts running at the "Eco" speed, (the unit runs at low speed). Two pressures : the vacuum cleaner will operate at its maximum speed. You can select the speed according to your needs.*

To stop the vacuum, press the switch a third time.

## CLEANING AND MAINTENANCE

Before cleaning, disconnect the charger if it is plugged in the wall socket.

Clean the outside of the apparatus with a sponge or slightly wet linen.

Never plunge the apparatus in water or all other liquid!

Do not use abrasive cleaners, gritting, or metal brush or another cutting object.

Remove the tube or accessory from the body of the appliance by pressing the release button.



Remove the dust container by pressing the button (1).

Remove the tank from its housing in the appliance (2).

Empty the garbage on top of a bin (3).

Clean the tank and replace it.

Clean the plastic filter if necessary (possibly with a toothbrush) to remove small dust. Wash, rinse and dry. Make sure the parts are dry before assembling them for the next use.



## Hepa filter and sponge filter



Remove the Hepa filter and the sponge filter (the second, located inside the cyclonic system.) (1).

Wash under running water. (2)

Allow to dry in the open air. (3)

Reinstall the filters before next use. (make sure the 2 Hepa and sponge filters are dry before reinstalling them).

Note: If any of the filters are damaged or dirty, replace it with a new filter.

## CLEANING THE BRUSH

If the brush is obstructed, by wires or dirt, the suction will be less good.

Stop, disconnect from stand and turn the rotating brush. Carefully use a pair of scissors, or a knife, to remove annoying items such as wires or hair that may have clogged the brush inlet.

If needed, locate the Lock / Unlock button on the motorized brush shaft (1) And push outward to release the roll.

Lift (2) and remove the brush roll.

Clean it.

Return it to the original position and close the Lock until "click".

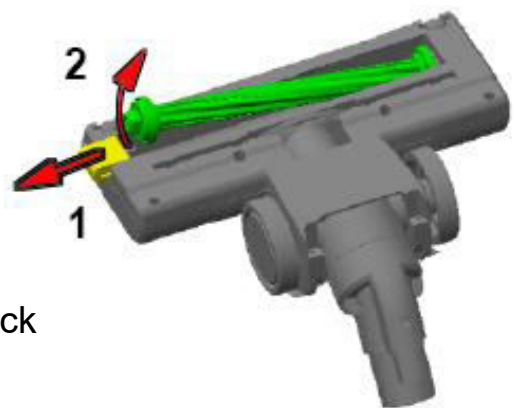

## STORAGE

- Ensure the unit is completely cool and dry.
- Do not wrap the cord of the charger around the appliance, as this will cause damage.
- Keep the appliance in a cool, dry place and out of reach from children.

## GUARANTEE

Before being delivered, all our products are subjected to a rigorous control. This apparatus is guaranteed 24 months starting from the date of purchase by the consumer.

The documents in proof of guarantee are:

- The invoice and
- The filled and stamped warranty plate (located on side or bottom of the gift box). Without these documents in proof, no free replacement, nor no free repair, can be carried out.

During the warranty period, we deal for free, the defects of the apparatus or the accessories, rising from a defect of materials or manufacture by repair or, replacement. The services within the framework of the guarantee do not involve any extension of the warranty period and does not give right to a new guarantee! In the event of recourse to the guarantee, bring back the complete apparatus to your retailer, in its original packing, accompanied by the proofs of purchase. The breakage of parts out of glass or plastic is, in all the cases, not warranted. Defects on the accessories or the wearing parts (for example: coils of engines, hooks, drive belts, remote control of replacement, teeth brushes of replacement, webs etc) as well as cleaning, maintenance or it replacement of wearing parts are not guaranteed and are thus to pay!

In the event of foreign intervention, the guarantee becomes null and void.

After flow of the warranty period, repairs can be carried out, against payment, by a specialized trade or a repair service.

## SPECIFICATIONS

### UNIT

|              |           |
|--------------|-----------|
| Power supply | 22,2V DC  |
| Norm         | Class III |

### BRUSH

|              |          |
|--------------|----------|
| Power supply | 22,2V DC |
|--------------|----------|

### CHARGER

|                    |                         |
|--------------------|-------------------------|
| Input Power supply | 100-240V~ 50/60Hz 0,4 A |
| Output Power       | 26V DC 450mA            |
| Norm               | Class II                |

Made in P.R.C

*The characteristics can change without prior notice*

Always unplug the appliance before any cleaning or maintenance operation and accessories assembly.

This apparatus satisfied EC directives, it was controlled according to all the European current directives, like: electromagnetic compatibility (EMC) and low tension (LVD).

This apparatus was designed and manufactured in respect of the last safety regulations and technical specifications.

## **ENVIRONMENTAL PROTECTION**

(Destruction of batteries)

To remove the battery:

Disconnect the charger if it is plugged in the wall socket before removing the battery.

- Open the battery compartment and retrieve the battery or batteries.

- THE BATTERY MUST BE REMOVED BEFORE THE UNIT IS GIVEN TO REBUS.

- BATTERY CONTAINS NICKEL CADMIUM AND / OR LITHIUM AND / OR NICKEL-METAL HYDRIDE, THE BATTERY MUST BE ELIMINATED IN A SAFE WAY.

DO NOT THROW IN A TRASH CAN, BUT GIVE IN CENTRE OF WASTE.

**Imported by Sotech International**

**" LE PERIPOLE " N°A107**

**33, Avenue du Marechal de Lattre de Tassigny**

**94120 Fontenay sous Bois - France**