

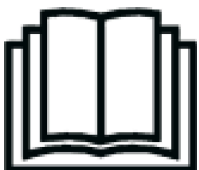

MULTIFUNCTION KITCHEN MACHINE

INSTRUCTION MANUAL



Dear consumer, Please read these instructions carefully before use in order to avoid damage due to incorrect use and to better understand the functions of this product. Please pay particular attention to the safety guide.

If you pass the device on to a third party, these Operating Instructions must also be handed over.

Please keep them for future references.

IMPORTANT SAFEGUARDS

- Please read these instructions carefully before use.
 - Keep present instructions for future references.
 - Check that your mains voltage corresponds to that stated on the appliance.
 - Only use the appliance for domestic purposes and household or similar applications such as:
 - staff kitchen areas, in shops, offices and other working environments;
 - Environment type like :
 - Farm Houses • Bed and Breakfast.
 - by clients in hotels, motels and other residential type environments;
- Only use the appliance in the way indicated in these instructions.
- Never use this unit near bathtub, shower, wash-hand basins or other containers with water.
 - Never use this apparatus near water projections.
 - Never use this apparatus with the wet hands.
 - If, unfortunately the apparatus is wet, immediately withdraw the cord of the socket-outlet.
 - Inform potential users of these instructions.
 - Never leave the appliance unsupervised when in use.
 - The appliance must be used only for its intended purpose. No responsibility can be taken for any possible damage caused by incorrect use or improper handling.
 - Children and persons with disabilities are not always aware of the danger posed by the use of appliances.
 - This appliance shall not be used by children.
 - This appliance can be used by persons with reduced physical, sensory or mental capabilities or lack of experience and knowledge if they have been given supervision or

instruction concerning use of the appliance in a safe way and if they understand the hazards involved.

- Cleaning and maintenance must not be made by children.
- Keep the appliance and its cord out of reach of children.
- This device is not a toy, do not leave children or people with disabilities to play with.
- In order to ensure your children's safety, please keep all packaging (plastic bags, boxes, polystyrene etc.) out of their reach.
- Caution ! Do not allow small children to play with the foil :
THERE IS A DANGER OF SUFFOCATION !
- From time to time check the cord for damages. Never use the appliance if cord or appliance shows any signs of damage.
- Never immerse the appliance in water or any other liquid for any reason whatsoever.
- Never place it into the dishwasher.
- Never use the appliance near hot surfaces.
- If the supply cord is damaged, it must be replaced by the manufacturer, its service agent or similarly Competent qualified person^(*) in order to avoid a hazard.
- Disconnect the power source cable before any operation of cleaning of maintenance and accessories assembly.
- Never use the appliance outside and always place it in a dry environment.
- Never use accessories, which are not recommended by the producer. They could constitute a danger to the user and risk to damage the appliance.
- Never use any other connector than the one provided.
- Never move the appliance by pulling the cord. Make sure the cord cannot get caught in any way.
- Never wind the cord around the appliance and do not bend it

- Ensure that the power cord does not come into contact with hot parts of this unit.
- Make sure the appliance has cooled down before cleaning and storing it.
- The temperature of accessible surfaces may be very high when the appliance is operating. Never touch these parts, of apparatus, to avoid burning itself.
- Make sure the appliance never comes into contact with flammable materials, such as curtains, cloth, etc...& the power cord and plug do not come in contact with water.
- Before cleaning, always unplug the appliance from the power supply and let it cool down.
- This appliance is not intended to be operated by means of an external timer or separate remote-control system.
- Always place the unit on a flat surface. Ensure, also, not to cover the device and not to put anything on it.
- Always remove the plug from the wall socket when the appliance is not in use.
- When using an extension lead always make sure that the entire cable is unwound from the reel. Use solely CE approved extension leads. Input power must be at least 16A, 250V, 3000W.
- Incorrect operation and improper use can damage the appliance and cause injury to the user.
- This device, designed for home use, complies with standards relating to this type of product.

(*) **Competent qualified person** : after sales department of the producer or importer or any person who is qualified, approved and competent to perform this kind of repairs.

USING FOR THE FIRST TIME

- Read this handbook to familiarize yourself with all the parts of your new food processor.
- Clean all the parts and accessories in contact with food before using the appliance for the first time (see paragraph “Cleaning”).

Warning !

- Do not attempt to remove the kneading arms or whips at the start of the unit.
- Robot cannot be used to mix dry and hard foods. it may damage the used arm.
- The whip is to be used only for whites egg or liquid culinary preparations consistency. In use for a hard paste, it may be permanently damaged.
- Before removing, the unit's motor must be completely stopped, and unit unplugged.
- Always use the button to control the opening or closing of the robot arm.
- Keep hands, clothing, moved away from kneading arm during operation to reduce the risk of injury and damage.
- Operate only one accessory at a time: Blender OR Mixer OR chopper !
- The chopper blade is very sharp ! be extremely careful when handling to avoid the risk of injury.
- Use a spatula to remove the food.
- Always put the lid to operate the blender and check that the cover is securely in place before operating the unit.
- If the blender does not start running, check its position. It is advisable to remove and refit it.

IMPORTANT : To use the robot without the blender in place, it will only work if the

base cover is securely screwed to the location of the blender.

SPECIFIC WARNINGS FOR MULTIFUNCTIONS KITCHEN MACHINES

Warning !

- Always disconnect the appliance from the supply if it is left unattended and before assembling, disassembling or cleaning.
- Switch off the appliance and disconnect from supply before changing accessories or approaching parts that move in use.
- Potential injury may occur during misuse. Care should be taken when handling sharp blades, emptying the bowl and during cleaning as they are extremely sharp.
 - For instructions on cleaning surfaces in contact with food or oil, please refer to the "**CLEANING & MAINTENANCE**" paragraph in the manual.
- For instructions on the use of accessories, operating time and speed settings, refer to the paragraphs below.

GENERAL INFORMATION

The symbol "OPEN BOOK" means a recommendation to read important things contained in the record.

The symbol "BIN" crossed out, abbreviation WEEE (Waste of Electrical and Electronic Equipment) means that at the end of life, it should not be discarded with household waste, but filed to the sorting of the locality. Waste recovery can help preserve our environment.

The symbol "CE" is the guarantee of compliance with harmonized European standards, voluntary, reflecting the essential requirements into technical specifications. These standards are not mandatory

but are guarantees of compliance with essential requirements.

The symbol ROHS (Restriction of use of some Hazardous Substances) on the Environmental Protection, certifies that for each of the five hazardous substances • Lead • Mercury • (hexavalent) chromium • products for protection against flames PBB and PBDE, the peak concentration is equal to or less than 0.1% of the weight of homogeneous material, and 0.01% for the 6th • cadmium.

The symbol "DOUBLE SQUARE" means a double insulated. A basic insulation and supplementary insulation. This device requires no connection to the mass of a protective conductor grounded. The materials are said : double insulation class II.

The symbol "GLASS / FORK" means that the device is compatible and can come into contact with foodstuffs.

The symbol "TRIMAN" indicates that the consumer is invited to dispose the product as part of a separate collection (eg recycling bin, waste, voluntary intake point).

For more information : <http://www.quefairedemesdechets.fr>

CLEANING & MAINTENANCE

Always unplug from power outlet before any cleaning jobs.

Clean the outside of the apparatus with a sponge or slightly wet linen.

Do not wash it under running water and do not submerge it in water or other liquids.

The parts (removable) in contact with food like plate, bowl, forks, Spatula etc. can be washed in hot water with sponge and soft detergent or put in the dishwasher.

- For hand washing use tepid water and normal washing up detergent, being careful of the steel blade, as it is very sharp;
- Washing in the dishwasher-place accessories in the upper part and make sure the water never exceeds maximum temperature of 50°C

Do not use chemical or abrasive substances.

Note!

When you have finished cleaning make sure the parts controlled by the bowl safety system (motor unit at the point where the lip of the lid fits into place) and for models with blender jugs (jug housing on the motor unit, blender jug and lid), are not obstructed by solid waste. If necessary use a soft brush to clean eventual residuals with the appliance unplugged from the mains.

The blades cannot be sharpened. Replace them if they are not cutting properly or are worn.

TO KNOW IT'S UNIT

1. Tray for food to chop
2. Graduated glass Blender
3. Lid with filler cap
4. Jar handle
5. Lifting part of the robot
6. Lock / Unlock button
7. Speed selector + Pulse

8. Nonslip Feet
9. Stainless steel 6,5L bowl
10. Anti-splash lid
11. Meat Grinder

BEFORE THE FIRST USE

Before first use, remove the device and all accessories and being careful with sharp accessories.

- Clean the apparatus according to the instructions in "Cleaning" paragraph.
- Place the machine on a suitable flat, stable surface.

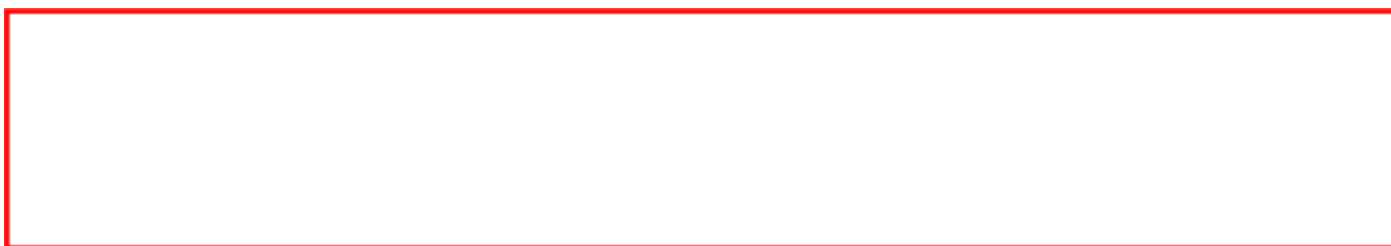

**ANY QUESTIONS REGARDING THE START OR PERFORMANCE
OF THE FOOD PROCESSOR,
CALL THE FOLLOWING PHONE NUMBER :
01 48 93 93 10 (call with no surcharge).**

Before placing the bowl, check that the device is disconnected and the gear selector is in "0" position.

VERY IMPORTANT : THE UNIT WORKS ONLY WHEN THE BLENDER & THE MIXER AND ARE PERFECTLY IN PLACE AND SAFETY ENGAGED.
IF THE UNIT DOES NOT START, IT IS NOT NECESSARILY IN TROUBLE, ANY PARTS MAY NOT BE IN PLACE OR LOCKED WELL.

FOR SAFETY REASONS, we advise you not to use the blender at the same time as other accessories.

SAFETY COVERS

Depending on which function is used:

1. Mixer

Slide the safety cover 1 from the top to the bottom of the meat grinder space.
(On the front of the unit).

Install the safety cover 2 in the area provided for the Blender.
(On top of the unit).

2. Chopper

Slide the safety lid 1 from the bottom to the location of the meat grinder to open the entry.
(On the front of the unit).

Install the safety cover 2 in the location provided for the Blender.
(On top of the unit).

3. Blender

Slide the safety cover 1 from the top to the bottom of the meat grinder space.
(On the front of the unit).

Remove the safety cover 2 at the location for the Blender.

Position the safety lids in place of the unused accessories.

Do not insert whisk or beater using the chopper or blender.

By using the Blender or Chopper, the mixer axis will run idle and this is normal.

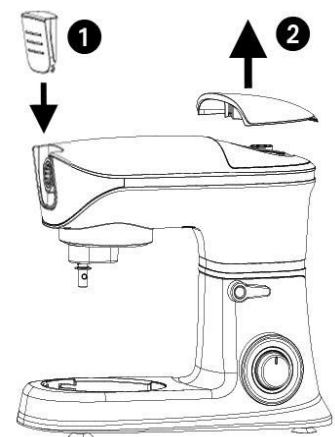

USE

- Unroll the power cord completely.
- Check that the tension in force in the country where you are, corresponds to that indicated on the apparatus.
- Connect the apparatus in a correct socket-outlet, (and connected to the ground if the unit is Class I), to avoid any danger.
- Disconnect the power source cable before any operation of cleaning of maintenance and accessories assembly.
- Never modify the appliance in anyway.

Never exceed the maximum quantities below.

Never pour liquids hotter than 75°C into the bowl and/or blender

Follow the instructions given below, every time you use it :

- Never leave the appliance unattended while it is on.
- Never make the appliance work while it is empty.
- Never touch the moving parts.
- Never put your fingers or utensils inside the lid opening.
- Never press down the ingredients into the lid opening with your hands.
- Do not use the appliance to work hard ingredients (frozen meat, crusts of cheese...), rubbery (candied peel...), and uneatable parts of ingredients (bones, fishbone...).
- Do not remove the lid and never replace accessories without switching off the appliance.
- Do not reassemble the appliance while it is still plugged working.

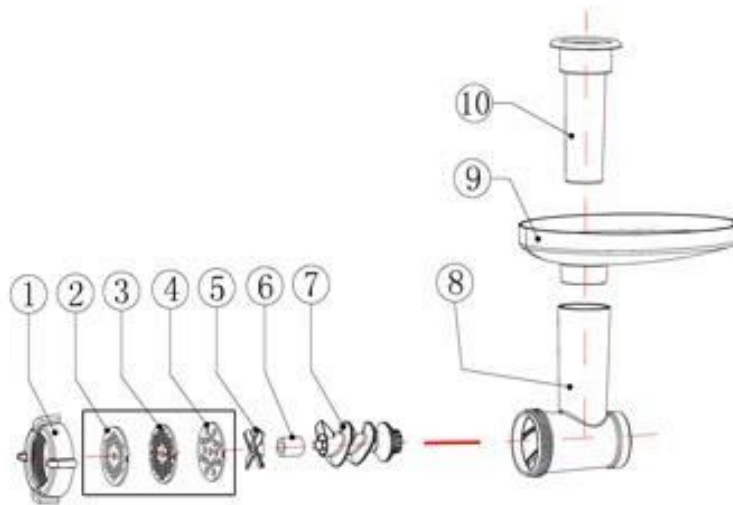

MEAT GRINDER

Fit the safety covers of the other accessories (see previous paragraph).

Mount the silicone part (6) on the spiral connection (7).

Fit the cutting blade (5) onto the spiral connection (7).

Note: Sharp edges of the cutter should point to the hashing disk.

Fit one of the three discs (2, 3, 4) in front of the cutting blade (5).

Turn the chopping disc so that the notches are aligned and enter the lugs on the chopper body.

Note: Select the hash disk according to the consistency required.

You can choose fine, medium or coarse.

Fit the ring (1) in front of the chopping disc on the chopper body.

Turn clockwise to lock.

Note: The ring must hold the hash disk securely in place, but do not Too tight.

Once the chopper has been fitted, install it on the robot (1).

Turn the chopper counter clockwise to fix it (2).

Cut the pieces

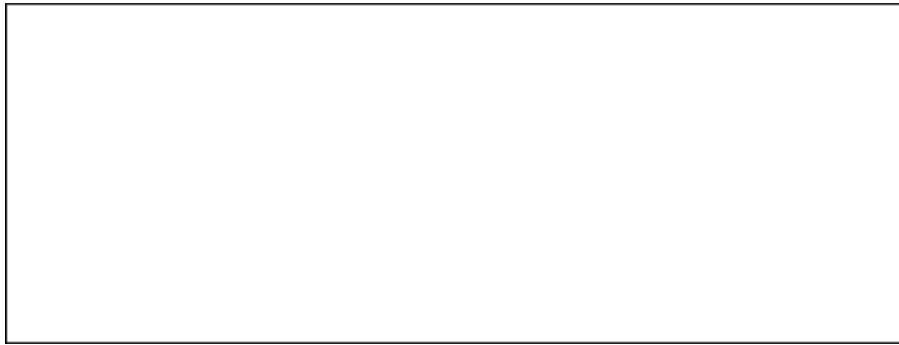

meat into (about) 2 cm.

Insert the meat into the mincer tube, use the pusher if necessary to push the meat into the tube.

Always select the maximum speed (6).

Tip: At the end of the use, pass a little hard bread in the chopper, this will allow all the pieces of meat to be chopped and recovered at the exit.

After use, reset the speed to "0", unplug the robot and remove the chopper.

Tip: always clean the chopper quickly after use to prevent meat waste from drying

in and being more difficult to remove.

WARNING ! The blade is sharpened and sharp, hold the work-piece carefully.

KNEADING

Fit the safety covers of the other accessories (see paragraph above).

Press the open / close button and raise the upper part of the robot.

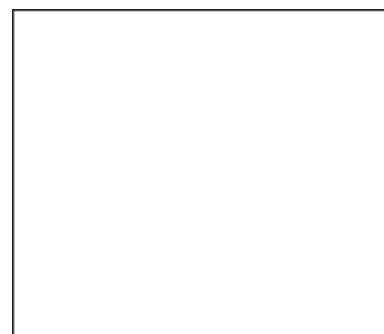

Install the bowl lid (1) on the spindle.
Turn clockwise to secure.

Install the bowl on its base (2).
Turn clockwise to secure.

Install the accessory (whip or hook or beater) on the axis of the robot by engaging it in the axis (3).
Turn counter-clockwise (left) to lock.

Press the open / close button to lower the top of the robot.
Check that it is properly secured before turning it on.

Pour the ingredients into the bowl. (Or pour them before attaching the bowl).

INGREDIENTS LIST

Material	Max. quantity	Remark	Tool
Stiff yeast dough	1500g	Flour and water at a ratio of 5:3, Pre-treatment of dough: From speed 1 for 180second; Operation period: Speed 2 for 10second	
Soft yeast dough	2000g	Flour and water at a ratio of 1.1:1 Pre-treatment of dough: From speed 1 for 90 second; Operation period: Speed 2 for 10 second	
Eggs	24 eggs		

		Switch on speed 8 to speed 10, whip the egg whites without stopping for 3-4min	
Whipped cream	300ml fresh cream	From speed 1 to 4 for about 5minutes	
Shakes, cocktails or other liquids	1 L	Beating eggs into creamed mixtures From speed 1 for about 4minutes	

Caution! These tips are purely indicative.
Refer to personal experience for even better results.

Beater : For making cakes, biscuits, pastry, icing, fillings, mashed potato.

Whisk : For eggs, cream, batters, fatless sponges, meringues, cheesecakes mousses, souffles.
Don't use the whisk for heavy mixtures you could damage it.



Dough hook : For yeast mixtures.

Blender function

Fit the safety covers of the other accessories (see above paragraph).
Add the ingredients to mix in the blender.
Put the lid on. (With the cup in the centre of the lid).
Place the blender on its location on the robot (1).
Turn the blender clockwise to lock it (2).

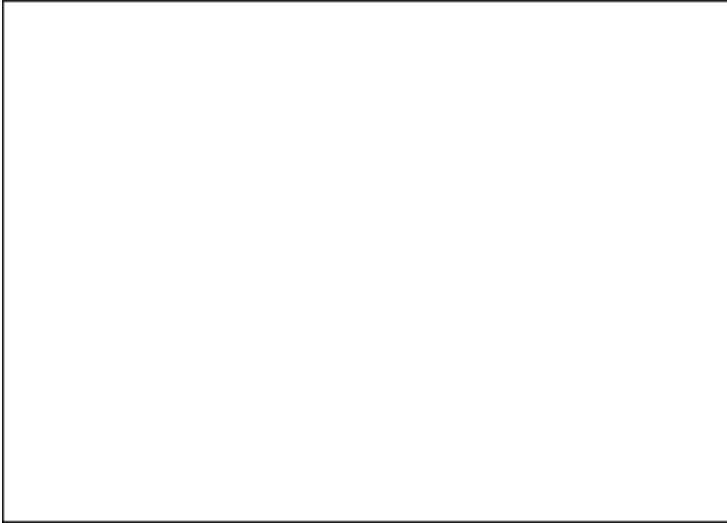

Connect the unit and turn the speed selector to the desired speed.
NOTE: The removable cap of the lid allows the addition of ingredients during the mixing process, with safety.

RECIPE SUGGESTION

To mix or knead dough:

Suggestion flour and water at a ratio of 5 / 3.

From speed 1 for mix 10 s and speed 2 for mix 10 second, afterwards, speed 3 for about 3 minutes.

When filling the mixing bowl, please ensure that the maximum quality is not exceeded.

Maximum quantity of flour is 1500g .

The dough beater or mixer beater should be used.

Whipping egg whites or cream:

- Switch on speed 4 to speed 6, whip the egg whites without stopping for about 5 minutes, according to the size of the eggs, until stiff.
- Maximum quantity 24 eggs.
- For whipped cream, whip 250ml fresh cream at speed 4 to 6 for about 5 minutes.
- When filling the mixing bowl with fresh milk, cream or other ingredients, please ensure that the maximum quality is not exceeded.
- The egg beater should be used.

Mixing shakes, cocktails or other liquids:

1. Mix the ingredients according to the available recipe, from speed 1 to 6 for about 5 minutes.
2. Do not exceed the maximum quantity for the agitator kettle.
3. The mixer beater should be used.

Maximum operating time 10 minutes.

- Trick**
- 1 Switch off and scrape the bowl with the spatula frequently.
 - 2 Eggs at room temperature are best for whisking.
 - 3 Before whisking egg make sure there's no grease or egg yolk on the whisk or bowl.
 - 4 Use cold ingredients for pastry unless your recipe says otherwise.

Point for bread making

- 1 Never exceed the maximum capacity, otherwise you will overload the appliance.
- 2 If you hear the appliance labouring, switch off, remove half the dough and do each half separately.
- 3 The ingredients mix best if you put the liquid in first.

Blender suggestion

Material	MAX. QUANTITY	MAXIMUM TIMES (s)
apple	250g	30s
orange	300g	30s
grape	250g	30s
strawberry	250g	30s

STORAGE

- Ensure the unit is completely cool and dry.
- Do not wrap the cord around the appliance, as this will cause damage.
- Keep the appliance in a cool, dry place.

Your food processor has a space-saving storage system where all accessories can be put away tidily in the bowl.

CAUTION !

To avoid damages never use the appliance with accessories still inside the bowl.

GUARANTEE

Before being delivered, all our products are subjected to a rigorous control. This apparatus is guaranteed 24 months starting from the date of purchase by the consumer.

The documents in proof of guarantee are :

- The invoice and
- The filled and stamped warrantee plate (located on side or bottom of the gift box). Without these documents in proof, no free replacement, nor no free repair, can be carried out.

During the warranty period, we deal for free, the defects of the apparatus or the accessories, rising from a defect of materials or manufacture by repair or, replacement. The services within the framework of the guarantee do not involve any extension of the warranty period and does not give right to a new guarantee ! In the event of recourse to the guarantee, bring back the complete apparatus to your retailer, in its original packing, accompanied by the proofs of purchase.

The breakage of parts out of glass or plastic is, in all the cases, not warranted. Defects on the accessories or the wearing parts (for example: coals of engines, hooks, drive belts, remote control of replacement, teeth brushes of replacement, webs etc) as well as cleaning, maintenance or it replacement of wearing parts are not guaranteed and are thus to pay !

In the event of foreign intervention, the guarantee becomes null and void.

After flow of the warranty period, repairs can be carried out, against payment, by a specialized trade or a repair service.

SPECIFICATIONS

Power supply	220-240V~ 50Hz
Power	1300W for Kneader & Blender 300W for Grinder
Norm	Class II

Made in PRC

The characteristics can change without preliminary preventing

CAUTION: In order to minimize the risks of electric shock, In the event of breakdown, not to open the case but to call upon a qualified technician for repairs.

This device complies with EC directives, it was controlled according to all current European directives, applicable such as: electromagnetic compatibility (EMC) and low voltage (LVD).

This device has been designed and manufactured in compliance with the latest regulations and technical requirements for safety.

**Imported by Sotech International
" LE PERIPOLE " N°A-107
33, Avenue du Marechal de Lattre de Tassigny
94120 Fontenay sous-bois - France**