





TEST REPORT IEC 61558-2-16	
Safety of power transformers, power supplies, reactors and similar products for supply voltages up to 1100 V Part 2: Particular requirements and tests for switch mode power supply units and transformers for switch mode power supply units	
Report Number..... :	65.250.18.010.05
Date of issue..... :	2023-03-21
Total number of pages	166
Name of Testing Laboratory preparing the Report	TÜV SÜD Certification and Testing (China) Co., Ltd. Shenzhen Branch
Applicant's name	
Address..... :	
Test specification:	
Standard	IEC 61558-2-16:2009, AMD1:2013 used in conjunction with IEC 61558-1:2017
Test procedure	GS Scheme and CE_LVD
Non-standard test method	N/A
Test Report Form No. :	IEC61558_2_16G
Test Report Form(s) Originator :	Intertek Testing Services (Singapore) Pte Ltd
Master TRF	Dated 2020-02-21
Copyright © 2020 IEC System of Conformity Assessment Schemes for Electrotechnical Equipment and Components (IECEE System). All rights reserved. This publication may be reproduced in whole or in part for non-commercial purposes as long as the IECEE is acknowledged as copyright owner and source of the material. IECEE takes no responsibility for and will not assume liability for damages resulting from the reader's interpretation of the reproduced material due to its placement and context. This report is not valid as a CB Test Report unless signed by an approved CB Testing Laboratory and appended to a CB Test Certificate issued by an NCB in accordance with IECEE 02.	
General disclaimer:	
The test results presented in this report relate only to the object tested. This report shall not be reproduced, except in full, without the written approval of the Issuing CB Testing Laboratory. The authenticity of this Test Report and its contents can be verified by contacting the NCB, responsible for this Test Report.	

Test item description	SWITCHING ADAPTER	
Trade Mark		
Manufacturer	Same as applicant	
Model/Type reference	CZH015xxxxyymmWH, CZH015xxxxyymmWHL, CZH015xxxxyymmWHG, CZH015xxxxyymmWHLG, CZH015xxxxyymmWP, CZH015xxxxyymmWPL, CZH015xxxxyymmWPG, CZH015xxxxyymmWPLG, CZH015xxxxyymmWM, CZH015xxxxyymmWML, CZH015xxxxyymmWMG, CZH015xxxxyymmWMLG, CZH015xxxxyymmWF, CZH015xxxxyymmWFL, CZH015xxxxyymmWFG, CZH015xxxxyymmWFLG, CZH015xxxxyyTRWM, CZH015xxxxyyTRWML, CZH015xxxxyyTRWF, CZH015xxxxyyTRWFL, CZH015xxxxyymmWQ, CZH015xxxxyymmWQL, CZH015xxxxyymmWQG, CZH015xxxxyymmWQLG, CZH015xxxxyyTRWQ, CZH015xxxxyyTRWQL, CZH015xxxxyyEUWAa, CZH015050yyymmUM, CZH015050yyymmUGa (xxx, yyy, mm and a are variables, see 'General product information and other remarks' for details of model description.)	
Ratings	Input: 100-240VAC, 50/60Hz, 0.5A Max Output: See 'General product information and other remarks' for details	
Responsible Testing Laboratory (as applicable), testing procedure and testing location(s):		
<input checked="" type="checkbox"/>	Testing Laboratory:	TÜV SÜD Certification and Testing (China) Co., Ltd. Shenzhen Branch
	Testing location/ address	Building 12 & 13, Zhiheng Wisdomland Business Park, Guankou Erlu, Nantou, Nanshan District, Shenzhen, Guangdong 518052, China
	Tested by (name, function, signature)	Phil Quan (Project Handler) 
	Approved by (name, function, signature) ...	Kevin Chen (Designated Reviewer) 
		
<input type="checkbox"/>	Testing procedure: CTF Stage 1:	
	Testing location/ address	
	Tested by (name, function, signature)	
	Approved by (name, function, signature) ...	
<input type="checkbox"/>	Testing procedure: CTF Stage 2:	
	Testing location/ address	
	Tested by (name + signature)	
	Witnessed by (name, function, signature) ...	

Approved by (name, function, signature)... :		
<input type="checkbox"/>	Testing procedure: CTF Stage 3:	
<input type="checkbox"/>	Testing procedure: CTF Stage 4:	
Testing location/ address.....:		
Tested by (name, function, signature).....:		
Witnessed by (name, function, signature)..:		
Approved by (name, function, signature)....:		
Supervised by (name, function, signature) :		

List of Attachments (including a total number of pages in each attachment):									
Attachment No. 1: 2 pages of European Group and National Difference according to EN 61558-2-16:2009+A1:2013.									
Attachment No. 2: 1 page of Germany National Differences for plug-in power supplies according to EK1 557-13.									
Attachment No. 3: 1 page of PAH risk assessment report.									
Attachment No. 4: 51 pages of plug test report.									
Attachment No. 7: 93 pages of photos document.									
Summary of testing:									
<p>Tests performed (name of test and test clause):</p> <p>The submitted samples were tested and found to comply with the requirements of:</p> <ul style="list-style-type: none"> ➤ Electrical safety <ul style="list-style-type: none"> - EN IEC 61558-1:2019 - EN 61558-2-16:2009+A1:2013 ➤ PAH risk assessment <ul style="list-style-type: none"> - AfPS GS 2019:01 PAK <p>- The below models were selected for tests:</p> <table border="1" style="width: 100%; border-collapse: collapse;"> <thead> <tr> <th style="width: 50%;">Model name</th> <th style="width: 50%;">Performed test</th> </tr> </thead> <tbody> <tr> <td>CZH015420044EUWH</td> <td>Full test</td> </tr> <tr> <td>CZH015310060EUWH, CZH015178101EUWH, CZH015100150EUWH, CZH015050260EUWH</td> <td>Clause 11, Clause 12, Clause 14, Clause 15, Clause 26</td> </tr> <tr> <td>CZH015420044EUWHL</td> <td>Clause 9, Clause 11, Clause 12, Clause 14, Clause 18, Clause 17, Clause 15, Clause 16,</td> </tr> </tbody> </table>	Model name	Performed test	CZH015420044EUWH	Full test	CZH015310060EUWH, CZH015178101EUWH, CZH015100150EUWH, CZH015050260EUWH	Clause 11, Clause 12, Clause 14, Clause 15, Clause 26	CZH015420044EUWHL	Clause 9, Clause 11, Clause 12, Clause 14, Clause 18, Clause 17, Clause 15, Clause 16,	<p>Testing location:</p> <p>TÜV SÜD Certification and Testing (China) Co., Ltd. Shenzhen Branch Building 12 & 13, Zhiheng Wisdomland Business Park, Guankou Erlu, Nantou, Nanshan District, Shenzhen, Guangdong 518052, China</p>
Model name	Performed test								
CZH015420044EUWH	Full test								
CZH015310060EUWH, CZH015178101EUWH, CZH015100150EUWH, CZH015050260EUWH	Clause 11, Clause 12, Clause 14, Clause 15, Clause 26								
CZH015420044EUWHL	Clause 9, Clause 11, Clause 12, Clause 14, Clause 18, Clause 17, Clause 15, Clause 16,								

	Clause 19, Clause 22	
CZH015310060EUWHL, CZH015178101EUWHL, CZH015100150EUWHL, CZH015050260EUWHL	Clause 11, Clause 12, Clause 14, Clause 15, Clause 17, Clause 18, Clause 26	
CZH015050260EUWHLG	Clause 14, Clause 15, Clause 16, Clause 17, Clause 18, Clause 19, Clause 22, Clause 26, Clause 28	
CZH015050260EUWP, CZH015050260EUWPL	Clause 9, Clause 15, Clause 16, Clause 17, Clause 18, Clause 22, Clause 26	
CZH015420044EUWF	Clause 9, Clause 11, Clause 12, Clause 14, Clause 15, Clause 16, Clause 17, Clause 18, Clause 19, Clause 26	
CZH015420044EUWML, CZH015420044EUWFL, CZH015420044TRWM, CZH015420044TRWF, CZH015420044TRWML, CZH015420044TRWFL	Clause 16, Clause 17, Clause 18, Clause 19, Clause 26	
CZH015050250EUUM	Clause 9, Clause 11, Clause 12, Clause 14, Clause 15, Clause 16, Clause 17, Clause 18, Clause 19, Clause 26, Clause 28	
CZH015420044EUWA	Clause 9, Clause 11, Clause 12, Clause 14, Clause 15, Clause 16,	

	Clause 17, Clause 18, Clause 19, Clause 22	
CZH015310060EUWA, CZH015178101EUWA, CZH015100150EUWA, CZH015050260EUWA	Clause 11, Clause 12, Clause 14, Clause 15, Clause 26	
CZH015420044EUWQ	Clause 9, Clause 11, Clause 12, Clause 14, Clause 15, Clause 16, Clause 17, Clause 18, Clause 19, Clause 22	
CZH015310060EUWQ, CZH015178101EUWQ, CZH015100150EUWQ, CZH015050260EUWQ	Clause 11, Clause 12, Clause 14, Clause 15, Clause 26	
CZH015420044EUWQG	Clause 14, Clause 15, Clause 16, Clause 17, Clause 18, Clause 19, Clause 22, Clause 26, Clause 28	
CZH015420044TRWQ, CZH015420044EUWQ, CZH015420044EUWQL, CZH015420044EUWQG, CZH015420044EUWQLG	Clause 9, Clause 16, Clause 17, Clause 18, Clause 19, Clause 22	
CZH015050300EUUG	Clause 9, Clause 11, Clause 12, Clause 14, Clause 15, Clause 16, Clause 17, Clause 18, Clause 19, Clause 26, Clause 28	
CZH015420044BSWH, CZH015420044BSWP, CZH015420044BSWM, CZH015420044BSWF, CZH015420044BSWHL, CZH015420044BSWPL, CZH015420044BSWML, CZH015420044BSWFL,	Clause 16, Clause 19, Clause 26	

CZH015420044BSWHG, CZH015420044BSWPG, CZH015420044BSWMG, CZH015420044BSWFG, CZH015420044BSWHLG, CZH015420044BSWPLG, CZH015420044BSWMLG, CZH015420044BSWFLG, CZH015420044BSWQ, CZH015420044BSWQL, CZH015420044BSWQG, CZH015420044BSWQLG, CZH015420044BSUM CZH015420044TRWQ, CZH015420044TRWL		
---	--	--

Summary of compliance with National Differences (List of countries addressed):
See the attachment No. 1 to No. 2 of National and Group Differences for details.
 The product fulfils the requirements of EN IEC 61558-1:2019, EN 61558-2-16:2009+A1:2013.

Copy of marking plate:
The artwork below may be only a draft. The use of certification marks on a product must be authorized by the respective NCBs that own these marks.

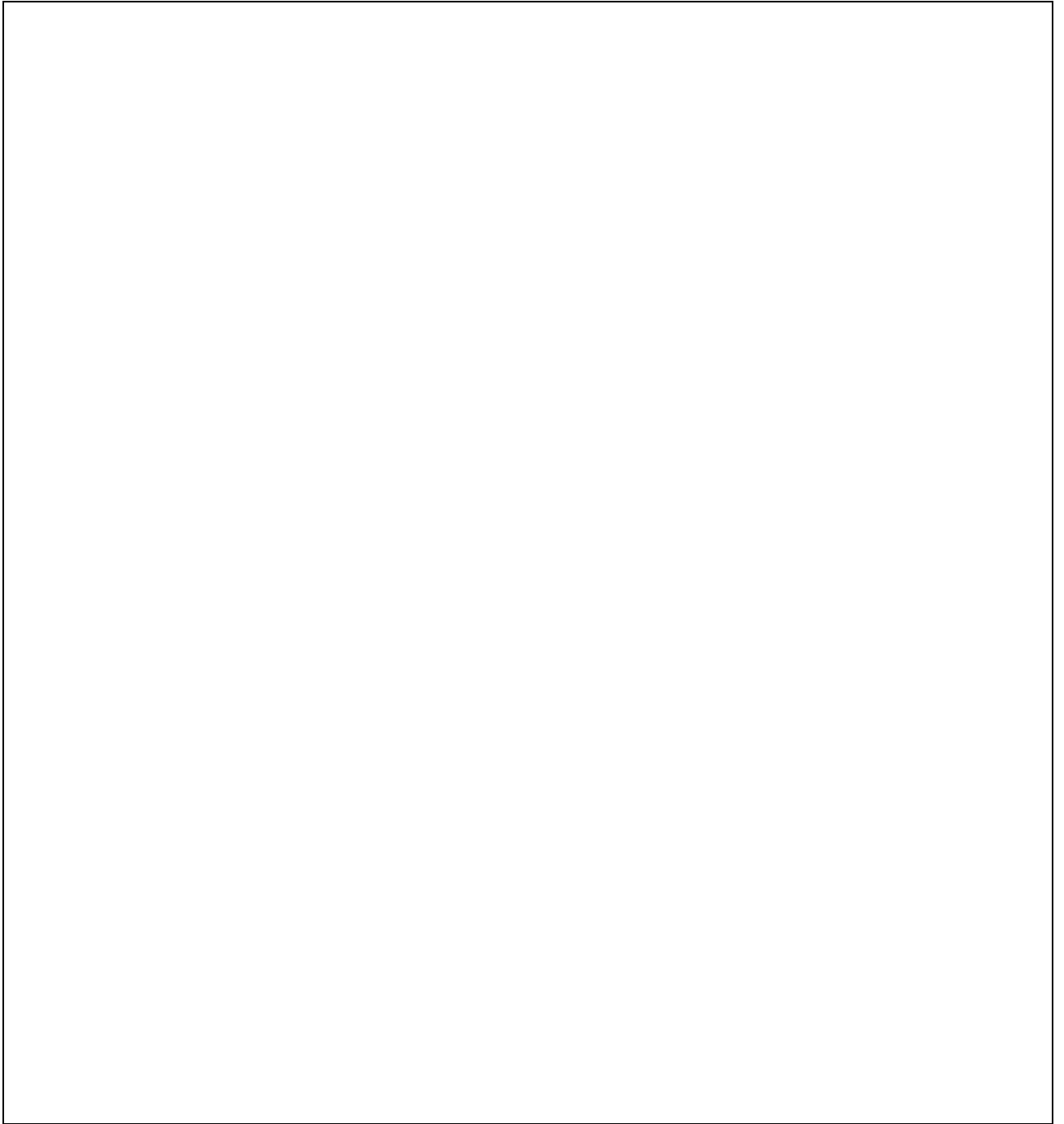

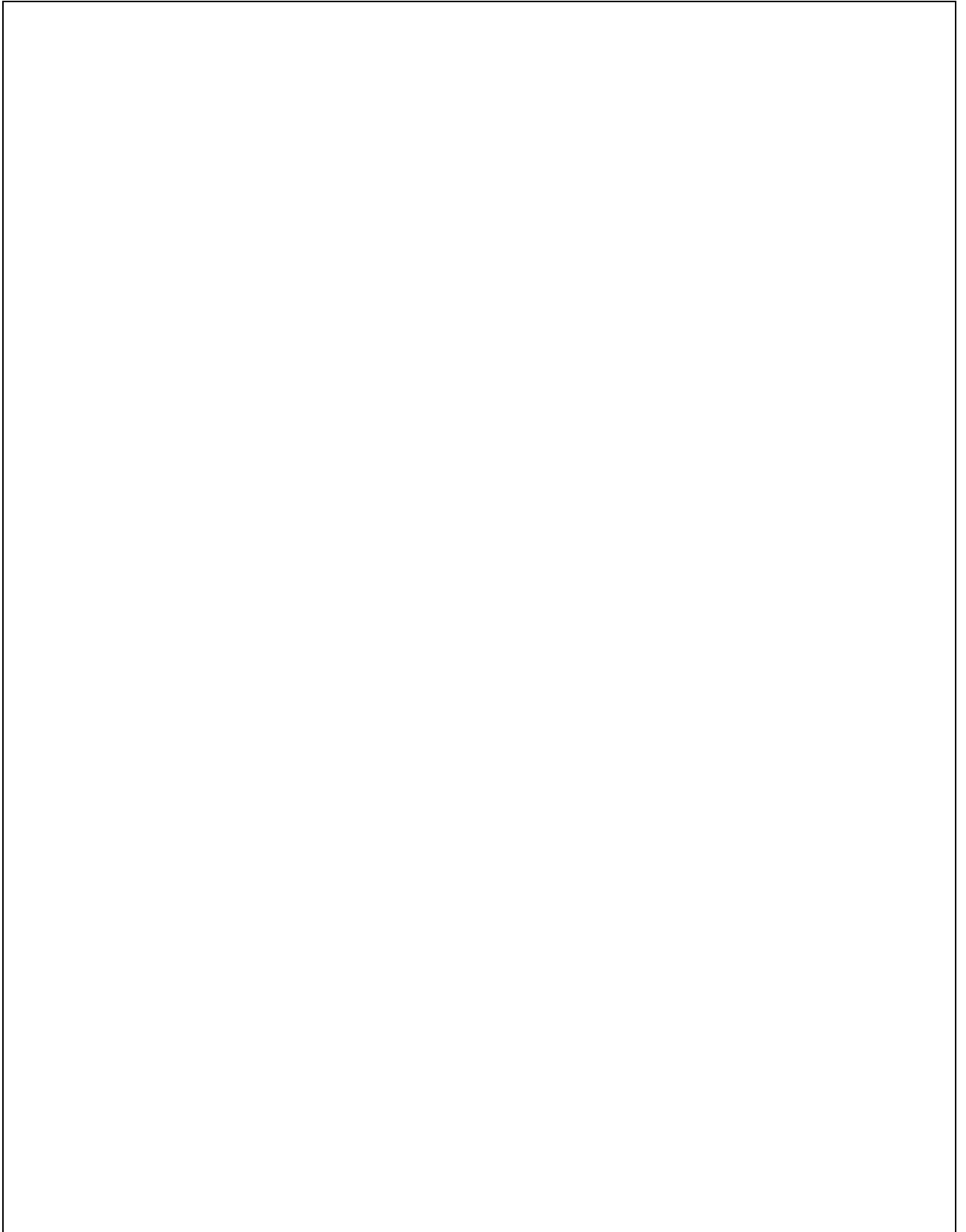

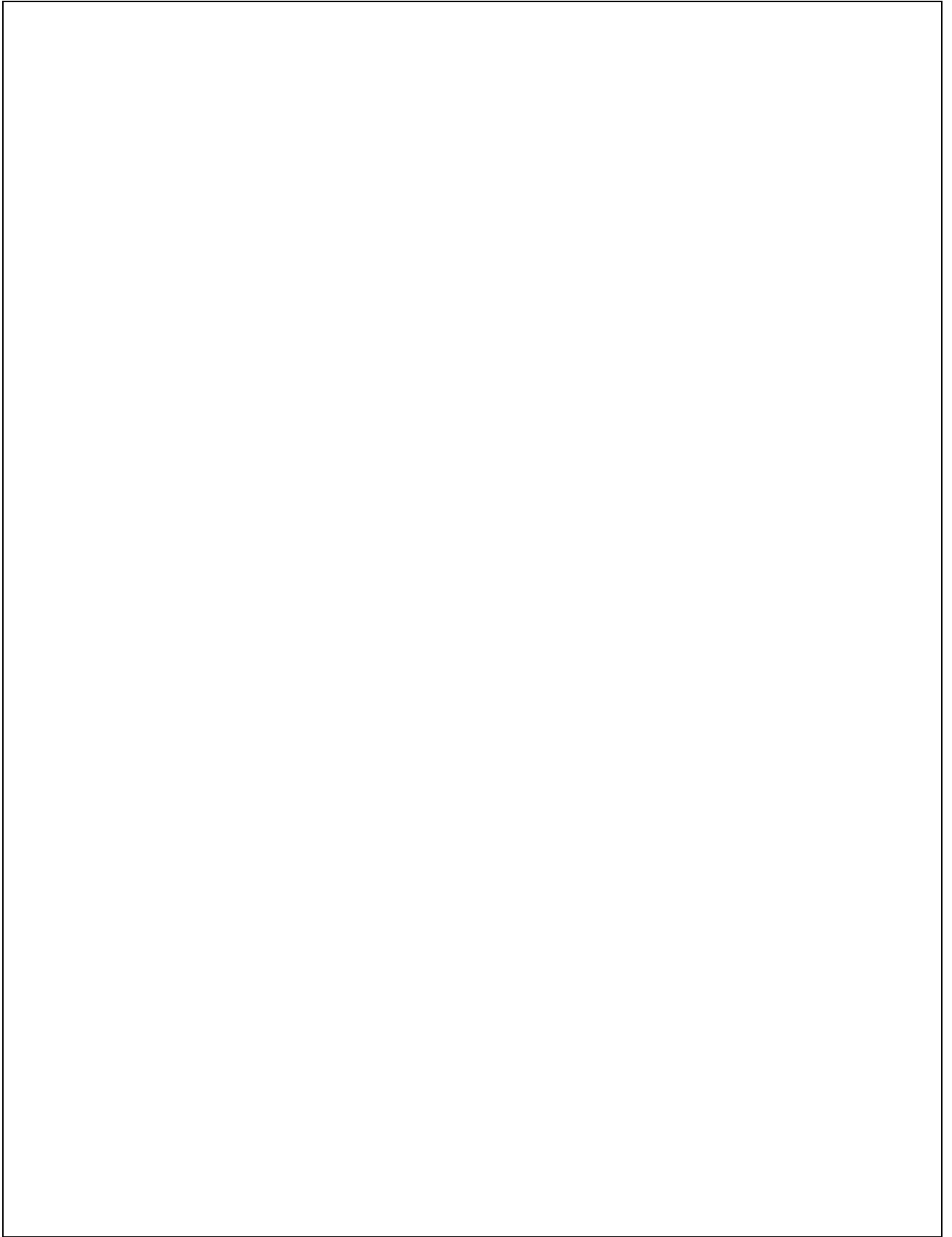

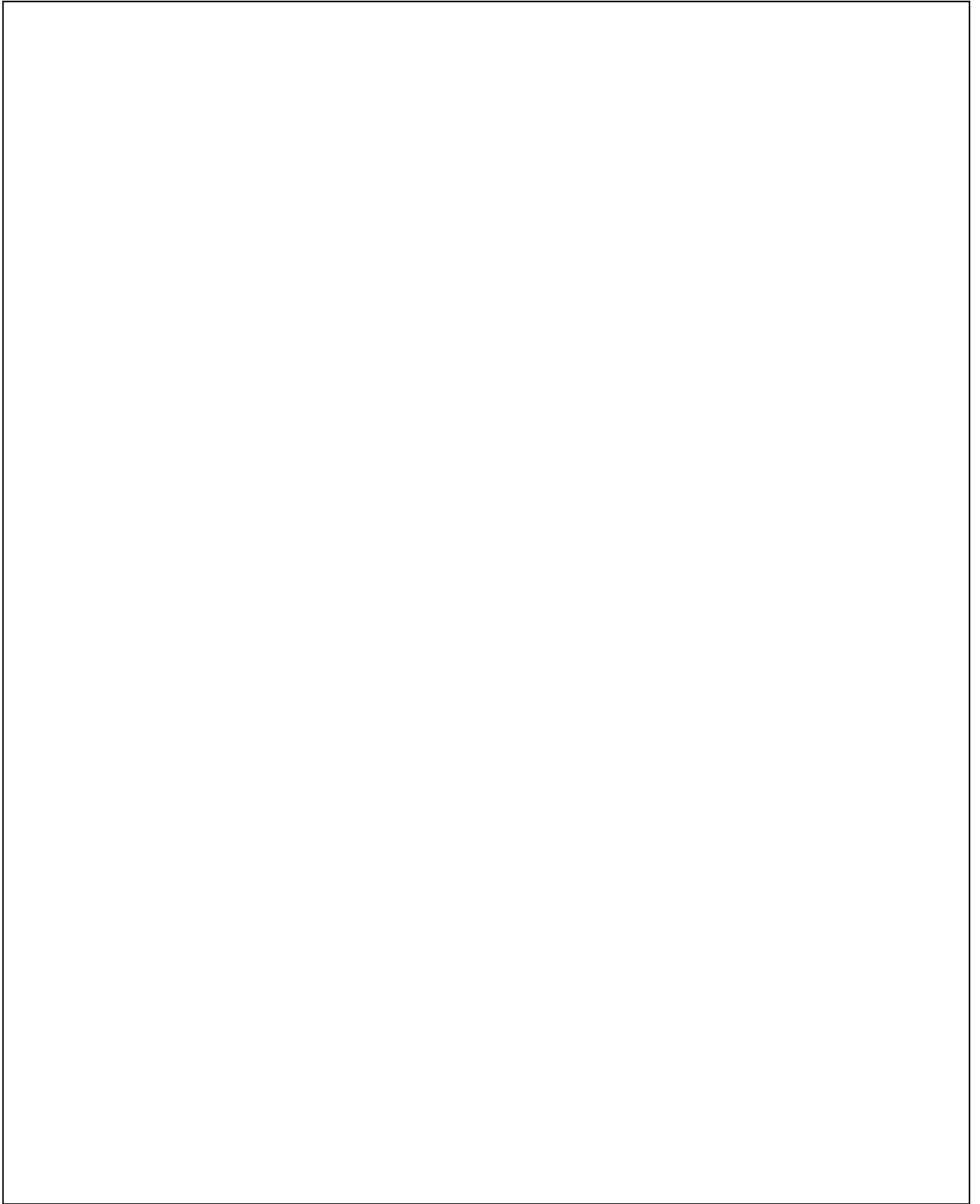

Importer:xxx...
Importer Address:xxx...

The importer information should be marked in label when this product import to European Market.

Remark:









- 1). Representative labels as above, the others are identical except for model designation and output ratings.
- 2). The height dimension of CE & UKCA mark should not less than 5mm, the height dimension of WEEE symbol should not less than 7mm.
- 3). WWYY is date code, WW means weeks, YY means years.



- 4).  symbol only used for models with mains plug complying with EN 50075 (IEC plug type C).
- 5). According to the EU directives which have been aligned with EU NLF (new legislative framework), both of manufacturer and importer's name and address shall be affixed on the product or, where that is not possible, on its packaging or in a document accompanying the product before the product is placed on the EU market.
- 6). According to the German product safety law (ProdSG), the name and address of manufacturer (an EU-based importer or authorized representative if the manufacturer is not based in EU) shall be affixed on the product or, where that is not possible, on its packaging or in a document accompanying the product before the product is placed on the EU market.

Test item particulars : SWITCHING ADAPTER				
Classification of installation and use : Class II equipment and Portable use				
Supply Connection : Direct plug-in				
Possible test case verdicts:				
- test case does not apply to the test object : N/A				
- test object does meet the requirement : P (Pass)				
- test object does not meet the requirement : F (Fail)				
Testing				
Date of receipt of test item : 2022-09-26				
Date (s) of performance of tests : From 2022-09-26 to 2023-03-20				
General remarks:				
"(See Enclosure #)" refers to additional information appended to the report. "(See appended table)" refers to a table appended to the report.				
Throughout this report a <input type="checkbox"/> comma / <input checked="" type="checkbox"/> point is used as the decimal separator.				
When differences exist; they shall be identified in the General product information section.				
Name and address of factory (ies) : Same as applicant				
General product information and other remarks:				
Product Description –				
1. 1. These switching adapters are direct plug-in type appliances with class II construction, which designed to supply power for general use, for indoor use only.				
2. The maximum operating ambient temperature is 35°C.				
3. Clearance was evaluated for operating altitude up to 2000m above sea level.				
4. The top enclosure is sealed with bottom enclosure by a rim and ultrasonic welding.				
5. The EU and UK portions of these of these switching adapters have been evaluated according to relevant standard as following, other plug portions shall be evaluated during the national approval:				
- EU plug: EN 50075;				
- BS plug with ISOD: BS 1363.				
6. There are two constructions for Y-capacitor bridged primary and secondary circuit as following:				
-Two Y-capacitors CY2 and CY1 used, or				
-One Y-capacitor CY3 used.				
When only one Y1-cap is connected between primary circuit and secondary circuit, the further assessment shall be implemented in conformity with the requirement of end product.				
Model Differences –				
1. The primary line choke L1 (model AL0510 or DR8*10) is alternative to LF1 (model EE8.3) used for all models except CZH015050yyymmUGa, only primary line choke L1 (model AL0510) is used for models CZH015050yyymmUGa.				
2. The secondary diode can be D3 alternative to D3A used, or can be D3A alternative to D3A1 used for all models except CZH015050yyymmUGa, refer to "Table – PCB Layout" for details.				
3. The components U3, U2, C11, R20 is optional used for models CZH015050yyymmUGa.				
4. All models are identical to each other except for the plugtype, the connecting methods between the plug pins and PCB, the enclosure construction, secondary circuit diagram, PCB Layout, output rating, transformer secondary windings, some secondary electrical components and the model name.				
5. There are two connecting methods between the plug pins and PCB: the primary lead wire used, or elastic metal sheet used, refer to "Table – Enclosure construction" for details.				
6. Model list				
Model No.	Rated output	Rated output	Max. output	Transformer (T1)

	voltage (VDC)	current (A)	power (W)	type (x=0-9 or A-Z or Blank)
CZH015xxxxxyymmWH,	5.0-7.5	0.01-2.60	13.0	CZH015-05V-Ax
CZH015xxxxxyymmWHL,	7.6-11.5	0.01-1.50	15.0	CZH015-09V-Ax
CZH015xxxxxyymmWHG,	11.6-16.5	0.01-1.25	15.0	CZH015-12V-Ax
CZH015xxxxxyymmWHLG,	16.6-23.0	0.01-1.01	18.0	CZH015-20V-Ax
CZH015xxxxxyymmWP,	23.1-30.0	0.01-0.72	18.0	CZH015-30V-Ax
CZH015xxxxxyymmWPL,	30.1-42.0	0.01-0.60	18.6	CZH015-42V-Ax
CZH015xxxxxyymmWPG,				
CZH015xxxxxyymmWPLG,				
CZH015xxxxxyymmWM,				
CZH015xxxxxyymmWML,				
CZH015xxxxxyymmWMG,				
CZH015xxxxxyymmWMLG,				
CZH015xxxxxyymmWF,				
CZH015xxxxxyymmWFL,				
CZH015xxxxxyymmWFG,				
CZH015xxxxxyymmWFLG,				
CZH015xxxxxyyyTRWM,				
CZH015xxxxxyyyTRWML,				
CZH015xxxxxyyyTRWF,				
CZH015xxxxxyyyTRWFL,				
CZH015xxxxxyyyEUWAa,				
CZH015xxxxxyymmWQ,				
CZH015xxxxxyymmWQL,				
CZH015xxxxxyymmWQG,				
CZH015xxxxxyymmWQLG,				
CZH015xxxxxyyyTRWQ,				
CZH015xxxxxyyyTRWQL				
CZH015050yyymmUM	5.0	0.01-2.50	12.5	CZH015-05V-Ax
CZH015050yyymmUGa	5.0	0.01-3.00	15.0	CZH015-05V-A
<p>Remarks:</p> <p>xxx=050-420, stands for the rated output voltage from 5.0VDC to 42.0VDC, in step of 0.1V; yyy=001-300, stands for the rated output current from 0.01A to 3.0A, in step of 0.01A; mm=BS or EU, stands for different the plug type, BS means British plug, EU means European plug; a=A-Z or blank, stands for different customer code for marketing purpose; The suffixes for above models (except CZH015xxxxxyyyEUWAa, CZH015050yyymmUGa) as following: W means the models with output wire, U means the models with USB output; TR means the models with detachable plug, L means the models with LED indicator, G means the models with potting material. H, P, M, F, A, Q means for the different enclosure construction, refer to "Table – Enclosure construction" for details.</p>				
7. Table – Enclosure construction				
Model	Enclosure shape	PCB Layout type*	The connecting methods between the plug pins and PCB	
CZH015xxxxxyymmWH, CZH015xxxxxyymmWHG		Type A, Type B	Primary lead wire or elastic metal sheet	

CZH015xxxxxyymmWP, CZH015xxxxxyymmWPG		Type A, Type B	Primary lead wire or elastic metal sheet
CZH015xxxxxyymmWHL, CZH015xxxxxyymmWHLG		Type B	Primary lead wire or elastic metal sheet
CZH015xxxxxyymmWPL, CZH015xxxxxyymmWPLG		Type B	Primary lead wire or elastic metal sheet
CZH015xxxxxyymmWM, CZH015xxxxxyymmWMG		Type C, Type G	Primary lead wire or elastic metal sheet
CZH015050yyymmUM		Type D	Primary lead wire or elastic metal sheet
CZH015xxxxxyymmWF, CZH015xxxxxyymmWFG		Type C	Primary lead wire or elastic metal sheet
CZH015xxxxxyymmWML, CZH015xxxxxyymmWMLG		Type C, Type G	Primary lead wire or elastic metal sheet
CZH015xxxxxyymmWFL, CZH015xxxxxyymmWFLG		Type C	Primary lead wire or elastic metal sheet
CZH015xxxxyyTRWM		Type C, Type G	Primary lead wire

			
<p>CZH015xxxxxyyTRWF</p>	 	<p>Type C, Type G</p>	<p>Primary lead wire</p>
<p>CZH015xxxxxyyTRWML</p>	 	<p>Type C</p>	<p>Primary lead wire</p>
<p>CZH015xxxxxyyTRWFL</p>	 	<p>Type C</p>	<p>Primary lead wire</p>
<p>CZH015xxxxyyymmWQ, CZH015xxxxyyymmWQG</p>		<p>Type A</p>	<p>Elastic metal sheet</p>

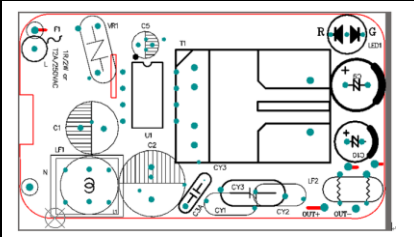
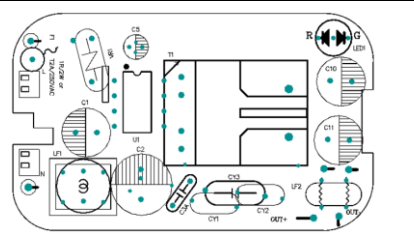
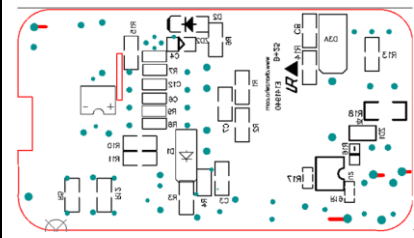
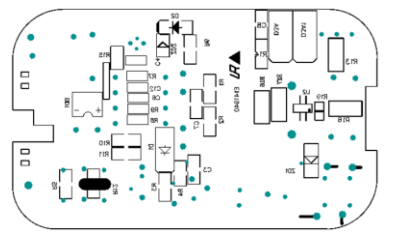
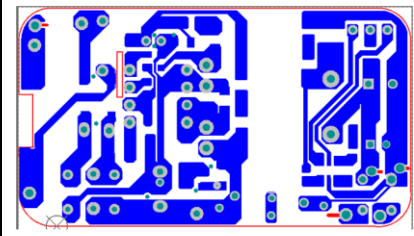
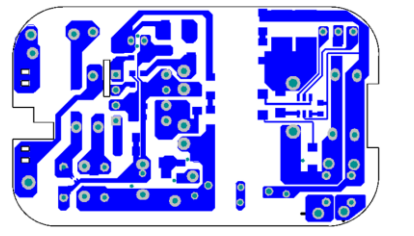
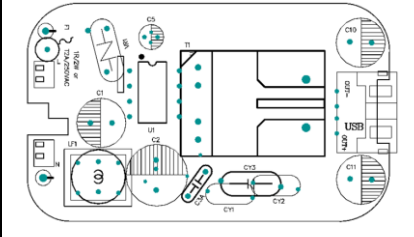
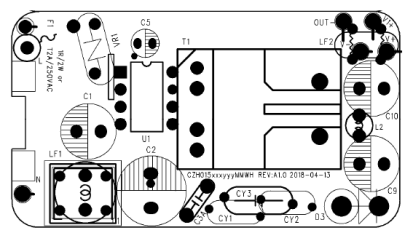
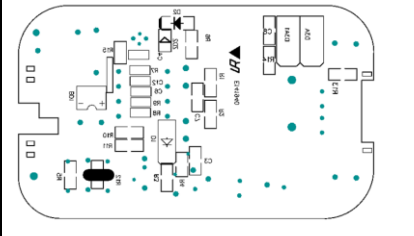
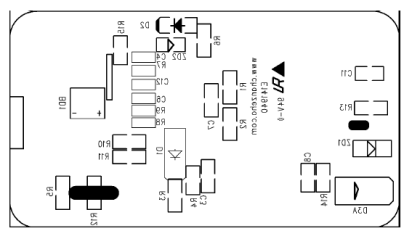
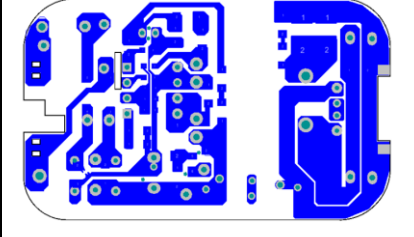
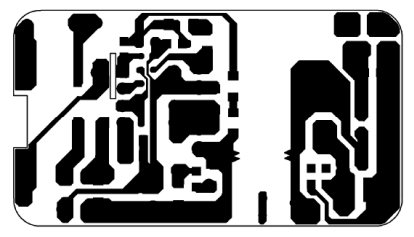
	
	
	
<p>PCB type D Used for models CZH015050yyymmUM</p>	<p>PCB type A Used for models CZH015xxxxyymmWH, CZH015xxxxyymmWP, CZH015xxxxyymmWHG, CZH015xxxxyymmWPG, CZH015xxxxyymmWQ, CZH015xxxxyymmWQG, CZH015xxxxyymmWQL, CZH015xxxxyymmWQLG, CZH015xxxxyyTRWQ, CZH015xxxxyyTRWQL</p>
	
	
	
<p>PCB type E Used for models CZH015xxxxyyEUWAa</p>	<p>PCB type F Used for models CZH015050yyymmUGa</p>

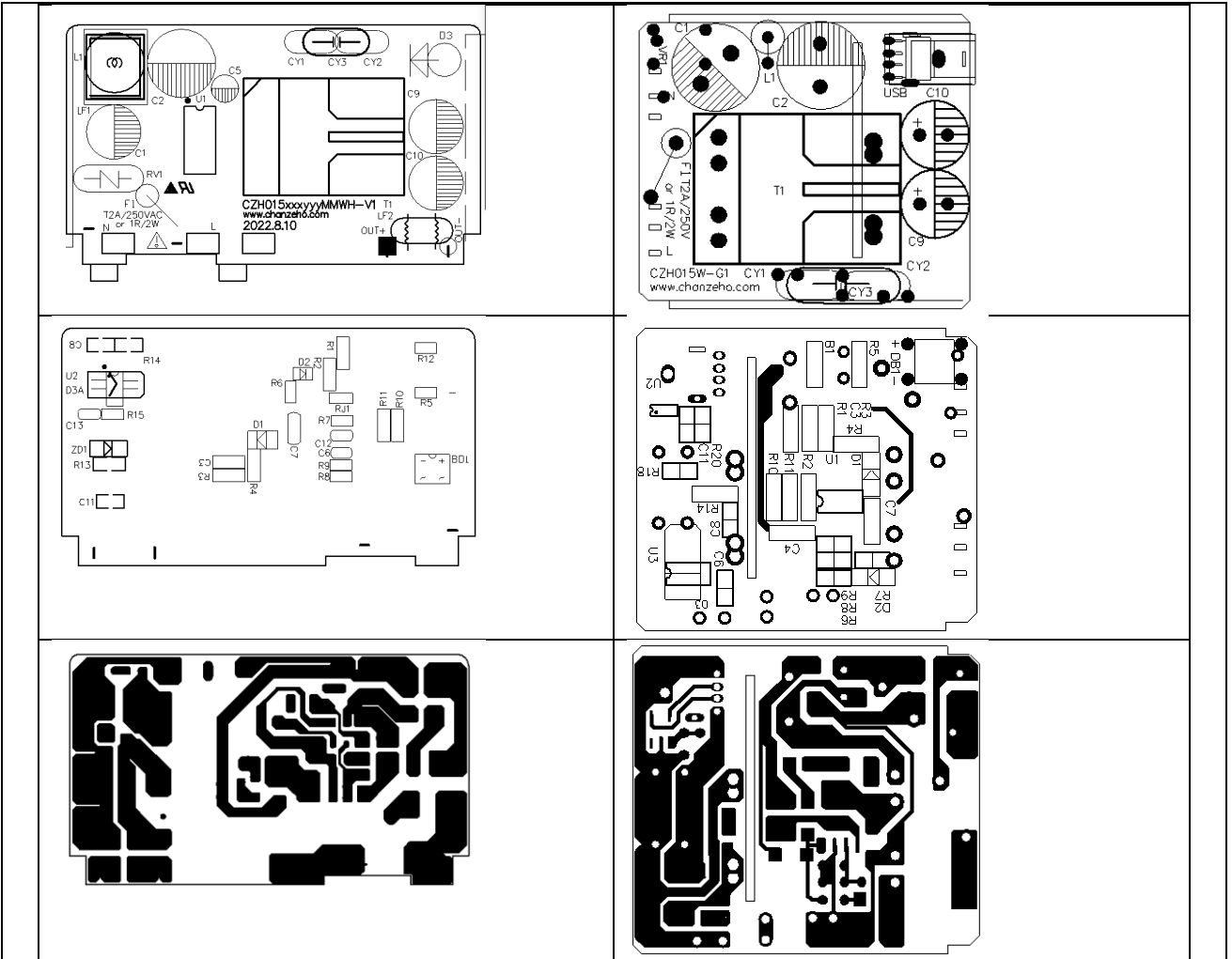





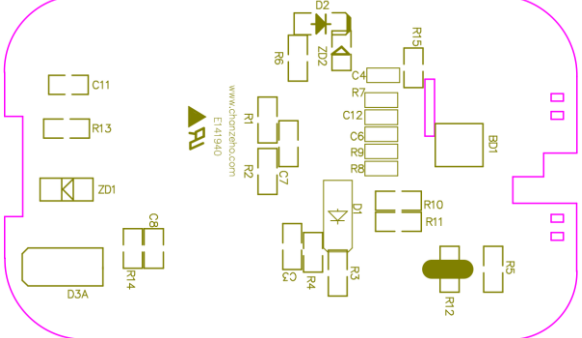
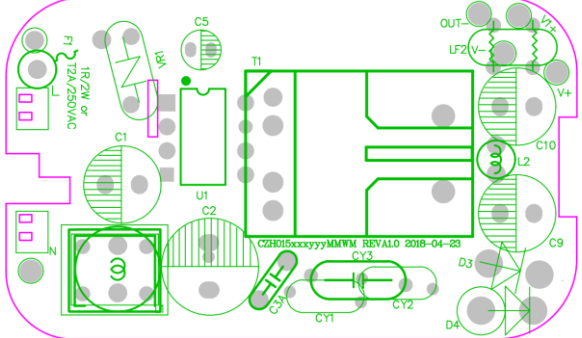

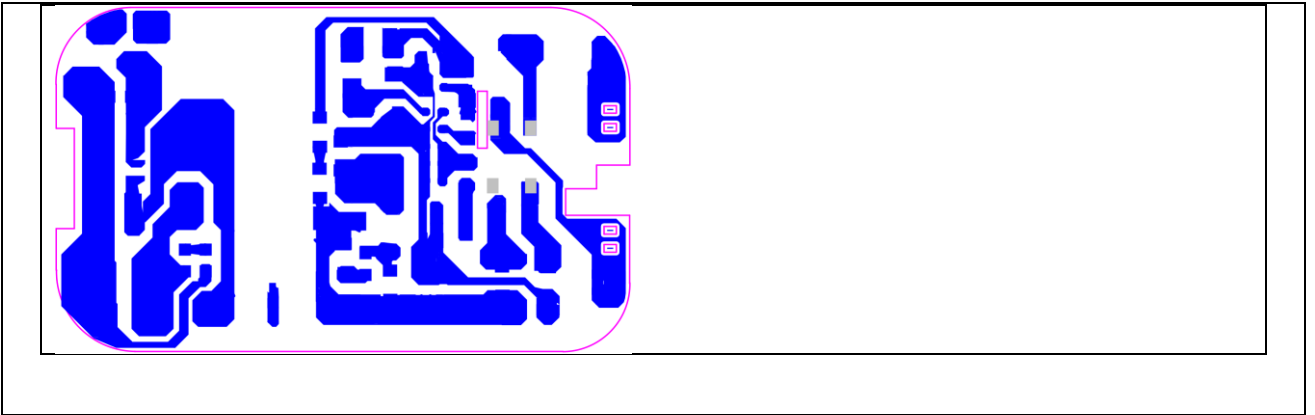
PCB type G





Used for models CZH015xxxxyyymmWM, CZH015xxxxyyymmWF, CZH015xxxxyyymmWVG, CZH015xxxxyyymmWFG, CZH015xxxxyyTRWM, CZH015xxxxyyTRWF







IEC 61558-2-16			
Clause	Requirement + Test	Result - Remark	Verdict
8	MARKING AND OTHER INFORMATION		P
8.1	Transformer marked with (for symbols see Table 1):		P
	a) rated supply voltage or voltage range (V)	100-240V~	P
	b) rated output voltage (V)	See rating label and model list	P
	c) rated output (VA, kVA or W)	See rating label and model list	P
	d) rated output current (A)	See rating label and model list	P
	e) rated frequency (Hz)	50/60Hz	P
	f) rated power factor (if not 1)		N/A
	g) symbol AC for alternating current, or DC for direct current-output	~ for input and  for output	P
	h) symbol for electrical function (according to one or more part's 2) in addition with the symbol for SMPS (IEC 61558-2-16:09)	Symbol  and  used	P
	i) manufacturer's name or trademark or name of the responsible vendor	Manufacturer's name is shown	P
	j) model or type reference	See rating label and model list	P
	k) vector group according to IEC 60076 for three-phase transformer		N/A
	l) symbol for Class II		P
	symbol for Class III		N/A
	m) index IPXX if other than IP00	IP20	P
	n) rated max. ambient temperature t_a (if not 25 °C)	35°C	P
	o) rated minimum ambient temperature t_{amin} , if <10° C and if a temperature sensitive device is used		N/A
	p) p) duty cycle, if any, unless the operating time is limited by the construction of the transformer or corresponds to the operating conditions specified in the relevant part 2		N/A
	q) symbol for overvoltage category, if other than OVC II;		N/A
	r) transformers used with forced air cooling shall be marked with "AF" in m/s		N/A
	s) Information from the manufacturer to the purchaser (data sheet):		P
	– short-circuit voltage (% rated supply voltage) for stationary transformers > 1000 VA		N/A
	– electrical function of the transformer		P
	– All markings except those under i) and j) may be illustrated as QR Code according ISO/IEC 18004.		N/A

IEC 61558-2-16			
Clause	Requirement + Test	Result - Remark	Verdict
	t) symbol indicating the maximum altitude of installation, if higher than 2 000 m.		N/A
8.2	Marking for transformers IP00 or for associated transformers: type and trademark, instruction sheets		N/A
8.3	Adjusted voltage easily and clearly discernible		N/A
8.4	For each tapping or winding: rated output voltage and rated output		N/A
	necessary connections clearly indicated		N/A
8.5	For non-short-circuit proof transformers or non-inherently short-circuit proof transformers:		N/A
	Rated current (A or mA) and symbol for time current characteristics of the fuses for non-inherently short-circuit proof transformer with incorporated fuses and non-short-circuit proof transformer	Non-replaceable current fuse or fusible resistor used	N/A
	Manufacturer's model or type reference and rating of the device for non-inherently short-circuit proof transformers with incorporated replaceable protective device (other than fuses)	See above	N/A
	Construction sheet for transformers with replaceable protective device (other than fuses) information with information about the replacement.		N/A
8.6	Terminals for neutral: "N"		N/A
	Terminal for protective earth marked with earthing symbol		N/A
	Identification of input terminals:		N/A
	Identification of output terminals:		N/A
	Symbol for any point/terminal in connection with frame or core		N/A
8.7	Indication for correct connection	Evident from the design of the transformer	N/A
8.8	Instruction sheet for type X, Y, Z attachments	Type Z attachment for output cord	P
8.9	Transformer for indoor use shall be marked with the relevant symbol.		P
8.10	Symbol for Class II construction not confused with maker's name or trademark.		P
	Class II transformer with parts to be mounted – delivered with all parts for class II after mounting.		N/A
	Symbol for class II transformer placed on the part which provides class II.		N/A
8.11	Correct symbols:		P
	Volts	V	P
	Amperes	A	P

IEC 61558-2-16			
Clause	Requirement + Test	Result - Remark	Verdict
	Volt amperes (or volt-amperes reactive for reactors)		N/A
	Watts	W	P
	Hertz	Hz	P
	Input	PRI	N/A
	Output	SEC	N/A
	Direct current		P
	Neutral		N/A
	Single-phase a.c.		P
	Three-phase a.c.		N/A
	Three-phase and neutral a.c.		N/A
	Power factor		N/A
	Class II construction		P
	Class III construction		N/A
	Equipment of overvoltage category I		N/A
	Equipment of overvoltage category II		N/A
	Equipment of overvoltage category III		N/A
	Equipment of overvoltage category IV		N/A
	Fuse-link		N/A
	Rated max. ambient temperature	$t_a=35^{\circ}\text{C}$	P
	Rated minimum ambient temperature		N/A
	Rated minimum temperature		N/A
	Frame or core terminal		N/A
	Protective earth		N/A
	IP number	IP20	P
	Earth (ground for functional earth)		N/A
	For indoor use only		P
	To indicate that the appliance is intended to be usable up to the maximum altitude 3 000 m.		N/A
	To indicate that the power supply unit shall not be used, if pins of the plug part are damaged.	 for models with mains plug complying with EN 50075 (IEC plug type C) only	P
	Additional Symbols (IEC 61558-2-16:09)		P
	SMPS incorporating a Fail-safe separating transformer		N/A

IEC 61558-2-16			
Clause	Requirement + Test	Result - Remark	Verdict
	SMPS incorporating a Non-short-circuit-proof separating transformer		N/A
	SMPS incorporating a Short-circuit-proof separating transformer (inherently or non-inherently)		N/A
	SMPS incorporating a Fail-safe isolating transformer		N/A
	SMPS incorporating a Non-short-circuit-proof isolating transformer		N/A
	SMPS incorporating a Short-circuit-proof isolating transformer (inherently or non-inherently)		N/A
	SMPS incorporating a Fail-safe safety isolating transformer		N/A
	SMPS incorporating a Non-short-circuit-proof safety isolating transformer		N/A
	SMPS incorporating a Short-circuit-proof safety isolating transformer (inherently or non-inherently)		P
	SMPS incorporating a Fail-safe auto-transformer		N/A
	SMPS incorporating a Non-short-circuit proof auto-transformer		N/A
	SMPS incorporating a Short-circuit proof auto-transformer (inherently or non-inherently)		N/A
	SMPS (Switch mode power supply unit)		P
8.12	Number, letters or other visual means for different positions of regulating devices and switches		N/A
	OFF position indicated by number 0		N/A
	Greater output, input etc. indicated by higher number		N/A
8.13	Marking not on screws or other easily removable parts		P
	Marking clearly discernible (transformer ready for use)		P
	Marking for terminals clearly discernible if necessary after removal of the cover		N/A
	Marking for terminals: no confusion between input and output		N/A
	Marking for interchangeable protective devices positioned adjacent to the base		N/A

IEC 61558-2-16			
Clause	Requirement + Test	Result - Remark	Verdict
	Marking for interchangeable protective devices clearly discernible after removal of cover and protective device		N/A
8.14	Visible information (symbols) shall be provided, when it is necessary to take special precautions for installation, transportation or use (in the catalogue, data sheet, instruction sheet or packaging):		P
	For non-inherently short-circuit proof transformers with non-self-resetting or non-replaceable devices (weak-point, thermal link): The device cannot be reset or replaced		P
	For transformers generating a protective earth conductor current greater than 10 mA (see also cl. 18.5.2): The installation shall be made according to the wiring rules.		N/A
	For stationary transformers exceeding 1000 VA: The short circuit voltage in % of the rated supply voltage		N/A
	For all transformers the electrical function: An information about the electrical function of the transformer (e.g. inherently short circuit proof safety isolating transformer)		P
	the limiting temperature of the winding under abnormal conditions which shall be respected when the transformer is built into an appliance as information for appliance design;		N/A
	For transformers with more than one output winding, not for series or parallel connection		N/A
	– an information in the instruction sheet: the transformer is not intended for series/parallel connection		N/A
	For IP00-transformers the test of 27.2 is not performed. The result may be affected by the enclosure in the final application.		N/A
8.15	Marking durable and easily legible		P
8.16	Portable transformers with integrated plugs complying with EN 50075 (IEC plug type C), shall use the symbol IEC 60417-6352:2015-10. The instruction sheet of the plug in transformer shall contain the following information, or equivalent: if the pins of the plug parts are damaged, the plug-in power supply shall be scrapped.		P
9	PROTECTION AGAINST ELECTRIC SHOCK		P
9.1	General		P
9.2	Protection against contact with hazardous-live-parts		P
9.2.1	Determination of hazardous-live-parts		P

IEC 61558-2-16			
Clause	Requirement + Test	Result - Remark	Verdict
9.2.1.1	A live part is not a hazardous live part if:		P
	– it is separated from the supply by double or reinforced insulation and		P
	– the requirements of 9.2.1.2 or 9.2.1.3 are fulfilled		P
9.2.1.2	The touch voltage is ≤ 35 V(peak) a.c. or ≤ 60 Vd.c.	Max. 42.07Vd.c. (output terminal)	P
9.2.1.3	If the touch voltage is > 35 V (peak)a.c. or > 60 V d.c., the following requirements shall be fulfilled:		P
	The touch current shall not exceed:		P
	– for a.c. 0,7 mA (peak)	Max. 0.199mA peak (when CY2 and CY1 used condition); Max. 0.378mA peak (when CY3 used condition)	P
	– for d.c. 2,0 mA (see Annex J)		N/A
	In addition, when a capacitor is connected to live parts:		—
9.2.1.3.1	discharge: < 45 μ C (between 60 V and 15 kV)		P
9.2.1.3.2	energy: ≤ 350 mJ (voltage > 15 kV)		N/A
9.2.2	Transformers shall have an adequate protection against accessibility to hazardous live parts:		P
	The enclosure of class I and class II transformers gives an adequate protection against accidental contact with hazardous live parts.		P
	Class I transformers: accessible parts are separated from hazardous live parts by at least basic insulation.		N/A
	Class II transformers: no accessibility to basic insulation, or conductive parts separated from hazardous live parts by basic insulation.		P
	Hazardous live parts are not accessible after removal of detachable parts.		P
	Hazardous live parts are not accessible after removal of detachable parts except for:		N/A
	– lamps having caps larger B9 and E10		N/A
	– type D fuse holder		N/A
	IP00 transformers shall comply with the end product standard after incorporation in the end product.		N/A
	The insulating properties of lacquer, enamel, paper, cotton, oxide film on conductive parts and sealing compound shall not be considered as giving the required protection against accidental contact with hazardous-live-parts with the exception of fully insulated winding wire (FIW).		P

IEC 61558-2-16			
Clause	Requirement + Test	Result - Remark	Verdict
	Shafts, handles, operating levers, knobs are not hazardous life parts.		N/A
	Compliance is checked by inspection and by relevant tests according to IEC 60 529		P
	Class II transformers and Class II parts of Class I construction are tested with the test pin (fig. 3)		P
	Hazardous live parts shall not be touchable by test finger (fig. 4) with the exception of fully insulated winding wire (FIW).		P
	for Class II transformers: conductive parts separated by basic insulation from hazardous live parts not touchable by test finger		P
	hazardous live parts shall not be touchable with the test pin		P
9.2.3	Accessibility of non-hazardous live parts		P
	Non-hazardous live parts of the output circuit may be accessible if they are isolated from the input circuit by double or reinforced insulation and if the following conditions are fulfilled:		P
	– The no load output voltage is ≤ 35 V peak a.c. or ≤ 60 V ripple free d.c., both poles are accessible	Max. 42.07Vd.c. (output terminal)	P
	– The no load output voltage is > 35 V peak a.c. or > 60 V ripple free d.c. and ≤ 250 V a.c., only one pole may be accessible		N/A
9.3	Transformers with primary supply plug: 1 s after the interruption of the supply the voltage between the pins do not exceed 35 V (peak) a.c. or 60 V ripple free d.c.	No X-cap. used	N/A
	Transformers without a primary supply plug: 5 s after the interruption of the supply the voltage between the input terminals do not exceed 35 V (peak) a.c. or 60 V ripple free d.c.		N/A
	The following tests are required:		N/A
	If the nominal capacitance is $\leq 0,1$ μ F – no test is conducted.		N/A
	– 10 times switch the supply source on and off, or use a special equipment for to switch off at the most unfavourable electrical angle		N/A
	If the measured voltage is > 60 V ripple free d.c., the discharge must be ≤ 45 μ C.		N/A
10	CHANGE OF INPUT VOLTAGE SETTING		P
	Voltage setting not possible to change without a tool		N/A
	Different rated supply voltages:		N/A

IEC 61558-2-16			
Clause	Requirement + Test	Result - Remark	Verdict
	– indication of voltage for which the transformer is set, is discernible on the transformer.		N/A
10.101	A wide range of the input (100 V a. c. to 240 V a.c voltage is allowed (IEC 61558-2-16:09):	100-240V~	P
	– if the output voltages does not exceed the rated output voltage and		P
	– if the no-load voltage does not exceed the limits of output voltage deviation		P
11	OUTPUT VOLTAGE AND OUTPUT CURRENT UNDER LOAD		P
11.1	Difference from rated value (without rectifier; with rectifier):		P
	a) inherently short-circuit proof transformers with one rated output voltage for output voltage: a.c. $\leq 10\%$; d.c. $\leq 15\%$		N/A
	b) inherently short-circuit proof transformers with one more than 1 rated output voltage for highest output voltage: a.c. $\leq 10\%$; d.c. $\leq 15\%$		N/A
	c) idem for other output voltages: a.c. $\leq 15\%$; d.c. $\leq 20\%$		N/A
	d) other transformers for output voltages: a.c. $\leq 5\%$; d.c. $\leq 10\%$	(See appended table)	P
12	NO-LOAD OUTPUT VOLTAGE (see supplementary requirements in Part 2)		P
	Remark: with rectifier measuring on both sides of the rectifier		P
12.101	The no load output voltage shall not exceed (IEC 61558-2-16:09):		P
	– For SMPS incorporating separating or auto-transformers: 1000V a.c. or 1415 V ripple free d.c.		N/A
	– For SMPS including isolating transformers: 500 V a.c. or 708 V ripple-free d.c.		N/A
	– For SMPS including safety isolating transformers: 50 V a.c. or 120 V ripple-free d.c.	Max. 42.07Vd.c. (output terminal)	P
	For independent transformers, this output voltage limitation applies even when output windings, not for interconnection, are connected in series		P
12.202	The difference between output voltage at no load and the output voltage measured in clause 11 does not exceed the values of table 101 (IEC 61558-2-16:09)	(See appended table)	P

IEC 61558-2-16			
Clause	Requirement + Test	Result - Remark	Verdict
12.103	Unless otherwise specified by the manufacturer, SMPS with high frequency output rating shall be tested with 20 cm to 200 cm length of wire connected to the output terminals under the most unfavourable conditions. Two twisted wires or cables rated 60227 IEC 53 may be used. The cross sectional area of the conductors shall be determined according to the rated output of the SMPS, and the current density shall not exceed 5 A/mm ² in normal use. (IEC 61558-2-16:09)		P
13	SHORT-CIRCUIT VOLTAGE		N/A
	Difference from marking for short-circuit voltage $\leq 20\%$		N/A
14	HEATING		P
14.1	General requirements		P
14.1.1	Temperature-rise test		P
	No excessive temperature in normal use		P
	The manufacturer may choose the simulated load methods according to 14.1.2.1 or 14.1.2.2 instead of the direct load method that may be applied.		P
	Room temperature: rated ambient temperature $t_a \pm 5^\circ\text{C}$		—
	Type X, Y, Z attachments: 1 pull (5 N) to the connection windings		P
	Upri (V): 1,1 times rated supply voltage loaded with rated impedance – for independent transformers	90Va.c. and 264Va.c.	—
	Upri (V): 1,1 times rated supply voltage: with 1 sec (A), measured with rated impedance and 1,0 times of the rated supply voltage for others than independent transformers		—
	Type X, Y, Z attachments: 1 pull (5 N) to the connection windings	Type Z attachment for output cord	P
	Max. temperature windings	(See appended table)	P
	– Class A: $\leq 100^\circ\text{C}$		N/A
	– Class E: $\leq 115^\circ\text{C}$		N/A
	– Class B: $\leq 120^\circ\text{C}$		P
	– Class F: $\leq 140^\circ\text{C}$		N/A
	– Class H: $\leq 165^\circ\text{C}$		N/A
	– other classes		N/A
	Temperature of external enclosures of stationary transformers:		N/A
	– bare metal: $\leq 65^\circ\text{C}$		N/A
	– metal covered by lac or varnish		N/A

IEC 61558-2-16			
Clause	Requirement + Test	Result - Remark	Verdict
	– other material: $\leq 80\text{ }^{\circ}\text{C}$		N/A
	Temperature of external enclosure of stationary transformer $\leq 85\text{ }^{\circ}\text{C}$ (not touchable with the IEC test finger)		N/A
	Temperature of external enclosures, handles, etc. of portable transformers:		P
	– continuously held parts of metal: $\leq 48\text{ }^{\circ}\text{C}$		N/A
	– continuously held parts of other material: $\leq 48\text{ }^{\circ}\text{C}$		N/A
	– not continuously held parts of metal: $\leq 60\text{ }^{\circ}\text{C}$		N/A
	– not continuously held parts of other material: $\leq 80\text{ }^{\circ}\text{C}$		P
	Temperature of terminals for external conductors $\leq 70\text{ }^{\circ}\text{C}$		N/A
	Temperature of terminals of switches $\leq 70\text{ }^{\circ}\text{C}$		N/A
	Temperature of internal and external wiring:		P
	– rubber: $\leq 65\text{ }^{\circ}\text{C}$		N/A
	– PVC: $\leq 70\text{ }^{\circ}\text{C}$	Min. $80\text{ }^{\circ}\text{C}$ rating input wire and output wire used (UL approved)	P
	Temperature of parts where safety can be affected:		N/A
	– rubber: $\leq 75\text{ }^{\circ}\text{C}$		N/A
	– phenol-formaldehyde: $\leq 105\text{ }^{\circ}\text{C}$		N/A
	– urea-formaldehyde: $\leq 85\text{ }^{\circ}\text{C}$		N/A
	– impregnated paper and fabric: $\leq 85\text{ }^{\circ}\text{C}$		N/A
	– impregnated wood: $\leq 85\text{ }^{\circ}\text{C}$		N/A
	– PVC, polystyrene and similar thermoplastic material: $\leq 65\text{ }^{\circ}\text{C}$		N/A
	– varnished cambric: $\leq 75\text{ }^{\circ}\text{C}$		N/A
	Temperature rise of supports $\leq 85\text{ }^{\circ}\text{C}$		P
	Temperature of printed boards:		P
	– bonded with phenol-formaldehyde: $\leq 105\text{ }^{\circ}\text{C}$		N/A
	– melamine-formaldehyde: $\leq 105\text{ }^{\circ}\text{C}$		N/A
	– phenol-furfural: $\leq 105\text{ }^{\circ}\text{C}$		N/A
	– polyester: $\leq 105\text{ }^{\circ}\text{C}$		N/A
	– bonded with epoxy: $\leq 140\text{ }^{\circ}\text{C}$	$130\text{ }^{\circ}\text{C}$ rating PCB used (UL approved)	P
	Electric strength between input and output windings (18.3, 1 min); test voltage (V)	Working voltage: 259Va.c. Test voltage: 2870Va.c.	P
14.101	Winding temperature measured by thermocouples at the surface of the winding (IEC 61558-2-16:09)		P

IEC 61558-2-16			
Clause	Requirement + Test	Result - Remark	Verdict
	– if the internal frequencies is > 1kHz		P
	– the values of Table 2 for windings temperatures are reduced by 10°C		P
14.2	Application of 14.1 or 14.3 according to the insulation system		P
14.2.1	Class of insulation system (classified materials according to IEC 60 085 and IEC 60 216)	Class B	P
14.2.2	No classified material, or system but the measured temperature does not exceed the value of Class A		N/A
14.2.3	No classified material or system but the measured temperature exceeds the value for Class A, the live parts of the transformers are submitted to the test of 14.3		N/A
14.3	Accelerated ageing test for undeclared class of insulation system		N/A
14.3.1	General		N/A
	Cycling test (10 cycles):		N/A
	– measuring of the no-load input current (mA)		N/A
14.3.2	– heat run (temperature in table 4)		N/A
14.3.3	– vibration test: 30 min; amplitude 0,35 mm; frequency range: 10 Hz, 55 Hz, 10 Hz		N/A
14.3.4	– moisture treatment (48 h, 17.2)		N/A
14.3.5	Measurements and tests at the beginning and after each test:		N/A
	– deviation of the no-load input current, measured at the beginning of the test is $\leq 30\%$		N/A
	– insulation resistance acc. cl.18.1 and 18.2		N/A
	– electric strength, no breakdown (18.3 and 18.4); 2 min; test voltage 35% of specified value		N/A
	– Transformers (50 or 60 Hz version) are tested after the dielectric strength test as follows: under no load; duration: 5 min; Upri(V):1,2 times rated supply voltage; frequency (Hz): 2 times rated frequency		N/A
15	SHORT-CIRCUIT AND OVERLOAD PROTECTION		P
15.1	General requirements		P
15.1.1	Short circuit and overload test method		P
	Tests direct after 14.1 at the same t_a and without changing position.	(See appended table)	P
	Supply voltage between 0,9 times and 1,1 times of the rated supply voltage	(See appended table)	—
	Transformer with rectifier tests of 15.2 and 15.3 at the input and the output terminals of the rectifier.		P

IEC 61558-2-16			
Clause	Requirement + Test	Result - Remark	Verdict
	Transformers with more than one output winding or tapping, all windings tested with normal load, the winding with the highest temperature is short circuited.		N/A
	Winding protected inherently (15.2)		N/A
	– Max. temperature of winding protected inherently (insulation class): $\leq 150\text{ }^{\circ}\text{C}$ (A); $\leq 165\text{ }^{\circ}\text{C}$ (E); $\leq 175\text{ }^{\circ}\text{C}$ (B); $\leq 190\text{ }^{\circ}\text{C}$ (F); $\leq 210\text{ }^{\circ}\text{C}$ (H)		N/A
	Winding protected by protective device:		P
	– Test according 15.3.2 - 15.3.3 – 15.3.4: max. temperature of winding during the time required or the time T given in table 6 (insulation class): $\leq 200\text{ }^{\circ}\text{C}$ (A); $\leq 215\text{ }^{\circ}\text{C}$ (E); $\leq 225\text{ }^{\circ}\text{C}$ (B); $\leq 240\text{ }^{\circ}\text{C}$ (F); $\leq 260\text{ }^{\circ}\text{C}$ (H)		N/A
	– Test according 15.3.1: max. temperature of winding during the first hour, peak value (insulation class): $\leq 200\text{ }^{\circ}\text{C}$ (A); $\leq 215\text{ }^{\circ}\text{C}$ (E); $\leq 225\text{ }^{\circ}\text{C}$ (B); $\leq 240\text{ }^{\circ}\text{C}$ (F); $\leq 260\text{ }^{\circ}\text{C}$ (H)		P
	– Test according 15.3.1: max. temperature of winding after first hour, peak value (insulation class): $\leq 175\text{ }^{\circ}\text{C}$ (A); $\leq 190\text{ }^{\circ}\text{C}$ (E); $\leq 200\text{ }^{\circ}\text{C}$ (B); $\leq 215\text{ }^{\circ}\text{C}$ (F); $\leq 235\text{ }^{\circ}\text{C}$ (H)		P
	– Test according 15.3.1: max. temperature of winding after first hour, arithmetic mean value (insulation class): $\leq 150\text{ }^{\circ}\text{C}$ (A); $\leq 165\text{ }^{\circ}\text{C}$ (E); $\leq 175\text{ }^{\circ}\text{C}$ (B); $\leq 190\text{ }^{\circ}\text{C}$ (F); $\leq 210\text{ }^{\circ}\text{C}$ (H)		P
	– Test according 15.3.5: max. temperature of winding (insulation class): $\leq 175\text{ }^{\circ}\text{C}$ (A); $\leq 190\text{ }^{\circ}\text{C}$ (E); $\leq 200\text{ }^{\circ}\text{C}$ (B); $\leq 215\text{ }^{\circ}\text{C}$ (F); $\leq 235\text{ }^{\circ}\text{C}$ (H)		P
	Max. temperature of external enclosures (accessible by test finger) $\leq 105\text{ }^{\circ}\text{C}$	(See appended table)	P
	Max. temperature of insulation of wiring (rubber and PVC) $\leq 85\text{ }^{\circ}\text{C}$	(See appended table)	P
	Temperature rise of supports $\leq 105\text{ }^{\circ}\text{C}$	(See appended table)	P
15.1.2	Alternative short circuit and overload test method		N/A
15.2	For inherently short-circuit proof transformers and for transformers with rectifiers test by short circuit of the output winding at rated supply voltage x 1,1: temperature rises \leq values in table 5		N/A
15.3	For non-inherently short-circuit proof transformers and for transformers with rectifiers: temperature rises \leq values in table 5		P

IEC 61558-2-16			
Clause	Requirement + Test	Result - Remark	Verdict
15.3.1	Output terminals short-circuited: protection device operates, test at 0,9 ... 1,1 of the rated supply voltage	1) short-circuit after 14.2 at hot condition, electronic circuit protected immediately; 2) short-circuit at cold condition, electronic circuit protected immediately	P
15.3.2	If protected by a fuse accordance with either IEC 60 269-2 or IEC 60 269-3, or a technical equivalent fuse, the transformer is loaded as in table 6.		N/A
15.3.3	If protected by a fuse accordance with either IEC 60 127(all parts) or ISO 8820(all parts), or a technical equivalent fuse, the transformer is loaded with the current as specified for the longest pre arcing time. <i>If protected by a miniature fuses in accordance to IEC 60127(all parts), 1,5 times of the rated fuse, until steady state condition (in addition)</i>		N/A
15.3.4	If protected by a circuit-breaker according to IEC 60 898(all parts) the transformer is loaded with a current equal to 1,45 times the value of the circuit-breaker rated current		N/A
15.3.5	If other overload protection than a fuse (IEC 60 127) or a circuit-breaker (IEC 60 269) test with 0,95 times of operating current	(See appended table)	P
	If an internal week point is used, the test must be repeated with two new samples. The two additional samples works similar to the first sample. Temperatures in the limit of table 5		N/A
15.4	For non-short-circuit proof transformers: temperature rises \leq values in table 5, tests as indicated in 15.3		N/A
15.5	For fail-safe transformers:		N/A
15.5.1	Three additional new specimens are used		—
	– Upri (V): 1,1 times rated supply voltage		—
	– Isec (A): 1,5 times rated output current		—
	– time until steady-state conditions t1 (h)		—
	– time until failure t2 (h): \leq t1; \leq 5 h		N/A
15.5.2	During the test:		N/A
	– no flames, molten material, etc.		N/A
	– temperature of enclosure \leq 175 °C		N/A
	– temperature of plywood support \leq 125 °C		N/A
	After the test:		N/A

IEC 61558-2-16			
Clause	Requirement + Test	Result - Remark	Verdict
	– electric strength (Cl. 18, 1 min, test voltage: 35% of specified value); no flashover or break-down for primary-to-secondary only for safety isolating, isolating and separating transformer and for primary-to-body for all kinds of transformer		N/A
	– bare hazardous live parts not accessible by test finger through holes of enclosure		N/A
15.101	Electronic circuits of the SMPS fulfil the requirements of Annex H of part 1 . After a fault: no electric shock, no fire hazard and no unintentional operation.	(Details see Annex H)	P
16	MECHANICAL STRENGTH		P
16.1	General		P
	After tests of 16.2, 16.3 and 16.4		P
	– no damage		P
	– hazardous live parts not accessible by test pin according to 9.2.2		P
	– no damage for insulating barriers		N/A
	– handles, levers, etc. have not moved on shafts		N/A
16.2	Stationary transformers	Portable transformers	N/A
	3 blows, impact energy 0,5 ±0,05 J		N/A
16.3	Portable transformers (except of direct plug in transformers)	Direct plug in transformers	N/A
	For portable transformers: 100 falls, 25 mm		N/A
16.4	Portable transformers provided with integral pins for introduction in socket outlets of the fixed wiring		P
16.4.1	General requirements		P
	Portable transformers with integral pins for introduction into fixed socket-outlets shall have adequate mechanical strength.		P
	Plug in power supply units with integral main plug complying with IEC TR 60083, without plugs complying with EN 50075 (IEC plug type C) shall be tested:	Tested for plug type exclude EU plug, refer to "Summary of testing" for details of testing models	P
	a) plug-in transformers: tumbling barrel test: 50 x ≤ 250 g; 25 x > 250 g	<250g, 50 times	P
	b) torque test of the plug pins with 0,4 Nm		P
	c) pull force according to table 7 for each pin	Displacement max. 0.1mm	P
16.4.2	Portable transformers provided with integral pins according to EN 50075 (IEC plug type C) for introduction in socket-outlets of the fixed wiring	Tested for EU plug type, refer to "Summary of testing" for details of testing models	P
	a) The test is carried in a tumbling barrel as described in IEC 60068-2-31.		P

IEC 61558-2-16			
Clause	Requirement + Test	Result - Remark	Verdict
	- 1000 x ≤ 100 g; 100 g < 500 x ≤ 200 g; 200 g < 100 x	<100g, 1000 times	P
	- pull force according to IEC 60884-1:2002, 24.10 for each pin		P
	b) torque test of the plug pins with 0,4 Nm	Displacement max. 0.1mm	P
16.5	Additional requirements for transformers to be used in vehicles and railway applications		N/A
16.5.1	Transformers to be used in vehicles and railway applications		N/A
	An test according IEC 61373 shall be performed with conditions of Table 8 and Table 9 and the frequency values depending on the weight of the specimen are defined in Table 10		N/A
16.5.2	Test requirements for the transportation of transformers		N/A
	Shock and vibration testing requirements for transformers subjected to while being transported per IEC 60721-3-2 with conditions according to Table 11 and Figure 8.		N/A
17	PROTECTION AGAINST HARMFUL INGRESS OF WATER AND MOISTURE		P
17.1	Degree of protection (IP code marked on the transformer)	IP20	P
17.1.1	General requirements		N/A
	Test according to 17.1.2 and for other IP ratings test according to IEC 60 529:		N/A
	– stable operating temperature before starting the test for < IPX8		N/A
	– the water for the test shall be at a temperature of 15±10°C		N/A
	– transformer mounted and wired as in normal use		N/A
	– fixed transformer mounted as in normal use by the tests according to 17.1.2 A to J		N/A
	– portable transformers placed in the most unfavourable position and wired as in normal use		N/A
	– glands tightened with a torque equal to two-thirds of 25.6		N/A
	After the tests:		N/A
	– dielectric strength test according to 18.3		N/A
	Inspection:		N/A

IEC 61558-2-16			
Clause	Requirement + Test	Result - Remark	Verdict
	a) no access with hazardous-live-parts or hazardous moving parts with the relevant test probe according to the test described in 17.1.2, items A 1), B 1) and C 1). The test finger may penetrate but the stop face (ø 50 x 20 mm) shall not pass through the openings for the number 2 of the first characteristic numeral		N/A
	b) no entry into the transformer enclosure by the relevant test probe for solid-object-proof transformers according to test described in 17.1.2, items A 2) and B 2). The protection is satisfactory if the full diameter of the probe does not pass through any openings;		N/A
	c) no deposit of talcum powder in dust-proof transformers		N/A
	d) no deposit of talcum powder inside dust-tight transformers		N/A
	e) no trace of water on live parts except SELV parts below 15 V ac or 25 V dc or insulation if hazard for the user or surroundings no reduction of creepage distances		N/A
	f) no accumulation of water in transformers ≥ IPX1 so as to impair safety		N/A
	g) no trace of water entered in any part of water-tight transformer		N/A
17.1.2	Tests on transformers with enclosure:		P
	A) Solid-object-proof transformers:		P
	- 2 IP2X test finger (IEC 60 529) and test pin (fig. 3)	IP20	P
	- rigid sphere		P
	B) Solid-object-proof transformers:		N/A
	- IP3X, wire 2,5 mm; force 3 N		N/A
	- IP4X, wire 1 mm; force 1 N		N/A
	C) Dust-proof transformers, IP5X;		N/A
	1) At every possible point with a probe according to test probe D of B 1).		N/A
	2) dust chamber according to IEC 60 529, fig. 2:		N/A
	a) transformer has operating temperature		N/A
	b) transformer, still operating, is placed in the dust chamber		N/A
	c) the door of the dust chamber is closed		N/A
	d) fan/blower is switched on		N/A
	e) after 1 min transformer is switched off for cooling time of 3 h		N/A

IEC 61558-2-16			
Clause	Requirement + Test	Result - Remark	Verdict
	D) Dust-tight transformers (IP6X) test according to C)		N/A
	E) Drip-proof transformers (IPX1) test according to fig. 3 of IEC 60 529 for 10 min		N/A
	F) Rain-proof transformers (IPX2) test according to fig. 3 of IEC 60 529 for 10 min in operation, any angle up to 15°		N/A
	G) Spray proofed transformers (IPX3) test according to fig. 4 of IEC 60 529 for 10 min in operation and 10 min switched off, time for complete oscillation (2 x 120°) is 4 sec.		N/A
	H) Splash-proof transformers (IPX4) test according to fig. 4 of IEC 60 529 (see F) for 10 min in operation and 10 min switched off (the tube shall oscillate $\approx 360^\circ$)		N/A
	I) Jet-proof transformer (IPX5) test according to fig. 6 of IEC 60 529 (nozzle 6,3mm)		N/A
	J) Powerful Jet-proof transformer (IPX6) test according to fig. 6 of IEC 60 529 (nozzle 12 mm)		N/A
	K) Watertight transformers (IPX7)		N/A
	L) Pressure watertight transformers (IPX8)		N/A
17.2	After moisture test (48 h for \leq IP20, 168 h for other transformers):	30 °C, 93% R.H., 48 h	P
	– insulation resistance and electric strength (Cl. 18)		P
18	INSULATION RESISTANCE AND ELECTRIC STRENGTH		P
18.2	Insulation resistance between:		P
	– live parts and body for basic insulation $\geq 2 \text{ M}\Omega$		N/A
	– live parts and body for reinforced insulation $\geq 7 \text{ M}\Omega$	(See appended table)	P
	– input circuits and output circuits for basic insulation $\geq 2 \text{ M}\Omega$		N/A
	– input circuits and output circuits for double or reinforced insulation $\geq 5 \text{ M}\Omega$	(See appended table)	P
	– each input circuit and all other input circuits connected together $\geq 2 \text{ M}\Omega$		N/A
	– each output circuit and all other output circuits connected together $\geq 2 \text{ M}\Omega$		N/A
	– hazardous live parts and metal parts with basic insulation (Class II transformers) $\geq 2 \text{ M}\Omega$		N/A
	– body and metal parts with basic insulation (Class II transformers) $\geq 5 \text{ M}\Omega$		N/A
	– metal foil in contact with inner and outer surfaces of enclosures $\geq 7 \text{ M}\Omega$	(See appended table)	P

IEC 61558-2-16			
Clause	Requirement + Test	Result - Remark	Verdict
18.3	Electric strength test (1 min): no flashover or breakdown:		P
	Overvoltage category	II	P
	1) functional insulation; working voltage (V); test voltage (V) :		N/A
	2) basic insulation; working voltage (V); test voltage (V)	(See appended table)	P
	3) supplementary insulation; working voltage (V); test voltage (V)		N/A
	4) double or reinforced insulation:	(See appended table)	P
	5) Functional insulation for windings intended to be connected in series or parallel (test voltage = working voltage + 500 V) (IEC 61558-2-16:09)		N/A
18.3.1	A partial discharge test according to IEC 60664-1, (see test description below) shall be performed, if FIW wires or TIW wires are used and if the recurring peak working voltage U_t across the insulation is greater than 750 V. The relevant recurring peak voltage is the maximum measured voltage between the input and the output circuit, if the secondary side is earthed. The measuring shall be done at 1,0 of the maximum rated input voltage.		N/A
18.4	Does not apply (IEC 61558-2-16:09)		N/A
18.101	Impulse test according Table F5 of IEC 60664-1 with 1,2/50 μ s (IEC 61558-2-16)		P
	– After the test of 18.3, 10 impulses of each polarity between input and output terminals		P
	– During the tests no breakdown of the insulation between turns of a winding, between input and output circuits, or between windings and any conductive core		P
18.102 (A1)	Partial discharge tests according to IEC 60664-1, if the working voltage is > 750 V peak		N/A
	Partial discharge is ≤ 10 pC at time P2 See Fig. 19.101		N/A
18.5	Touch current and protective earthing conductor current		P
18.5.1	General		P
18.5.2	Touch current		P
	Touch current measured after the clause 14 test (hot) for class I and class II transformers (class II transformers with metal foil at the plastic surface). The test circuit according figure 10. Measuring network according Figure J.1 (Annex J). If the frequency is >30kHz, measuring across the 500 Ohm resistor of J.1 (burn effects).		P

IEC 61558-2-16			
Clause	Requirement + Test	Result - Remark	Verdict
	Measurement of the touch current with switch p in both positions and in combination with switches e and n. The measured values are less than the required values of table 15.	Under normal condition of CY2 and CY1 used: Max. 0.080mA (to output terminals); Max. 0.005mA (to accessible enclosure) Under normal condition of CY3 used: Max. 0.160 mA (to output terminals); Max. 0.005mA (to accessible enclosure)	P
	– switches n and e in on position		P
	– switch n: off and switch e: on		P
	– switch n: on and switch e: off		P
18.5.3	Protective earthing conductor current		N/A
	The transformer is connected as in clause 14 Impedance of the ammeter < 0,5 Ohm, connected between earthing terminal of the transformer and protective earthing conductor		N/A
	The measured values are less than the required values of table 15.		N/A
19	CONSTRUCTION		P
19.1	General construction		P
19.1.1	General		P
19.1.2	Auto-transformers		N/A
19.1.2.1	For plug connected auto-transformers with rated input voltage > rated output voltage, the potential to earth shall not exceed the rated output voltage.		N/A
19.1.2.2	Polarised input and output plug and socket-outlet system: an instruction is given with the information, that the transformer shall not be used with non-polarised plug and socket outlet system.		N/A
19.1.2.3	A polarity detecting device only energises the output in the case: output potential to earth \leq rated output voltage, also with reversed input plug.		N/A
	– The contact separation of the device is \geq 3mm		N/A
	– A current to earth does not exceed 0,75 mA.		N/A
	– All tests are repeated under fault conditions of H.3.3 of annex H of part 1. The potential to earth does not exceed the max output voltage for more than 5 s.		N/A
19.1.3	Separating transformers		N/A
19.1.3.1	Input and output circuits electrically separated.		N/A

IEC 61558-2-16			
Clause	Requirement + Test	Result - Remark	Verdict
19.1.3.2	The insulation between input and output winding(s) consist of basic insulation		N/A
	Class I SMPS		N/A
	– Insulation between input windings and body consist of basic insulation		N/A
	– Insulation between output windings and body consist of basic insulation		N/A
	Class II SMPS		N/A
	– Insulation between input windings and body consist of double or reinforced insulation		N/A
	– Insulation between output windings and body consist of double or reinforced insulation		N/A
19.1.3.3	The insulation between input windings and intermediate conductive parts and the output windings and intermediate part consist of basic insulation		N/A
	For class I SMPS the insulation between input and output windings via the intermediate conductive parts consist of basic insulation		N/A
	For class II SMPS the insulation between input winding and the body and between the output windings and the body via the intermediate conductive parts consist of double or reinforced insulation.		N/A
19.1.3.4	Parts of output circuits may be connected to protective earthing		N/A
19.1.3.5	No direct contact between output circuits and the body, unless:		N/A
	– Allowed for associated transformers by the equipment standard		N/A
19.1.4	Isolating transformers and safety isolating transformers		P
19.1.4.1	Input and output circuits electrically separated		P
	No possibility of any connection between these circuits		P
19.1.4.2	The insulation between input and output winding(s) consist of double or reinforced insulation (exception see 19.1.4.4)		P
	Class I transformers not intended for connection to the mains by a plug:		—
	– Insulation between input windings and body connected to earth consist of basic insulation rated to the input voltage		N/A
	– Insulation between output windings and body, connected to earth consist of basic insulation rated for the output voltage		N/A

IEC 61558-2-16			
Clause	Requirement + Test	Result - Remark	Verdict
	Class I transformers intended for connection to the mains by a plug:		N/A
	– Insulation between input windings and body connected to earth consist of basic insulation rated to the working voltage		N/A
	– Insulation between output windings and body, connected to earth consist of supplementary insulation rated for the working voltage		N/A
	Class II transformers		P
	– Insulation between input windings and body consist of double or reinforced insulation rated to the input voltage		P
	– Insulation between output windings and body consist of double or reinforced insulation, rated to the output voltage		N/A
19.1.4.3	For transformers with intermediate conductive parts not connected to the body (between input/output):		P
19.1.4.3.1	For class I and class II transformers the insulation between input and output windings, via intermediate conductive parts, consist of double or reinforced insulation, rated to the working voltage.		P
	– For class II transformers the insulation between input winding and the body and between the output windings and the body via the intermediate conductive parts consist of double or reinforced insulation. (rated to the input voltage and output voltage), for SELV circuits only basic insulation is required.		N/A
	– For transformers, different from independent, the insulation between input and output windings, via intermediate conductive parts, consist of double or reinforced insulation, rated to the working voltage.		P
19.1.4.3.2	Class I transformers with earthed core, and not allowed for class II equipment		N/A
	– Insulation between the input winding and the earthed core: basic insulation rated for the input voltage		N/A
	– Insulation between the output winding and the earthed core: basic insulation rated for the output voltage		N/A
19.1.4.3.3	Insulation between: input to intermediate conductive parts and output and intermediate parts consist of at least basic insulation	The copper between CY1 and CY2 is considered as intermediate part	P
	– If the insulation from input or output to the intermediate metal part is less than basic insulation, the part is considered to be connected to input or output.	The iron core of T1 is considered as primary part	P

IEC 61558-2-16			
Clause	Requirement + Test	Result - Remark	Verdict
19.1.4.4	For class I transformers, with protective screen, not connected to the mains by a plug the following conditions comply:		N/A
	– The insulation between input winding and protective screen consist of basic insulation (rated for the input voltage)		N/A
	– The insulation between output winding and protective screen consist of basic insulation (rated for the output voltage)		N/A
	– The protective screen consist of metal foil or a wire wound screen extending the full width of the windings and has no gaps or holes		N/A
	– Where the protective screen does not cover the entire width of the input winding, additional insulation to ensure double insulation in this area, is used.		N/A
	– If the protective screen is made by a foil, the turns are isolated, overlap at least 3 mm		N/A
	– The cross-section of the screen and the lead out wire is at least corresponding to the rated current of the overload protective device		N/A
	– The lead out wire is soldered or fixed to the protective screen.		N/A
	Protective screening is not allowed for transformers with plug connection to the mains		N/A
19.1.4.5	No connection between output circuit and protective earth, except of associated transformers (allowed by equipment standard) or 19.8 is fulfilled.		N/A
19.1.4.6	No connection between output circuit and body, except of associated transformers (allowed by equipment standard)		P
19.1.4.7	The distance between input and output terminals for the connection of external wiring is ≥ 25 mm		P
19.1.4.8	Portable transformers having an rated output ≤ 630 VA shall be class II.		P
19.1.4.9	No connection between output circuit and body except of associated transformers (allowed by equipment standard)		P
19.1.4.10	Protective screening is not allowed for transformers with plug connection to the mains		N/A
19.2	Fiercely burning material not used		P
	Unimpregnated cotton, silk, paper and fibrous material not used as insulation		P
	Wax-impregnated, etc. not used		P
19.3	Portable transformer: short-circuit proof or fail-safe	Non-inherently short-circuit proof transformer	P

IEC 61558-2-16			
Clause	Requirement + Test	Result - Remark	Verdict
19.4	Class II transformers: contact between accessible metal parts and conduits or metal sheaths of supply wiring impossible		N/A
19.5	Class II transformers: part of supplementary or reinforced insulation, during reassembly after routine servicing not omitted		N/A
19.6	Class I and II transformers: creepage distances and clearances over supplementary or reinforced insulation if wire, screw, nut, etc. become loose or fall out of position not < 50% specified values (Cl. 26)	Input wire and output wire were secured by soldering and glue fixed additionally	P
19.7	Conductive parts connected to accessible metal parts by resistors or capacitors shall be separated from hazardous live parts by double or reinforced insulation		P
19.8	Resistors or capacitors connected between hazardous live parts and the body (accessible metal parts) consist of:	Two Y-capacitors CY1 and CY2 in series used or single Y-capacitor CY3 used	P
	– components according to IEC 60 065, 14.2 or capacitor Y2 according to IEC 60 384-14	The Y capacitors used comply with IEC 60 384-14	P
	– at least two separate components	When two Y-capacitors CY2 and CY1 in series used	P
	– if one component is short-circuited or opened, values specified in Cl. 9 shall not be exceeded	Max. 0.378mA peak (When CY1 and CY2 in series used and CY2 short-circuited)	P
	– if the working voltage is ≤ 250 V, one Y1 capacitor according 60384-14 is allowed		P
	– For a working voltage above 250 V AC and not exceeding 500 V AC and an overvoltage category III, two Y1 capacitors are required.	When single Y-capacitor CY3 use	P
19.9	Insulation material input/output and supplementary insulation of rubber resistant to ageing		N/A
	Creepage distances (if cracks) \leq specified values (Cl. 26)		N/A
19.10	Protection against accidental contact by insulating coating:		N/A
	a) ageing test (IEC 60068-2-14), test Ba: 168 h; 70 °C		N/A
	b) impact test (spring-operated impact hammer according to IEC 60 068-2-75; 0,5 \pm 0,05 J)		N/A
	c) scratch test (hardened steel pin) electric strength test according to Cl. 18		N/A
19.11	Handles, levers, knobs, etc.:		N/A
	– insulating material		N/A
	– supplementary insulation covering		N/A
	– separated from shafts or fixing by supplementary insulation		N/A

IEC 61558-2-16			
Clause	Requirement + Test	Result - Remark	Verdict
19.12	Windings construction		P
19.12.1	Undue displacement in all types of transformers not allowed:	Fixed by bobbin and insulation tape	P
	– of input or output windings or turns thereof		P
	– of internal wiring or wires for external connection		P
	– of parts of windings or of internal wiring in case of rupture or loosening		P
19.12.2	Serrated tape:		N/A
	– distance through insulation according to table 22		N/A
	– one additional layer of serrated tape, and		N/A
	– one additional layer without serration		N/A
	– in case of cheekless bobbins the end turns of each layer shall be prevented from being displaced		N/A
19.12.3	Insulated windings wires providing basic, supplementary or reinforced insulation, meet the following requirements:	Approved TIW used	P
	<ul style="list-style-type: none"> Multi-layer extruded or spirally wrapped insulation, passed the tests of annex K 		N/A
	<ul style="list-style-type: none"> Basic insulation: two wrapped or one extruded wire 		N/A
	<ul style="list-style-type: none"> Supplementary insulation: two layers, wrapped or extruded 		N/A
	<ul style="list-style-type: none"> Reinforced insulation: three layers wrapped or extruded 		P
	Spirally wrapped insulation:		N/A
	<ul style="list-style-type: none"> creepage distances between wrapped layers > cl. 26 _ P1 values 		N/A
	<ul style="list-style-type: none"> path between wrapped layers sealed, the test voltage of K2 is multiplied with 1,35 		N/A
	<ul style="list-style-type: none"> test 26.2.4 – Test A, passed for wrapped layers 		N/A
	<ul style="list-style-type: none"> the finished component pass the electric strength test according to cl. 18.3 		N/A
a)	Insulated winding wire used for basic or supplementary insulation in a wound part:		N/A
	<ul style="list-style-type: none"> comply with annex K 		N/A
	<ul style="list-style-type: none"> two layers for supplementary insulation 		N/A
	<ul style="list-style-type: none"> one layer for basic insulation 		N/A

IEC 61558-2-16			
Clause	Requirement + Test	Result - Remark	Verdict
	<ul style="list-style-type: none"> one layer for mechanical separation between the insulated wires of primary and secondary. This layer fulfils the requirement of basic insulation. 		N/A
b)	Insulated winding wire used for reinforced insulation in a wound part:	Approved TIW used	P
	<ul style="list-style-type: none"> comply with annex K 		P
	<ul style="list-style-type: none"> three layers 		P
	<ul style="list-style-type: none"> relevant dielectric strength test of 18.3 		P
	Where the insulated winding wire is wound:		P
	<ul style="list-style-type: none"> upon metal or ferrite cores 		N/A
	<ul style="list-style-type: none"> upon enamelled wire 		P
	<ul style="list-style-type: none"> under enamelled wire 		P
	<ul style="list-style-type: none"> one layer for mechanical separation between the insulated wires and the core or the enamelled wires is required. This layer fulfils the requirement of basic insulation. 		P
	<ul style="list-style-type: none"> both windings shall not touch each other and also not the core. 		P
	100 % routine test of Annex K3 of part 1 is fulfilled	Approved TIW used	N/A
	no creepage distances and clearances for insulated winding wires		P
c)	Toroidal cores used with TIW wires for double or reinforced insulation between the primary and secondary circuits shall comply with the following:		N/A
	1) a coating which fulfils the requirements of basic insulation between a winding and the core		N/A
	2) The primary winding consists of TIW wire with 3 layers (reinforced insulation) and the secondary winding consists of enamelled wire. These independent windings shall not be able to contact each other either by mechanical separation or a gap which fulfil the dielectric strength tests for basic insulation.		N/A
	3) For polyfilar windings (primary and secondary windings in contact with each other), the primary winding consists of TIW wire with 3 layers and the secondary winding consists of a TIW wire with 1 layer (requirements for primary and secondary windings can be changed). This construction also is allowed for use with EE-cores or similar.		N/A
d)	Toroidal cores used with FIW wires for double or reinforced insulation between the primary and secondary circuits shall comply with the following:		N/A

IEC 61558-2-16			
Clause	Requirement + Test	Result - Remark	Verdict
	1) a coating, which fulfil the requirements of basic insulation.		N/A
	2) The primary winding consists of FIW wire for reinforced insulation and the secondary winding consist of FIW wire – of basic insulation. These independent windings shall not be able to contact each other either by mechanical separation or a gap which fulfil the dielectric strength test for basic insulation.		N/A
	3) For polyfilar windings (primary and secondary windings in contact with each other), the primary winding and the secondary winding consist of FIW wire for reinforced insulation. This construction also is allowed to use for EE-core or similar.		N/A
e)	Toroidal cores used with TIW in combination with FIW wire, for double or reinforced insulation between the primary and secondary circuits shall comply with the following:		N/A
	1) a coating, which fulfils the requirements of basic insulation.		N/A
	2) The primary winding consists of FIW wire for reinforced insulation, and the secondary winding consists of TIW wire for basic insulation (1 layer). These independent windings shall not be able to contact each other either by mechanical separation or a gap which fulfil the dielectric strength tests for basic insulation.		N/A
	3) For polyfilar windings (primary and secondary windings in contact with each other), the primary winding consists of TIW wire for reinforced insulation (3 layer) and the secondary winding consists of FIW wire for reinforced insulation. This construction also is allowed for use with EE-cores or similar.		N/A
f)	Toroidal cores used with TIW in combination with FIW wire, for basic insulation between the primary and secondary circuits shall comply with the following:		N/A
	1) a coating, which fulfils the requirements of basic insulation		N/A
	2) The primary winding consists of FIW wire for basic insulation, and the secondary winding consists of TIW wire for basic insulation (1 layer). These independent windings shall not be able to contact each other either by mechanical separation or a gap which fulfils the dielectric strength tests for basic insulation.		N/A

IEC 61558-2-16			
Clause	Requirement + Test	Result - Remark	Verdict
	3) For polyfilar windings (primary and secondary windings in contact with each other), the primary winding consists of TIW wire for supplementary insulation (2 layers) and the secondary winding consists of FIW wire for basic insulation. This construction also is allowed for use with EE-cores or similar.		N/A
	4) Further polyfilar constructions with FIW and TIW wires in combination with enamelled wires for basic insulation only: 4.1) Primary winding consists of enamelled wire, secondary winding consists of FIW wire for reinforced insulation 4.2) Primary winding consists of enamelled wire, secondary winding consists of TIW wire for reinforced insulation		N/A
19.12.3.1	Max. class F for transformers which use FIW-wire		N/A
19.12.3.2	FIW wires comply with IEC 60851-5:2008, IEC 60317-0-7 and IEC 60317-56.		N/A
	<ul style="list-style-type: none"> other nominal diameter as mentioned in table 24 can be calculated with the Formula (6) in 26.3.5: 		N/A
	FIW wire used for basic or supplementary insulation for transformers according 19.1.3:		–
	<ul style="list-style-type: none"> the test voltage of table 14, based on the working voltage of basic or supplementary insulation, comply with the min. voltage strength of table 24 		N/A
	<ul style="list-style-type: none"> one layer for mechanical separation is located between the insulated wires of primary and secondary. This layer fulfil the requirement of basic insulation 		N/A
	<ul style="list-style-type: none"> between FIW and enamelled wire, no requirements of creepage distances and clearances 		N/A
	<ul style="list-style-type: none"> no touch of FIW and enamelled wires 		N/A
	FIW wire used for double or reinforced insulation for transformers according 19.1.4:		N/A
	<ul style="list-style-type: none"> the test voltage of table 14, based on the working voltage of basic or supplementary insulation, comply with the min. voltage strength of table 24 		N/A
	<ul style="list-style-type: none"> for primary and secondary winding FIW-wire for basic insulation is used 		N/A
	<ul style="list-style-type: none"> one layer for mechanical separation is located between the insulated wires of primary and secondary. This layer fulfil the requirement of basic insulation 		N/A

IEC 61558-2-16			
Clause	Requirement + Test	Result - Remark	Verdict
	<ul style="list-style-type: none"> no touch between the basic insulated PRI and SEC FIW-wires 		N/A
	<ul style="list-style-type: none"> between PRI- and SEC-FIW wires, no requirements of creepage distances and clearances 		N/A
	Alternative construction used for reinforced insulation (reinforced insulated FIW wire and enamelled wire)		N/A
	<ul style="list-style-type: none"> the test voltage of table 14, based on the working voltage reinforced insulation, comply with the min. voltage strength of table 24 		N/A
	<ul style="list-style-type: none"> one layer for mechanical separation is located between the reinforced insulated FIW wire and the enamelled wire. This layer fulfil the requirement of basic insulation 		N/A
	<ul style="list-style-type: none"> no touch between the FIW wire and the enamelled wire 		N/A
	<ul style="list-style-type: none"> between the reinforced FIW wire and any other parts, no requirements of creepage distances and clearances exist 		N/A
	Alternative construction with FIW wires, basic or supplementary insulated for transformers with double or reinforced insulation:		–
	<ul style="list-style-type: none"> the test voltage of table 14, based on the working voltage of basic or supplementary insulation, comply with the min. voltage strength of table 24 		N/A
	<ul style="list-style-type: none"> PRI or SEC basic insulated FIW wire and to the other winding (enamelled wire) requirements of supplementary insulation 		N/A
	<ul style="list-style-type: none"> creepage distances and clearances between the basic insulated FIW wire and the enamelled wire for basic or supplementary insulation are required. 		N/A
	Where the FIW wire is wound		N/A
	<ul style="list-style-type: none"> upon metal or ferrite cores 		N/A
	<ul style="list-style-type: none"> one layer for mechanical separation between the insulated wires and the core or the enamelled wires is required. This layer fulfils the requirement of basic insulation. 		N/A
	<ul style="list-style-type: none"> both windings shall not touch each other and also not the core. 		N/A
19.13	Handles, operating levers and the like shall be fixed		N/A
19.14	Protection against electric shock: covers securely fixed, 2 independent fixing means, one with tool	Enclosure secured by a rim and ultrasonic welding	P

IEC 61558-2-16			
Clause	Requirement + Test	Result - Remark	Verdict
19.15	Transformer with pins for fixed socket-outlets: no strain on socket-outlet		P
	Additional torque ≤ 0,25 Nm	<p>For models CZH015xxxxyyymmWH, CZH015xxxxyyymmWHL: EU plug: 0.040Nm max.; UK plug: 0.029Nm max.;</p> <p>For models CZH015xxxxyyymmWP, CZH015xxxxyyymmWPL: EU plug: 0.040Nm max.; UK plug: 0.030Nm max.;</p> <p>For models CZH015xxxxyyymmWM, CZH015xxxxyyymmWML: EU plug: 0.044Nm max.; UK plug: 0.034Nm max.;</p> <p>For models CZH015xxxxyyymmWF, CZH015xxxxyyymmWFL: EU plug: 0.045Nm max.; UK plug: 0.035Nm max.;</p> <p>For models CZH015xxxxyyymmUM: EU plug: 0.032Nm max.; UK plug: 0.022Nm max.;</p> <p>For models CZH015xxxxyyTRWM, CZH015xxxxyyTRWML: EU plug: 0.048Nm max.; UK plug: 0.038Nm max.;</p> <p>For models CZH015xxxxyyTRWF, CZH015xxxxyyTRWFL: EU plug: 0.048Nm max.; UK plug: 0.039Nm max.;</p> <p>For models CZH015xxxxyyymmWHG, CZH015xxxxyyymmWHLG: EU plug: 0.052Nm max.; UK plug: 0.041Nm max.;</p> <p>For models CZH015xxxxyyymmWPG, CZH015xxxxyyymmWPLG: EU plug: 0.052Nm max.; UK plug: 0.042Nm max.;</p> <p>For models CZH015xxxxyyymmWMG, CZH015xxxxyyymmWMLG:</p>	P

IEC 61558-2-16			
Clause	Requirement + Test	Result - Remark	Verdict
		EU plug: 0.056Nm max.; UK plug: 0.046Nm max.; For models CZH015xxxxyymmWFG, CZH015xxxxyymmWFLG: EU plug: 0.057Nm max.; UK plug: 0.057Nm max.; For models CZH015xxxxyymmWQ, CZH015xxxxyymmWQL: EU plug: 0.027Nm max.; UK plug: 0.028Nm max.; For models CZH015xxxxyymmWQG, CZH015xxxxyymmWQLG: EU plug: 0.034Nm max.; UK plug: 0.038Nm max.; For models CZH015xxxxyyTRWQ, CZH015xxxxyyTRWQL: EU plug: 0.032Nm max.; UK plug: 0.028Nm max.; US/JP plug: 0.030Nm max.; For models CZH015xxxxyyEUWAa: EU plug: 0.032Nm max.; For models CZH015050yyymmUGa: EU plug: 0.018Nm max.; UK plug: 0.018Nm max.	
19.16	Portable transformers for use in irregular or harsh conditions		N/A
	Portable transformers having a weight not exceeding 18 kg shall have a protection index IPX4 or higher.		N/A
19.17	Transformers IPX1 - IPX6 totally enclosed, except for drain hole (diameter \geq 5 mm or 20 mm ² with width \geq 3 mm); drain hole not required for transformer completely filled with insulating materials		N/A
19.18	Transformers \geq IPX1 with a moulded-on plug, if any		N/A
19.19	Class I transformers with a non-detachable flexible cable or cord with earth conductor and a plug with earth contact		N/A
19.20	Live parts of SELV and PELV-circuits: separation not less than PRI/SEC of a safety isolating transformer		P

IEC 61558-2-16			
Clause	Requirement + Test	Result - Remark	Verdict
	– SELV output circuits separated by double or reinforced insulation from all other than SELV or PELV circuits		P
	– SELV output circuits separated by basic insulation from other SELV or PELV circuits		N/A
19.20.1	SELV circuits and parts not connected to protective earth, to live parts, or protective conductors forming part of other circuits		P
	Nominal voltage (V) > 25 V a.c. or 60 V d.c., the required insulation fulfils the high voltage test according to table 8 a		N/A
19.20.2	PELV-circuits double or reinforced insulation is necessary		N/A
19.21	FELV-circuits: protection against contact fulfils the min. test voltage required for the primary circuit		N/A
19.22	Class II transformers shall not be provided with means for protective earth		P
	For fixed transformers an earth conductor with double or reinforced insulation to accessible metal parts is allowed		N/A
19.23	Class III transformers shall not be provided with means for protective earth		N/A
20	COMPONENTS		P
20.1	Components such as switches, plugs, fuses, lamp holders, flexible cables and cords, comply with relevant IEC standard	(See appended table)	P
	Components inside the transformer pass all tests of this standard together with the transformer tests		P
	Testing of components separately to the transformer according the relevant standard:		P
	– Ratings of the component in line with the transformer ratings, including inrush current. Component test according the component standard, based on the component marking (rating).		P
	– Components without markings tested under transformer conditions including inrush current.		P
	– If no IEC standard exists, the component is tested under transformer conditions.		P
20.2	Appliance couplers for main supply shall comply with:		N/A
	– IEC 60 320 for IPX0		N/A
	– 60320-2-3 or IEC 60 309 for other		N/A
20.3	Automatic controls shall comply with IEC 60 730-1		N/A
20.4	Thermal-links comply with IEC 60691		N/A

IEC 61558-2-16			
Clause	Requirement + Test	Result - Remark	Verdict
20.5	Switches shall comply with annex F		N/A
	Disconnection from the supply:		N/A
	– by a switch, disconnecting all poles of the supply (full disconnection under the relevant overvoltage category		N/A
	– or a flexible supply cable and cord with plug		N/A
	– or an instruction sheet: disconnection by all-poles switches incorporated in fixed wiring		N/A
20.6	Socket-outlets of the output circuit shall be such that there is no unsafe compatibility to plugs complying with input circuit.	No standard output plug or socket-outlets for output connections	P
	Plugs and socket-outlets for SELV systems with both a rated current = 3A and a rated voltage =24 V shall comply with following:		P
	SELV plug and socket-outlets shall comply with IEC 60 884-2-4 and IEC 60 906-3		N/A
	– It is not possible for plugs to enter socket-outlets of other standardised voltage system		P
	– Socket outlets do not accommodate plugs of other standardised voltage systems		P
	– Socket outlets do not have a protective earth contact		P
	PELV plug and socket-outlets shall comply with following:		N/A
	– It is not possible for plugs to enter socket-outlets of other standardised voltage system		N/A
	– Socket outlets do not accommodate plugs of other standardised voltage systems		N/A
	– Socket outlets do not have a protective earth contact		N/A
	FELV plug and socket-outlets shall comply with following:		N/A
	– It is not possible for plugs to enter socket-outlets of other standardised voltage system		N/A
	– Socket outlets do not accommodate plugs of other standardised voltage systems		N/A
20.7	Thermal cut-outs, overload releases etc. have adequate breaking capacity		P
	– Thermal cut outs fulfil the relevant requirements of 20.8 and 20.9		N/A
	– Thermal links fulfil the relevant requirements of 20.9		N/A
	– The breaking capacity is in accordance with the relevant fuse standard		P

IEC 61558-2-16			
Clause	Requirement + Test	Result - Remark	Verdict
20.7.1	For Fuses According IEC 60127 and IEC 60269, the fuse current does not exceed 1,1 times of the rated value		P
20.8	Thermal cut outs shall meet the requirements of 20.8.1.1 and 20.8.2, or 20.8.1.2 and 20.8.2.		N/A
20.8.1	Requirements according to IEC 60730-1		N/A
20.8.1.1	Thermal cut-out tested as component shall comply with IEC 60 730-1		N/A
	a) Thermal cut outs type 1 or type 2 (see 6.4 of IEC 60730-1:2013)		N/A
	b) Thermal cut outs fulfil the requirements of micro-interruption (type 1.C or 2.C) or micro-disconnection, (type 1.B or 2.B) (see IEC 60730-1:2013)		N/A
	c) Thermal cut outs with manual reset have a trip free mechanism (type 1.E and 2.E) (see IEC 60730-1:2013)		N/A
	d) The number of cycles of automatic action shall be:		N/A
	– 3000 cycles for self-resetting thermal cut-outs		N/A
	– 300 cycles for non-self-resetting thermal cut-outs resetting by hand		N/A
	– 300 cycles for non-self-resetting thermal cut-outs resetting disconnecting		N/A
	– 30 cycles for non-self-resetting thermal cut-outs which are only resettable by a tool		N/A
	e) Thermal cut outs fulfil the electrical stress according 6.14.2 of IEC 60730-1:2013		N/A
	f) Characteristic of thermal cut-outs:		N/A
	– ratings according IEC 60730-1:2013, cl. 5		N/A
	– classification according to:		N/A
	1) nature of supply to IEC 60730-1:2013, cl. 6.1		N/A
	2) type of load controlled to IEC 60730-1, cl. 6.2		N/A
	3) degree of protection IPX0 to IEC 60730-1:2013, cl. 6.5.1		N/A
	4) degree of protection IP0X to IEC 60730-1:2013, cl. 6.5.2		N/A
	5) pollution degree to IEC 60730-1:2013, cl. 6.5.3		N/A
	6) comparative tracking index to IEC 60730-1:2013, cl. 6.13		N/A
	7) max. ambient temperature to IEC 60730-1:2013, cl. 6.7		N/A

IEC 61558-2-16			
Clause	Requirement + Test	Result - Remark	Verdict
20.8.1.2	Thermal cut-out tested as a part of the transformer, test with 3 samples:		N/A
	– at least micro-interruption or micro-disconnection (IEC 60730-1:2013)		N/A
	– 300 h aged at t_a (transformer) + 10°C		N/A
	– subjected to a number of cycles for automatic operating according 20.8.1.1		N/A
	During the test no sustaining arcing shall occur, during and after the test no damage at the thermal cut out and the transformer in the sense of this standard		N/A
20.8.2	Thermal cut-outs shall have adequate breaking capacity		N/A
20.8.2.1	The output of the transformer with a non-self-resetting thermal cut out is short circuited at a supply voltage 1, 1 of rated supply voltage. After opening of the cut off, the supply voltage is switched of, until the transformer is cooling down.		N/A
	– 3 cycles at 25° C for transformers without t_{amin}		N/A
	– 3 cycles at t_{amin} for transformers with t_{amin}		N/A
	– after the 3 cycles short circuit of the output at 1,1 of rated supply voltage for 48 h.		N/A
	During the tests no sustaining arcing shall occur After the test: withstand the test of clause 18, show no damage in sense of this standard, and be operational.		N/A
20.8.2.2	The output of the transformer with a self-resetting thermal cut out is short circuited at a supply voltage 1, 1 of rated supply voltage.		N/A
	– 48 h at 25° C for transformers without t_{amin}		N/A
	– 24 h at t_a and 24 h at t_{amin} for transformers with t_{amin}		N/A
	During the tests no sustaining arcing shall occur After the test: withstand the test of clause 18, show no damage in sense of this standard, and be operational.		N/A
20.8.3	Test of a PTC resistor:		N/A
	5 cycles: transformer short-circuited for 48 h by 1,1 times of the input voltage and max. t_a		N/A
	5 cycles: transformer short-circuited for 48 h by 0,9 times of the input voltage and min. t_a (if declared)		N/A
	After the test: withstand the test of clause 18, show no damage in sense of this standard, and be operational.		N/A

IEC 61558-2-16			
Clause	Requirement + Test	Result - Remark	Verdict
20.9	Thermal links shall be tested in one of the following two ways.		N/A
20.9.1	Thermal-links shall comply with IEC 60 691 as a separate component.		N/A
	– electrical conditions to IEC 60691, cl. 6.1		N/A
	– thermal conditions to IEC 60691, cl. 6.2		N/A
	– ratings to IEC 60691, cl. 8 b		N/A
	– suitability of sealing components, impregnating fluids or cleaning solvents IEC 60691, cl. 8 c		N/A
20.9.2	Thermal-links tested as a part of the transformer:		N/A
	– ageing test 300 h by 35 °C or ta + 10 °C		N/A
	– After transformer fault condition the thermal link operate without sustaining arcing		N/A
	– after opening the thermal-link shall have an insulation resistance of at least 0,2 MΩ		N/A
	– 3 cycles for replaceable thermal-links		N/A
	– 3 new specimens for not replaceable thermal-links		N/A
20.10	Self-resetting devices not used if mechanical, electrical, etc. hazards		N/A
20.11	Thermal cut-outs which can be reset by soldering operation are not allowed		N/A
20.12	Overload protection devices do not operate during test (20 times switched on and off, at no load); Upri (V): 1,1 times rated supply voltage.	264V, 20 times, intervals 10s	P
21	INTERNAL WIRING		P
21.1	Internal wiring and electrical connections protected or enclosed	The input wire and output wire were double fixed by soldering and glue	P
	Wire-ways smooth and free from sharp edges		P
21.2	Openings in sheet metal: edges rounded (radius ≥ 1,5 mm) or bushings of insulating material		N/A
21.3	Bare conductors: distances adequately maintained		N/A
21.4	When external wires are connected to terminal, internal wiring shall not work loose	The input wire and output wire were double fixed by soldering and glue	P
21.5	Insulation of heat-resistant and non-hygroscopic material for insulated conductors subject to temperature rise > limiting values given in 14.1	Not exceeding the limitations in clause 14.1	N/A
22	SUPPLY CONNECTION AND EXTERNAL FLEXIBLE CABLES AND CORDS		P
22.1	All cables, flexible cords etc. shall have appropriate current and voltage ratings	(See appended table)	P

IEC 61558-2-16			
Clause	Requirement + Test	Result - Remark	Verdict
22.2	Input and output wiring inlet and outlet openings for external wiring: separate entries without damage to protective covering of cable or cord		P
	Input and output wiring inlet and outlet openings for flexible cables or cords: insulating material or bushing of insulating material		P
	Bushings for external wiring: reliably fixed, not of rubber unless part of cord guard		P
22.3	Fixed transformer:		N/A
	– possible to connect after fixing		N/A
	– inside space for wires allow easy introduction and connection of conductors		N/A
	– fitting of cover without damage to conductors		N/A
	– contact between insulation of external supply wires and live parts of different polarity not allowed		N/A
22.4	Length of power supply cord for portable transformers:		N/A
	– not exceed 2 m for cross-sectional area of 0,5 mm ²		N/A
	– exceed 2 m for cross-sectional areas greater than 0,5 mm ² .		N/A
22.5	Power supply cords for transformers IP20 or higher and transformers” for indoor use only” ≥ IP20:		N/A
	– for transformers with a mass ≤ 3 kg: IEC 60227-5:2011 – type 60227 IEC 52 or ordinary tough rubber sheathed flexible cable or cords according to IEC 60245-4:2011 – type 60245 IEC 53;		N/A
	– for transformers with a mass > 3 kg: IEC 60227-5:2011 – type 60227 IEC 53 or ordinary tough rubber sheathed flexible cable or cords according to IEC 60245-4:2011 – type 60245 IEC 53.		N/A
	Power supply cords for transformers for outdoor use: ≥ IPX0: IEC 60245-4:2011 – type 60245 IEC 57		N/A
22.6	Power supply cords for single-phase portable transformers with input current ≤ 16A:		N/A
	– cord set fitted with an appliance coupler in accordance with IEC 60320(all parts)		N/A
22.7	Nominal cross-sectional area (mm ²); input current (A) at rated output not less than shown in table 16	(See appended table)	P
22.8	Class I transformer with power supply flexible cable: green/yellow core connected to earth terminal		N/A

IEC 61558-2-16			
Clause	Requirement + Test	Result - Remark	Verdict
	Plug for single-phase transformer with input current at rated output 16 A according to IEC 60 083, IEC 60 906-1 or IEC 60 309(all parts)		N/A
22.9	Type X, Y or Z attachments: see relevant part of IEC 61558-2.	Type Z attachment for output cord	P
22.9.1	For type Z attachment: moulding enclosure and external flexible cable or cord do not affect insulation of cable		P
22.9.2	Inlet openings or inlet bushing: without risk of damage to protective covering of external flexible cable or cord		N/A
	Insulation between conductor and enclosure:		N/A
	– for Class I transformer: insulation of conductor plus separate basic insulation		N/A
	– for Class II transformer: insulation of conductor plus double or reinforced insulation		N/A
	The sheath of an external flexible cable or cord equivalent to at least that of a cord complying with IEC 60227 (all parts) or 60245 (all parts) is regarded as basic insulation.		N/A
	A lining or a bushing of insulating material in a metallic enclosure is only regarded as supplementary insulation		N/A
	An enclosure of insulating material is regarded as reinforced insulation		N/A
22.9.3	Inlet bushings:		N/A
	– no damage to external flexible cable or cord		N/A
	– reliably fixed		N/A
	– not removable without tool		N/A
	– not integral with external flexible cable or cord (for type X attachment)		N/A
	– not of natural rubber except for Class I transformer with type X, Y and Z attachments		N/A
22.9.4	For transformers which are moved while operating:		N/A
	– cord guards, if any, of insulating material and fixed		N/A
	Compliance is tested by the oscillating test according to fig. 12:		N/A
	– loaded force during the test according to fig. 12		N/A
	– 10 N for a cross-sectional area > 0,75mm ²		N/A
	– 5 N for other cords		N/A
	After the test according to fig. 12:		N/A
	– no short-circuit between the conductors		N/A

IEC 61558-2-16			
Clause	Requirement + Test	Result - Remark	Verdict
	– no breakage of more than 10% of strands of any conductor		N/A
	– no separation of the conductor from the terminal		N/A
	– no loosening of any cord guards		N/A
	– no damage of the cord or cord guard		N/A
	– no broken strands piercing the insulation and not becoming accessible		N/A
22.9.5	Cord anchorages for type X attachment:		N/A
	– glands in portable transformers not used unless possibility for clamping all types and sizes of cable		N/A
	– moulded-on designs, tying the cable into a knot and tying the end with string not allowed		N/A
	– labyrinths, if clearly how, permitted		N/A
	– replacement of cable easily possible		N/A
	– protection against strain and twisting clearly how		N/A
	– suitable for different types of cable unless only one type of cable for transformer		N/A
	– the entire flexible cable or cord with covering can be mounted into the cord anchorage		N/A
	– if tightened or loosened no damage		N/A
	– no contact between cable or cord and accessible or electrically connected clamping screws		N/A
	– cord clamped by metal screw not allowed		N/A
	– one part securely fixed to transformer		N/A
	– for Class I transformer: insulating material or insulated from metal parts		N/A
	– for Class II transformers: insulating material or supplementary insulation from metal parts		N/A
	Cord anchorages for type X, Y, Z attachments: cores of power external flexible cable or cord insulated from accessible metal parts by:		N/A
	– basic insulation (Class I transformers), separate insulating barrier/cord anchorage		N/A
	– supplementary insulation (Class II transformers), special lining/cable or cord sheath of cable sheath of cable		N/A
	Cord anchorages for type X and Y attachments:		N/A
	– replacement of external flexible cable or cord does not impair compliance with standard		N/A
	– the entire flexible cable or cord with covering can be mounted into the cord anchorage		N/A

IEC 61558-2-16			
Clause	Requirement + Test	Result - Remark	Verdict
	– if tightened or loosened no damage		N/A
	– no contact between cable or cord and accessible or electrically connected clamping screws		N/A
	– cord clamped by metal screws not allowed		N/A
	– knots in cord not used		N/A
	– labyrinths, if clearly how, permitted		N/A
	Tests for type X with special cords, type Y, type Z	Type Z attachment for output cord	P
	Test for type X attachments one test with a cord with smallest and one test with a cord with the largest cross-sectional area:		N/A
	– for the test with clamping screws or tightened with torque 2/3 of that specified in table 18		N/A
	– not possible to push cable into transformer		P
	– 25 pulls of 1 s		P
	– 1 min torque according to table 17		P
	mass (kg); pull (N); torque (Nm) :	Approx. 0.073-0.105kg, 30N, 0.1Nm for output wire. (All enclosure types are considered)	—
	– during test: cable not damaged		P
	– after test: longitudinal displacement ≤ 2 mm for cable or cord and ≤ 1 mm for conductors in terminals	Max. 0.6mm longitudinal displacement for output cord; Max. 0.2mm longitudinal displacement for conductors in output cord terminals. (All enclosure types are considered)	P
	– creepage distances and clearances \geq values specified in Cl. 26		P
22.9.6	Space for external cords or cable for fixed wiring and for type X and Y attachments:		N/A
	– before fitting cover, possibility to check correct connection and position of conductors		N/A
	– cover fitted without damage to supply cords		N/A
	– for portable transformers: contact with accessible metal parts if conductor becomes loose not allowed unless for type X and Y attachments terminations of cords do not slip free of conductor		N/A
	Space for external cords or cable for type X attachment and for connection to fixed wiring, in addition:		N/A
	– conductor easily introduced and connected		N/A

IEC 61558-2-16			
Clause	Requirement + Test	Result - Remark	Verdict
	– possibility of access to terminal for external conductor after removal of covers without special purpose tool		N/A
23	TERMINALS FOR EXTERNAL CONDUCTORS		N/A
23.1	Transformer for connection to fixed wiring and transformer without power supply cords with type Y and Z attachments: only connections by screws, nuts, terminals	No such terminals used	N/A
	Terminals are integral part of the transformer:		N/A
	– comply with IEC 60 999-1 under transformer conditions		N/A
	Other terminals:		N/A
	– separately checked according to IEC 60 998-2-1, IEC 60 998-2-2 or IEC 60 947-7-1		N/A
	– used in accordance with their marking		N/A
	– checked according to IEC 60 999-1 under transformer conditions		N/A
	Transformer with type X attachments: soldered connection permitted if reliance not placed upon soldering, crimping or welding alone unless by barriers, creepage distances and clearances between hazardous live parts and other conductive part cannot be reduced to less than 50% of specified value (Cl.26) should conductor break away		N/A
	Transformer with type Y and Z attachments for external conductors: soldered, welded, crimped, etc. connections allowed		N/A
	For Class II transformer: reliance not placed upon soldering, crimping or welding alone unless by barriers, creepage distances and clearances between hazardous live parts and other conductive parts cannot be reduced to less than 50% of specified value (Cl.26) should conductor break away		N/A
23.2	Terminals for type X with special cords Y and Z attachments shall be suitable for their purpose:		N/A
	– test by inspection according to 23.1 and 23.2		N/A
	– pull of 5 N to the connection before test according to 14.1		N/A
23.3	Other terminals than Y and Z attachments shall be so fixed that when the clamping means is tightened or loosened:		N/A
	– terminal does not work loose		N/A
	– internal wiring is not subjected to stress		N/A
	– creepage distances and clearance are not reduced below the values specified in Cl. 26		N/A

IEC 61558-2-16			
Clause	Requirement + Test	Result - Remark	Verdict
23.4	Other terminals than Y and Z attachments shall be so designed that:		N/A
	– they clamp the conductor between metallic surfaces with sufficient contact pressure		N/A
	– without damage to the conductor		N/A
	– test by inspection according to 23.3 and 23.4		N/A
	– 10 times fastening and loosening a conductor with the largest cross-sectional area with 2/3 of the torque specified in Cl. 25		N/A
23.5	Terminals for fixed wiring and for type X: located near their associated terminals of different polarities and the earth terminal if any		N/A
23.6	Terminal blocks not accessible without the aid of a tool		N/A
23.7	Transformer with type X attachments: stranded conductor test (8 mm removed):		N/A
	– Class I transformers: no connection between live parts and accessible metal parts		N/A
	– free wire of earth terminal: no touching of live parts		N/A
	– Class II transformers: no connection between live parts and accessible metal parts, no connection between live parts and metal parts separated from accessible metal parts by supplementary insulation		N/A
23.8	Terminals for a current > 25 A:		N/A
	– pressure plate, or		N/A
	– two clamping screws		N/A
23.9	When terminal, other than protective earth conductor, screws loosened as far as possible, no contact:		N/A
	– between terminal screws and accessible metal parts		N/A
	– between terminal screws and accessible metal parts separated only by basic or supplementary insulation for Class II transformers		N/A
24	PROVISION FOR PROTECTIVE EARTHING		P
24.1	Class I transformers: accessible conductive parts connected to earth terminal	Class II transformer	N/A
	Class II transformers: no provision for protective earth		P
24.2	Protective earth terminal for connection to fixed wiring and for type X attachment transformers: comply with Cl. 23, adequately locked, not possible to loosen without a tool		N/A

IEC 61558-2-16			
Clause	Requirement + Test	Result - Remark	Verdict
24.3	No risk of corrosion from contact between metal of earth terminal and other terminal		N/A
	In case of earth terminal body of Al, no risk of corrosion from contact between Cu and Al		N/A
	Body of earth terminal or screws/nuts of brass or other metal resistant to corrosion		N/A
24.4	Resistance of connection between earth terminal and metal parts $\leq 0,1\Omega$ with a min. 25 A or 1,5 times rated input current at 1 min		N/A
24.5	Class I transformers with external flexible cables or cords:		N/A
	– current-carrying conductors becoming touch before the earth conductor		N/A
25	SCREWS AND CONNECTIONS		N/A
25.1	Screwed connections withstand mechanical stresses	No such screws used	N/A
	Screws transmitting contact pressure or likely to be tightened by the user or having a diameter < 2,8 mm, shall screw into metal		N/A
	Screws not of metal which is soft or liable to creep (Zn, Al)		N/A
	Screws of insulating material: not used for electrical connection		N/A
	Screws not of insulating material if their replacement by metal screws can impair supplementary or reinforced insulation		N/A
	Screws to be removed (replacement etc. of power supply cord) not of insulating material if their replacement by metal screws can impair basic insulation		N/A
	No damage after torque test: diameter (mm); torque (Nm); ten times		N/A
	No damage after torque test: diameter (mm); torque (Nm); five times		N/A
25.2	Screws in engagement with thread of insulating material:		N/A
	– length of engagement ≥ 3 mm + 1/3 screw diameter or 8 mm whichever is shorter		N/A
	– correct introduction into screw hole		N/A
25.3	Electrical connections: contact pressure not transmitted through insulating material		N/A
25.4	In case of use of thread-forming (sheet metal) screws for connection of current-carrying parts: clamping and locking means provided		N/A

IEC 61558-2-16			
Clause	Requirement + Test	Result - Remark	Verdict
	Thread-cutting (self-tapping) screws used for the connection of current-carrying parts allowed if they generate a full form machine screw thread and if not operated by the user		N/A
	Thread-cutting screws and thread-forming screws used for earth continuity allowed if at least 2 screws for each connection are used and it is not necessary to disturb the connection in normal use		N/A
25.5	Screws for current-carrying mechanical connections locked against loosening		N/A
	Rivets for current-carrying connections subject to torsion locked against loosening		N/A
25.6	Test of screwed glands with a torque according table 19. After the test no damage at the transformer and the gland.		N/A
26	CREEPAGE DISTANCES AND CLEARANCES		P
26.2	Creepage distances (cr) and clearances (cr)		P
26.2.1	General		P
26.2.2	Windings covered with adhesive tape		N/A
	– the values of pollution degree 1 are fulfilled		N/A
	– all isolating material are classified acc. to IEC 60085 and IEC 60216(all parts)		N/A
	– test A of 26.2.4 is fulfilled		N/A
26.2.3	Uncemented insulating parts pollution degree P2 or P3		N/A
	– all isolating material are classified acc. to IEC 60085 and IEC 60216(all parts)		N/A
	– values of pollution degree 1 are not applicable		N/A
26.2.4	Cemented insulating parts		N/A
	– all isolating materials are classified acc. to IEC 60085 and IEC 60216(all parts)		N/A
	– values of distance through insulation (dti) are fulfilled		N/A
	– creepage distances and clearances are not required		N/A
	– test A of this sub clause is fulfilled		N/A
	Test A		N/A
	– thermal class		N/A
	– working voltage		N/A
	– Test with three specially specimens, with uninsulated wires, without impregnation or potting		N/A
	Two of the three specimens are subjected to:		N/A

IEC 61558-2-16			
Clause	Requirement + Test	Result - Remark	Verdict
	– the relevant humidity treatment according to 17.2 (48 h)		N/A
	– the relevant dielectric strength test of 18.3 multiplied with factor 1,35		N/A
	– One of the three specimens is subjected to the relevant dielectric strength test of 18.3 multiplied by the factor 1,35 immediately at the end of the last cycle with high temperature		N/A
	Impulse dielectric test according to 6.1.2.2.1 of IEC 60664-1:2007 – see Annex R of IEC 61558-1		N/A
26.2.5	Enclosed parts, by impregnation or potting		N/A
26.2.5.1	– The requirements of reduced values as stated for pollution degree 1 (P1) are fulfilled		N/A
	– all isolating materials are classified acc. to IEC 60085 and IEC 60216(all parts)		N/A
	Test B		N/A
	– thermal class		N/A
	– test voltage of 500 V or the working voltage		N/A
	– Test with three specially specimens, potted or impregnated. The dielectric strength test is applied directly to the joint.		N/A
	Two of the three specimens are subjected to:		N/A
	– the relevant humidity treatment according to 17.2 (48 h)		N/A
	– the relevant dielectric strength test of 18.3 multiplied with factor 1,25		N/A
	– One of the three specimens is subjected to the relevant dielectric strength test of 18.3 multiplied by the factor 1,25 immediately at the end of the last cycle with high temperature		N/A
	The three spacemen pass the Impulse dielectric test according to 6.1.2.2.1 of IEC 60664-1:2007– see Annex R of IEC 61558-1		N/A
26.2.5.2	– The requirements of distance through insulation (dti) are fulfilled. (P1 values are not required)		N/A
	– all isolating materials are classified acc. to IEC 60085 and IEC 60216(all parts)		N/A
	Test C		N/A
	– thermal class		N/A
	– test voltage of 500 V or the working voltage		N/A
	– Test with three specimens, potted or impregnated. (finished components)		N/A

IEC 61558-2-16			
Clause	Requirement + Test	Result - Remark	Verdict
	– Neither cracks, nor voids in the insulating compounds		N/A
	Two of the three specimens are subjected to:		N/A
	– the relevant humidity treatment according to 17.2 (48 h)		N/A
	– the relevant dielectric strength test of 18.3 multiplied with factor 1,35		N/A
	– One of the three specimens is subjected to the relevant dielectric strength test of 18.3 multiplied by the factor 1,35 immediately at the end of the last cycle with high temperature		N/A
	The three spacemen pass the Impulse dielectric test according to 6.1.2.2.1 of IEC 60664-1:2007 – see Annex R of IEC 61558-1		N/A
26.3	Distance through insulation		P
26.3.1	For supplementary, double or reinforced insulation, the required values of Tables 22 are fulfilled		P
	The insulation fulfil the material classification according IEC 60085 and 60216(all parts) or the test of 14.3	Approved insulation material used	P
26.3.2	Reduced values of the thickness of insulation for supplementary or reinforced insulation are allowed if the following conditions are fulfilled:		N/A
	– the isolating materials are classified acc. to IEC 60085 and IEC 60216(all parts)		N/A
	– the test of 14.3 is fulfilled		N/A
	– If both requirements are fulfilled, the required values for solid insulation can be multiplied by 0,4		N/A
	– Minimum thickness of reinforced insulation $\geq 0,2$ mm		N/A
	– Minimum thickness of supplementary insulation $\geq 0,1$ mm		N/A
26.3.3	Insulation in thin sheet form		N/A
	– If the layers are non-separable (glued together):		N/A
	– The requirement of 3 layers is fulfilled		N/A
	– The mandrel test according 26.3.4 is fulfilled with 150 ± 10 N		N/A
	– The required values for d.t.i. of thin layers in Tables 22 is fulfilled.		N/A
	– If the layers are separated:		N/A
	– The requirement of 2 layers is fulfilled		N/A

IEC 61558-2-16			
Clause	Requirement + Test	Result - Remark	Verdict
	– If serrated tape is used, 1 additional layer (serrated) and one additional layer without serration is required		N/A
	– The mandrel test according 26.3.4 is fulfilled on each layer with 50±5 N		N/A
	– The required values for d.t.i. of thin layers in Tale 22 is fulfilled.		N/A
	– If the layers are separated (alternative:		N/A
	– The requirement of 3 layers is fulfilled		N/A
	– If serrated tape is used, 1 additional layer (serrated) and one additional layer without serration is required		N/A
	– The mandrel test according 26.3.4 is fulfilled on 2/3 of the layers with 100±5 N		N/A
	– The required values for d.t.i. of thin layers in Tale 22 is fulfilled.		N/A
	Test according to 14.3 and if the isolating materials are classified acc. to IEC 60085 and IEC 60216(all parts) no distances through insulation are required for insulation in thin sheet form		N/A
	The values for thin layers are used for insulation in thin sheet form as follows:		N/A
	– rated output > 100 VA values for thin layers apply		N/A
	– rated output ≥ 25 VA ≤ 100 VA 2/3 of the values for thin layers apply		N/A
	– rated output ≤ 25 VA 1/3 of the values for thin layers apply		N/A
26.3.4	Mandrel test of insulation in thin sheet form (specimen of 70±0,5 mm width are necessary):		N/A
	– If the layers are non-separable – at least 3 layers glued together fulfil the test:		N/A
	– pull force of 150±10 N		N/A
	– high voltage test of 5,0 kV or the test voltage of 18.3 multiplied by 1,25 whatever is the greater. No flashover, no breakdown.		N/A
	– If the layers are separable and 2/3 of at least 3 layers fulfil the test.		N/A
	– pull force of 100±5 N		N/A
	– high voltage test of 5,0 kV or the test voltage of 18.3 multiplied by 1,25 whatever is the greater. No flashover, no breakdowns.		N/A
	– If the layers are separable 1 of at least 2 layers fulfil the test:		N/A
	– pull force of 50±5 N		N/A

IEC 61558-2-16			
Clause	Requirement + Test	Result - Remark	Verdict
	– high voltage test of 5,0 kV or the test voltage of 18.3 multiplied by 1,25 whatever is the greater. No flashover, no breakdown.		N/A
26.3.5	For transformers with FIW wires		N/A
	– thermal cycles		N/A
	– test voltage of 500 V or the working voltage		N/A
	– Test with three specimens		N/A
	Two of the three specimens are subjected to:		N/A
	– the relevant humidity treatment according to 17.2 (48 h)		N/A
	– the relevant dielectric strength test of 18.3		N/A
	– One of the three specimens is subjected to the relevant dielectric strength test of 18.3 immediately at the end of the last cycle with high temperature		N/A
	The partial discharge test shall be done at the end of the cycling test at normal room temperature as performed in 18.3.1.		N/A
	The values of allowed voltage strength for other FIW dimensions than defined in Table 24 are calculated		N/A
26.101	Creepage distances, clearances and distances through insulation, specified values according to (IEC 61558-2-16:09):		P
	– table 13, material group IIIa (part 1)		P
	– table C, material group II (part 1)		N/A
	– table D, material group I (part 1)		N/A
	– working voltage		P
	– rated supply frequency 50/60 Hz		P
	– rated internal frequency		P
	1. Insulation between input and output circuits (basic insulation):		N/A
	a) measured values \geq specified values (mm)		N/A
	2. Insulation between input and output circuits (double or reinforced insulation):		P
	a) measured values \geq specified values (mm)	(See appended table)	P
	b) measured values \geq specified values (mm)		N/A
	c) measured values \geq specified values (mm)	(See appended table)	P

IEC 61558-2-16			
Clause	Requirement + Test	Result - Remark	Verdict
	3. Insulation between adjacent input circuits: measured values \geq specified values (mm:		N/A
	Insulation between adjacent output circuits: measured values \geq specified values (mm)..:		N/A
	4. Insulation between terminals for external connection:		N/A
	a) measured values \geq specified values (mm)		N/A
	b) measured values \geq specified values (mm)		N/A
	c) measured values \geq specified values (mm)		N/A
	5. Basic or supplementary insulation:		P
	a) measured values \geq specified values (mm)	(See appended table)	P
	b) measured values \geq specified values (mm)		N/A
	c) measured values \geq specified values (mm)		N/A
	d) measured values \geq specified values (mm)		N/A
	e) measured values \geq specified values (mm)		N/A
	6. Reinforced or double insulation: measured values \geq specified values (mm)	(See appended table)	P
	7. Distance through insulation:		P
	a) measured values \geq specified values (mm)		N/A
	b) measured values \geq specified values (mm)		N/A
	c) measured values \geq specified values (mm)	(See appended table)	P
26.102	Values of IEC 61558-2-16 applicable for frequency up to 3 MHz (IEC 61558-2-16:09)		P
	For frequency above 3 MHz clause 7 of IEC 60664-4 is applicable (high frequency testing)		N/A
26.103	Clearance (IEC 61558-2-16:09)		P
	a) Clearance for frequency \geq 30 kHz according figure 101 two determinations are necessary:		P
	– determination based on peak working voltage according Table 104:		P
	Peak working voltage		P
	Basic insulation: required / measured		P

IEC 61558-2-16			
Clause	Requirement + Test	Result - Remark	Verdict
	Double or reinforced insulation: required / measured value		P
	– and alternative if applicable for approximately homogeneous field according to Table 102		P
	Peak working voltage		P
	Basic insulation: required / measured		P
	Double or reinforced insulation: required / measured value		P
	– determination based on measured r.m.s. working voltage according Tables 13, C1 and D1 (see clause 26.101)		P
	The minimum clearance is the greater of the two values.		P
	b) Clearance for frequency ≤ 30 kHz according figure 101 two determinations are necessary:		P
	– determination based on peak working voltage with recurring peak voltages according Table 103:		P
	– determination based on measured r.m.s. working voltage according Tables 13, C1 and D1 (see clause 26.101)		P
	The minimum clearance is the greater of the two values.		P
26.104	The working voltages of Table 102, 103 and 104 are peak voltages including μ sec peaks (IEC 61558-2-16:09)		P
	The working voltage according to Table 13 of part 1 are r.m.s. voltages		P
26.105	Creepage distances		P
	Two determinations of creepage distances are necessary (see Figure 102)		P
	– determination based on measured peak working voltage according Tables 105 to 110		P
	Peak working voltage		P
	Pollution degree	2	P
	Basic or supplementary insulation: required / measured		P
	Double or reinforced insulation: required / measured value		P
	– determination based on measured r.m.s. working voltage according Tables 13, C1 and D1 (see clause 26.101)		P

IEC 61558-2-16			
Clause	Requirement + Test	Result - Remark	Verdict
	If the values based on table 105 to 110 are lower than the relevant values in Tables 13, C.1 or D.1, the higher values shall be applicable		P
26.106	Distance through insulation (IEC 61558-2-16:09)		P
	Instead of partial discharge with high frequency voltage the test of the distance and the calculation of the electric field is applicable under the following conditions:		P
	– the max. frequency is < 10 MHz		P
	– the field strength approximately comply with Figure 103		P
	– no voids or gaps are present in between the solid insulation		P
	For thick layers $d1 \geq 0,75$ the peak value of the field strength is ≤ 2 kV/mm		N/A
	For thin layers $d2 \leq 30$ μ m the peak value of the field strength is ≤ 10 kV/mm		N/A
	For $d1 > d > d2$ equation (1) is used for calculation the field strength		P
26.107 (A1)	For transformers with FIW wires the following test is required		N/A
	<ul style="list-style-type: none"> 10 cycles are required 		N/A
	<ul style="list-style-type: none"> 68 h test at max heating temperature + 10°C or test at max. allowed winding temperature based on the insulation class (required in table 1) + 10°C 		N/A
	<ul style="list-style-type: none"> 1 h at 25° C 		N/A
	<ul style="list-style-type: none"> 2 h at 0° C 		N/A
	<ul style="list-style-type: none"> 1 h at 25° C – (next cycle start again with 68 h max winding temp + 10) 		N/A
	<ul style="list-style-type: none"> during the 10 cycles test 2 x working voltage is connected between PRI and SEC 		N/A
	<ul style="list-style-type: none"> after 10 cycle test 2 transformers are subjected to the 17.2 test for 48 h and direct after the 48 h the dielectric strength test of 18.3 (100 % test voltage) is done 		N/A
	<ul style="list-style-type: none"> after the 10 cycle test the third sample is tested at the end of the last cycle in the hot position with the dielectric strength test of 18.3 (100 % test voltage) 		N/A
	<ul style="list-style-type: none"> the partial discharge test according to 18.101 is done after the cycling test and after the high voltage test, if the peak working voltage is >750 V 		N/A
27	RESISTANCE TO HEAT, FIRE AND TRACKING		P





IEC 61558-2-16			
Clause	Requirement + Test	Result - Remark	Verdict
27.1	General		P
27.2	Resistance to heat		P
27.2.1	All insulating parts are resistant to heat		P
	For parts of rubber, which passed the test of 19.9, no additional test is required.		N/A
	The tests are not required for cables and small connectors with a rated current ≤ 3 A, a rated voltage ≤ 24 V a.c. or 60 V d.c. and a power ≤ 72 W		P
27.2.2	External accessible parts		P
	The Ball-pressure test -: diameter of impression < 2 mm; heating cabinet temperature ($^{\circ}$ C) at 70 ± 2 $^{\circ}$ C or the temperature T of 14.1 ($T + 15 \pm 2$) - is fulfilled.	(See appended table)	P
27.2.3	Internal parts		P
	For insulating material retaining current carrying parts in position, the ball-pressure test -: diameter of impression < 2 mm; heating cabinet temperature ($^{\circ}$ C) at 125 ± 2 $^{\circ}$ C or the temperature T of 14.1 ($T + 15 \pm 2$) – is fulfilled	(See appended table)	P
27.3	Resistance to abnormal heat under fault conditions		N/A
27.4	Resistance to fire		P
27.4.1	All isolating parts of the transformer shall be resistant to ignition and spread of fire. The test according to IEC 60695-2-10 is required		P
27.4.2	External accessible parts (glow wire tests)		P
	– 650 $^{\circ}$ C for enclosures	Enclosure (no ignition)	P
	– 650 $^{\circ}$ C for parts retaining current carrying parts in position and terminals for external conductors Current $\leq 0,2$ A		N/A
	– 750 $^{\circ}$ C for parts retaining current carrying parts in position and terminals for external conductors with fixed wiring. Current $> 0,2$ A	Enclosure, plug holder, output connector (no ignition)	P
	– 850 $^{\circ}$ C for parts retaining current carrying parts in position and terminals for external conductors with non-fixed wiring. Current $> 0,2$ A	Enclosure, plug holder, output connector (no ignition)	P
27.4.3	Internal parts		P
	– 550 $^{\circ}$ C for internal insulating material – not retaining current carrying parts in position	Insulation sheet under PCB, Insulation sheet between primary and secondary circuit, heat shrinkable tube for F1 (no ignition)	P
	– 650 $^{\circ}$ C for coil formers (bobbins)	T1, LF1 bobbin, potting material (no ignition)	P
	– 650 $^{\circ}$ C for parts retaining current carrying parts in position and terminals for external conductors. Current $\leq 0,2$ A		N/A

IEC 61558-2-16			
Clause	Requirement + Test	Result - Remark	Verdict
	– 750 °C for parts retaining current carrying parts in position and terminals for external conductors with fixed wiring. Current > 0,2 A	T1 bobbin, LF1 bobbin, potting material (no ignition)	P
	– 850 °C for parts retaining current carrying parts in position and terminals for external conductors with non-fixed wiring. Current > 0,2 A	PCB, T1 bobbin, LF1 bobbin, potting material (no ignition)	P
27.5	For IP other than IPX0: If insulating parts retaining current carrying parts in position and under P3 conditions, the material resistance to tracking is at least material of group IIIb	IP20	N/A
	Material group IIIb ($100 \leq CTI \leq 175$) is not recommended for application in pollution degree 3 above 630V		N/A
	Test (175 V): no flashover or breakdown before 50 drops		N/A
28	RESISTANCE TO RUSTING		P
	Ferrous parts protected against rusting		P
E	ANNEX E , GLOW WIRE TEST		P
E.1	The test is required according to IEC 60695-2-10 and IEC 60695-2-11 with the following additions:		P
E.2	The requirements of 8.2, "Test temperatures" of IEC 60695-2-11:2014, apply with the temperature stated in 27.4 of IEC 61558-1		P
E.3	Clause 7, "Conditioning", of IEC 60695-2-11:2014 apply, preconditioning is required		P
E.4	Clause 8, "Test procedure", of IEC 60695-2-11:2014 apply, The tip of the glow wire is applied to the flat side of the surface.		P
F	ANNEX F, REQUIREMENTS FOR MANUALLY OPERATED SWITCHES WHICH ARE PARTS OF THE TRANSFORMER		N/A
F.2	Manually operated mechanical switches, tested as separate component, shall comply with IEC 61058:2016 under the conditions of F.2.		N/A
F.3	Manually operated mechanical switches tested as part of the transformer shall comply with the conditions specified under F.3		N/A
H	ANNEX H, ELECTRONIC CIRCUITS (IEC 61558-1)		P
H.1	For transformers including electronic circuits, the following requirements apply additionally to Clauses 5, 15, 26. This annex is not required for associated transformers		P
H.2	General notes on tests (addition to clause 5)		P
H.3	SHORT-CIRCUIT AND OVERLOAD PROTECTION (ADDITION TO CLAUSE 15)		P
H.3.1	Circuits designed and applied so that fault conditions do not render the appliance unsafe		P
	During and after each test:		P

IEC 61558-2-16			
Clause	Requirement + Test	Result - Remark	Verdict
	– temperatures do not exceed values specified in table 5		P
	– transformer complies with conditions specified in sub-clause 15.1		P
	If a conductor of a pcb becomes open circuited, the transformer is considered to have withstood the particular test, provided that all six conditions as specified are met		N/A
H.3.2	Fault conditions a) to f) of sub-clause H.3.3 are not tested if the following conditions are met:		N/A
	– electronic circuit is a low-power circuit as specified		N/A
	– safety of the appliance as specified does not rely on correct functioning of the electronic circuit		N/A
H.3.3	Fault conditions tested as specified when relevant:		P
	a) short-circuit of creepage distances and clearances, if less than specified in Cl. 26		P
	b) open circuit at the terminals of any component		N/A
	c) short-circuit of capacitors, unless they comply with IEC 60 384-14		P
	d) short-circuit of any two terminals of an electronic component as specified		P
	e) any failure of an integrated circuit as specified		P
	f) low-power circuit: low-power points are connected to the supply source		N/A
	Cl. 15 is repeated with a simulated fault as indicated in a) to e), if the transformer incorporates an electronic circuit to ensure compliance with Cl. 15		P
	Fault condition e) is applied for encapsulated and similar components		P
	PTC's and NTC's are not short-circuited if they are used as specified		N/A
H.3.4	If for a fuse-link complying with IEC 60 127-3 rated fuse current I1 is used, current I2 is measured as specified:	For fuse-link used condition	P
	– if $I_2 < 2,1 \times I_1$ test of 15.8 is repeated with fuse-link short-circuited		N/A
	– if $I_2 > 2,75 \times I_1$, no other tests are necessary		P
	If $I_2 > 2,1 \times I_1$ and $I_2 < 2,75 \times I_1$ test of 15.8 is repeated as specified		N/A
	For fuses other than those complying with IEC 60 127-3, the test is carried out as specified 15.3.2 to 15.3.5	For fusible resistor used condition; (See appended table)	P

IEC 61558-2-16			
Clause	Requirement + Test	Result - Remark	Verdict
H.4	CREEPAGE DISTANCES, CLEARANCES AND DISTANCES THROUGH INSULATION		P
H.4.1	For live parts separated by basic insulation smaller cr and cl as in 26 are allowed, if H.3 is fulfilled.		P
	In optocouplers no requirements of cr and cl		N/A
	For coatings annex W applies. Smaller distances as required in IEC 60664-3:2016, clause 4 are applicable,		N/A
	For potted transformers cycling tests acc, 26.2. are applicable		N/A
H.4.2	The ma. Surface temperature of optocouplers is 50 K		N/A
K	ANNEX K, INSULATED WINDING WIRES		P
K.1	Wire construction:		P
	<ul style="list-style-type: none"> insulated winding wire for basic or supplementary insulation (see 19.12.3) 		N/A
	<ul style="list-style-type: none"> insulated winding wire for reinforced insulation (see 19.12.3) 	Approved TIW used	P
	<ul style="list-style-type: none"> spliced circular winding wires and stranded winding wires with 0,05 to 5 mm diameter 		N/A
	<ul style="list-style-type: none"> spirally wrapped insulation – overlapping 		N/A
K.2	Type tests		N/A
K.2.1	General Tests between ambient temperature between 15° C and 35° C and at an humidity between 25% and 75 %		N/A
K.2.2	Electric strength test		N/A
K.2.2.1	Solid circular winding wires and stranded winding wires		N/A
	Test samples prepared according to clause 4.4.1 of IEC 60851-5:2008 (twisted pair)		N/A
	Dielectric strength test: 6 kV for reinforced insulation		N/A
	Dielectric strength test: 3 kV for basic or supplementary insulation		N/A
K.2.2.2	Square or rectangular wires.		N/A
	Test samples prepared according to clause 4.7.1 of IEC 60851-5:2008		N/A
	Dielectric strength test: 5,5 kV for reinforced insulation		N/A
	Dielectric strength test: 2,75 kV for basic or supplementary insulation		N/A
K.2.3	Flexibility and adherence		N/A

IEC 61558-2-16			
Clause	Requirement + Test	Result - Remark	Verdict
	Claus 5.1 in Test 8 of IEC 60851-3:2009 shall be used		N/A
	Test samples prepared according to clause 5.1.1.4 of IEC 60851-3:2009		N/A
	Dielectric strength test: 5,5 kV for reinforced insulation		N/A
	Dielectric strength test: 2,75 kV for basic or supplementary insulation		N/A
	Mandrel diameter according table K.1		N/A
	The tension to the wire during winding on mandrel is 118 N/mm ² (118 Mpa)		N/A
K.2.4	Heat shock		N/A
	Test samples prepared according to 3.2.1 (in Test 9) of IEC 60851-6:2012		N/A
	<ul style="list-style-type: none"> • high voltage test immediately after this test 		N/A
	<ul style="list-style-type: none"> • Dielectric strength test: 5,5 kV for reinforced insulation 		N/A
	<ul style="list-style-type: none"> • Dielectric strength test: 2,75 kV for basic or supplementary insulation 		N/A
K.2.5	Retention of dielectric strength after bending (test as specified under test 13 of 4.6.1 c) of IEC 60 851-5)		N/A
	<ul style="list-style-type: none"> • high voltage test immediately after this test 		N/A
	<ul style="list-style-type: none"> • Dielectric strength test: 5,5 kV for reinforced insulation 		N/A
	<ul style="list-style-type: none"> • Dielectric strength test: 2,75 kV for basic or supplementary insulation 		N/A
K.3	Testing during manufacturing		N/A
K.3.1	General Tests as subjected in K.3.2 and K.3.3		N/A
K.3.2	Routine test		N/A
	<ul style="list-style-type: none"> • Dielectric strength test: 4,2 kV for reinforced insulation 		N/A
	<ul style="list-style-type: none"> • Dielectric strength test: 2,1 kV for basic or supplementary insulation 		N/A
K.3.3	Sampling test		N/A
K.3.3.1	Solid circular winding wires and stranded winding wires		N/A
	Test with a twisted pair, prepared according clause 4.4.1 of IEC 60851-5:2008		N/A
	<ul style="list-style-type: none"> • Dielectric strength test: 6 kV for reinforced insulation 		N/A

IEC 61558-2-16			
Clause	Requirement + Test	Result - Remark	Verdict
	<ul style="list-style-type: none"> Dielectric strength test: 3 kV for basic or supplementary insulation 		N/A
K.3.3.2	Square or rectangular wire		N/A
	Samples prepared according to clause 4.7.1 of IEC 60851-5:2008		N/A
	<ul style="list-style-type: none"> Dielectric strength test: 5,5 kV for reinforced insulation 		N/A
	<ul style="list-style-type: none"> Dielectric strength test: 3 kV for basic or supplementary insulation 		N/A
V	ANNEX V, SYMBOLS TO BE USED FOR THERMAL CUT-OUTS		N/A
Figure V.1	Restored by manual operation 		N/A
Figure V.2	Restored by disconnection of the supply 		N/A
Figure V.3	Thermal link 		N/A
Figure V.4	Self-resetting thermal cut-out 		N/A

IEC 61558-2-16						
Clause	Requirement + Test			Result - Remark		Verdict
11 and 12	TABLE: OUTPUT VOLTAGE AND OUTPUT CURRENT UNDER LOAD; NO-LOAD OUTPUT VOLTAGE					P
Clause	11		12			
type/rated output/	rated voltage (V)	sec. voltage (V)	delta Usec (%)	Usec V no-load output	delta Usec no-load output %	further information
CZH015050 260EUWH with L1 (L1 model DR8*10) / 5.0VDC, 2.6A	100V/50Hz	4.92	-1.60%	5.07	3.05%	Limit: ±10%/±20%
	100V/60Hz	4.92	-1.60%	5.07	3.05%	Limit: ±10%/±20%
	240V/50Hz	4.90	-2.00%	5.04	2.86%	Limit: ±10%/±20%
	240V/60Hz	4.90	-2.00%	5.04	2.86%	Limit: ±10%/±20%
CZH015050 260EUWH with LF1 / 5.0VDC, 2.6A	100V/50Hz	4.91	-1.80%	5.06	3.05%	Limit: ±10%/±20%
	100V/60Hz	4.91	-1.80%	5.06	3.05%	Limit: ±10%/±20%
	240V/50Hz	4.89	-2.20%	5.04	3.07%	Limit: ±10%/±20%
	240V/60Hz	4.89	-2.20%	5.04	3.07%	Limit: ±10%/±20%
CZH015100 150EUWH with L1 (L1 model DR8*10) / 10.0VDC, 1.5A	100V/50Hz	9.97	-0.30%	10.04	0.70%	Limit: ±10%/±20%
	100V/60Hz	9.97	-0.30%	10.04	0.70%	Limit: ±10%/±20%
	240V/50Hz	9.98	-0.20%	10.04	0.60%	Limit: ±10%/±20%
	240V/60Hz	9.98	-0.20%	10.04	0.60%	Limit: ±10%/±20%
CZH015100 150EUWH with LF1 / 10.0VDC, 1.5A	100V/50Hz	9.95	-0.50%	10.04	0.90%	Limit: ±10%/±20%
	100V/60Hz	9.95	-0.50%	10.04	0.90%	Limit: ±10%/±20%
	240V/50Hz	9.97	-0.30%	10.05	0.80%	Limit: ±10%/±20%
	240V/60Hz	9.97	-0.30%	10.05	0.80%	Limit: ±10%/±20%
CZH015178 101EUWH with L1 (L1 model DR8*10) / 17.8VDC, 1.01A	100V/50Hz	17.92	0.67%	18.07	0.84%	Limit: ±10%/±20%
	100V/60Hz	17.92	0.67%	18.07	0.84%	Limit: ±10%/±20%
	240V/50Hz	17.93	0.73%	18.06	0.73%	Limit: ±10%/±20%
	240V/60Hz	17.93	0.73%	18.06	0.73%	Limit: ±10%/±20%
CZH015178 101EUWH with LF1 / 17.8VDC, 1.01A	100V/50Hz	17.92	0.67%	18.06	0.78%	Limit: ±10%/±20%
	100V/60Hz	17.92	0.67%	18.06	0.78%	Limit: ±10%/±20%
	240V/50Hz	17.92	0.67%	18.04	0.67%	Limit: ±10%/±20%
	240V/60Hz	17.92	0.67%	18.04	0.67%	Limit: ±10%/±20%
CZH015310 060EUWH with L1 (L1	100V/50Hz	31.04	0.13%	31.11	0.23%	Limit: ±10%/±20%
	100V/60Hz	31.04	0.13%	31.11	0.23%	Limit: ±10%/±20%

IEC 61558-2-16						
Clause	Requirement + Test				Result - Remark	Verdict
model DR8*10) / 31.0VDC, 0.6A	240V/50Hz	31.04	0.13%	31.12	0.26%	Limit: ±10%/±20%
	240V/60Hz	31.04	0.13%	31.12	0.26%	Limit: ±10%/±20%
CZH015310 060EUWH with LF1 / 31.0VDC, 0.6A	100V/50Hz	31.03	0.10%	31.10	0.23%	Limit: ±10%/±20%
	100V/60Hz	31.03	0.10%	31.10	0.23%	Limit: ±10%/±20%
	240V/50Hz	31.02	0.06%	31.11	0.29%	Limit: ±10%/±20%
	240V/60Hz	31.02	0.06%	31.11	0.29%	Limit: ±10%/±20%
CZH015420 044EUWH with L1 (L1 model DR8*10) / 42.0VDC, 0.44A	100V/50Hz	41.89	-0.26%	42.05	0.38%	Limit: ±10%/±20%
	100V/60Hz	41.89	-0.26%	42.05	0.38%	Limit: ±10%/±20%
	240V/50Hz	41.87	-0.31%	42.06	0.45%	Limit: ±10%/±20%
	240V/60Hz	41.87	-0.31%	42.06	0.45%	Limit: ±10%/±20%
CZH015420 044EUWH with L1 (L1 model AL0510) / 42.0VDC, 0.44A	100V/50Hz	41.80	-0.48%	42.05	0.60%	Limit: ±10%/±20%
	100V/60Hz	41.80	-0.48%	42.05	0.60%	Limit: ±10%/±20%
	240V/50Hz	41.90	-0.24%	42.04	0.33%	Limit: ±10%/±20%
	240V/60Hz	41.90	-0.24%	42.04	0.33%	Limit: ±10%/±20%
CZH015420 044EUWH with LF1 / 42.0VDC, 0.44A	100V/50Hz	41.87	-0.31%	42.04	0.41%	Limit: ±10%/±20%
	100V/60Hz	41.87	-0.31%	42.05	0.43%	Limit: ±10%/±20%
	240V/50Hz	41.86	-0.33%	42.06	0.48%	Limit: ±10%/±20%
	240V/60Hz	41.86	-0.33%	42.06	0.48%	Limit: ±10%/±20%
CZH015050 260EUWHL with L1 (L1 model DR8*10) / 5.0VDC, 2.6A	100V/50Hz	4.96	-0.80%	5.04	1.61%	Limit: ±10%/±20%
	100V/60Hz	4.96	-0.80%	5.04	1.61%	Limit: ±10%/±20%
	240V/50Hz	4.95	-1.00%	5.03	1.62%	Limit: ±10%/±20%
	240V/60Hz	4.95	-1.00%	5.03	1.62%	Limit: ±10%/±20%
CZH015050 260EUWHL with LF1 / 5.0VDC, 2.6A	100V/50Hz	4.94	-1.20%	5.03	1.82%	Limit: ±10%/±20%
	100V/60Hz	4.94	-1.20%	5.03	1.82%	Limit: ±10%/±20%
	240V/50Hz	4.93	-1.40%	5.01	1.62%	Limit: ±10%/±20%
	240V/60Hz	4.93	-1.40%	5.01	1.62%	Limit: ±10%/±20%
CZH015100 150EUWHL with L1 (L1 model DR8*10) / 10.0VDC, 1.5A	100V/50Hz	9.96	-0.40%	10.08	1.20%	Limit: ±10%/±20%
	100V/60Hz	9.96	-0.40%	10.08	1.20%	Limit: ±10%/±20%
	240V/50Hz	9.95	-0.50%	10.07	1.21%	Limit: ±10%/±20%
	240V/60Hz	9.95	-0.50%	10.07	1.21%	Limit: ±10%/±20%

IEC 61558-2-16							
Clause	Requirement + Test				Result - Remark		Verdict
CZH015100 150EUWHL with LF1 / 10.0VDC, 1.5A	100V/50Hz	9.94	-0.60%	10.07	1.31%	Limit: ±10%/±20%	
	100V/60Hz	9.94	-0.60%	10.07	1.31%	Limit: ±10%/±20%	
	240V/50Hz	9.93	-0.70%	10.05	1.21%	Limit: ±10%/±20%	
	240V/60Hz	9.93	-0.70%	10.05	1.21%	Limit: ±10%/±20%	
CZH015178 101EUWHL with L1 (L1 model DR8*10) / 17.8VDC, 1.01A	100V/50Hz	17.96	0.90%	18.05	0.50%	Limit: ±10%/±20%	
	100V/60Hz	17.96	0.90%	18.05	0.50%	Limit: ±10%/±20%	
	240V/50Hz	17.95	0.84%	18.04	0.50%	Limit: ±10%/±20%	
	240V/60Hz	17.95	0.84%	18.04	0.50%	Limit: ±10%/±20%	
CZH015178 101EUWHL with LF1 / 17.8VDC, 1.01A	100V/50Hz	17.94	0.79%	18.05	0.61%	Limit: ±10%/±20%	
	100V/60Hz	17.94	0.79%	18.05	0.61%	Limit: ±10%/±20%	
	240V/50Hz	17.94	0.79%	18.03	0.50%	Limit: ±10%/±20%	
	240V/60Hz	17.94	0.79%	18.03	0.50%	Limit: ±10%/±20%	
CZH015310 060EUWHL with L1 (L1 model DR8*10) / 31.0VDC, 0.6A	100V/50Hz	31.02	0.06%	31.19	0.55%	Limit: ±10%/±20%	
	100V/60Hz	31.02	0.06%	31.19	0.55%	Limit: ±10%/±20%	
	240V/50Hz	31.00	0.00%	31.17	0.55%	Limit: ±10%/±20%	
	240V/60Hz	31.00	0.00%	31.17	0.55%	Limit: ±10%/±20%	
CZH015310 060EUWHL with LF1 / 31.0VDC, 0.6A	100V/50Hz	31.01	0.03%	31.18	0.55%	Limit: ±10%/±20%	
	100V/60Hz	31.01	0.03%	31.18	0.55%	Limit: ±10%/±20%	
	240V/50Hz	30.99	-0.03%	31.16	0.55%	Limit: ±10%/±20%	
	240V/60Hz	30.99	-0.03%	31.16	0.55%	Limit: ±10%/±20%	
CZH015420 044EUWHL with L1 (L1 model DR8*10) / 42.0VDC, 0.44A	100V/50Hz	41.81	-0.45%	42.02	0.50%	Limit: ±10%/±20%	
	100V/60Hz	41.81	-0.45%	42.02	0.50%	Limit: ±10%/±20%	
	240V/50Hz	41.80	-0.48%	42.01	0.50%	Limit: ±10%/±20%	
	240V/60Hz	41.80	-0.48%	42.01	0.50%	Limit: ±10%/±20%	
CZH015420 044EUWHL with L1 (L1 model AL0510) / 42.0VDC, 0.44A	100V/50Hz	41.80	-0.48%	42.00	0.48%	Limit: ±10%/±20%	
	100V/60Hz	41.80	-0.48%	42.00	0.48%	Limit: ±10%/±20%	
	240V/50Hz	41.80	-0.48%	42.02	0.53%	Limit: ±10%/±20%	
	240V/60Hz	41.80	-0.48%	42.02	0.53%	Limit: ±10%/±20%	
CZH015420 044EUWHL with LF1 /	100V/50Hz	41.80	-0.48%	42.01	0.50%	Limit: ±10%/±20%	
	100V/60Hz	41.80	-0.48%	42.01	0.50%	Limit: ±10%/±20%	

IEC 61558-2-16						
Clause	Requirement + Test			Result - Remark		Verdict
42.0VDC, 0.44A	240V/50Hz	41.80	-0.48%	42.01	0.50%	Limit: ±10%/±20%
	240V/60Hz	41.80	-0.48%	42.01	0.50%	Limit: ±10%/±20%
CZH015420 044EUWF with L1 (L1 model DR8*10) / 42.0VDC, 0.44A	100V/50Hz	41.90	-0.24%	42.04	0.33%	Limit: ±10%/±20%
	100V/60Hz	41.90	-0.24%	42.04	0.33%	Limit: ±10%/±20%
	240V/50Hz	41.89	-0.26%	42.01	0.29%	Limit: ±10%/±20%
	240V/60Hz	41.89	-0.26%	42.01	0.29%	Limit: ±10%/±20%
CZH015420 044EUWF with L1 (L1 model AL0510) / 42.0VDC, 0.44A	100V/50Hz	41.90	-0.24%	42.02	0.29%	Limit: ±10%/±20%
	100V/60Hz	41.90	-0.24%	42.02	0.29%	Limit: ±10%/±20%
	240V/50Hz	41.90	-0.24%	42.00	0.24%	Limit: ±10%/±20%
	240V/60Hz	41.90	-0.24%	42.00	0.24%	Limit: ±10%/±20%
CZH015420 044EUWF with LF1 / 42.0VDC, 0.44A	100V/50Hz	41.89	-0.26%	42.03	0.33%	Limit: ±10%/±20%
	100V/60Hz	41.89	-0.26%	42.03	0.33%	Limit: ±10%/±20%
	240V/50Hz	41.88	-0.29%	42.01	0.31%	Limit: ±10%/±20%
	240V/60Hz	41.88	-0.29%	42.01	0.31%	Limit: ±10%/±20%
CZH015050 250EUUM with L1 (L1 model DR8*10) / 5.0VDC, 2.5A	100V/50Hz	4.92	-1.60%	5.03	2.24%	Limit: ±10%/±20%
	100V/60Hz	4.92	-1.60%	5.03	2.24%	Limit: ±10%/±20%
	240V/50Hz	4.91	-1.80%	5.00	1.83%	Limit: ±10%/±20%
	240V/60Hz	4.91	-1.80%	5.00	1.83%	Limit: ±10%/±20%
CZH015050 250EUUM with L1 (L1 model AL0510) / 5.0VDC, 2.5A	100V/50Hz	4.91	-1.80%	5.01	2.04%	Limit: ±10%/±20%
	100V/60Hz	4.91	-1.80%	5.01	2.04%	Limit: ±10%/±20%
	240V/50Hz	4.90	-2.00%	5.00	2.04%	Limit: ±10%/±20%
	240V/60Hz	4.90	-2.00%	5.00	2.04%	Limit: ±10%/±20%
CZH015050 250EUUM with LF1 / 5.0VDC, 2.5A	100V/50Hz	4.91	-1.80%	5.02	2.24%	Limit: ±10%/±20%
	100V/60Hz	4.91	-1.80%	5.02	2.24%	Limit: ±10%/±20%
	240V/50Hz	4.91	-1.80%	5.01	2.04%	Limit: ±10%/±20%
	240V/60Hz	4.91	-1.80%	5.01	2.04%	Limit: ±10%/±20%
CZH015050 260EUWA with L1 (L1 model DR8*10) / 5.0VDC, 2.6A	100V/50Hz	4.96	-0.80%	5.04	1.61%	Limit: ±10%/±20%
	100V/60Hz	4.96	-0.80%	5.04	1.61%	Limit: ±10%/±20%
	240V/50Hz	4.96	-0.80%	5.03	1.41%	Limit: ±10%/±20%
	240V/60Hz	4.96	-0.80%	5.03	1.41%	Limit: ±10%/±20%

IEC 61558-2-16						
Clause	Requirement + Test			Result - Remark		Verdict
CZH015050 260EUWA with LF1 / 5.0VDC, 2.6A	100V/50Hz	4.95	-1.00%	5.03	1.62%	Limit: $\pm 10\%/\pm 20\%$
	100V/60Hz	4.95	-1.00%	5.03	1.62%	Limit: $\pm 10\%/\pm 20\%$
	240V/50Hz	4.96	-0.80%	5.02	1.21%	Limit: $\pm 10\%/\pm 20\%$
	240V/60Hz	4.96	-0.80%	5.02	1.21%	Limit: $\pm 10\%/\pm 20\%$
CZH015100 150EUWA with L1 (L1 model DR8*10) / 10.0VDC, 1.5A	100V/50Hz	9.98	-0.20%	10.02	0.40%	Limit: $\pm 10\%/\pm 20\%$
	100V/60Hz	9.98	-0.20%	10.02	0.40%	Limit: $\pm 10\%/\pm 20\%$
	240V/50Hz	9.97	-0.30%	10.01	0.40%	Limit: $\pm 10\%/\pm 20\%$
	240V/60Hz	9.97	-0.30%	10.01	0.40%	Limit: $\pm 10\%/\pm 20\%$
CZH015100 150EUWA with LF1 / 10.0VDC, 1.5A	100V/50Hz	9.96	-0.40%	10.01	0.50%	Limit: $\pm 10\%/\pm 20\%$
	100V/60Hz	9.96	-0.40%	10.01	0.50%	Limit: $\pm 10\%/\pm 20\%$
	240V/50Hz	9.96	-0.40%	10.02	0.60%	Limit: $\pm 10\%/\pm 20\%$
	240V/60Hz	9.96	-0.40%	10.02	0.60%	Limit: $\pm 10\%/\pm 20\%$
CZH015178 101EUWA with L1 (L1 model DR8*10) / 17.8VDC, 1.01A	100V/50Hz	17.79	-0.06%	17.96	0.96%	Limit: $\pm 10\%/\pm 20\%$
	100V/60Hz	17.79	-0.06%	17.96	0.96%	Limit: $\pm 10\%/\pm 20\%$
	240V/50Hz	17.77	-0.17%	17.95	1.01%	Limit: $\pm 10\%/\pm 20\%$
	240V/60Hz	17.77	-0.17%	17.95	1.01%	Limit: $\pm 10\%/\pm 20\%$
CZH015178 101EUWA with LF1 / 17.8VDC, 1.01A	100V/50Hz	17.77	-0.17%	17.84	0.39%	Limit: $\pm 10\%/\pm 20\%$
	100V/60Hz	17.77	-0.17%	17.85	0.45%	Limit: $\pm 10\%/\pm 20\%$
	240V/50Hz	17.76	-0.22%	17.85	0.51%	Limit: $\pm 10\%/\pm 20\%$
	240V/60Hz	17.76	-0.22%	17.85	0.51%	Limit: $\pm 10\%/\pm 20\%$
CZH015310 060EUWA with L1 (L1 model DR8*10) / 31.0VDC, 0.6A	100V/50Hz	30.94	-0.19%	31.04	0.32%	Limit: $\pm 10\%/\pm 20\%$
	100V/60Hz	30.94	-0.19%	31.04	0.32%	Limit: $\pm 10\%/\pm 20\%$
	240V/50Hz	30.92	-0.26%	31.02	0.32%	Limit: $\pm 10\%/\pm 20\%$
	240V/60Hz	30.92	-0.26%	31.02	0.32%	Limit: $\pm 10\%/\pm 20\%$
CZH015310 060EUWA with LF1 / 31.0VDC, 0.6A	100V/50Hz	30.92	-0.26%	31.02	0.32%	Limit: $\pm 10\%/\pm 20\%$
	100V/60Hz	30.92	-0.26%	31.02	0.32%	Limit: $\pm 10\%/\pm 20\%$
	240V/50Hz	30.90	-0.32%	31.01	0.36%	Limit: $\pm 10\%/\pm 20\%$
	240V/60Hz	30.90	-0.32%	31.01	0.36%	Limit: $\pm 10\%/\pm 20\%$
CZH015420 044EUWA with L1 (L1	100V/50Hz	41.90	-0.24%	42.04	0.33%	Limit: $\pm 10\%/\pm 20\%$
	100V/60Hz	41.90	-0.24%	42.04	0.33%	Limit: $\pm 10\%/\pm 20\%$

IEC 61558-2-16						
Clause	Requirement + Test			Result - Remark		Verdict
model DR8*10) / 42.0VDC, 0.44A	240V/50Hz	41.90	-0.24%	42.01	0.26%	Limit: ±10%/±20%
	240V/60Hz	41.90	-0.24%	42.01	0.26%	Limit: ±10%/±20%
CZH015420 044EUWA with L1 (L1 model AL0510) / 42.0VDC, 0.44A	100V/50Hz	41.90	-0.24%	42.03	0.31%	Limit: ±10%/±20%
	100V/60Hz	41.90	-0.24%	42.03	0.31%	Limit: ±10%/±20%
	240V/50Hz	41.90	-0.24%	42.00	0.24%	Limit: ±10%/±20%
	240V/60Hz	41.90	-0.24%	42.00	0.24%	Limit: ±10%/±20%
CZH015420 044EUWA with LF1 / 42.0VDC, 0.44A	100V/50Hz	41.89	-0.26%	42.03	0.33%	Limit: ±10%/±20%
	100V/60Hz	41.89	-0.26%	42.03	0.33%	Limit: ±10%/±20%
	240V/50Hz	41.88	-0.29%	42.00	0.29%	Limit: ±10%/±20%
	240V/60Hz	41.88	-0.29%	42.00	0.29%	Limit: ±10%/±20%
CZH015050 260EUWQ with L1 (L1 model DR8*10) / 5.0VDC, 2.6A	100V/50Hz	4.96	-0.80%	5.07	2.22%	Limit: ±10%/±20%
	100V/60Hz	4.96	-0.80%	5.07	2.22%	Limit: ±10%/±20%
	240V/50Hz	4.95	-1.00%	5.06	2.22%	Limit: ±10%/±20%
	240V/60Hz	4.95	-1.00%	5.06	2.22%	Limit: ±10%/±20%
CZH015050 260EUWQ with LF1 / 5.0VDC, 2.6A	100V/50Hz	4.95	-1.00%	5.07	2.42%	Limit: ±10%/±20%
	100V/60Hz	4.95	-1.00%	5.07	2.42%	Limit: ±10%/±20%
	240V/50Hz	4.94	-1.20%	5.05	2.23%	Limit: ±10%/±20%
	240V/60Hz	4.94	-1.20%	5.05	2.23%	Limit: ±10%/±20%
CZH015100 150EUWQ with L1 (L1 model DR8*10) / 10.0VDC, 1.5A	100V/50Hz	9.88	-1.20%	10.07	1.92%	Limit: ±10%/±20%
	100V/60Hz	9.88	-1.20%	10.07	1.92%	Limit: ±10%/±20%
	240V/50Hz	9.86	-1.40%	10.04	1.83%	Limit: ±10%/±20%
	240V/60Hz	9.86	-1.40%	10.04	1.83%	Limit: ±10%/±20%
CZH015100 150EUWQ with LF1 / 10.0VDC, 1.5A	100V/50Hz	9.88	-1.20%	10.07	1.92%	Limit: ±10%/±20%
	100V/60Hz	9.88	-1.20%	10.07	1.92%	Limit: ±10%/±20%
	240V/50Hz	9.85	-1.50%	10.04	1.93%	Limit: ±10%/±20%
	240V/60Hz	9.85	-1.50%	10.04	1.93%	Limit: ±10%/±20%
CZH015178 101EUWQ with L1 (L1 model DR8*10) / 17.8VDC, 1.01A	100V/50Hz	17.72	-0.45%	17.95	1.30%	Limit: ±10%/±20%
	100V/60Hz	17.72	-0.45%	17.95	1.30%	Limit: ±10%/±20%
	240V/50Hz	17.70	-0.56%	17.97	1.53%	Limit: ±10%/±20%
	240V/60Hz	17.70	-0.56%	17.97	1.53%	Limit: ±10%/±20%

IEC 61558-2-16						
Clause	Requirement + Test				Result - Remark	Verdict
CZH015178 101EUWQ with LF1 / 17.8VDC, 1.01A	100V/50Hz	17.71	-0.51%	18.04	1.86%	Limit: ±10%/±20%
	100V/60Hz	17.71	-0.51%	18.04	1.86%	Limit: ±10%/±20%
	240V/50Hz	17.69	-0.62%	18.06	2.09%	Limit: ±10%/±20%
	240V/60Hz	17.69	-0.62%	18.06	2.09%	Limit: ±10%/±20%
CZH015310 060EUWQ with L1 (L1 model DR8*10) / 31.0VDC, 0.6A	100V/50Hz	30.96	-0.13%	31.04	0.26%	Limit: ±10%/±20%
	100V/60Hz	30.96	-0.13%	31.04	0.26%	Limit: ±10%/±20%
	240V/50Hz	30.94	-0.19%	31.08	0.45%	Limit: ±10%/±20%
	240V/60Hz	30.94	-0.19%	31.08	0.45%	Limit: ±10%/±20%
CZH015310 060EUWQ with LF1 / 31.0VDC, 0.6A	100V/50Hz	30.95	-0.16%	31.03	0.26%	Limit: ±10%/±20%
	100V/60Hz	30.95	-0.16%	31.03	0.26%	Limit: ±10%/±20%
	240V/50Hz	30.93	-0.23%	31.07	0.45%	Limit: ±10%/±20%
	240V/60Hz	30.93	-0.23%	31.07	0.45%	Limit: ±10%/±20%
CZH015420 044EUWQ with L1 (L1 model DR8*10) / 42.0VDC, 0.44A	100V/50Hz	41.86	-0.33%	41.99	0.31%	Limit: ±10%/±20%
	100V/60Hz	41.86	-0.33%	41.99	0.31%	Limit: ±10%/±20%
	240V/50Hz	41.84	-0.38%	41.98	0.33%	Limit: ±10%/±20%
	240V/60Hz	41.84	-0.38%	41.98	0.33%	Limit: ±10%/±20%
CZH015420 044EUWQ with L1 (L1 model AL0510) / 42.0VDC, 0.44A	100V/50Hz	41.80	-0.48%	41.97	0.41%	Limit: ±10%/±20%
	100V/60Hz	41.80	-0.48%	41.97	0.41%	Limit: ±10%/±20%
	240V/50Hz	41.80	-0.48%	41.96	0.38%	Limit: ±10%/±20%
	240V/60Hz	41.80	-0.48%	41.96	0.38%	Limit: ±10%/±20%
CZH015420 044EUWQ with LF1 / 42.0VDC, 0.44A	100V/50Hz	41.84	-0.38%	41.99	0.36%	Limit: ±10%/±20%
	100V/60Hz	41.84	-0.38%	41.99	0.36%	Limit: ±10%/±20%
	240V/50Hz	41.83	-0.40%	41.96	0.31%	Limit: ±10%/±20%
	240V/60Hz	41.83	-0.40%	41.96	0.31%	Limit: ±10%/±20%
CZH015050 300EUUG with L1 (L1 model AL0510) / 5.0VDC, 3.0A	100V/50Hz	4.94	-1.20%	5.03	1.82%	Limit: ±10%/±20%
	100V/60Hz	4.94	-1.20%	5.02	1.62%	Limit: ±10%/±20%
	240V/50Hz	4.92	-1.60%	5.02	2.03%	Limit: ±10%/±20%
	240V/60Hz	4.92	-1.60%	5.04	2.44%	Limit: ±10%/±20%
Supplementary information: Limit for clause 11 is ±10%, clause 12 is ±20%.						

IEC 61558-2-16						
Clause	Requirement + Test	Result - Remark				Verdict
14	TABLE: Heating Test					P
	Supply voltage (V)	90V, 60Hz Horizontal	90V, 60Hz Vertical	264V, 50Hz Horizontal	264V, 50Hz Vertical	—
	Ambient (°C)	35.0	35.0	35.0	35.0	—
Maximum measured temperature T of part/at.....:		T (°C)				max. temperature limit, (°C)
Model: CZH015420044EUWH with L1 (L1 model DR8*10) (PCB type A)						
Plug holder		62.7	61.5	56.3	55.9	Ref.
Insulation sheet		66.1	65.7	59.8	58.7	105
VR1		78.2	73.9	70.2	66.8	85
C1		89.1	86.3	80.5	77.6	105
L1		91.9	94.8	82.5	84.9	130
C2		91.1	92.0	81.9	83.0	105
PCB near U1		103.2	104.0	92.2	93.1	130
T1 winding		89.2	90.7	79.8	81.7	110
T1 core		86.8	87.4	77.6	78.8	110
CY1		80.2	83.5	71.6	74.7	125
C10		72.9	76.2	65.1	68.5	105
LF2 winding		71.5	74.0	64.4	66.2	130
Output wire		70.3	71.9	63.7	64.7	80
PCB near BD1		98.0	96.4	88.2	86.1	130
PCB near D3A		90.4	95.0	81.6	85.4	130
Enclosure inside near T1 top		79.7	81.2	71.1	72.9	Ref.
Enclose inside near T1 bottom		73.4	74.8	65.7	66.8	Ref.
Enclosure outside near T1 top		64.8	66.1	58.0	58.2	80
Enclosure outside near T1 bottom		60.7	63.1	55.6	53.7	80
Support		48.9	48.7	44.5	43.7	85
Ambient		35.0	35.0	35.0	35.0	--
Model: CZH015310060EUWH with L1 (L1 model DR8*10) (PCB type A)						
Plug holder		65.8	65.3	59.1	58.8	Ref.
Insulation sheet		75.7	71.7	67.8	63.8	105
VR1		76.9	75.0	69.2	67.1	85
C1		89.9	85.7	80.4	76.1	105
L1		99.3	94.1	88.5	84.1	130
C2		88.5	85.8	79.3	76.4	105
PCB near U1		105.4	103.3	93.6	92.2	130
T1 winding		99.7	101.3	88.9	90.7	110

IEC 61558-2-16					
Clause	Requirement + Test		Result - Remark		Verdict
T1 core	97.0	98.7	86.7	87.6	110
CY1	93.9	92.9	84.3	82.7	125
C10	74.0	78.4	65.9	69.9	105
LF2 winding	72.5	77.4	64.4	68.8	130
Output wire	68.8	71.6	61.4	64.4	80
PCB near BD1	105.1	107.5	93.6	95.5	130
PCB near D3A	101.0	101.8	89.8	90.8	130
Enclosure inside near T1 top	78.4	73.8	70.6	66.3	Ref.
Enclose inside near T1 bottom	73.8	76.1	65.7	68.1	Ref.
Enclosure outside near T1 top	64.0	65.8	57.1	58.9	80
Enclosure outside near T1 bottom	61.2	67.9	54.5	60.7	80
Support	47.2	46.2	43.0	41.2	85
Ambient	35.0	35.0	35.0	35.0	--
Model: CZH015178101EUWH with L1 (L1 model DR8*10) (PCB type A)					
Plug holder	66.2	65.8	59.5	59.8	Ref.
Insulation sheet	76.2	72.3	68.8	65.6	105
VR1	77.4	75.6	69.6	68.4	85
C1	90.5	86.4	81.3	77.4	105
L1	100.0	94.9	89.6	85.7	130
C2	89.1	86.5	79.8	77.8	105
PCB near U1	106.2	104.1	95.3	94.1	130
T1 winding	100.4	102.1	90.1	92.0	110
T1 core	97.7	99.5	87.7	89.9	110
CY1	94.6	93.7	84.9	84.8	125
C10	74.5	79.0	67.4	70.8	105
LF2 winding	73.0	78.0	65.8	70.1	130
Output wire	69.3	72.2	62.4	65.5	80
PCB near BD1	105.9	108.4	95.1	97.5	130
PCB near D3A	101.7	102.6	91.2	92.4	130
Enclosure inside near T1 top	79.0	74.4	71.3	67.3	Ref.
Enclose inside near T1 bottom	74.3	76.7	66.6	68.8	Ref.
Enclosure outside near T1 top	64.4	66.3	58.6	60.2	80
Enclosure outside near T1 bottom	61.6	68.4	55.8	61.8	80
Support	47.5	46.5	43.6	42.0	85
Ambient	35.0	35.0	35.0	35.0	--
Model: CZH015100150EUWH with L1 (L1 model DR8*10) (PCB type A)					
Plug holder	61.8	60.9	55.9	55.0	Ref.

IEC 61558-2-16					
Clause	Requirement + Test		Result - Remark		Verdict
Insulation sheet	65.2	65.0	59.0	58.9	105
VR1	77.2	73.2	69.9	66.7	85
C1	88.0	85.4	80.3	77.1	105
L1	90.7	93.9	82.1	84.9	130
C2	90.0	91.1	81.6	82.9	105
PCB near U1	102.0	103.0	93.0	93.2	130
T1 winding	88.1	89.8	79.7	81.7	110
T1 core	85.7	86.5	78.1	78.3	110
CY1	79.1	82.7	72.1	75.2	125
C10	71.9	75.4	65.9	68.4	105
LF2 winding	70.5	73.3	63.9	66.5	130
Output wire	69.3	71.2	62.7	64.7	80
PCB near BD1	96.8	95.4	87.5	86.6	130
PCB near D3A	89.3	94.1	80.7	85.4	130
Enclosure inside near T1 top	78.6	80.4	71.8	72.7	Ref.
Enclose inside near T1 bottom	72.4	74.1	65.8	67.6	Ref.
Enclosure outside near T1 top	67.3	67.0	57.2	54.6	80
Enclosure outside near T1 bottom	64.4	65.4	56.0	54.1	80
Support	48.1	48.2	43.8	44.3	85
Ambient	35.0	35.0	35.0	35.0	--
Model: CZH015050260EUWH with L1 (L1 model DR8*10) (PCB type A)					
Plug holder	62.3	59.3	57.6	54.8	Ref.
Insulation sheet	65.7	62.0	60.5	57.2	105
VR1	77.6	74.5	70.8	68.7	85
C1	88.4	85.1	81.4	78.1	105
L1	91.1	93.4	83.3	85.9	130
C2	90.4	85.2	83.4	78.5	105
PCB near U1	102.3	102.4	93.8	94.4	130
T1 winding	88.5	88.6	81.0	81.2	110
T1 core	86.1	85.5	79.5	79.0	110
CY1	79.6	81.0	72.8	74.8	125
C10	72.4	69.5	66.6	64.0	105
LF2 winding	71.0	75.1	65.2	69.1	130
Output wire	69.8	71.2	64.1	65.2	80
PCB near BD1	97.2	93.0	89.5	85.9	130
PCB near D3A	89.7	91.3	81.9	83.7	130
Enclosure inside near T1 top	79.1	73.4	72.3	68.0	Ref.

IEC 61558-2-16					
Clause	Requirement + Test		Result - Remark		Verdict
Enclose inside near T1 bottom	72.9	75.6	67.1	70.0	Ref.
Enclosure outside near T1 top	65.4	65.4	57.3	56.3	80
Enclosure outside near T1 bottom	63.6	64.0	55.8	55.1	80
Support	48.7	46.0	44.8	42.6	85
Ambient	35.0	35.0	35.0	35.0	--
Model: CZH015420044EUWHL with L1 (L1 model DR8*10) (PCB type B)					
Plug holder	65.1	68.0	59.3	61.3	Ref.
Insulation sheet	63.9	65.7	58.4	59.2	105
VR1	73.1	71.4	67.2	64.7	85
C1	87.1	85.1	79.4	77.4	105
L1	90.9	90.2	83.3	82.3	130
C2	77.4	77.8	71.1	71.0	105
PCB near U1	105.5	108.8	96.9	98.6	130
T1 winding	95.8	98.2	87.2	89.3	110
T1 core	94.3	96.5	86.2	87.5	110
CY1	79.4	83.1	72.8	75.0	125
C10	72.1	73.9	66.4	66.9	105
LF2 winding	83.1	87.1	75.7	79.2	130
Output wire	60.8	65.1	56.3	58.9	80
PCB near BD1	95.8	92.1	87.5	83.5	130
PCB near D3A	94.9	96.4	87.0	88.0	130
Enclosure inside near T1 top	79.3	79.8	72.6	72.5	Ref.
Enclose inside near T1 bottom	77.7	76.1	71.0	69.0	Ref.
Enclosure outside near T1 top	65.2	64.3	59.6	58.1	80
Enclosure outside near T1 bottom	63.3	66.1	57.8	60.0	80
Support	47.8	48.2	43.7	43.9	85
Ambient	35.0	35.0	35.0	35.0	--
Model: CZH015310060EUWHL with L1 (L1 model DR8*10) (PCB type B)					
Plug holder	64.9	64.5	58.6	59.1	Ref.
Insulation sheet	69.0	69.6	63.0	63.2	105
VR1	76.9	73.2	69.7	66.5	85
C1	88.9	90.3	80.4	82.0	105
L1	98.8	97.7	90.0	89.4	130
C2	78.8	80.9	71.8	73.9	105
PCB near U1	105.1	106.9	95.1	97.0	130
T1 winding	92.4	95.7	83.3	86.9	110
T1 core	90.1	93.9	82.1	85.2	110

IEC 61558-2-16						
Clause	Requirement + Test			Result - Remark		Verdict
CY1	87.2	88.4	78.8	80.9	125	
C10	73.5	78.9	66.6	72.2	105	
LF2 winding	87.3	89.4	79.2	81.4	130	
Output wire	67.5	68.8	61.1	63.4	80	
PCB near BD1	95.9	97.7	86.4	89.0	130	
PCB near D3A	101.6	103.8	92.5	94.9	130	
Enclosure inside near T1 top	78.4	78.9	71.0	71.8	Ref.	
Enclose inside near T1 bottom	75.9	75.2	68.9	68.3	Ref.	
Enclosure outside near T1 top	65.5	66.9	59.2	61.7	80	
Enclosure outside near T1 bottom	63.9	65.6	58.1	59.7	80	
Support	46.9	48.1	42.8	44.7	85	
Ambient	35.0	35.0	35.0	35.0	--	
Model: CZH015178101EUWHL with L1 (L1 model DR8*10) (PCB type B)						
Plug holder	66.9	66.5	61.0	61.1	Ref.	
Insulation sheet	71.1	71.7	64.2	65.6	105	
VR1	79.3	75.5	72.2	69.2	85	
C1	91.7	93.1	83.6	84.4	105	
L1	101.9	107.0	92.4	97.6	130	
C2	81.3	86.8	74.0	78.5	105	
PCB near U1	110.3	113.0	99.8	102.4	130	
T1 winding	95.3	100.3	86.4	91.1	110	
T1 core	92.9	97.9	84.1	89.4	110	
CY1	89.9	94.1	81.5	85.7	125	
C10	75.8	81.3	69.1	74.5	105	
LF2 winding	90.0	91.1	81.4	82.5	130	
Output wire	69.6	70.9	62.9	64.5	80	
PCB near BD1	98.9	100.8	90.1	91.1	130	
PCB near D3A	104.8	107.1	94.6	97.5	130	
Enclosure inside near T1 top	80.8	85.2	73.8	77.6	Ref.	
Enclose inside near T1 bottom	83.0	80.9	75.2	73.5	Ref.	
Enclosure outside near T1 top	67.5	69.1	61.4	63.5	80	
Enclosure outside near T1 bottom	65.9	67.4	59.8	61.3	80	
Support	48.3	49.5	44.5	45.8	85	
Ambient	35.0	35.0	35.0	35.0	--	
Model: CZH015100150EUWHL with L1 (L1 model DR8*10) (PCB type B)						
Plug holder	63.6	63.9	58.3	58.8	Ref.	
Insulation sheet	67.7	68.9	61.7	63.4	105	

IEC 61558-2-16						
Clause	Requirement + Test			Result - Remark		Verdict
VR1	75.4	72.4	68.2	66.2	85	
C1	87.1	89.3	78.6	81.0	105	
L1	96.8	98.3	87.7	89.4	130	
C2	77.2	79.4	70.6	72.3	105	
PCB near U1	108.0	108.8	97.8	99.1	130	
T1 winding	90.5	93.9	82.2	85.5	110	
T1 core	88.3	90.7	79.6	82.2	110	
CY1	85.4	89.5	77.1	81.8	125	
C10	72.1	78.1	65.0	71.1	105	
LF2 winding	85.5	94.5	77.5	86.0	130	
Output wire	66.2	68.1	60.5	62.3	80	
PCB near BD1	93.9	96.7	85.5	88.0	130	
PCB near D3A	99.5	102.7	90.3	93.9	130	
Enclosure inside near T1 top	76.8	80.7	70.2	74.0	Ref.	
Enclose inside near T1 bottom	78.9	74.4	71.3	68.3	Ref.	
Enclosure outside near T1 top	64.2	69.6	58.2	64.0	80	
Enclosure outside near T1 bottom	69.0	66.4	62.7	61.1	80	
Support	46.9	47.6	42.8	43.4	85	
Ambient	35.0	35.0	35.0	35.0	--	
Model: CZH015050260EUWHL with L1 (L1 model DR8*10) (PCB type B)						
Plug holder	63.2	63.4	56.9	57.3	Ref.	
Insulation sheet	67.1	68.4	60.6	62.4	105	
VR1	74.7	71.9	67.4	65.2	85	
C1	86.2	88.7	77.5	80.5	105	
L1	95.8	97.1	85.5	87.5	130	
C2	76.5	77.1	68.7	70.2	105	
PCB near U1	107.0	108.1	95.9	97.8	130	
T1 winding	89.6	90.8	79.8	81.8	110	
T1 core	87.4	87.9	78.2	79.1	110	
CY1	84.6	86.8	75.4	78.2	125	
C10	71.4	75.6	64.0	68.9	105	
LF2 winding	84.7	82.5	76.2	75.1	130	
Output wire	65.7	67.6	59.1	61.1	80	
PCB near BD1	93.0	96.0	83.5	86.4	130	
PCB near D3A	98.5	95.8	88.0	87.1	130	
Enclosure inside near T1 top	76.1	81.1	68.6	73.6	Ref.	
Enclose inside near T1 bottom	78.2	73.9	69.7	67.2	Ref.	

IEC 61558-2-16					
Clause	Requirement + Test		Result - Remark		Verdict
Enclosure outside near T1 top	63.7	69.1	57.7	62.3	80
Enclosure outside near T1 bottom	68.4	65.9	61.2	59.8	80
Support	46.7	47.3	42.0	43.5	85
Ambient	35.0	35.0	35.0	35.0	--
Model: CZH015420044EUWF with L1 (L1 model DR8*10) (PCB type C)					
Plug holder	63.9	65.7	57.7	55.3	Ref.
Insulation sheet	67.1	68.0	60.9	65.8	105
VR1	73.1	71.4	65.9	68.4	85
C1	87.1	85.1	78.6	82.2	105
L1	90.9	90.2	81.9	87.0	130
C2	77.4	77.8	70.1	74.4	105
PCB near U1	105.5	108.8	95.5	104.7	130
T1 winding	95.8	98.2	86.6	94.5	110
T1 core	94.3	96.5	85.2	92.2	110
CY1	79.4	83.1	71.6	79.7	125
C10	72.1	73.9	65.0	71.2	105
LF2 winding	83.1	87.1	75.5	84.0	130
Output wire	60.8	65.1	55.1	62.4	80
PCB near BD1	95.8	92.1	86.3	88.4	130
PCB near D3A	94.9	96.4	85.8	92.6	130
Enclosure inside near T1 top	77.3	74.8	70.0	72.3	Ref.
Enclose inside near T1 bottom	77.7	76.1	70.5	72.7	Ref.
Enclosure outside near T1 top	61.9	60.8	56.2	57.9	80
Enclosure outside near T1 bottom	63.3	66.1	57.0	63.1	80
Support	47.8	48.2	42.7	46.4	85
Ambient	35.0	35.0	35.0	35.0	--
Model: CZH015050250EUUM with L1 (L1 model DR8*10) (PCB type D)					
Plug holder	66.9	63.0	59.4	57.0	Ref.
Insulation sheet	68.1	63.7	60.6	57.8	105
VR1	77.6	73.5	68.6	66.0	85
C1	89.2	85.0	79.1	76.4	105
L1	87.7	90.5	77.2	81.2	130
C2	87.8	94.1	78.0	84.8	105
PCB near U1	107.6	106.6	95.6	96.2	130
T1 winding	96.5	96.2	85.5	86.7	110
T1 core	95.1	93.9	84.2	84.3	110
CY1	90.8	90.0	80.2	81.1	125

IEC 61558-2-16					
Clause	Requirement + Test		Result - Remark		Verdict
C10	88.7	84.2	78.8	75.4	105
LF2 winding	87.2	87.2	77.3	78.2	130
Output wire	71.4	69.9	63.6	63.4	80
PCB near BD1	89.4	91.8	78.9	82.5	130
PCB near D3A	93.6	98.2	83.0	88.1	130
Enclosure inside near T1 top	76.4	78.7	67.4	71.0	Ref.
Enclose inside near T1 bottom	78.1	73.7	69.2	65.8	Ref.
Enclosure outside near T1 top	67.9	69.4	60.6	62.1	80
Enclosure outside near T1 bottom	63.5	65.5	56.6	59.2	80
Support	47.8	48.1	42.9	43.9	85
Ambient	35.0	35.0	35.0	35.0	--
Model: CZH015420044EUWA with L1 (L1 model DR8*10) (PCB type E)					
Plug holder	67.4	66.5	61.2	60.9	Ref.
VR1	72.1	75.0	65.3	67.9	85
C1	85.3	89.5	77.6	81.6	105
L1	87.8	91.1	79.8	82.3	130
C2	86.3	87.3	78.4	78.7	105
PCB near U1	107.9	108.3	97.9	98.0	130
T1 winding	94.3	98.2	85.5	88.9	110
T1 core	92.7	98.0	84.5	88.3	110
CY1	82.6	86.6	74.8	79.0	125
C10	74.9	79.4	68.2	71.7	105
LF2 winding	87.6	80.3	79.6	73.1	130
Output wire	67.0	69.4	60.7	63.0	80
PCB near BD1	93.2	95.2	84.1	86.6	130
PCB near D3A	91.7	93.5	83.1	84.5	130
Enclosure inside near T1 top	75.7	76.7	68.5	69.2	Ref.
Enclose inside near T1 bottom	80.2	75.3	73.2	68.7	Ref.
Enclosure outside near T1 top	65.0	66.0	59.1	59.6	80
Enclosure outside near T1 bottom	66.3	67.2	60.3	61.0	80
Support	47.3	45.6	42.8	41.2	85
Ambient	35.0	35.0	35.0	35.0	--
Model: CZH015310060EUWA with L1 (L1 model DR8*10) (PCB type E)					
Plug holder	60.9	62.9	56.0	58.1	Ref.
VR1	74.2	79.3	67.9	73.3	85
C1	77.0	81.1	70.9	75.0	105
L1	86.0	85.4	78.9	79.0	130

IEC 61558-2-16					
Clause	Requirement + Test		Result - Remark		Verdict
C2	78.3	81.3	71.7	74.7	105
PCB near U1	99.8	103.4	92.4	95.0	130
T1 winding	93.5	95.4	86.0	87.5	110
T1 core	92.2	93.8	85.1	86.8	110
CY1	86.2	86.9	79.6	80.2	125
C10	89.1	85.4	82.5	79.0	105
LF2 winding	83.2	80.0	76.4	73.5	130
Output wire	65.6	62.7	60.8	57.7	80
PCB near BD1	89.5	95.0	82.3	87.2	130
PCB near D3A	93.6	92.1	86.2	85.3	130
Enclosure inside near T1 top	80.9	81.3	74.1	74.5	Ref.
Enclose inside near T1 bottom	78.4	78.8	72.7	72.4	Ref.
Enclosure outside near T1 top	68.0	67.1	62.7	61.8	80
Enclosure outside near T1 bottom	65.6	63.4	61.0	59.0	80
Support	46.9	47.0	43.5	43.9	85
Ambient	35.0	35.0	35.0	35.0	--
Model: CZH015178101EUWA with L1 (L1 model DR8*10) (PCB type E)					
Plug holder	65.4	66.3	60.7	61.3	Ref.
VR1	76.3	77.5	70.3	71.1	85
C1	84.0	88.0	77.2	80.9	105
L1	87.1	90.5	80.2	82.9	130
C2	86.1	84.5	79.2	78.2	105
PCB near U1	104.3	105.4	95.9	96.6	130
T1 winding	98.6	94.9	91.3	87.3	110
T1 core	96.0	93.0	88.6	85.3	110
CY1	90.8	83.9	84.1	77.8	125
C10	88.1	82.4	80.8	75.5	105
LF2 winding	99.1	96.4	91.7	89.0	130
Output wire	68.8	70.3	63.3	65.2	80
PCB near BD1	102.3	103.6	94.0	95.7	130
PCB near D3A	99.6	101.5	92.1	93.7	130
Enclosure inside near T1 top	83.0	81.7	76.2	75.4	Ref.
Enclose inside near T1 bottom	79.4	76.1	72.9	70.1	Ref.
Enclosure outside near T1 top	68.2	73.1	63.0	67.0	80
Enclosure outside near T1 bottom	70.7	68.1	65.5	63.3	80
Support	47.3	48.1	43.4	44.8	85
Ambient	35.0	35.0	35.0	35.0	--

IEC 61558-2-16					
Clause	Requirement + Test			Result - Remark	Verdict
Model: CZH015100150EUWA with L1 (L1 model DR8*10) (PCB type E)					
Plug holder	63.0	61.2	57.4	55.4	Ref.
VR1	75.8	75.3	68.6	68.1	85
C1	85.9	81.0	78.2	73.4	105
L1	90.4	86.3	81.7	78.4	130
C2	96.4	94.6	87.4	85.7	105
PCB near U1	98.9	97.6	89.9	88.4	130
T1 winding	89.4	86.8	81.0	79.0	110
T1 core	86.0	83.5	78.5	75.6	110
CY1	84.5	80.9	76.6	73.4	125
C10	94.3	95.5	85.2	86.5	105
LF2 winding	93.4	94.4	85.0	85.3	130
Output wire	72.5	72.2	65.8	65.4	80
PCB near BD1	93.6	91.8	84.9	83.2	130
PCB near D3A	95.1	93.8	86.6	84.9	130
Enclosure inside near T1 top	90.0	87.8	82.0	79.5	Ref.
Enclose inside near T1 bottom	84.0	80.5	76.0	73.4	Ref.
Enclosure outside near T1 top	75.2	70.6	68.3	64.6	80
Enclosure outside near T1 bottom	72.3	67.8	65.3	61.4	80
Support	46.9	46.9	42.5	43.0	85
Ambient	35.0	35.0	35.0	35.0	--
Model: CZH015050260EUWA with L1 (L1 model DR8*10) (PCB type E)					
Plug holder	63.0	61.2	56.2	54.2	Ref.
VR1	75.8	75.3	67.1	66.5	85
C1	85.9	81.0	76.0	71.7	105
L1	90.4	86.3	80.3	76.7	130
C2	86.4	81.4	76.4	72.0	105
PCB near U1	102.9	98.6	91.1	87.6	130
T1 winding	89.4	85.8	79.3	76.1	110
T1 core	86.0	83.5	76.3	73.8	110
CY1	84.5	80.9	75.3	71.7	125
C10	94.3	95.5	83.1	84.9	105
LF2 winding	93.4	94.4	82.7	83.4	130
Output wire	62.5	62.2	56.0	55.2	80
PCB near BD1	93.6	91.8	82.7	81.6	130
PCB near D3A	95.1	93.8	84.0	83.5	130
Enclosure inside near T1 top	80.0	77.8	70.5	68.7	Ref.

IEC 61558-2-16					
Clause	Requirement + Test		Result - Remark		Verdict
Enclose inside near T1 bottom	78.0	78.8	69.5	69.5	Ref.
Enclosure outside near T1 top	65.2	61.6	57.7	54.6	80
Enclosure outside near T1 bottom	62.3	61.0	55.5	54.4	80
Support	46.9	45.9	42.1	41.5	85
Ambient	35.0	35.0	35.0	35.0	--
Model: CZH015420044EUWQ with L1 (L1 model DR8*10) (PCB type A)					
Plug holder	67.4	65.3	61.8	59.0	Ref.
Insulation sheet	69.9	71.7	63.4	65.3	105
Input wire	64.3	63.7	58.7	58.4	80
VR1	76.1	77.1	69.3	70.4	85
C1	83.6	85.9	75.7	78.4	105
L1	96.7	98.3	87.9	88.9	130
C2	92.1	88.6	84.2	80.7	105
PCB near U1	108.4	105.6	98.8	95.7	130
T1 winding	96.5	98.2	87.3	89.2	110
T1 core	94.8	96.1	86.6	87.2	110
CY1	90.4	88.9	82.1	81.1	125
C10	70.1	72.1	63.8	65.6	105
LF2 winding	79.8	82.7	72.3	75.3	130
Output wire	68.0	71.3	61.6	65.2	80
PCB near BD1	96.4	93.7	87.2	84.8	130
PCB near D3A	92.2	93.3	83.9	84.5	130
Enclosure inside near T1 top	76.4	76.9	69.6	70.0	Ref.
Enclose inside near T1 bottom	75.0	76.1	67.8	69.0	Ref.
Enclosure outside near T1 top	62.4	66.1	57.1	60.2	80
Enclosure outside near T1 bottom	65.2	64.3	59.9	58.6	80
Support	47.4	48.5	43.7	44.0	85
Ambient	35.0	35.0	35.0	35.0	--
Model: CZH015310060EUWQ with L1 (L1 model DR8*10) (PCB type A)					
Plug holder	61.8	55.9	55.6	50.5	Ref.
Insulation sheet	72.3	73.5	65.0	66.4	105
Input wire	69.7	70.8	62.9	64.2	80
VR1	69.4	71.2	62.9	65.0	85
C1	90.2	86.1	81.3	78.7	105
L1	90.0	91.0	81.1	82.6	130
C2	94.6	95.6	85.1	86.7	105
PCB near U1	109.0	110.8	98.9	101.0	130

IEC 61558-2-16					
Clause	Requirement + Test		Result - Remark		Verdict
T1 winding	99.1	99.4	89.6	90.3	110
T1 core	96.6	95.4	87.4	86.5	110
CY1	87.5	89.2	78.8	80.5	125
C10	76.6	77.2	69.8	70.0	105
LF2 winding	74.1	74.1	66.9	67.2	130
Output wire	70.9	70.8	63.8	64.3	80
PCB near BD1	103.8	106.1	93.6	96.0	130
PCB near D3A	102.6	106.0	93.2	96.3	130
Enclosure inside near T1 top	76.2	74.0	69.5	67.5	Ref.
Enclose inside near T1 bottom	77.9	75.7	70.4	69.0	Ref.
Enclosure outside near T1 top	62.6	68.5	56.8	62.5	80
Enclosure outside near T1 bottom	67.2	65.3	60.6	59.3	80
Support	47.2	47.3	42.8	43.4	85
Ambient	35.0	35.0	35.0	35.0	--
Model: CZH015178101EUWQ with L1 (L1 model DR8*10) (PCB type A)					
Plug holder	74.1	69.6	65.8	62.3	Ref.
Insulation sheet	69.6	70.1	62.4	63.5	105
Input wire	63.3	61.8	56.4	56.2	80
VR1	77.5	73.5	68.8	65.9	85
C1	93.7	90.9	83.3	81.6	105
L1	97.9	98.8	87.3	88.2	130
C2	88.8	89.2	78.7	79.8	105
PCB near U1	110.2	107.0	98.4	96.0	130
T1 winding	102.4	99.4	90.6	88.7	110
T1 core	100.4	98.1	89.5	87.7	110
CY1	89.0	90.8	79.2	81.8	125
C10	72.3	72.4	64.2	65.5	105
LF2 winding	91.9	92.0	81.8	82.8	130
Output wire	67.1	67.0	59.5	60.6	80
PCB near BD1	103.7	99.2	91.9	88.7	130
PCB near D3A	105.7	108.9	94.4	97.4	130
Enclosure inside near T1 top	76.6	77.1	68.5	69.6	Ref.
Enclose inside near T1 bottom	79.8	76.8	71.3	69.1	Ref.
Enclosure outside near T1 top	69.7	66.9	62.3	60.0	80
Enclosure outside near T1 bottom	66.5	68.1	59.7	61.8	80
Support	47.1	48.0	41.8	44.0	85
Ambient	35.0	35.0	35.0	35.0	--

IEC 61558-2-16					
Clause	Requirement + Test			Result - Remark	Verdict
Model: CZH015100150EUWQ with L1 (L1 model DR8*10) (PCB type A)					
Plug holder	68.7	66.5	62.3	60.4	Ref.
Insulation sheet	71.0	70.7	64.4	64.2	105
Input wire	64.9	64.2	58.6	58.6	80
VR1	74.3	72.3	67.3	65.1	85
C1	85.9	88.9	77.8	80.3	105
L1	83.3	84.3	75.1	75.8	130
C2	92.1	93.5	82.9	84.4	105
PCB near U1	106.9	103.8	96.6	94.1	130
T1 winding	93.3	89.8	84.0	81.6	110
T1 core	91.0	88.4	82.6	79.5	110
CY1	87.7	86.7	79.7	78.9	125
C10	82.7	88.1	74.6	79.4	105
LF2 winding	82.9	86.4	74.9	78.4	130
Output wire	65.9	68.6	59.7	61.7	80
PCB near BD1	99.0	95.6	90.1	86.8	130
PCB near D3A	98.6	100.3	89.2	90.6	130
Enclosure inside near T1 top	85.1	83.3	76.9	75.6	Ref.
Enclose inside near T1 bottom	77.1	84.1	69.5	76.6	Ref.
Enclosure outside near T1 top	65.1	60.7	58.6	55.1	80
Enclosure outside near T1 bottom	61.7	68.2	56.1	61.8	80
Support	48.2	48.4	44.3	44.1	85
Ambient	35.0	35.0	35.0	35.0	--
Model: CZH015050260EUWQ with L1 (L1 model DR8*10) (PCB type A)					
Plug holder	64.9	63.0	58.5	57.1	Ref.
Insulation sheet	69.3	68.1	62.4	61.4	105
Input wire	66.5	61.9	59.9	55.5	80
VR1	77.6	73.5	70.4	65.7	85
C1	89.2	85.0	80.3	76.7	105
L1	97.7	101.4	88.1	90.7	130
C2	87.8	94.1	79.4	84.0	105
PCB near U1	103.6	106.6	93.5	95.2	130
T1 winding	96.5	96.2	86.8	86.4	110
T1 core	95.1	93.9	85.7	84.5	110
CY1	88.8	86.0	79.6	77.6	125
C10	88.7	84.2	79.4	75.6	105
LF2 winding	87.2	87.2	78.1	78.6	130

IEC 61558-2-16					
Clause	Requirement + Test		Result - Remark		Verdict
Output wire	71.4	69.9	64.5	62.7	80
PCB near BD1	89.4	91.8	80.9	82.5	130
PCB near D3A	93.6	98.2	84.4	87.9	130
Enclosure inside near T1 top	76.4	78.7	69.2	70.8	Ref.
Enclose inside near T1 bottom	78.1	73.7	70.8	66.8	Ref.
Enclosure outside near T1 top	67.9	69.4	61.0	62.7	80
Enclosure outside near T1 bottom	63.5	65.5	57.2	59.1	80
Support	47.8	48.1	43.0	43.9	85
Ambient	35.0	35.0	35.0	35.0	--
Model: CZH015178101EUWQG with L1 (L1 model DR8*10) (PCB type A)					
Plug holder	55.0	52.2	--	--	Ref.
Insulation sheet	56.1	56.9	--	--	105
Input wire	51.5	51.6	--	--	80
VR1	61.8	62.5	--	--	85
C1	68.0	68.7	--	--	105
L1	77.2	78.3	--	--	130
C2	74.5	71.4	--	--	105
PCB near U1	87.0	84.5	--	--	130
T1 winding	77.9	78.6	--	--	110
T1 core	77.0	77.3	--	--	110
CY1	72.7	71.7	--	--	125
C10	56.5	57.8	--	--	105
LF2 winding	64.3	66.2	--	--	130
Output wire	54.5	57.5	--	--	80
PCB near BD1	76.9	74.5	--	--	130
PCB near D3	73.9	74.9	--	--	130
Enclosure inside near T1 top	62.7	61.9	--	--	Ref.
Enclose inside near T1 bottom	59.5	60.7	--	--	Ref.
Enclosure outside near T1 top	50.9	53.0	--	--	80
Enclosure outside near T1 bottom	53.3	51.8	--	--	80
Support	38.3	38.5	--	--	85
Ambient	35.0	35.0	--	--	--
Model: CZH015050300EUUG with L1 (L1 model AL0510) (PCB type F)					
Plug holder	64.1	63.0	58.4	57.0	Ref.
C1	87.7	83.3	79.0	76.0	105
L1	92.6	88.4	82.9	80.7	130
C2	88.6	83.4	79.1	76.1	105

IEC 61558-2-16					
Clause	Requirement + Test		Result - Remark		Verdict
PCB near U1	115.7	110.3	103.1	100.2	130
T1 winding	101.6	99.0	90.8	90.2	110
T1 core	98.3	96.3	88.0	87.2	110
CY1	86.7	82.7	78.1	74.8	125
C10	96.0	98.6	86.0	89.4	105
PCB near DB1	95.7	94.5	86.4	85.5	130
PCB near U3	97.4	96.2	87.8	86.7	130
Enclosure inside near T1 top	92.3	90.6	82.8	82.5	Ref.
Enclose inside near T1 bottom	86.1	83.2	77.2	74.9	Ref.
Enclosure outside near T1 top	76.7	72.5	69.1	65.4	80
Enclosure outside near T1 bottom	73.6	69.8	66.9	64.1	80
Support	47.7	46.8	43.3	43.7	85
Ambient	35.0	35.0	35.0	35.0	--
Model: CZH015050260EUWHLG with LF1 (PCB type B)					
Plug holder (Inside)	53.9	54.5	50.1	49.6	Ref.
Input wire	67.9	67.9	57.3	57.1	80
VR1 body	73.5	73.5	61.2	60.8	85
PCB near BD1	79.4	80.1	62.6	61.5	130
LF1 winding	80.4	80.3	59.2	58.5	130
C1 body	63.3	62.7	54.8	54.9	105
C2 body	64.8	64.2	56.4	56.4	105
PCB near U1	82.4	83.6	76.2	75.8	130
T1 winding	85.1	83.9	78.6	79.6	110
T1 core	81.6	81.1	77.7	78.3	110
CY2 body	69.9	68.7	63.7	63.9	125
PCB near D3A	81.6	82.9	85.4	84.4	130
C8 body	67.0	67.9	69.6	68.9	105
LF2 winding	62.1	63.1	62.6	61.9	130
Output wire	59.7	60.1	59.6	59.5	80
Enclosure inside near T1	71.9	70.0	66.6	68.4	Ref.
Enclosure outside near T1	63.9	62.6	59.8	61.3	80
Support	42.2	43.2	41.0	40.1	85
Ambient	35.0	35.0	35.0	35.0	--
Model: CZH015420044EUWF with L1 (L1 model DR8*10) (PCB type G)					
Plug holder	--	63.9	--	--	Ref.
VR1	--	71.9	--	--	85
C1	--	85.5	--	--	105

IEC 61558-2-16					
Clause	Requirement + Test		Result - Remark		Verdict
L1	--	87.0	--	--	130
C2	--	83.8	--	--	105
PCB near U1	--	104.1	--	--	130
T1 winding	--	94.4	--	--	110
T1 core	--	94.3	--	--	110
CY1	--	82.8	--	--	125
C10	--	76.3	--	--	105
LF2 winding	--	77.1	--	--	130
Output wire	--	66.7	--	--	80
PCB near BD1	--	91.0	--	--	130
PCB near D3A	--	90.1	--	--	130
Enclosure inside near T1 top	--	73.8	--	--	Ref.
Enclose inside near T1 bottom	--	72.5	--	--	Ref.
Enclosure outside near T1 top	--	63.1	--	--	80
Enclosure outside near T1 bottom	--	64.5	--	--	80
Support	--	43.6	--	--	85
Ambient	--	35.0	--	--	--
Model: CZH015178101EUWH with LF1 (PCB type A)					
LF1 winding	95.7	90.6	--	--	130
Ambient	35.0	35.0	--	--	--
Model: CZH015178101EUWHL with LF1 (PCB type B)					
LF1 winding	96.6	100.0	--	--	130
Ambient	35.0	35.0	--	--	--
Model: CZH015420044EUWF with LF1 (PCB type C)					
LF1 winding	84.6	80.4	--	--	130
Ambient	35.0	35.0	--	--	--
Model: CZH015050260EUWQ with LF1 (PCB type A)					
LF1 winding	93.5	96.2	--	--	130
Ambient	35.0	35.0	--	--	--
Model: CZH015050250EUUM with LF1 (PCB type D)					
LF1 winding	82.4	87.1	--	--	130
Ambient	35.0	35.0	--	--	--
Model: CZH015420044EUWA with LF1 (PCB type E)					
LF1 winding	82.8	88.4	--	--	130
Ambient	35.0	35.0	--	--	--
Model: CZH015178101EUWH with L1 (L1 model AL0510) (PCB type A)					
L1	93.1	88.9	--	--	130

IEC 61558-2-16							
Clause	Requirement + Test				Result - Remark		Verdict
Ambient	35.0	35.0	--	--	--	--	--
Model: CZH015178101EUWHL with L1 (L1 model AL0510) (PCB type B)							
L1	93.8	98.8	--	--	--	--	130
Ambient	35.0	35.0	--	--	--	--	--
Model: CZH015420044EUWF with L1 (L1 model AL0510) (PCB type C)							
L1	85.9	84.7	--	--	--	--	130
Ambient	35.0	35.0	--	--	--	--	--
Model: CZH015050250EUUM with L1 (L1 model AL0510) (PCB type D)							
L1	79.1	84.6	--	--	--	--	130
Ambient	35.0	35.0	--	--	--	--	--
Model: CZH015050260EUWQ with L1 (L1 model AL0510) (PCB type A)							
L1	94.1	95.7	--	--	--	--	130
Ambient	35.0	35.0	--	--	--	--	--
Model: CZH015420044EUWA with L1 (L1 model AL0510) (PCB type E)							
L1	80.6	86.3	--	--	--	--	130
Ambient	35.0	35.0	--	--	--	--	--
Temperature T of winding:	t ₁ (°C)	R ₁ (Ω)	t ₂ (°C)	R ₂ (Ω)	T (°C)	Allowed T _{max} (°C)	Insulation class
--	--	--	--	--	--	--	--
Supplementary information: 1. Thermocouple method used. 2. T _{ma} is 35°C Max., above temperature data are fixed at ambient temperature 35°C. 3. Horizontal means the adaptor is plugged into horizontal socket-outlet; Vertical means the adaptor is plugged into vertical wall socket-outlet.							

15	TABLE: SHORT-CIRCUIT AND OVERLOAD PROTECTION							N/A
	ambient temperature (°C)							
type/rated output	r-cold Ω	r-warm Ω	temp. °C	ext. encl. °C	support °C	int. + ext. wire	further information	
--	--	--	--	--	--	--	--	

15	TABLE: Short circuit and overload protection			P
	Test voltage (V) :	264V/50Hz		—
	Ambient (°C) :	35.0		—
Thermocouple Locations		max. temperature measured, (°C)	max. temperature limit, (°C)	
Model: CZH015420044EUWH with L1 (PCB type A)				
T1 winding		86.2	165	
T1 core		83.7	165	
Output wire		69.2	85	
Enclosure outside near T1 top		63.2	105	

IEC 61558-2-16			
Clause	Requirement + Test	Result - Remark	Verdict
	Enclosure outside near T1 bottom	59.6	105
	Support	48.1	105
	Ambient	35.0	--
Model: CZH015310060EUWH with L1 (PCB type A)			
	T1 winding	95.4	165
	T1 core	93.4	165
	Output wire	66.2	85
	Enclosure outside near T1 top	62.0	105
	Enclosure outside near T1 bottom	58.9	105
	Support	46.6	105
	Ambient	35.0	--
Model: CZH015178101EUWH with L1 (PCB type A)			
	T1 winding	97.2	165
	T1 core	95.4	165
	Output wire	67.4	85
	Enclosure outside near T1 top	63.7	105
	Enclosure outside near T1 bottom	59.8	105
	Support	46.4	105
	Ambient	35.0	--
Model: CZH015100150EUWH with L1 (PCB type A)			
	T1 winding	84.8	165
	T1 core	82.9	165
	Output wire	66.8	85
	Enclosure outside near T1 top	60.5	105
	Enclosure outside near T1 bottom	60.1	105
	Support	46.2	105
	Ambient	35.0	--
Model: CZH015050260EUWH with L1 (PCB type A)			
	T1 winding	86.8	165
	T1 core	85.1	165
	Output wire	67.9	85
	Enclosure outside near T1 top	61.2	105
	Enclosure outside near T1 bottom	59.7	105
	Support	48.0	105
	Ambient	35.0	--
Model: CZH015420044EUWHL with L1 (PCB type B)			
	T1 winding	97.0	165
	T1 core	95.0	165
	Output wire	64.1	85
	Enclosure outside near T1 top	63.2	105
	Enclosure outside near T1 bottom	64.6	105

IEC 61558-2-16			
Clause	Requirement + Test	Result - Remark	Verdict
Support		47.5	105
Ambient		35.0	--
Model: CZH015310060EUWHL with L1 (PCB type B)			
T1 winding		92.9	165
T1 core		91.2	165
Output wire		67.5	85
Enclosure outside near T1 top		65.6	105
Enclosure outside near T1 bottom		63.9	105
Support		47.1	105
Ambient		35.0	--
Model: CZH015178101EUWHL with L1 (PCB type B)			
T1 winding		97.8	165
T1 core		95.6	165
Output wire		68.7	85
Enclosure outside near T1 top		67.7	105
Enclosure outside near T1 bottom		65.3	105
Support		48.9	105
Ambient		35.0	--
Model: CZH015100150EUWHL with L1 (PCB type B)			
T1 winding		87.5	165
T1 core		84.8	165
Output wire		64.6	85
Enclosure outside near T1 top		61.8	105
Enclosure outside near T1 bottom		66.6	105
Support		45.6	105
Ambient		35.0	--
Model: CZH015050260EUWHL with L1 (PCB type B)			
T1 winding		84.3	165
T1 core		82.7	165
Output wire		62.6	85
Enclosure outside near T1 top		61.0	105
Enclosure outside near T1 bottom		64.5	105
Support		44.2	105
Ambient		35.0	--
Model: CZH015420044EUWF with L1 (PCB type C)			
T1 winding		102.6	165
T1 core		100.2	165
Output wire		67.3	85
Enclosure outside near T1 top		62.7	105
Enclosure outside near T1 bottom		68.6	105
Support		50.2	105

IEC 61558-2-16			
Clause	Requirement + Test	Result - Remark	Verdict
Ambient		35.0	--
Model: CZH015050250EUUM with L1 (PCB type D)			
T1 winding		91.1	165
T1 core		87.4	165
Output wire		68.6	85
Enclosure outside near T1 top		65.7	105
Enclosure outside near T1 bottom		61.2	105
Support		46.3	105
Ambient		35.0	--
Model: CZH015420044EUWA with L1 (PCB type E)			
T1 winding		98.5	165
T1 core		96.2	165
Output wire		68.8	85
Enclosure outside near T1 top		64.9	105
Enclosure outside near T1 bottom		65.6	105
Support		44.0	105
Ambient		35.0	--
Model: CZH015310060EUWA with L1 (PCB type E)			
T1 winding		93.0	165
T1 core		92.3	165
Output wire		64.8	85
Enclosure outside near T1 top		66.7	105
Enclosure outside near T1 bottom		65.2	105
Support		46.3	105
Ambient		35.0	--
Model: CZH015178101EUWA with L1 (PCB type E)			
T1 winding		97.2	165
T1 core		94.7	165
Output wire		70.0	85
Enclosure outside near T1 top		71.9	105
Enclosure outside near T1 bottom		67.7	105
Support		48.3	105
Ambient		35.0	--
Model: CZH015100150EUWA with L1 (PCB type E)			
T1 winding		88.1	165
T1 core		85.2	165
Output wire		70.9	85
Enclosure outside near T1 top		74.1	105
Enclosure outside near T1 bottom		71.0	105
Support		45.4	105
Ambient		35.0	--

IEC 61558-2-16			
Clause	Requirement + Test	Result - Remark	Verdict
Model: CZH015050260EUWA with L1 (PCB type E)			
	T1 winding	85.6	165
	T1 core	82.2	165
	Output wire	61.1	85
	Enclosure outside near T1 top	62.5	105
	Enclosure outside near T1 bottom	60.2	105
	Support	45.3	105
	Ambient	35.0	--
Model: CZH015420044EUWQ with L1 (PCB type A)			
	Input wire	62.4	165
	T1 winding	95.0	165
	T1 core	93.3	85
	Output wire	69.8	105
	Enclosure outside near T1 top	63.7	105
	Enclosure outside near T1 bottom	62.2	105
	Support	46.6	--
	Ambient	35.0	--
Model: CZH015310060EUWQ with L1 (PCB type A)			
	Input wire	68.2	165
	T1 winding	96.7	165
	T1 core	93.2	85
	Output wire	68.6	105
	Enclosure outside near T1 top	67.3	105
	Enclosure outside near T1 bottom	63.2	105
	Support	46.0	--
	Ambient	35.0	--
Model: CZH015178101EUWQ with L1 (PCB type A)			
	Input wire	60.6	85
	T1 winding	97.0	165
	T1 core	96.0	165
	Output wire	63.8	85
	Enclosure outside near T1 top	66.5	105
	Enclosure outside near T1 bottom	63.7	105
	Support	44.4	105
	Ambient	35.0	--
Model: CZH015100150EUWQ with L1 (PCB type A)			
	Input wire	63.5	85
	T1 winding	91.5	165
	T1 core	89.2	165
	Output wire	66.9	85
	Enclosure outside near T1 top	63.9	105

IEC 61558-2-16			
Clause	Requirement + Test	Result - Remark	Verdict
Enclosure outside near T1 bottom	60.3		105
Support	47.9		105
Ambient	35.0		--
Model: CZH015050260EUWQ with L1 (PCB type A)			
Input wire	64.2		85
T1 winding	93.4		165
T1 core	92.4		165
Output wire	68.9		85
Enclosure outside near T1 top	65.7		105
Enclosure outside near T1 bottom	61.7		105
Support	46.5		105
Ambient	35.0		--
Model: CZH015050300EUUG with L1 (PCB type F)			
T1 winding	98.0		165
T1 core	94.4		165
Enclosure outside near T1 top	74.5		105
Enclosure outside near T1 bottom	72.2		105
Support	46.4		105
Ambient	35.0		--
Supplementary information: 1. All the conditions were considered for clause 15, and also Max. temperature with rated 1.1 times voltage during test output overload for recorded as above. 2. The above temperature data are fixed at ambient temperature 35°C. 3. Thermocouple method used. 4. Limited temperature for winding is 165°C (Class B) under 35°C ambient. 5. When short-circuited output terminals for above models, unit shut down, no output, no hazard.			

18.2	TABLE: insulation resistance measurements	P	
Insulation resistance R between:	R (MΩ)	Required R (MΩ)	
Between mains poles (F1 disconnected) (BI) @	>500	2	
Insulation sheet under PCB (All sources) (BI)	>500	2	
Heat shrinkable tube for EC2 (All sources) (BI)	>500	2	
Between primary live parts and output circuit (RI) @	>500	5	
Between primary live parts and external enclosure with metal foil (RI) @	>500	7	
Between primary winding and secondary winding of transformer (RI)	>500	5	
Between iron core and secondary winding of transformer (RI)	>500	5	
Insulation sheet between primary and secondary circuit (All sources) (For models CZH015050yyymmUGa)	>500	5	
Between two metal foils in contact with the inner and outer surfaces of enclosures (RI) @	>500	7	

IEC 61558-2-16			
Clause	Requirement + Test	Result - Remark	Verdict

Supplementary information:
BI: Basic insulation; RI: Reinforced insulation.
@ refer to "Summary of testing" for details of testing models.

18.3	TABLE: Dielectric Strength		P
Test voltage applied between:	Test potential applied (V)	Breakdown / flashover (Yes/No)	
Between mains poles (F1 disconnected) (BI) @	1400VAC	No	
Insulation sheet under PCB (All sources) (BI)	1440VAC	No	
Heat shrinkable tube for EC2 (All sources) (BI)	1440VAC	No	
Between primary live parts and output circuit (RI) @	2870VAC	No	
Between primary live parts and external enclosure with metal foil (RI) @	2870VAC	No	
Between primary winding and secondary winding of transformer (RI)	2870VAC	No	
Between iron core and secondary winding of transformer (RI)	2870VAC	No	
Insulation sheet between primary and secondary circuit (All sources) (For models CZH015050yyymmUGa)	2870VAC	No	

Supplementary information:
BI: Basic insulation; RI: Reinforced insulation.
@ refer to "Summary of testing" for details of testing models.

20	TABLE: Critical components information				P
Object / part No.	Manufacturer/ trademark	Type / model	Technical data	Standard	Mark(s) of conformity ¹⁾
Plastic enclosure	SABIC INNOVATIVE PLASTICS US L L C	940(f1)(gg*)	V-0, 120°C, min. 2.0mm thickness	UL 94, IEC/EN IEC 61558-1, IEC/EN 61558-2-16	UL, Tested with appliance
Plug holder	SABIC INNOVATIVE PLASTICS US L L C	940(f1)(gg*)	V-0, 120°C	UL 94, IEC/EN IEC 61558-1, IEC/EN 61558-2-16	UL, Tested with appliance
Insulation sheet under PCB	DUPONT TEIJIN FILMS U S L P	Mylar A, AP, EL121, MO21	VTM-2, 105°C, min. 0.4mm thickness	UL 94, UL 746C, IEC/EN IEC 61558-1, IEC/EN 61558-2-16	UL, Tested with appliance
(Alternative)	SICHUAN DONGFANG INSULATING MATERIAL CO LTD	DF6025	VTM-0, 105°C, min. 0.4mm thickness	UL 94, UL 746C, IEC/EN IEC 61558-1, IEC/EN 61558-2-16	UL, Tested with appliance

IEC 61558-2-16					
Clause	Requirement + Test			Result - Remark	Verdict
Insulation sheet between primary and secondary circuit (For models CZH015050yyymm UGa)	SICHUAN DONGFANG INSULATING MATERIAL CO LTD	DFR116ECO A, DFR116ECOB, DFR116ECOC	V-0, 80°C, min. 0.9mm thickness	UL 94, UL 746C, IEC/EN IEC 61558-1, IEC/EN 61558-2-16	UL, Tested with appliance
PCB	DONGGUAN SHI XINYANG ELECTRONIC CO LTD	XY-V, XY-C	V-0, 130°C	UL 796, IEC/EN IEC 61558-1, IEC/EN 61558-2-16	UL, Tested with appliance
(Alternative)	DONGGUAN CITY XINRAN ELECTRONIC CO LTD	XR-V002, XR-F003	V-0, 130°C	UL 796, IEC/EN IEC 61558-1, IEC/EN 61558-2-16	UL, Tested with appliance
(Alternative)	BOLUO EVERSUN ELECTRONICS PLANT	YY-VK10, YY-VZ10, YY-CK11, YY-CZ11	V-0, 130°C	UL 796, IEC/EN IEC 61558-1, IEC/EN 61558-2-16	UL, Tested with appliance
(Alternative)	DONGGUAN CITY TONSUN ELECTRONIC CO LTD	TS-02, TS-03	V-0, 130°C	UL 796, IEC/EN IEC 61558-1, IEC/EN 61558-2-16	UL Tested with appliance
(Alternative)	SHANDONG JINBAO TECH-INNOV CORPORATION	ZD-90F, ZD-95(G)F	V-0, 130°C	UL 796, IEC/EN IEC 61558-1, IEC/EN 61558-2-16	UL, Tested with appliance
Fuse or fusible resistor (F1)	Shenzhen Lanson Electronics Co. Ltd.	3N	T2A, 250VAC	IEC/EN 60127-1, IEC/EN 60127-3, UL 248-1, UL 248-14	VDE, UL
(Alternative)	Dongguan Hongda Electronic Technology Co., Ltd.	31TC	T2A, 250VAC	IEC/EN 60127-1, IEC/EN 60127-3, UL 248-1, UL 248-14	VDE, UL
(Alternative)	Dongguan Hongda Electronic Technology Co., Ltd.	31TD	T2A, 250VAC	IEC/EN 60127-1, IEC/EN 60127-3, UL 248-1, UL 248-14	VDE, UL
(Alternative)	Dongguan Hongda Electronic Technology Co., Ltd.	31FD	T2A, 250VAC	IEC/EN 60127-1, IEC/EN 60127-3, UL 248-1, UL 248-14	VDE, UL

IEC 61558-2-16					
Clause	Requirement + Test			Result - Remark	Verdict
(Alternative)	XC Electronics (Shen Zhen) Corp. Ltd.	3T	T2A, 250VAC	IEC/EN 60127-1, IEC/EN 60127-3, UL 248-1, UL 248-14	VDE, UL
(Alternative)	Shenzhen Great Electronics Co. Ltd.	RXF	1ohm, 2W	IEC/EN IEC 61558-1, IEC/EN 61558-2-16	Tested with appliance
(Alternative)	Dongguan Hongda Electronic Technology Co., Ltd.	RXF	1ohm, 2W	IEC/EN IEC 61558-1, IEC/EN 61558-2-16	Tested with appliance
(Alternative)	Shenzhen Yingfa Electronics CO. LTD.	RXF	1ohm, 2W	IEC/EN IEC 61558-1, IEC/EN 61558-2-16	Tested with appliance
(Alternative)	Shenzhen Lanbao Anke Electronics CO., LTD	RXF 21	1ohm, 2W	IEC/EN IEC 61558-1, IEC/EN 61558-2-16	Tested with appliance
Heat shrinkable tube (Used for F1 for all models and for EC2 of models CZH015050yyymm UGa)	SHENZHEN WOER HEAT-SHRINKABLE MATERIAL CO LTD	RSFR, RSFR-H	Min. 300V, min. 125°C, VW-1, min. thickness 0.2mm	UL 224, IEC/EN IEC 61558-1, IEC/EN 61558-2-16	UL, Tested with appliance
(Alternative)	DONG GUAN HUANG FENG INSULATION MATERIAL CO LTD	HFT-2	Min. 300V, min. 125°C, VW-1, min. thickness 0.2mm	UL 224, IEC/EN IEC 61558-1, IEC/EN 61558-2-16	UL, Tested with appliance
(Alternative)	SHENZHEN WOLIDA TRADING CO LTD	RSFR-H, RSFR(CB)	Min. 300V, min. 125°C, VW-1, min. thickness 0.2mm	UL 224, IEC/EN IEC 61558-1, IEC/EN 61558-2-16	UL, Tested with appliance
(Alternative)	CHANGYUAN ELECTRONICS GROUP CO LTD	CB-HFT*, CB-HFT(XY)*, CYG-MT*	Min. 300V, min. 125°C, VW-1, thickness min. 0.2mm	UL 224, IEC/EN IEC 61558-1, IEC/EN 61558-2-16	UL, Tested with appliance
(Alternative)	3M COMPANY ELECTRICAL MARKETS DIV (EMD)	SFTW-A VW1, HFT VW1	Min. 300V, min. 125°C, VW-1, thickness min. 0.2mm	UL 224, IEC/EN IEC 61558-1, IEC/EN 61558-2-16	UL, Tested with appliance

IEC 61558-2-16					
Clause	Requirement + Test			Result - Remark	Verdict
Varistor (RV1) (Optional)	Shantou High- New Technology Dev. Zone Songtian Enterprise Co., Ltd.	10D471K, 10D561K, 10D681K, 14D471K, 14D561K, 14D681K	Min. 300VAC, min. 85°C, V-0 coating	IEC/EN 61051-1, IEC/EN 61051- 2+A1, IEC/EN 61051-2- 2, UL 1449	VDE, UL
(Alternative)	Shaanxi Huaxing electronic group Co., Ltd.	MYG20G10K47 1, MYG20G10K56 1, MYG20G10K68 1, MYG20G14K47 1, MYG20G14K56 1, MYG20G14K68 1	Min. 300VAC, min. 85°C, V-0 coating	IEC/EN 61051-1, IEC/EN 61051- 2+A1, IEC/EN 61051-2- 2, UL 1449	VDE, UL
(Alternative)	Cerglass MFG Inc	10D471K, 10D561K, 10D681K, 14D471K, 14D561K, 14D681K	Min. 300VAC, min. 85°C, V-0 coating	IEC/EN 61051-1, IEC/EN 61051- 2+A1, IEC/EN 61051-2- 2, UL 1449	VDE, UL
(Alternative)	Thinking Electronic Industrial Co., Ltd.	TVR10471, TVR10511, TVR10561, TVR10681, TVR10471-V, TVR10511-V, TVR10561-V, TVR10681-V, TVR10471-B, TVR10511-B, TVR10561-B, TVR10681-B, TVR14471, TVR14511, TVR14561, TVR14681, TVR14471-V, TVR14511-V, TVR14561-V, TVR14681-V	Min. 300VAC, min. 85°C, V-0 coating	IEC/EN 61051-1, IEC/EN 61051- 2+A1, IEC/EN 61051-2- 2, UL 1449	VDE, UL
(Alternative)	Success Electronics Co., Ltd.	SVR10D471K, SVR10D511K, SVR10D561K, SVR10D681K, SVR14D471K, SVR14D511K, SVR14D561K, SVR14D681K	Min. 300VAC, min. 85°C, V-0 coating	IEC/EN 61051-1, IEC/EN 61051- 2+A1, IEC/EN 61051-2- 2, UL 1449	VDE, UL

IEC 61558-2-16					
Clause	Requirement + Test			Result - Remark	Verdict
(Alternative)	Centra Science Corp.	CNR-10D471K, CNR-10D511K, CNR-10D561K, CNR-10D681K, CNR-14D471K, CNR-14D511K, CNR-14D561K, CNR-14D681K	Min. 300VAC, min. 85°C, V-0 coating	IEC/EN 61051-1, IEC/EN 61051- 2+A1, IEC/EN 61051-2- 2, UL 1449	VDE, UL
(Alternative)	Joyin Co., Ltd.	10N471K, 10N511K, 10N561K, 10N681K, 14N471K, 14N511K, 14N561K, 14N681K	Min. 300VAC, min. 85°C, V-0 coating	IEC/EN 61051-1, IEC/EN 61051- 2+A1, IEC/EN 61051-2- 2, UL 1449	VDE, UL
(Alternative)	HuiZhou Lien Shun Electronic Co., Ltd.	10D471K, 10D511K, 10D561K, 10D681K, 14D471K, 14D511K, 14D561K, 14D681K	Min. 300VAC, min. 85°C, V-0 coating	IEC/EN 61051-1, IEC/EN 61051- 2+A1, IEC/EN 61051-2- 2	VDE
(Alternative)	Guangdong South Hongming Electronic Science and Technology Co., Ltd.	ZVR10D471K, ZVR10D511K, ZVR10D561K, ZVR10D681K, ZVR14D471K, ZVR14D511K, ZVR14D561K, ZVR14D681K	Min. 300VAC, min. 85°C, V-0 coating	IEC/EN 61051-1, IEC/EN 61051- 2+A1, IEC/EN 61051-2- 2, UL 1449	VDE, UL
(Alternative)	Hongzhi Enterprises Ltd.	HEL10D471K, HEL10D511K, HEL10D561K, HEL10D681K, HEL14D471K, HEL14D511K, HEL14D561K, HEL14D681K	Min. 300VAC, min. 85°C, V-0 coating	IEC/EN 61051-1, IEC/EN 61051- 2+A1, IEC/EN 61051-2- 2, UL 1449	VDE, UL
Choke (L1) (For models CZH015050yyymm UGa only)	Huizhou Jinmei Technology Co., Ltd.	AL0510	130°C	IEC/EN IEC 61558-1, IEC/EN 61558-2- 16	Tested with appliance
(Alternative)	Shenzhen Jingchengyuan Electronics Co., Ltd.	AL0510	130°C	IEC/EN IEC 61558-1, IEC/EN 61558-2- 16	Tested with appliance

IEC 61558-2-16					
Clause	Requirement + Test			Result - Remark	Verdict
Choke (L1) (Alternative to LF1) (For all models except CZH015050yyymm UGa)	Huizhou Jinmei Technology Co., Ltd.	AL0510	130°C	IEC/EN IEC 61558-1, IEC/EN 61558-2- 16	Tested with appliance
(Alternative)	Shenzhen Jingchengyuan Electronics Co., Ltd.	AL0510	130°C	IEC/EN IEC 61558-1, IEC/EN 61558-2- 16	Tested with appliance
(Alternative)	Huizhou Jinmei Technology Co., Ltd.	DR8*10	130°C	IEC/EN IEC 61558-1, IEC/EN 61558-2- 16	Tested with appliance
-Magnet wire of L1	GUANGZHOU WANBAO ENAMELLED WIRE CO LTD	xUEW-130, xPU/130, QA- x/130	130°C	UL 1446	UL
(Alternative)	ZHEJIANG HONGBO TECHNOLOGY CO LTD	xUEW/130, QA- x/130	130°C	UL 1446	UL
(Alternative)	TAI-I ELECTRIC WIRE & CABLE CO LTD	UEW	130°C	UL 1446	UL
(Alternative)	DONGGUAN XINLONG VARNISHED WIRE CO LTD	xUEW	130°C	UL 1446	UL
(Alternative)	HOI LUEN ELECTRICAL MFR CO LTD	xUEW	130°C	UL 1446	UL
(Alternative)	DONG GUAN XIN YOU LIAN COPPER CO LTD	2UEW	130°C	UL 1446	UL
-Heat shrinkable tube of L1	SHENZHEN WOER HEAT- SHRINKABLE MATERIAL CO LTD	RSFR, RSFR- H	Min. 300V, min. 125°C, VW-1 thickness min. 0.2mm	UL 224	UL
(Alternative)	DONG GUAN HUANG FENG INSULATION MATERIAL CO LTD	HFT-2	Min. 300V, min. 125°C, VW-1 thickness min. 0.2mm	UL 224	UL
(Alternative)	SHENZHEN WOLIDA TRADING CO LTD	RSFR-H, RSFR(CB)	Min. 300V, min. 125°C, VW-1 thickness min. 0.2mm	UL 224	UL

IEC 61558-2-16					
Clause	Requirement + Test			Result - Remark	Verdict
(Alternative)	CHANGYUAN ELECTRONICS GROUP CO LTD	CB-HFT*, CB-HFT(XY)*; CYG-MT*	Min. 300V, min. 125°C, VW-1 thickness min. 0.2mm	UL 224	UL
(Alternative)	3M COMPANY ELECTRICAL MARKETS DIV (EMD)	SFTW-A VW1, HFT VW1	Min. 300V, min. 125°C, VW-1 thickness min. 0.2mm	UL 224	UL
Choke (LF1) (Alternative to L1) (For all models except CZH015050yyymm UGa)	Huizhou Jinmei Technology Co., Ltd.	EE8.3	130°C	IEC/EN IEC 61558-1, IEC/EN 61558-2-16	Tested with appliance
(Alternative)	Shenzhen Jingchengyuan Electronics Co., Ltd.	EE8.3	130°C	IEC/EN IEC 61558-1, IEC/EN 61558-2-16	Tested with appliance
-Bobbin of LF1	CHANG CHUN PLASTICS CO LTD	T375J(G5)(G6)	V-0, 150°C, min. 0.51mm thickness, phenolic.	UL 94	UL
(Alternative)	SUMITOMO BAKELITE CO LTD	PM-9820, PM-9630	V-0, 150°C, min. 0.51mm thickness, phenolic.	UL 94	UL
(Alternative)	HITACHI CHEMICAL CO LTD	CP-J-8800	V-0, 150°C, min. 0.51mm thickness, phenolic.	UL 94	UL
-Magnet wire of LF1	GUANGZHOU WANBAO ENAMELLED WIRE CO LTD	xUEW-130, xPU/130, QA-x/130	130°C	UL 1446	UL
(Alternative)	ZHEJIANG HONGBO TECHNOLOGY CO LTD	xUEW/130, QA-x/130	130°C	UL 1446	UL
(Alternative)	TAI-I ELECTRIC WIRE & CABLE CO LTD	UEW	130°C	UL 1446	UL
(Alternative)	DONGGUAN XINLONG VARNISHED WIRE CO LTD	xUEW	130°C	UL 1446	UL
(Alternative)	HOI LUEN ELECTRICAL MFR CO LTD	xUEW	130°C	UL 1446	UL

IEC 61558-2-16					
Clause	Requirement + Test			Result - Remark	Verdict
(Alternative)	DONG GUAN XIN YOU LIAN COPPER CO LTD	2UEW	130°C	UL 1446	UL
-Insulation tape of LF1	JINGJIANG YAHUA PRESSURE SENSITIVE GLUE CO LTD	CT* (c)(g), PZ* (b)	130°C	UL 510A	UL
(Alternative)	CHANG SHU LIANG YI TAPE INDUSTRY CO LTD	LY-XX*	130°C	UL 510A	UL
(Alternative)	3M COMPANY ELECTRICAL MARKETS DIV (EMD)	1350-1 (b), 1350Y-1 (b), 1350F-1 (b)	130°C	UL 510A	UL
Y-capacitor (CY1, CY2) (Optional)	Shaanxi Huaxing Electronic Development Co. Ltd.	CT7Y1	Max. 2200pF, min. 250VAC, 125°C, Y1 type	IEC/EN/UL 60384-14	VDE, UL
(Alternative)	Success Electronics Co., Ltd.	SB	Max. 2200pF, min. 250VAC, 125°C, Y1 type	IEC/EN/UL 60384-14	VDE, UL
(Alternative)	Success Electronics Co., Ltd.	SE	Max. 2200pF, min. 250VAC, 125°C, Y1 type	IEC/EN/UL 60384-14	VDE, UL
(Alternative)	Guangdong South Hongming Electronic Science and Technology Co., Ltd.	F	Max. 2200pF, min. 250VAC, 125°C, Y1 type	IEC/EN/UL 60384-14	VDE, UL
(Alternative)	Shantou High- New Technology Dev. Zone Songtian Enterprise Co., Ltd.	CD-Series	Max. 2200pF, min. 250VAC, 125°C, Y1 type	IEC/EN/UL 60384-14	VDE, UL
(Alternative)	Shenzhen Haotian Electronic Co., Ltd.	HT	Max. 2200pF, min. 250VAC, 125°C, Y1 type	IEC/EN/UL 60384-14	VDE, UL
(Alternative)	Dongguan Easy- gather Electronic Co., Ltd.	DCF	Max. 2200pF, min. 250VAC, 125°C, Y1 type	IEC/EN/UL 60384-14	VDE, UL
(Alternative)	Jyh Chung Electronic Co., Ltd.	JD	Max. 2200pF, min. 250VAC, 125°C, Y1 type	IEC/EN/UL 60384-14	VDE, UL

IEC 61558-2-16					
Clause	Requirement + Test			Result - Remark	Verdict
(Alternative)	Dongguan City Dafu Electronics Co. Ltd.	CT7 Y1 Series	Max. 2200pF, min. 250VAC, 125°C, Y1 type	IEC/EN/UL 60384-14	VDE, UL
(Alternative)	Nanjing Yuyue Electronics Co., Ltd.	CT7	Max. 2200pF, min. 250VAC, 125°C, Y1 type	IEC/EN/UL 60384-14	VDE, UL
(Alternative)	Haohua Electronic Co.,	CT7	Max. 2200pF, min. 250VAC, 125°C, Y1 type	IEC/EN/UL 60384-14	VDE, UL
(Alternative)	Welson Industrial Co., Ltd.	WD	Max. 2200pF, min. 250VAC, 125°C, Y1 type	IEC/EN/UL 60384-14	VDE, UL
(Alternative)	Xiangtai Electronics (Shenzhen) Co., Ltd.	YO-series	Max. 2200pF, min. 250VAC, 125°C, Y1 type	IEC/EN/UL 60384-14	VDE, UL
(Alternative)	Dongguan City Dersonic Electronic Co., Ltd.	CD	Max. 2200pF, min. 250VAC, 125°C, Y1 type	IEC/EN/UL 60384-14	VDE, UL
(Alternative)	Dongguan Cigu Electronic Technology Co., Ltd	CD	Max. 2200pF, min. 250VAC, 125°C, Y1 type	IEC/EN/UL 60384-14	VDE, UL
(Alternative)	Hsuan Tai Electronic Co. Ltd.	CY	Max. 2200pF, min. 250VAC, 125°C, Y1 type	IEC/EN/UL 60384-14	VDE, UL
(Alternative)	Shenzhen Song Te Electronics Co., Ltd.	CT7	Max. 2200pF, min. 250VAC, 125°C, Y1 type	IEC/EN/UL 60384-14	VDE, UL
(Alternative)	Shaanxi Huaxing Electronic Development Co. Ltd.	CT7Y2	Max. 2200pF, min. 250VAC, 125°C, Y2 type	IEC/EN/UL 60384-14	VDE, UL
(Alternative)	Success Electronics Co., Ltd.	SB	Max. 2200pF, min. 250VAC, 125°C, Y2 type	IEC/EN/UL 60384-14	VDE, UL
(Alternative)	Success Electronics Co., Ltd.	SE	Max. 2200pF, min. 250VAC, 125°C, Y2 type	IEC/EN/UL 60384-14	VDE, UL
(Alternative)	Guangdong South Hongming Electronic Science and Technology Co., Ltd.	F	Max. 2200pF, min. 250VAC, 125°C, Y2 type	IEC/EN/UL 60384-14	VDE, UL

IEC 61558-2-16					
Clause	Requirement + Test		Result - Remark		Verdict
(Alternative)	Shantou High-New Technology Dev. Zone Songtian Enterprise Co., Ltd.	CE	Max. 2200pF, min. 250VAC, 125°C, Y2 type	IEC/EN/UL 60384-14	VDE, UL
(Alternative)	Shenzhen Haotian Electronic Co., Ltd.	HTC	Max. 2200pF, min. 250VAC, 125°C, Y2 type	IEC/EN/UL 60384-14	VDE, UL
(Alternative)	Dongguan Easy-gather Electronic Co., Ltd.	DCF	Max. 2200pF, min. 250VAC, 125°C, Y2 type	IEC/EN/UL 60384-14	VDE, UL
(Alternative)	Jyh Chung Electronic Co., Ltd.	JY	Max. 2200pF, min. 250VAC, 125°C, Y2 type	IEC/EN/UL 60384-14	VDE, UL
(Alternative)	Dongguan City Dafu Electronics Co. Ltd.	CT7 Y2 Series	Max. 2200pF, min. 250VAC, 125°C, Y2 type	IEC/EN/UL 60384-14	VDE, UL
(Alternative)	Nanjing Yuyue Electronics Co., Ltd.	CT7	Max. 2200pF, min. 250VAC, 125°C, Y2 type	IEC/EN/UL 60384-14	VDE, UL
(Alternative)	Haohua Electronic Co.,	CT7	Max. 2200pF, min. 250VAC, 125°C, Y2 type	IEC/EN/UL 60384-14	VDE, UL
(Alternative)	Welson Industrial Co., Ltd.	KL	Max. 2200pF, min. 250VAC, 125°C, Y2 type	IEC/EN/UL 60384-14	VDE, UL
(Alternative)	Xiangtai Electronics (Shenzhen) Co., Ltd.	YT	Max. 2200pF, min. 250VAC, 125°C, Y2 type	IEC/EN/UL 60384-14	VDE, UL
(Alternative)	Dongguan City Dersonic Electronic Co., Ltd.	CS	Max. 2200pF, min. 250VAC, 125°C, Y2 type	IEC/EN/UL 60384-14	VDE, UL
(Alternative)	Dongguan Cigu Electronic Technology Co., Ltd	CE	Max. 2200pF, min. 250VAC, 125°C, Y2 type	IEC/EN/UL 60384-14	VDE, UL
(Alternative)	Shenzhen Song Te Electronics Co., Ltd.	CT7-series	Max. 2200pF, min. 250VAC, 125°C, Y2 type	IEC/EN/UL 60384-14	VDE, UL
Y-capacitor (CY3) (Optional)	Shaanxi Huaxing Electronic Development Co. Ltd.	CT7Y1	Max. 2200pF, min. 250VAC, 125°C, Y1 type	IEC/EN/UL 60384-14	VDE, UL

IEC 61558-2-16					
Clause	Requirement + Test			Result - Remark	Verdict
(Alternative)	Success Electronics Co., Ltd.	SB	Max. 2200pF, min. 250VAC, 125°C, Y1 type	IEC/EN/UL 60384-14	VDE, UL
(Alternative)	Success Electronics Co., Ltd.	SE	Max. 2200pF, min. 250VAC, 125°C, Y1 type	IEC/EN/UL 60384-14	VDE, UL
(Alternative)	Guangdong South Hongming Electronic Science and Technology Co., Ltd.	F	Max. 2200pF, min. 250VAC, 125°C, Y1 type	IEC/EN/UL 60384-14	VDE, UL
(Alternative)	Shantou High-New Technology Dev. Zone Songtian Enterprise Co., Ltd.	CD-Series	Max. 2200pF, min. 250VAC, 125°C, Y1 type	IEC/EN/UL 60384-14	VDE, UL
(Alternative)	Shenzhen Haotian Electronic Co., Ltd.	HT	Max. 2200pF, min. 250VAC, 125°C, Y1 type	IEC/EN/UL 60384-14	VDE, UL
(Alternative)	Dongguan Easy-gather Electronic Co., Ltd.	DCF	Max. 2200pF, min. 250VAC, 125°C, Y1 type	IEC/EN/UL 60384-14	VDE, UL
(Alternative)	Jyh Chung Electronic Co., Ltd.	JD	Max. 2200pF, min. 250VAC, 125°C, Y1 type	IEC/EN/UL 60384-14	VDE, UL
(Alternative)	Dongguan City Dafu Electronics Co. Ltd.	CT7 Y1 Series	Max. 2200pF, min. 250VAC, 125°C, Y1 type	IEC/EN/UL 60384-14	VDE, UL
(Alternative)	Nanjing Yuyue Electronics Co., Ltd.	CT7	Max. 2200pF, min. 250VAC, 125°C, Y1 type	IEC/EN/UL 60384-14	VDE, UL
(Alternative)	Haohua Electronic Co.,	CT7	Max. 2200pF, min. 250VAC, 125°C, Y1 type	IEC/EN/UL 60384-14	VDE, UL
(Alternative)	Welson Industrial Co., Ltd.	WD	Max. 2200pF, min. 250VAC, 125°C, Y1 type	IEC/EN/UL 60384-14	VDE, UL
(Alternative)	Xiangtai Electronics (Shenzhen) Co., Ltd.	YO-series	Max. 2200pF, min. 250VAC, 125°C, Y1 type	IEC/EN/UL 60384-14	VDE, UL
(Alternative)	Dongguan City Dersonic Electronic Co., Ltd.	CD	Max. 2200pF, min. 250VAC, 125°C, Y1 type	IEC/EN/UL 60384-14	VDE, UL

IEC 61558-2-16					
Clause	Requirement + Test			Result - Remark	Verdict
(Alternative)	Dongguan Cigu Electronic Technology Co., Ltd	CD	Max. 2200pF, min. 250VAC, 125°C, Y1 type	IEC/EN/UL 60384-14	VDE, UL
(Alternative)	Hsuan Tai Electronic Co. Ltd.	CY	Max. 2200pF, min. 250VAC, 125°C, Y1 type	IEC/EN/UL 60384-14	VDE, UL
(Alternative)	Shenzhen Song Te Electronics Co., Ltd.	CT7	Max. 2200pF, min. 250VAC, 125°C, Y1 type	IEC/EN/UL 60384-14	VDE, UL
Transformer (T1) (For models CZH015050yyymm UGa)		CZH015-05V-A	Class B	IEC/EN IEC 61558-1, IEC/EN 61558-2-16	Tested with appliance
Transformer (T1) (For all models except CZH015050yyymm UGa)		CZH015-05V-Ax (x=0-9 or A-Z or Blank) (For rated output voltage 5.0-7.5VDC models)	Class B	IEC/EN IEC 61558-1, IEC/EN 61558-2-16	Tested with appliance
		CZH015-09V-Ax (x=0-9 or A-Z or Blank) (For rated output voltage 7.6-11.5VDC models)	Class B	IEC/EN IEC 61558-1, IEC/EN 61558-2-16	Tested with appliance
		CZH015-12V-Ax (x=0-9 or A-Z or Blank) (For rated output voltage 11.6-16.5VDC models)	Class B	IEC/EN IEC 61558-1, IEC/EN 61558-2-16	Tested with appliance
		CZH015-20V-Ax (x=0-9 or A-Z or Blank) (For rated output voltage 16.6-23.0VDC models)	Class B	IEC/EN IEC 61558-1, IEC/EN 61558-2-16	Tested with appliance
		CZH015-30V-Ax (x=0-9 or A-Z or Blank) (For rated output voltage 23.1-30.0VDC models)	Class B	IEC/EN IEC 61558-1, IEC/EN 61558-2-16	Tested with appliance

IEC 61558-2-16					
Clause	Requirement + Test		Result - Remark		Verdict
		CZH015-42V-Ax (x=0-9 or A-Z or Blank) (For rated output voltage 30.1-42.0VDC models)	Class B	IEC/EN IEC 61558-1, IEC/EN 61558-2-16	Tested with appliance
-Bobbin	CHANG CHUN PLASTICS CO LTD	T375J(G5)(G6)	V-0, 150°C, min. 0.51mm thickness, phenolic.	UL 94	UL
(Alternative)	SUMITOMO BAKELITE CO LTD	PM-9820, PM-9630	V-0, 150°C, min. 0.51mm thickness, phenolic.	UL 94	UL
(Alternative)	HITACHI CHEMICAL CO LTD	CP-J-8800	V-0, 150°C, min. 0.51mm thickness, phenolic.	UL 94	UL
-Magnet wire (Primary winding)	GUANGZHOU WANBAO ENAMELLED WIRE CO LTD	xUEW-130, xPU/130, QA-x/130	130°C	UL 1446	UL
(Alternative)	ZHEJIANG HONGBO TECHNOLOGY CO LTD	xUEW/130, QA-x/130	130°C	UL 1446	UL
(Alternative)	TAI-I ELECTRIC WIRE & CABLE CO LTD	UEW	130°C	UL 1446	UL
(Alternative)	DONGGUAN XINLONG VARNISHED WIRE CO LTD	xUEW	130°C	UL 1446	UL
(Alternative)	HOI LUEN ELECTRICAL MFR CO LTD	xUEW	130°C	UL 1446	UL
(Alternative)	DONG GUAN XIN YOU LIAN COPPER CO LTD	2UEW	130°C	UL 1446	UL
-Triple insulation wire (Secondary winding)	Furukawa Electric Co., Ltd.	TEX-E	Reinforced insulation, 130°C	IEC/EN 61558-1, IEC/EN 61558-2-16	VDE
(Alternative)	Dah Jin Technology Co., Ltd.	TLW-B	Reinforced insulation, 130°C	IEC/EN 61558-1, IEC/EN 61558-2-16	VDE
(Alternative)	Great Leoflon Industrial Co., Ltd.	TRW(B) Serie(s), TRW(F) Serie(s)	Reinforced insulation, 130°C	IEC/EN 61558-1, IEC/EN 61558-2-16	VDE

IEC 61558-2-16					
Clause	Requirement + Test			Result - Remark	Verdict
-Insulation tape	JINGJIANG YAHUA PRESSURE SENSITIVE GLUE CO LTD	CT* (c)(g), PZ* (b)	130°C	UL 510A	UL
(Alternative)	CHANG SHU LIANG YI TAPE INDUSTRY CO LTD	LY-XX*	130°C	UL 510A	UL
(Alternative)	3M COMPANY ELECTRICAL MARKETS DIV (EMD)	1350-1 (b), 1350Y-1 (b), 1350F-1 (b)	130°C	UL 510A	UL
-Varnish	HITACHI CHEMICAL CO LTD	WP-2952F-2G	130°C	UL 1446	UL
(Alternative)	SUZHOU TAIHU ELECTRIC ADVANCED MATERIAL CO LTD	ET-90(a), T-1168(a), T-4260(a)	130°C	UL 1446	UL
(Alternative)	JOHN C DOLPH CO	AC-43, BC-359	130°C	UL 1446	UL
(Alternative)	ELANTAS ELECTRICAL INSULATION ELANTAS PDG INC	468-2 (d), 468-2FC (d), 468-2-7-xxF (d), 468-2-7FC-xxF (d)	130°C	UL 1446	UL
- Insulation tube	GREAT HOLDING INDUSTRIAL CO LTD	TFL, TFS, TFT	200°C, VW-1	UL 224	UL
Input wire (Except for models CZH015xxxxyyTR WM, CZH015xxxxyyTR WF, CZH015xxxxyyTR WML, CZH015xxxxyyTR WFL) (Optional)	STAB INDUSTRIAL CO LTD	1007, 1015	Min. 24AWG, VW-1, min. 80°C, min. 300V	UL 758	UL
(Alternative)	SHENZHEN RUITENGXIAN G ELECTRONICS CO LTD	1007, 1015	Min. 24AWG, VW-1, min. 80°C, min. 300V	UL 758	UL

IEC 61558-2-16					
Clause	Requirement + Test			Result - Remark	Verdict
(Alternative)	DONGGUAN JIAPENG INDUSTRIAL CO LTD	1007, 1015	Min. 24AWG, VW-1, min. 80°C, min. 300V	UL 758	UL
(Alternative)	DONGGUAN CHANG XIN CABLE TECHNOLOGY CO LTD	1007, 1015	Min. 24AWG, VW-1, min. 80°C, min. 300V	UL 758	UL
(Alternative)	DONGGUAN LICHENG ELECTRONICS CO LTD	1007, 1015	Min. 24AWG, VW-1, min. 80°C, min. 300V	UL 758	UL
(Alternative)	DONGGUAN HONGFUWEI CABLE TECHNOLOGY CO LTD	1007, 1015	Min. 24AWG, VW-1, min. 80°C, min. 300V	UL 758	UL
(Alternative)	SHENZHEN BENDA ELECTRICIAN MATERIAL CO LTD	1007, 1015	Min. 24AWG, VW-1, min. 80°C, min. 300V	UL 758	UL
(Alternative)	HERWELL ELECTRIC WIRE CO LTD	1007, 1015	Min. 24AWG, VW-1, min. 80°C, min. 300V	UL 758	UL
(Alternative)	SHENZHEN WEI FAN ELECTRONIC TECHNOLOGY CO LTD	1007, 1015	Min. 24AWG, VW-1, min. 80°C, min. 300V	UL 758	UL
(Alternative)	SHENZHEN BOSITAI COMPUTER ACCESSORY CO LTD	1007, 1015	Min. 24AWG, VW-1, min. 80°C, min. 300V	UL 758	UL
(Alternative)	SHENZHEN ZHENGERYA TECHNOLOGY CO LTD	1007, 1015	Min. 24AWG, VW-1, min. 80°C, min. 300V	UL 758	UL
(Alternative)	YSC ELECTRONICS (HONG KONG) CO LTD	1007, 1015	Min. 24AWG, VW-1, min. 80°C, min. 300V	UL 758	UL
Output wire #	RUITENGXIAN G ELECTRONICS CO LTD DONGGUAN BRANCH	2464, 2468, 1185	Min. 24AWG, VW-1, min. 80°C, min. 300V	UL 758	UL

IEC 61558-2-16					
Clause	Requirement + Test			Result - Remark	Verdict
(Alternative)	SHENZHEN BOSITAI COMPUTER ACCESSORY CO LTD	2464, 2468, 1185	Min. 24AWG, VW-1, min. 80°C, min. 300V	UL 758	UL
(Alternative)	SHENZHEN ZHENGERYA TECHNOLOGY CO LTD	2464, 2468, 1185	Min. 24AWG, VW-1, min. 80°C, min. 300V	UL 758	UL
(Alternative)	YSC ELECTRONICS (HONG KONG) CO LTD	2464, 2468, 1185	Min. 24AWG, VW-1, min. 80°C, min. 300V	UL 758	UL
Output connector material	SABIC INNOVATIVE PLASTICS US LLC	SE1(F1), EN265(f1)	V-0, 105°C	UL 94, IEC/EN IEC 61558-1, IEC/EN 61558-2-16	UL, Tested with appliance
Potting material (For models CZH015xxxxyyymm WHG, CZH015xxxxyyymm WHLG, CZH015xxxxyyymm WPG, CZH015xxxxyyymm WPLG, CZH015xxxxyyymm WMG, CZH015xxxxyyymm WMLG, CZH015xxxxyyymm WFG, CZH015xxxxyyymm WFLG, CZH015xxxxyyymm WQG, CZH015xxxxyyymm WQLG)	SHENZHEN JADOBLO SCIENCE & TECHNOLOGY CO LTD	JDB805, JDB807, JDB811, JDB832, JDB890	V-0, 105°C	UL 94, IEC/EN IEC 61558-1, IEC/EN 61558-2-16	UL, Tested with appliance
Supplementary information: 1) Provided evidence ensures the agreed level of compliance. See OD-CB2039. 2) License available upon request. #: Output wire less than 20AWG cannot be used unless it is evaluated and allowed by end product standard.					

25	TABLE: Threaded Part Torque Test			N/A
Threaded part identification	Diameter of thread (mm)	Column number (I, II, or III)	Applied torque (Nm)	
--	--	--	--	
Supplementary information:				

IEC 61558-2-16						
Clause	Requirement + Test	Result - Remark				Verdict
26	TABLE: Clearance And Creepage Distance Measurements					P
clearance cl and creepage distance dcr at/of:	Up (V)	U r.m.s. (V)	Required cl (mm)	cl (mm)	required dcr (mm)	dcr (mm)
For models CZH015xxxxyymmWH, CZH015xxxxyymmWP, CZH015xxxxyymmWHG, CZH015xxxxyymmWPG (with PCB Layout type A)						
L and N before F1 (BI)	420	240	1.5	3.2	2.5	3.2
Two terminals of F1 (BI)	420	240	1.5	4.6	2.5	4.6
Two terminals of CY1 (BI)	420	240	1.5	3.2	2.5	3.2
Two terminals of CY2 (SI)	420	240	1.5	2.8	2.5	2.8
CY1 Pri. trace and CY2 sec. trace (RI)	420	240	3.0	6.0	5.0	6.0
Pri. trace and sec. trace under T1 (RI)	610	259	3.0	6.2	5.3	6.2
Between T1 primary winding and T1 secondary pin (RI)	610	259	3.0	6.6	5.3	6.6
Between T1 core and T1 secondary pin (RI)	610	259	3.0	10.0	5.3	10.0
Between T1 core and secondary components output wire, LF2, L2, C9, C10, D3, CY2 secondary pin (RI)	610	259	3.0	6.5	5.3	6.5
Between T1 core to the middle pin of CY1 & CY2 (BI)	610	259	1.5	3.4	2.7	3.4
Pri. parts and accessible enclosure surface (RI)	420	240	3.0	7.0	5.0	7.0
For models CZH015xxxxyymmWH, CZH015xxxxyymmWP, CZH015xxxxyymmWHG, CZH015xxxxyymmWPG, CZH015xxxxyymmWHL, CZH015xxxxyymmWPL, CZH015xxxxyymmWHLG, CZH015xxxxyymmWPLG (with PCB Layout type B)						
L and N before F1 (BI)	420	240	1.5	3.2	2.5	3.2
Two terminals of F1 (BI)	420	240	1.5	4.6	2.5	4.6
Two terminals of CY1 (BI)	420	240	1.5	3.2	2.5	3.2
Two terminals of CY2 (SI)	420	240	1.5	2.8	2.5	2.8
CY1 Pri. trace and CY2 sec. trace (RI)	420	240	3.0	6.0	5.0	6.0
Pri. trace and sec. trace under T1 (RI)	610	259	3.0	6.2	5.3	6.2
Between T1 primary winding and T1 secondary pin (RI)	610	259	3.0	6.6	5.3	6.6
Between T1 core and T1 secondary pin (RI)	610	259	3.0	10.0	5.3	10.0
Between T1 core and secondary components output wire, LF2, C9, C10, CY2 secondary pin (RI)	610	259	3.0	6.5	5.3	6.5
Between T1 core to the middle pin of CY1 & CY2 (BI)	610	259	1.5	3.4	2.7	3.4

IEC 61558-2-16						
Clause	Requirement + Test			Result - Remark		Verdict
Pri. parts and accessible enclosure surface (RI)	420	240	3.0	7.0	5.0	7.0
For models CZH015xxxxyymmWM, CZH015xxxxyymmWF, CZH015xxxxyymmWWMG, CZH015xxxxyymmWFG, CZH015xxxxyymmWML, CZH015xxxxyymmWFL, CZH015xxxxyymmWMLG, CZH015xxxxyymmWFLG, CZH015xxxxyyTRWML, CZH015xxxxyyTRWFL, CZH015xxxxyyTRWM, CZH015xxxxyyTRWF (with PCB Layout type C)						
L and N before F1 (BI)	420	240	1.5	3.2	2.5	3.2
Two terminals of F1 (BI)	420	240	1.5	4.6	2.5	4.6
Two terminals of CY1 (BI)	420	240	1.5	3.2	2.5	3.2
Two terminals of CY2 (SI)	420	240	1.5	2.8	2.5	2.8
CY1 Pri. trace and CY2 sec. trace (RI)	420	240	3.0	6.0	5.0	6.0
Pri. trace and sec. trace under T1 (RI)	610	259	3.0	6.2	5.3	6.2
Between T1 primary winding and T1 secondary pin (RI)	610	259	3.0	6.6	5.3	6.6
Between T1 core and T1 secondary pin (RI)	610	259	3.0	10.0	5.3	10.0
Between T1 core and secondary components output wire, LF2, C9, C10, CY2 secondary pin (RI)	610	259	3.0	6.5	5.3	6.5
Between T1 core to the middle pin of CY1 & CY2 (BI)	610	259	1.5	3.4	2.7	3.4
Pri. parts and accessible enclosure surface (RI)	420	240	3.0	7.0	5.0	7.0
For models CZH015xxxxyymmWM, CZH015xxxxyymmWF, CZH015xxxxyymmWWMG, CZH015xxxxyymmWFG, CZH015xxxxyymmWML, CZH015xxxxyymmWFL, CZH015xxxxyymmWMLG, CZH015xxxxyymmWFLG, CZH015xxxxyyTRWML, CZH015xxxxyyTRWFL, CZH015xxxxyyTRWM, CZH015xxxxyyTRWF (with PCB Layout type C)						
L and N before F1 (BI)	420	240	1.5	3.2	2.5	3.2
Two terminals of F1 (BI)	420	240	1.5	4.5	2.5	4.5
Two terminals of CY1 (BI)	420	240	1.5	2.6	2.5	2.6
Two terminals of CY2 (SI)	420	240	1.5	2.6	2.5	2.6
CY1 Pri. trace and CY2 sec. trace (RI)	420	240	3.0	5.2	5.0	5.2
Pri. trace and sec. trace under T1 (RI)	610	259	3.0	6.7	5.3	6.7
Between T1 primary winding and T1 secondary pin (RI)	610	259	3.0	6.6	5.3	6.6
Between T1 core and T1 secondary pin (RI)	610	259	3.0	10.0	5.3	10.0
Between T1 core and secondary components output wire, LF2, C9, C10, CY2 secondary pin (RI)	610	259	3.0	5.8	5.3	5.8

IEC 61558-2-16						
Clause	Requirement + Test			Result - Remark		Verdict
Between T1 core to the middle pin of CY1 & CY2 (BI)	610	259	1.5	4.0	2.7	4.0
Pri. parts and accessible enclosure surface (RI)	420	240	3.0	7.2	5.0	7.2
Live parts with detachable plug and accessible enclosure surface (RI) (For models CZH015xxxxyyTRWML, CZH015xxxxyyTRWFL, CZH015xxxxyyTRWM, CZH015xxxxyyTRWF)	420	240	3.0	5.9	5.0	5.9
For models CZH015050yyymmUM (with PCB Layout type D)						
L and N before (F1) (BI)	420	240	1.5	3.2	2.5	3.2
Two terminals of F1 (BI)	420	240	1.5	4.5	2.5	4.5
Two terminals of CY1 (BI)	420	240	1.5	3.0	2.5	3.0
Two terminals of CY2 (SI)	420	240	1.5	2.6	2.5	2.6
CY1 Pri. trace and CY2 sec. trace (RI)	420	240	3.0	5.6	5.0	5.6
Pri. trace and sec. trace under T1 (RI)	610	259	3.0	7.8	5.3	7.8
Between T1 primary winding and T1 secondary pin (RI)	610	259	3.0	6.6	5.3	6.6
Between T1 core and T1 secondary pin (RI)	610	259	3.0	10.0	5.3	10.0
Between T1 core and secondary components USB, C9, C10, CY2 secondary pin (RI)	610	259	3.0	5.8	5.3	5.8
Between T1 core to the middle pin of CY1 & CY2 (BI)	610	259	1.5	4.0	2.3	4.0
Pri. parts and accessible enclosure surface (RI)	420	240	3.0	7.2	5.0	7.2
For models CZH015xxxxyyEUWAa (with PCB Layout type E)						
L and N before (F1) (BI)	420	240	1.5	4.7	2.5	4.7
Two terminals of F1 (BI)	420	240	1.5	3.8	2.5	3.8
Two terminals of CY1 (BI)	420	240	1.5	3.2	2.5	3.2
Two terminals of CY2 (SI)	420	240	1.5	2.7	2.5	2.7
Pri. trace and sec. trace under T1 (RI)	610	259	3.0	6.8	5.3	6.8
Between T1 primary winding and T1 secondary pin (RI)	610	259	3.0	6.6	5.3	6.6
Between T1 core and T1 secondary pin (RI)	610	259	3.0	10.0	5.3	10.0

IEC 61558-2-16						
Clause	Requirement + Test			Result - Remark		Verdict
Between T1 core and secondary components C9, C10, CY2 secondary pin (RI)	610	259	3.0	5.4	5.3	5.4
Between T1 core to the middle pin of CY1 & CY2 (BI)	610	259	1.5	3.5	2.7	3.5
Pri. parts and accessible enclosure surface (RI)	420	240	3.0	6.1	5.0	6.1
For models CZH015xxxxyymmWQ, CZH015xxxxyymmWQG, CZH015xxxxyymmWQL, CZH015xxxxyymmWQLG, CZH015xxxxyyTRWQ, CZH015xxxxyyTRWQL (with PCB Layout type A)						
L and N before (F1) (BI)	420	240	1.5	3.2	2.5	3.2
Two terminals of F1 (BI)	420	240	1.5	4.6	2.5	4.6
Two terminals of CY1 (BI)	420	240	1.5	3.2	2.5	3.2
Two terminals of CY2 (SI)	420	240	1.5	2.8	2.5	2.8
CY1 Pri. trace and CY2 sec. trace (RI)	420	240	3.0	6.0	5.0	6.0
Pri. trace and sec. trace under T1 (RI)	610	259	3.0	6.2	5.3	6.2
Between T1 primary winding and T1 secondary pin (RI)	610	259	3.0	6.6	5.3	6.6
Between T1 core and T1 secondary pin (RI)	610	259	3.0	10.0	5.3	10.0
Between T1 core and secondary components output wire, LF2, L2, C9, C10, D3, CY2 secondary pin (RI)	610	259	3.0	6.5	5.3	6.5
Between T1 core to the middle pin of CY1 & CY2 (BI)	610	259	1.5	3.4	2.7	3.4
Pri. parts of detachable plug to accessible enclosure surface (RI)	420	240	3.0	5.6	5.0	5.6
Pri. parts and accessible enclosure surface (RI)	420	240	3.0	5.3	5.0	5.3
For models CZH015050yyymmUGa (with PCB Layout type F)						
L and N before (F1) (BI)	420	240	1.5	4.0	2.5	4.0
Two terminals of F1 (BI)	420	240	1.5	3.7	2.5	3.7
Two terminals of CY1 (BI)	420	240	1.5	3.1	2.5	3.1
Two terminals of CY2 (SI)	420	240	1.5	2.8	2.5	2.8
CY1 Pri. trace and CY2 sec. trace (RI)	420	240	3.0	5.9	5.0	5.9
Pri. trace and sec. trace under T1 (RI)	610	259	3.0	5.4	5.3	5.4
Between T1 primary winding and T1 secondary pin (RI)	610	259	3.0	6.6	5.3	6.6
Between T1 core and T1 secondary pin (RI)	610	259	3.0	10.0	5.3	10.0

IEC 61558-2-16						
Clause	Requirement + Test			Result - Remark		Verdict
Between T1 core and secondary components USB, C9, C10, CY2 secondary pin (RI)	610	259	3.0	7.3	5.3	7.3
Pri. component EC2 to secondary components USB (RI)	420	240	3.0	5.4	5.0	5.4
Pri. parts and accessible enclosure surface (RI)	420	240	3.0	5.5	5.0	5.5
Supplementary information: 1. The core of T1 is considered as primary live part. 2. If no specified, the worst conditions were recorded. 3. FI: Functional insulation; BI: Basic insulation; SI: Supplementary insulation; RI: Reinforced insulation.						

26	TABLE: Distance Through Insulation Measurements				P
Distance through insulation di at/of:	U r.m.s. (V)	Test voltage (V)	Required di (mm)	di (mm)	
Enclosure (RI)	259	2870	0.87	Min. 2.0	
Insulation sheet between primary and secondary circuit (For models CZH015050yyymmUGa) (RI)	259	2870	0.87	Min. 0.9	
Supplementary information: RI: Reinforced insulation.					

26.2 TEST A	TABLE: CREEPAGE DISTANCES AND CLEARANCES AND DISTANCES THROUGH INSULATION					N/A
	Test with three special prepared specimens with uninsulated wires, without potting or impregnation					
cycles with 2 x working voltage between pri / sec	68 h at the temperature acc. Cl. 14 (min. 85 °C)	1 hour 25 °C	2 hour 0 °C	1 hour 25 °C		
1.						
2.						
3.						
4.						
5.						
6.						
7.						
8.						
9.						
10.						

26.2 TEST B	TABLE: CREEPAGE DISTANCES AND CLEARANCES AND DISTANCES THROUGH INSULATION					N/A
	Test with three specially prepared specimens with potted – P1 values are required					

IEC 61558-2-16						
Clause	Requirement + Test				Result - Remark	Verdict
	cycles with 2 x working voltage between pri / sec	68 h at the temperature acc. Cl. 14 (min. 85 °C)	1 hour 25 °C	2 hour 0 °C	1 hour 25 °C	
1.						
2.						
3.						
4.						
5.						
6.						
7.						
8.						
9.						
10.						

26.2 TEST C	TABLE: CREEPAGE DISTANCES AND CLEARANCES AND DISTANCES THROUGH INSULATION					N/A
	Test with three specially prepared specimens with potting (only dti is required)					
	cycles with 2 x working voltage between pri / sec	68 h at the temperature acc. Cl. 14 (min. 85 °C)	1 hour 25 °C	2 hour 0 °C	1 hour 25 °C	
1.						
2.						
3.						
4.						
5.						
6.						
7.						
8.						
9.						
10.						

26.107 61558-2- 16/A1	TABLE: CREEPAGE DISTANCES AND CLEARANCES AND DISTANCES THROUGH INSULATION					N/A
	Test for transformers, use FIW-wire					
	cycles with 2 x working voltage between pri / sec	68 h at the temperature acc. Cl. 14 (min. 85 °C)	1 hour 25 °C	2 hour 0 °C	1 hour 25 °C	
1.						

IEC 61558-2-16					
Clause	Requirement + Test			Result - Remark	Verdict
2.					
3.					
4.					
5.					
6.					
7.					
8.					
9.					
10.					

27.2	TABLE: Ball Pressure Test of Thermoplastics				P
Allowed impression diameter (mm)				≤ 2 mm	—
Object/ Part No./ Material	Manufacturer/ trademark	Test temperature (°C)		Impression diameter (mm)	
Plug holder & Enclosure/ 940(f1)(gg*)	SABIC INNOVATIVE PLASTICS US L L C	125		1.2	
Bobbin of T1 & LF1/ T375J(G5)(G6)	CHANG CHUN PLASTICS CO LTD	125		1.0	
Bobbin of T1 & LF1/ PM-9630	SUMITOMO BAKELITE CO LTD	125		0.9	
Bobbin of T1 & LF1/ PM-9820	SUMITOMO BAKELITE CO LTD	125		1.1	
Bobbin of T1 & LF1/ CP-J-8800	HITACHI CHEMICAL CO LTD	125		0.8	
Supplementary information: --					

27.4	TABLE: Resistance to heat and fire - Glow wire tests									P
Object/ Part No./ Material	Manufacturer / trademark	Glow wire test (GWT); (°C)								Verdict
		550		650		750		850		
		t _E	t _A	t _E	t _A	t _E	t _A	t _E	t _A	
Plug holder/ 940(f1)(gg*)	See appended table 20	--	--	None	X	None	X	None	X	Pass
Enclosure/ 940(f1)(gg*)	See appended table 20	None	X	None	X	None	X	None	X	Pass
Bobbin of T1 & LF1/ T375J(G5)(G6)	See appended table 20	--	--	--	--	None	X	None	X	Pass
Bobbin of T1 & LF1/ PM-9630	See appended table 20	--	--	--	--	None	X	None	X	Pass

IEC 61558-2-16										
Clause	Requirement + Test					Result - Remark				Verdict
Bobbin of T1 & LF1/ PM-9820	See appended table 20	--	--	--	--	None	X	None	X	Pass
Bobbin of T1 & LF1/ CP-J-8800	See appended table 20	--	--	--	--	None	X	None	X	Pass
Insulation sheet under PCB / Mylar A	See appended table 20	None	X	--	--	--	--	--	--	Pass
Insulating sheet under PCB / AP	See appended table 20	None	X	--	--	--	--	--	--	Pass
Insulating sheet under PCB / EL121	See appended table 20	None	X	--	--	--	--	--	--	Pass
Insulating sheet under PCB / MO21	See appended table 20	None	X	--	--	--	--	--	--	Pass
Insulating sheet under PCB / DF6025	See appended table 20	None	X	--	--	--	--	--	--	Pass
Insulation sheet between primary and secondary circuit (For models CZH015050y yymmUGa) / DFR116ECO A	See appended table 20	None	X	--	--	--	--	--	--	Pass
Insulation sheet between primary and secondary circuit (For models CZH015050y yymmUGa) / DFR116ECO B	See appended table 20	None	X	--	--	--	--	--	--	Pass

IEC 61558-2-16										
Clause	Requirement + Test					Result - Remark				Verdict
Insulation sheet between primary and secondary circuit (For models CZH015050y yymmUGa) / DFR116ECO C	See appended table 20	None	X	--	--	--	--	--	--	Pass
Output connector material / SE1(F1)	See appended table 20	--	--	--	--	None	X	None	X	Pass
Output connector material / EN265(f1)	See appended table 20	--	--	--	--	None	X	None	X	Pass
Heat shrinkable tube / RSFR	See appended table 20	None	X	--	--	--	--	--	--	Pass
Heat shrinkable tube / RSFR-H	See appended table 20	None	X	--	--	--	--	--	--	Pass
Heat shrinkable tube / HFT-2	See appended table 20	None	X	--	--	--	--	--	--	Pass
Heat shrinkable tube / RSFR-H	See appended table 20	None	X	--	--	--	--	--	--	Pass
Heat shrinkable tube / RSFR(CB)	See appended table 20	None	X	--	--	--	--	--	--	Pass
Heat shrinkable tube / CB-HFT*	See appended table 20	None	X	--	--	--	--	--	--	Pass
Heat shrinkable tube / CB-HFT(XY)*	See appended table 20	None	X	--	--	--	--	--	--	Pass
Heat shrinkable tube / CYG-MT*	See appended table 20	None	X	--	--	--	--	--	--	Pass

IEC 61558-2-16										
Clause	Requirement + Test						Result - Remark			Verdict
Heat shrinkable tube / SFTW-A VW1	See appended table 20	None	X	--	--	--	--	--	--	Pass
Heat shrinkable tube / HFT VW1	See appended table 20	None	X	--	--	--	--	--	--	Pass
Ignition of the specified layer placed underneath the test specimen (Yes/No) :										No
Supplementary information: 550 °C GWT not relevant (or applicable) to parts of material classified at least HB40 or if relevant HBF The GWIT pre-selection option, the 850 °C GWF1 pre-selection option, and the 850 °C GWT are not relevant (or applicable) for attended appliances. X means no flame for the test and the time of ti is 0 second.										

Annex H	TABLE: Electronic circuit						P
	Ambient temperature (°C)					25.0°C, if no specified	—
	Power source for EUT: Manufacturer, model/type, output rating					See page 2	—
Component No.	Fault	Supply voltage (V)	Test time	Fuse #	Fuse current (A)	Observation	
Model: CZH015420044EUWH (PCB type A, tested with F1: T2A, 250VAC)							
BD1 pin 1-2 #	SC	240	<1 s	F1	0.158→0	F1 opened immediately, BD1 damaged, no hazard.	
C1 #	SC	240	<1 s	F1	0.158→0	F1 opened immediately, BD1 damaged, no hazard.	
C2 #	SC	240	<1 s	F1	0.158→0	F1 opened immediately, BD1 damaged, no hazard.	
U1 pin 1-4	SC	240	10 min	F1	0.158→0.01	Unit shut down immediately, no damage, no hazard.	
U1 pin 1-7,8	SC	240	10 min	F1	0.158→0.01	Unit shut down immediately, no damage, no hazard.	
U1 pin 5,6-4 #	SC	240	<1 s	F1	0.158→0	F1 opened immediately, BD1, U1 damaged, no hazard.	
U1 pin 5,6-7,8 #	SC	240	<1 s	F1	0.158→0	F1 opened immediately, BD1, U1 damaged, no hazard.	
U1 pin 1-5,6 #	SC	240	<1 s	F1	0.158→0	F1 opened immediately, BD1, U1 damaged, no hazard.	
R10 #	SC	240	<1 s	F1	0.158→0	F1 opened immediately, BD1, U1 damaged, no hazard.	
T1 pin 1-2	SC	240	10 min	F1	0.158→0.01	Unit shut down immediately, no damage, no hazard.	
T1 pin 4-5	SC	240	10 min	F1	0.158→0.01	Unit shut down immediately, no damage, no hazard.	

IEC 61558-2-16						
Clause	Requirement + Test				Result - Remark	Verdict
T1 pin 6-7	SC	240	10 min	F1	0.158→ 0.01	Unit shut down immediately, no damage, no hazard.
D3	SC	240	10 min	F1	0.158→ 0.01	Unit shut down immediately, no damage, no hazard.
C10	SC	240	10 min	F1	0.158→ 0.01	Unit shut down immediately, no damage, no hazard.
Output	SC	240	10 min	F1	0.158→ 0.01	Unit shut down immediately, no damage, no hazard.
Model: CZH015420044EUWH (PCB type A, tested with F1: 1ohm, 2W)						
BD1 pin 1-2 #	SC	240	<1s	F1	0.158→ 0	F1 opened immediately, BD1 damaged, no hazard. Repeat 9 times, total 10 times, same test result came out.
C1 #	SC	240	<1s	F1	0.158→ 0	F1 opened immediately, BD1 damaged, no hazard. Repeat 9 times, total 10 times, same test result came out.
C2 #	SC	240	<1s	F1	0.158→ 0	F1 opened immediately, BD1 damaged, no hazard. Repeat 9 times, total 10 times, same test result came out.
U1 pin 5,6-4 #	SC	240	<1s	F1	0.158→ 0	F1 opened immediately, BD1, U1 damaged, no hazard. Repeat 9 times, total 10 times, same test result came out.
U1 pin 5,6-7,8 #	SC	240	<1s	F1	0.158→ 0	F1 opened immediately, BD1, U1 damaged, no hazard. Repeat 9 times, total 10 times, same test result came out.
U1 pin 1-5,6 #	SC	240	<1s	F1	0.158→ 0	F1 opened immediately, BD1, U1 damaged, no hazard. Repeat 9 times, total 10 times, same test result came out.
U1 pin 1-5,6 #	SC	240	<1s	F1	0.158→ 0	F1 opened immediately, BD1, U1 damaged, no hazard. Repeat 9 times, total 10 times, same test result came out.
R10 #	SC	240	<1s	F1	0.158→ 0	F1 opened immediately, BD1, U1 damaged, no hazard. Repeat 9 times, total 10 times, same test result came out.
Model: CZH015420044EUWHL (PCB type B, tested with F1: T2A, 250VAC)						
BD1 pin 1-2 #	SC	240	<1 s	F1	0.150→ 0	F1 opened immediately, BD1 damaged, no hazard.
C1 #	SC	240	<1 s	F1	0.150→ 0	F1 opened immediately, BD1 damaged, no hazard.
C2 #	SC	240	<1 s	F1	0.150→ 0	F1 opened immediately, BD1 damaged, no hazard.

IEC 61558-2-16						
Clause	Requirement + Test				Result - Remark	Verdict
U1 pin 1-4	SC	240	10 min	F1	0.150→ 0.01	Unit shut down immediately, no damage, no hazard.
U1 pin 1-7,8	SC	240	10 min	F1	0.150→ 0.01	Unit shut down immediately, no damage, no hazard.
U1 pin 5,6-4 #	SC	240	<1 s	F1	0.150→ 0	F1 opened immediately, BD1, U1 damaged, no hazard.
U1 pin 5,6-7,8 #	SC	240	<1 s	F1	0.150→ 0	F1 opened immediately, BD1, U1 damaged, no hazard.
U1 pin 1-5,6 #	SC	240	<1 s	F1	0.150→ 0	F1 opened immediately, BD1, U1 damaged, no hazard.
R10 #	SC	240	<1 s	F1	0.150→ 0	F1 opened immediately, BD1, U1 damaged, no hazard.
T1 pin 1-2	SC	240	10 min	F1	0.150→ 0.01	Unit shut down immediately, no damage, no hazard.
T1 pin 4-5	SC	240	10 min	F1	0.150→ 0.01	Unit shut down immediately, no damage, no hazard.
T1 pin 6-7	SC	240	10 min	F1	0.150→ 0.01	Unit shut down immediately, no damage, no hazard.
D3A	SC	240	10 min	F1	0.150→ 0.01	Unit shut down immediately, no damage, no hazard.
C10	SC	240	10 min	F1	0.150→ 0.01	Unit shut down immediately, no damage, no hazard.
Output	SC	240	10 min	F1	0.150→ 0.01	Unit shut down immediately, no damage, no hazard.
Model: CZH015420044EUWHL (PCB type B, tested with F1: 1ohm, 2W)						
BD1 pin 1-2 #	SC	240	<1s	F1	0.150→ 0	F1 opened immediately, BD1 damaged, no hazard. Repeat 9 times, total 10 times, same test result came out.
C1 #	SC	240	<1s	F1	0.150→ 0	F1 opened immediately, BD1 damaged, no hazard. Repeat 9 times, total 10 times, same test result came out.
C2 #	SC	240	<1s	F1	0.150→ 0	F1 opened immediately, BD1 damaged, no hazard. Repeat 9 times, total 10 times, same test result came out.
U1 pin 5,6-4 #	SC	240	<1s	F1	0.150→ 0	F1 opened immediately, BD1, U1 damaged, no hazard. Repeat 9 times, total 10 times, same test result came out.
U1 pin 5,6-7,8 #	SC	240	<1s	F1	0.150→ 0	F1 opened immediately, BD1, U1 damaged, no hazard. Repeat 9 times, total 10 times, same test result came out.

IEC 61558-2-16						
Clause	Requirement + Test				Result - Remark	Verdict
U1 pin 1-5,6 #	SC	240	<1s	F1	0.150→0	F1 opened immediately, BD1, U1 damaged, no hazard. Repeat 9 times, total 10 times, same test result came out.
U1 pin 1-5,6 #	SC	240	<1s	F1	0.150→0	F1 opened immediately, BD1, U1 damaged, no hazard. Repeat 9 times, total 10 times, same test result came out.
R10 #	SC	240	<1s	F1	0.150→0	F1 opened immediately, BD1, U1 damaged, no hazard. Repeat 9 times, total 10 times, same test result came out.
Model: CZH015050250EUUM (PCB type C, tested with F1: T2A, 250VAC)						
BD1 pin 1-2 #	SC	240	<1 s	F1	0.120→0	F1 opened immediately, BD1 damaged, no hazard.
C1 #	SC	240	<1 s	F1	0.120→0	F1 opened immediately, BD1 damaged, no hazard.
C2 #	SC	240	<1 s	F1	0.120→0	F1 opened immediately, BD1 damaged, no hazard.
U1 pin 1-4	SC	240	10 min	F1	0.120→0.01	Unit shut down immediately, no damage, no hazard.
U1 pin 1-7,8	SC	240	10 min	F1	0.120→0.01	Unit shut down immediately, no damage, no hazard.
U1 pin 5,6-4 #	SC	240	<1 s	F1	0.120→0	F1 opened immediately, BD1, U1 damaged, no hazard.
U1 pin 5,6-7,8 #	SC	240	<1 s	F1	0.120→0	F1 opened immediately, BD1, U1 damaged, no hazard.
U1 pin 1-5,6 #	SC	240	<1 s	F1	0.120→0	F1 opened immediately, BD1, U1 damaged, no hazard.
R10 #	SC	240	<1 s	F1	0.120→0	F1 opened immediately, BD1, U1 damaged, no hazard.
T1 pin 1-2	SC	240	10 min	F1	0.120→0.01	Unit shut down immediately, no damage, no hazard.
T1 pin 4-5	SC	240	10 min	F1	0.120→0.01	Unit shut down immediately, no damage, no hazard.
T1 pin 6-7	SC	240	10 min	F1	0.120→0.01	Unit shut down immediately, no damage, no hazard.
D3	SC	240	10 min	F1	0.120→0.01	Unit shut down immediately, no damage, no hazard.
C10	SC	240	10 min	F1	0.120→0.01	Unit shut down immediately, no damage, no hazard.
Output	SC	240	10 min	F1	0.120→0.01	Unit shut down immediately, no damage, no hazard.
Model: CZH015050250EUUM (PCB type C, tested with F1: 1ohm, 2W)						
BD1 pin 1-2 #	SC	240	<1s	F1	0.120→0	F1 opened immediately, BD1 damaged, no hazard. Repeat 9 times, total 10 times, same test result came out.

IEC 61558-2-16							
Clause	Requirement + Test				Result - Remark		Verdict
C1 #	SC	240	<1s	F1	0.120→0	F1 opened immediately, BD1 damaged, no hazard. Repeat 9 times, total 10 times, same test result came out.	
C2 #	SC	240	<1s	F1	0.120→0	F1 opened immediately, BD1 damaged, no hazard. Repeat 9 times, total 10 times, same test result came out.	
U1 pin 5,6-4 #	SC	240	<1s	F1	0.120→0	F1 opened immediately, BD1, U1 damaged, no hazard. Repeat 9 times, total 10 times, same test result came out.	
U1 pin 5,6-7,8 #	SC	240	<1s	F1	0.120→0	F1 opened immediately, BD1, U1 damaged, no hazard. Repeat 9 times, total 10 times, same test result came out.	
U1 pin 1-5,6 #	SC	240	<1s	F1	0.120→0	F1 opened immediately, BD1, U1 damaged, no hazard. Repeat 9 times, total 10 times, same test result came out.	
U1 pin 1-5,6 #	SC	240	<1s	F1	0.120→0	F1 opened immediately, BD1, U1 damaged, no hazard. Repeat 9 times, total 10 times, same test result came out.	
R10 #	SC	240	<1s	F1	0.120→0	F1 opened immediately, BD1, U1 damaged, no hazard. Repeat 9 times, total 10 times, same test result came out.	
Model: CZH015420044EUWF (PCB type D, tested with F1: T2A, 250VAC)							
BD1 pin 1-2 #	SC	240	<1 s	F1	0.156→0	F1 opened immediately, BD1 damaged, no hazard.	
C1 #	SC	240	<1 s	F1	0.156→0	F1 opened immediately, BD1 damaged, no hazard.	
C2 #	SC	240	<1 s	F1	0.156→0	F1 opened immediately, BD1 damaged, no hazard.	
U1 pin 1-4	SC	240	10 min	F1	0.156→ 0.01	Unit shut down immediately, no damage, no hazard.	
U1 pin 1-7,8	SC	240	10 min	F1	0.156→ 0.01	Unit shut down immediately, no damage, no hazard.	
U1 pin 5,6-4 #	SC	240	<1 s	F1	0.156→0	F1 opened immediately, BD1, U1 damaged, no hazard.	
U1 pin 5,6-7,8 #	SC	240	<1 s	F1	0.156→0	F1 opened immediately, BD1, U1 damaged, no hazard.	
U1 pin 1-5,6 #	SC	240	<1 s	F1	0.156→0	F1 opened immediately, BD1, U1 damaged, no hazard.	
R10 #	SC	240	<1 s	F1	0.156→0	F1 opened immediately, BD1, U1 damaged, no hazard.	
T1 pin 1-2	SC	240	10 min	F1	0.156→ 0.01	Unit shut down immediately, no damage, no hazard.	

IEC 61558-2-16						
Clause	Requirement + Test				Result - Remark	Verdict
T1 pin 4-5	SC	240	10 min	F1	0.156→ 0.01	Unit shut down immediately, no damage, no hazard.
T1 pin 6-7	SC	240	10 min	F1	0.156→ 0.01	Unit shut down immediately, no damage, no hazard.
D3	SC	240	10 min	F1	0.156→ 0.01	Unit shut down immediately, no damage, no hazard.
C10	SC	240	10 min	F1	0.156→ 0.01	Unit shut down immediately, no damage, no hazard.
Output	SC	240	10 min	F1	0.156→ 0.01	Unit shut down immediately, no damage, no hazard.
Model: CZH015420044EUWF (PCB type D, tested with F1: 1ohm, 2W)						
BD1 pin 1-2 #	SC	240	<1s	F1	0.156→ 0	F1 opened immediately, BD1 damaged, no hazard. Repeat 9 times, total 10 times, same test result came out.
C1 #	SC	240	<1s	F1	0.156→ 0	F1 opened immediately, BD1 damaged, no hazard. Repeat 9 times, total 10 times, same test result came out.
C2 #	SC	240	<1s	F1	0.156→ 0	F1 opened immediately, BD1 damaged, no hazard. Repeat 9 times, total 10 times, same test result came out.
U1 pin 5,6-4 #	SC	240	<1s	F1	0.156→ 0	F1 opened immediately, BD1, U1 damaged, no hazard. Repeat 9 times, total 10 times, same test result came out.
U1 pin 5,6-7,8 #	SC	240	<1s	F1	0.156→ 0	F1 opened immediately, BD1, U1 damaged, no hazard. Repeat 9 times, total 10 times, same test result came out.
U1 pin 1-5,6 #	SC	240	<1s	F1	0.156→ 0	F1 opened immediately, BD1, U1 damaged, no hazard. Repeat 9 times, total 10 times, same test result came out.
U1 pin 1-5,6 #	SC	240	<1s	F1	0.156→ 0	F1 opened immediately, BD1, U1 damaged, no hazard. Repeat 9 times, total 10 times, same test result came out.
R10 #	SC	240	<1s	F1	0.156→ 0	F1 opened immediately, BD1, U1 damaged, no hazard. Repeat 9 times, total 10 times, same test result came out.
Model: CZH015420044EUWA (PCB type E, tested with F1: T2A, 250VAC)						
BD1 pin 1-2 #	SC	240	<1 s	F1	0.149→ 0	F1 opened immediately, BD1 damaged, no hazard.
C1 #	SC	240	<1 s	F1	0.149→ 0	F1 opened immediately, BD1 damaged, no hazard.

IEC 61558-2-16						
Clause	Requirement + Test				Result - Remark	Verdict
C2 #	SC	240	<1 s	F1	0.149→0	F1 opened immediately, BD1 damaged, no hazard.
U1 pin 1-4	SC	240	10 min	F1	0.149→0.01	Unit shut down immediately, no damage, no hazard.
U1 pin 1-7,8	SC	240	10 min	F1	0.149→0.01	Unit shut down immediately, no damage, no hazard.
U1 pin 5,6-4 #	SC	240	<1 s	F1	0.149→0	F1 opened immediately, BD1, U1 damaged, no hazard.
U1 pin 5,6-7,8 #	SC	240	<1 s	F1	0.149→0	F1 opened immediately, BD1, U1 damaged, no hazard.
U1 pin 1-5,6 #	SC	240	<1 s	F1	0.149→0	F1 opened immediately, BD1, U1 damaged, no hazard.
R10 #	SC	240	<1 s	F1	0.149→0	F1 opened immediately, BD1, U1 damaged, no hazard.
T1 pin 1-2	SC	240	10 min	F1	0.149→0.01	Unit shut down immediately, no damage, no hazard.
T1 pin 4-5	SC	240	10 min	F1	0.149→0.01	Unit shut down immediately, no damage, no hazard.
T1 pin 6-7	SC	240	10 min	F1	0.149→0.01	Unit shut down immediately, no damage, no hazard.
D3	SC	240	10 min	F1	0.149→0.01	Unit shut down immediately, no damage, no hazard.
C10	SC	240	10 min	F1	0.149→0.01	Unit shut down immediately, no damage, no hazard.
Output	SC	240	10 min	F1	0.149→0.01	Unit shut down immediately, no damage, no hazard.
Model: CZH015420044EUWA (PCB type E, tested with F1: 1ohm, 2W)						
BD1 pin 1-2 #	SC	240	<1s	F1	0.149→0	F1 opened immediately, BD1 damaged, no hazard. Repeat 9 times, total 10 times, same test result came out.
C1 #	SC	240	<1s	F1	0.149→0	F1 opened immediately, BD1 damaged, no hazard. Repeat 9 times, total 10 times, same test result came out.
C2 #	SC	240	<1s	F1	0.149→0	F1 opened immediately, BD1 damaged, no hazard. Repeat 9 times, total 10 times, same test result came out.
U1 pin 5,6-4 #	SC	240	<1s	F1	0.149→0	F1 opened immediately, BD1, U1 damaged, no hazard. Repeat 9 times, total 10 times, same test result came out.
U1 pin 5,6-7,8 #	SC	240	<1s	F1	0.149→0	F1 opened immediately, BD1, U1 damaged, no hazard. Repeat 9 times, total 10 times, same test result came out.

IEC 61558-2-16						
Clause	Requirement + Test				Result - Remark	Verdict
U1 pin 1-5,6 #	SC	240	<1s	F1	0.149→0	F1 opened immediately, BD1, U1 damaged, no hazard. Repeat 9 times, total 10 times, same test result came out.
U1 pin 1-5,6 #	SC	240	<1s	F1	0.149→0	F1 opened immediately, BD1, U1 damaged, no hazard. Repeat 9 times, total 10 times, same test result came out.
R10 #	SC	240	<1s	F1	0.149→0	F1 opened immediately, BD1, U1 damaged, no hazard. Repeat 9 times, total 10 times, same test result came out.
Model: CZH015420044EUWQ (PCB type A, tested with F1: T2A, 250VAC)						
BD1 pin 1-2 #	SC	240	<1 s	F1	0.162→0	F1 opened immediately, BD1 damaged, no hazard.
C1 #	SC	240	<1 s	F1	0.162→0	F1 opened immediately, BD1 damaged, no hazard.
C2 #	SC	240	<1 s	F1	0.162→0	F1 opened immediately, BD1 damaged, no hazard.
U1 pin 1-4	SC	240	10 min	F1	0.162→0.01	Unit shut down immediately, no damage, no hazard.
U1 pin 1-7,8	SC	240	10 min	F1	0.162→0.01	Unit shut down immediately, no damage, no hazard.
U1 pin 5,6-4 #	SC	240	<1 s	F1	0.162→0	F1 opened immediately, BD1, U1 damaged, no hazard.
U1 pin 5,6-7,8 #	SC	240	<1 s	F1	0.162→0	F1 opened immediately, BD1, U1 damaged, no hazard.
U1 pin 1-5,6 #	SC	240	<1 s	F1	0.162→0	F1 opened immediately, BD1, U1 damaged, no hazard.
R10 #	SC	240	<1 s	F1	0.162→0	F1 opened immediately, BD1, U1 damaged, no hazard.
T1 pin 1-2	SC	240	10 min	F1	0.162→0.01	Unit shut down immediately, no damage, no hazard.
T1 pin 4-5	SC	240	10 min	F1	0.162→0.01	Unit shut down immediately, no damage, no hazard.
T1 pin 6-7	SC	240	10 min	F1	0.162→0.01	Unit shut down immediately, no damage, no hazard.
D3	SC	240	10 min	F1	0.162→0.01	Unit shut down immediately, no damage, no hazard.
C10	SC	240	10 min	F1	0.162→0.01	Unit shut down immediately, no damage, no hazard.
Output	SC	240	10 min	F1	0.162→0.01	Unit shut down immediately, no damage, no hazard.
Model: CZH015420044EUWQ (PCB type A, tested with F1: 1ohm, 2W)						
BD1 pin 1-2 #	SC	240	<1s	F1	0.162→0	F1 opened immediately, BD1 damaged, no hazard. Repeat 9 times, total 10 times, same test result came out.

IEC 61558-2-16						
Clause	Requirement + Test				Result - Remark	Verdict
C1 #	SC	240	<1s	F1	0.162→0	F1 opened immediately, BD1 damaged, no hazard. Repeat 9 times, total 10 times, same test result came out.
C2 #	SC	240	<1s	F1	0.162→0	F1 opened immediately, BD1 damaged, no hazard. Repeat 9 times, total 10 times, same test result came out.
U1 pin 5,6-4 #	SC	240	<1s	F1	0.162→0	F1 opened immediately, BD1, U1 damaged, no hazard. Repeat 9 times, total 10 times, same test result came out.
U1 pin 5,6-7,8 #	SC	240	<1s	F1	0.162→0	F1 opened immediately, BD1, U1 damaged, no hazard. Repeat 9 times, total 10 times, same test result came out.
U1 pin 1-5,6 #	SC	240	<1s	F1	0.162→0	F1 opened immediately, BD1, U1 damaged, no hazard. Repeat 9 times, total 10 times, same test result came out.
U1 pin 1-5,6 #	SC	240	<1s	F1	0.162→0	F1 opened immediately, BD1, U1 damaged, no hazard. Repeat 9 times, total 10 times, same test result came out.
R10 #	SC	240	<1s	F1	0.162→0	F1 opened immediately, BD1, U1 damaged, no hazard. Repeat 9 times, total 10 times, same test result came out.
Model: CZH015050300EUUG (PCB type F, tested with F1: T2A, 250VAC)						
BD1 pin 1-2 #	SC	240	<1 s	F1	0.142→0	F1 opened immediately, BD1 damaged, no hazard.
C1 #	SC	240	<1 s	F1	0.142→0	F1 opened immediately, BD1 damaged, no hazard.
C2 #	SC	240	<1 s	F1	0.142→0	F1 opened immediately, BD1 damaged, no hazard.
U1 pin 1-4	SC	240	10 min	F1	0.142→0.01	Unit shut down immediately, no damage, no hazard.
U1 pin 1-7,8	SC	240	10 min	F1	0.142→0.01	Unit shut down immediately, no damage, no hazard.
U1 pin 5,6-4 #	SC	240	<1 s	F1	0.142→0	F1 opened immediately, BD1, U1 damaged, no hazard.
U1 pin 5,6-7,8 #	SC	240	<1 s	F1	0.142→0	F1 opened immediately, BD1, U1 damaged, no hazard.
U1 pin 1-5,6 #	SC	240	<1 s	F1	0.142→0	F1 opened immediately, BD1, U1 damaged, no hazard.
R10 #	SC	240	<1 s	F1	0.142→0	F1 opened immediately, BD1, U1 damaged, no hazard.
T1 pin 1-2	SC	240	10 min	F1	0.142→0.01	Unit shut down immediately, no damage, no hazard.

IEC 61558-2-16						
Clause	Requirement + Test				Result - Remark	Verdict
T1 pin 4-5	SC	240	10 min	F1	0.142→ 0.01	Unit shut down immediately, no damage, no hazard.
T1 pin 6-7	SC	240	10 min	F1	0.142→ 0.01	Unit shut down immediately, no damage, no hazard.
D3	SC	240	10 min	F1	0.142→ 0.01	Unit shut down immediately, no damage, no hazard.
C10	SC	240	10 min	F1	0.142→ 0.01	Unit shut down immediately, no damage, no hazard.
Output	SC	240	10 min	F1	0.142→ 0.01	Unit shut down immediately, no damage, no hazard.
Model: CZH015050300EUUG (PCB type F, tested with F1: 1ohm, 2W)						
BD1 pin 1-2 #	SC	240	<1s	F1	0.142→ 0	F1 opened immediately, BD1 damaged, no hazard. Repeat 9 times, total 10 times, same test result came out.
C1 #	SC	240	<1s	F1	0.142→ 0	F1 opened immediately, BD1 damaged, no hazard. Repeat 9 times, total 10 times, same test result came out.
C2 #	SC	240	<1s	F1	0.142→ 0	F1 opened immediately, BD1 damaged, no hazard. Repeat 9 times, total 10 times, same test result came out.
U1 pin 5,6-4 #	SC	240	<1s	F1	0.142→ 0	F1 opened immediately, BD1, U1 damaged, no hazard. Repeat 9 times, total 10 times, same test result came out.
U1 pin 5,6-7,8 #	SC	240	<1s	F1	0.142→ 0	F1 opened immediately, BD1, U1 damaged, no hazard. Repeat 9 times, total 10 times, same test result came out.
U1 pin 1-5,6 #	SC	240	<1s	F1	0.142→ 0	F1 opened immediately, BD1, U1 damaged, no hazard. Repeat 9 times, total 10 times, same test result came out.
U1 pin 1-5,6 #	SC	240	<1s	F1	0.142→ 0	F1 opened immediately, BD1, U1 damaged, no hazard. Repeat 9 times, total 10 times, same test result came out.
R10 #	SC	240	<1s	F1	0.142→ 0	F1 opened immediately, BD1, U1 damaged, no hazard. Repeat 9 times, total 10 times, same test result came out.

IEC 61558-2-16			
Clause	Requirement + Test	Result - Remark	Verdict
<p>Supplementary information:</p> <ol style="list-style-type: none">1. "SC" means short-circuited test, "OC" means open-circuited test; U_o means output voltage at normal load, U_{oc} means output voltage without load.2. The appliance didn't emit flames, molten metal, or poisonous or ignitable gas in hazardous amounts and temperature exceed the values shown in table 15 during the tests.3. All the test samples have passed the Hi-Pot test between primary and secondary (2870Va.c., 1min).4. # means all types of fuses or fusible resistors considered for tests and got the same results, no explode, no hazards; when fuse F1 opened fault test, the current through fuse is greater than 5.5A.5. All tests were considered in AC 90V also, same results obtained.6. The no-load output voltage was not increase by more than 10% of its no-load output voltage in normal use during and after the fault tests.			

IEC 61558-2-16			
Clause	Requirement + Test	Result - Remark	Verdict
AA	Annex AA		N/A
	Partial discharge (PD) test		N/A
BB	Annex BB		N/A
	Particular requirements for associated transformers for switch mode power supplies with internal frequencies > 500 Hz		N/A
	See separate test report-form for these Annex.		N/A
BB.8	MARKING AND OTHER INFORMATION		N/A
BB.8.2	Marking for transformers IP00 or for associated transformers: type and trademark, instruction sheets		N/A
BB.8.11	Correct symbols:		N/A
	Volts		N/A
	Amperes		N/A
	Volt amperes (or volt-amperes reactive for reactors)		N/A
	Watts		N/A
	Hertz		N/A
	Input		N/A
	Output		N/A
	Direct current		N/A
	Neutral		N/A
	Single-phase a.c.		N/A
	Three-phase a.c.		N/A
	Three-phase and neutral a.c.		N/A
	Power factor		N/A
	Class II construction		N/A
	Class III construction		N/A
	Equipment of overvoltage category I		N/A
	Equipment of overvoltage category II		N/A
	Equipment of overvoltage category III		N/A
	Equipment of overvoltage category IV		N/A
	Fuse-link		N/A
	Rated max. ambient temperature		N/A
	Rated minimum ambient temperature		N/A
	Rated minimum temperature		N/A
	Frame or core terminal		N/A
	Protective earth		N/A

IEC 61558-2-16			
Clause	Requirement + Test	Result - Remark	Verdict
	IP number		N/A
	Earth (ground for functional earth)		N/A
	For indoor use only		N/A
	To indicate that the appliance is intended to be usable up to the maximum altitude 3 000 m.		N/A
	To indicate that the power supply unit shall not be used, if pins of the plug part are damaged.		N/A
	Additional Symbols (IEC 61558-2-16:09)		N/A
	SMPS incorporating a Fail-safe separating transformer		N/A
	SMPS incorporating a Non-short-circuit-proof separating transformer		N/A
	SMPS incorporating a Short-circuit-proof separating transformer (inherently or non-inherently)		N/A
	SMPS incorporating a Fail-safe isolating transformer		N/A
	SMPS incorporating a Non-short-circuit-proof isolating transformer		N/A
	SMPS incorporating a Short-circuit-proof isolating transformer (inherently or non-inherently)		N/A
	SMPS incorporating a Fail-safe safety isolating transformer		N/A
	SMPS incorporating a Non-short-circuit-proof safety isolating transformer		N/A
	SMPS incorporating a Short-circuit-proof safety isolating transformer (inherently or non-inherently)		N/A
	SMPS incorporating a Fail-safe auto-transformer		N/A
	SMPS incorporating a Non-short-circuit proof auto-transformer		N/A
	SMPS incorporating a Short-circuit proof auto-transformer (inherently or non-inherently)		N/A
	SMPS (Switch mode power supply unit)		N/A
BB.9	PROTECTION AGAINST ELECTRIC SHOCK		N/A
BB.10	CHANGE OF INPUT VOLTAGE SETTING		N/A
BB.11	OUTPUT VOLTAGE AND OUTPUT CURRENT UNDER LOAD		N/A
BB.12	NO-LOAD OUTPUT VOLTAGE (see supplementary requirements in Part 2)		N/A
BB.13	SHORT-CIRCUIT VOLTAGE		N/A

IEC 61558-2-16			
Clause	Requirement + Test	Result - Remark	Verdict
BB.14	HEATING		N/A
BB.14.2	Application of 14.1 or 14.3 according to the insulation system		N/A
BB.14.2.1	Class of isolating system (classified materials according to IEC 60 085 and IEC 60 216)		N/A
BB.14.2.2	No classified material, or system but the measured temperature does not exceed the value of Class A		N/A
BB.14.2.3	No classified material or system but the measured temperature exceeds the value for Class A, the live parts of the transformers are submitted to the test of 14.3		N/A
BB.14.3	Accelerated ageing test for undeclared class of isolating system		N/A
	Cycling test (10 cycles):		N/A
	– measuring of the no-load input current (mA)		N/A
BB.14.3.1	– heat run (temperature in table 2)		N/A
BB.14.3.2	– vibration test: 30 min; amplitude 0,35 mm; frequency range: 10 Hz, 55 Hz, 10 Hz		N/A
BB.14.3.3	– moisture treatment (48 h, 17.2)		N/A
BB.14.3.4	Measurements and tests at the beginning and after each test:		N/A
	– deviation of the no-load input current, measured at the beginning of the test is $\leq 30\%$		N/A
	– insulation resistance acc. cl.18.1 and 18.2		N/A
	– electric strength, no breakdown (18.3); 2 min; test voltage 35% of specified value (table VI)		N/A
	– Transformers (50 or 60 Hz version) are tested after the dielectric strength test as follows: under no load; duration: 5 min; Upri(V):1,2 times rated supply voltage; frequency (Hz): 2 times rated frequency		N/A
BB.15	SHORT-CIRCUIT AND OVERLOAD PROTECTION		N/A
BB.16	MECHANICAL STRENGTH		N/A
BB.17	PROTECTION AGAINST HARMFUL INGRESS OF WATER AND MOISTURE		N/A
BB.18	INSULATION RESISTANCE AND ELECTRIC STRENGTH		N/A
BB.18.2	Insulation resistance between:		N/A
	– live parts and body for basic insulation $\geq 2 \text{ M}\Omega$		N/A
	– live parts and body for reinforced insulation $\geq 7 \text{ M}\Omega$		N/A
	– input circuits and output circuits for basic insulation $\geq 2 \text{ M}\Omega$		N/A
	– input circuits and output circuits for double or reinforced insulation $\geq 5 \text{ M}\Omega$		N/A

IEC 61558-2-16			
Clause	Requirement + Test	Result - Remark	Verdict
	– each input circuit and all other input circuits connected together $\geq 2 \text{ M}\Omega$		N/A
	– each output circuit and all other output circuits connected together $\geq 2 \text{ M}\Omega$		N/A
	– hazardous live parts and metal parts with basic insulation (Class II transformers) $\geq 2 \text{ M}\Omega$		N/A
	– body and metal parts with basic insulation (Class II transformers) $\geq 5 \text{ M}\Omega$		N/A
	– metal foil in contact with inner and outer surfaces of enclosures $\geq 7 \text{ M}\Omega$		N/A
BB.18.3	Electric strength test (1 min): no flashover or breakdown:		N/A
	1) basic insulation between input circuits and output circuits; working voltage (V); test voltage (V)		N/A
	2) double or reinforced insulation between input circuits and output circuits; working voltage (V); test voltage (V)		N/A
	3) basic or supplementary insulation between:		N/A
	a) live parts of different polarity; working voltage (V); test voltage (V)		N/A
	b) live parts and the body if intended to be connected to protective earth		N/A
	c) inlet bushings and cord guards and anchorages		N/A
	d) live parts and an intermediate conductive part		N/A
	e) intermediate conductive parts and body ..		N/A
	4) Reinforced insulation between the body and live parts; working voltage (V); test voltage (V)		N/A
	5) Functional insulation for windings intended to be connected in series or parallel (test voltage = working voltage + 500 V) (IEC 61558-2-16:2009)		N/A
18.102 (A1)	Partial discharge tests according IEC 60664-1, if the working voltage is $> 750 \text{ V}$ peak		N/A
	Partial discharge is $\leq 10 \text{ pC}$ at time P2 See Fig. 19.101		N/A
BB.19	CONSTRUCTION		N/A
BB.19.1	General construction		N/A
BB.19.1.1	General		N/A
BB.19.1.2	Auto-transformers		N/A

IEC 61558-2-16			
Clause	Requirement + Test	Result - Remark	Verdict
BB.19.1.2.1	For plug connected auto-transformers with rated input voltage > rated output voltage the potential to earth shall not exceed the rated output voltage.		N/A
BB.19.1.2.2	Polarised input and output plug and socket-outlet system: an instruction is given with the information, that the transformer shall not be used with non-polarised plug and socket outlet system.		N/A
BB.19.1.2.3	A polarity detecting device only energises the output in the case: output potential to earth \leq rated output voltage, also with reversed input plug.		N/A
	– The contact separation of the device is \geq 3mm		N/A
	– A current to earth does not exceed 0,75 mA.		N/A
	– All tests are repeated under fault conditions of H.3.3 of annex H of part 1. The potential to earth does not exceed the max output voltage for more than 5 s.		N/A
BB.19.1.3	Separating transformers		N/A
BB.19.1.3.1	Input and output circuits electrically separated.		N/A
BB.19.1.3.2	The insulation between input and output winding(s) consist of basic insulation		N/A
	Class I SMPS		N/A
	– Insulation between input windings and body consist of basic insulation		N/A
	– Insulation between output windings and body consist of basic insulation		N/A
	Class II SMPS		N/A
	– Insulation between input windings and body consist of double or reinforced insulation		N/A
	– Insulation between output windings and body consist of double or reinforced insulation		N/A
BB.19.1.3.3	The insulation between input windings and intermediate conductive parts and the output windings and intermediate part consist of basic insulation		N/A
	For class I SMPS the insulation between input and output windings via the intermediate conductive parts consist of basic insulation		N/A
	For class II SMPS the insulation between input winding and the body and between the output windings and the body via the intermediate conductive parts consist of double or reinforced insulation.		N/A
BB.19.1.3.4	Parts of output circuits may be connected to protective earth		N/A

IEC 61558-2-16			
Clause	Requirement + Test	Result - Remark	Verdict
BB.19.1.3.5	No direct contact between output circuits and the body, unless:		N/A
	– Allowed for associated transformers by the equipment standard		N/A
BB.19.1.4	Isolating transformers and safety isolating transformers		N/A
BB.19.1.4.1	Input and output circuits electrically separated		N/A
	No possibility of any connection between these circuits		N/A
BB.19.1.4.2	The insulation between input and output winding(s) consist of double or reinforced insulation (exception see 19.1.4.4)		N/A
	Class I transformers not intended for connection to the mains by a plug:		—
	– Insulation between input windings and body connected to earth consist of basic insulation rated to the input voltage		N/A
	– Insulation between output windings and body, connected to earth consist of basic insulation rated for the output voltage		N/A
	Class I transformers intended for connection to the mains by a plug:		N/A
	– Insulation between input windings and body connected to earth consist of basic insulation rated to the working voltage		N/A
	– Insulation between output windings and body, connected to earth consist of supplementary insulation rated for the working voltage		N/A
	Class II transformers		N/A
	– Insulation between input windings and body consist of double or reinforced insulation rated to the input voltage		N/A
	– Insulation between output windings and body consist of double or reinforced insulation, rated to the output voltage		N/A
BB.19.1.4.3	For transformers with intermediate conductive parts not connected to the body (between input/output):		-
BB.19.1.4.3.1	For class I and class II transformers the insulation between input and output windings, via intermediate conductive parts, consist of double or reinforced insulation, rated to the working voltage.		N/A

IEC 61558-2-16			
Clause	Requirement + Test	Result - Remark	Verdict
	– For class II transformers the insulation between input winding and the body and between the output windings and the body via the intermediate conductive parts consist of double or reinforced insulation. (rated to the input voltage, for SELV circuits only basic insulation to the body)		N/A
	– For transformers, different from independent, the insulation between input and output windings, via intermediate conductive parts, consist of double or reinforced insulation, rated to the working voltage.		N/A
BB.19.1.4.3.2	Class I transformers with earthed core, and not allowed for class II equipment		N/A
	– Insulation from the input to the earthed core: basic insulation rated for the input voltage		N/A
	– Insulation from the output voltage to the earthed core: basic insulation rated for the output voltage		N/A
BB.19.1.4.3.3	Insulation between : input to intermediate conductive parts and output and intermediate parts consist of at least basic insulation		N/A
	– If the insulation from input or output to the intermediate metal part is less than basic insulation, the part is considered to be connected to input or output.		N/A
BB.19.1.4.4	For class I transformers, with protective screen, not connected to the mains by a plug the following conditions comply:		N/A
	– The insulation between input winding and protective screen consist of basic insulation (rated input voltage)		N/A
	– The insulation between output winding and protective screen consist of basic insulation (rated output voltage)		N/A
	– The protective screen consist of metal foil or a wire wound screen extending the full width of the windings and has no gaps or holes		N/A
	– Where the protective screen does not cover the entire width of the input winding, additional insulation to ensure double insulation in this area, is used.		N/A
	– If the screen is made by a foil, the turns are isolated, overlap at least 3 mm		N/A
	– The cross-section of the screen and the lead out wire is at least corresponding to the rated current of the overload device		N/A
	– The lead out wire is soldered or fixed to the protective screen.		N/A

IEC 61558-2-16			
Clause	Requirement + Test	Result - Remark	Verdict
	Protective screening is not allowed for transformers with plug connection to the mains		N/A
BB.19.1.4.5	No connection between output circuit and protective earth, except of associated transformers (allowed by equipment standard) or 19.8 is fulfilled.		N/A
BB.19.1.4.6	No connection between output circuit and body, except of associated transformers (allowed by equipment standard)		N/A
BB.19.1.4.7	The distance between input and output terminals for the connection of external wiring is ≥ 25 mm		N/A
BB.19.1.4.8	Portable transformers having an rated output ≤ 630 VA shall be class II.		N/A
BB.19.1.4.9	No connection between output circuit and body except of associated transformers (allowed by equipment standard)		N/A
BB.19.1.4.10	Protective screening is not allowed for transformers with plug connection to the mains		N/A
BB.19.12	Windings construction		N/A
BB.19.12.1	Undue displacement in all types of transformers not allowed:		N/A
	– of input or output windings or turns thereof		N/A
	– of internal wiring or wires for external connection		N/A
	– of parts of windings or of internal wiring in case of rupture or loosening		N/A
BB.19.12.2	Serrated tape:		N/A
	– distance through insulation according to table 13		N/A
	– one additional layer of serrated tape, and		N/A
	– one additional layer without serration		N/A
	– in case of cheek less bobbins the end turns of each layer shall be prevented from being displaced		N/A
BB.19.12.3	Insulated windings wires providing basic, supplementary or reinforced insulation, meet the following requirements:		N/A
	<ul style="list-style-type: none"> Multi-layer extruded or spirally wrapped insulation, passed the tests of annex K 		N/A
	<ul style="list-style-type: none"> Basic insulation: two wrapped or one extruded wire 		N/A
	<ul style="list-style-type: none"> Supplementary insulation: two layers, wrapped or extruded 		N/A
	<ul style="list-style-type: none"> Reinforced insulation: three layers wrapped or extruded 		N/A

IEC 61558-2-16			
Clause	Requirement + Test	Result - Remark	Verdict
	Spirally wrapped insulation:		N/A
	<ul style="list-style-type: none"> creepage distances between wrapped layers > cl. 26 _ P1 values 		N/A
	<ul style="list-style-type: none"> path between wrapped layers sealed, the test voltage of K2 is multiplied with 1,35 		N/A
	<ul style="list-style-type: none"> test 26.2.4 – Test A, passed for wrapped layers 		N/A
	<ul style="list-style-type: none"> the finished component pass the electric strength test according to cl. 18.3 		N/A
a)	Insulated winding wire used for basic or supplementary insulation in a wound part:		N/A
	<ul style="list-style-type: none"> comply with annex K 		N/A
	<ul style="list-style-type: none"> two layers for supplementary insulation 		N/A
	<ul style="list-style-type: none"> one layer for basic insulation 		N/A
	<ul style="list-style-type: none"> one layer for mechanical separation between the insulated wires of primary and secondary. This layer fulfils the requirement of basic insulation. 		N/A
b)	Insulated winding wire used for reinforced insulation in a wound part:		N/A
	<ul style="list-style-type: none"> comply with annex K 		N/A
	<ul style="list-style-type: none"> three layers 		N/A
	<ul style="list-style-type: none"> relevant dielectric strength test of 18.3 		N/A
	Where the insulated winding wire is wound:		N/A
	<ul style="list-style-type: none"> upon metal or ferrite cores 		N/A
	<ul style="list-style-type: none"> upon enamelled wire 		N/A
	<ul style="list-style-type: none"> under enamelled wire 		N/A
	<ul style="list-style-type: none"> one layer for mechanical separation between the insulated wires and the core or the enamelled wires is required. This layer fulfils the requirement of basic insulation. 		N/A
	<ul style="list-style-type: none"> both windings shall not touch each other and also not the core. 		N/A
	100 % routine test of Annex K3 of part 1 is fulfilled		N/A
	no creepage distances and clearances for insulated winding wires		N/A
c)	Toroidal cores used with TIW wires for double or reinforced insulation between the primary and secondary circuits shall comply with the following:		N/A
	4) a coating which fulfils the requirements of basic insulation between a winding and the core		N/A

IEC 61558-2-16			
Clause	Requirement + Test	Result - Remark	Verdict
	5) The primary winding consists of TIW wire with 3 layers (reinforced insulation) and the secondary winding consists of enamelled wire. These independent windings shall not be able to contact each other either by mechanical separation or a gap which fulfil the dielectric strength tests for basic insulation.		N/A
	6) For polyfilar windings (primary and secondary windings in contact with each other), the primary winding consists of TIW wire with 3 layers and the secondary winding consists of a TIW wire with 1 layer (requirements for primary and secondary windings can be changed). This construction also is allowed for use with EE-cores or similar.		N/A
d)	Toroidal cores used with FIW wires for double or reinforced insulation between the primary and secondary circuits shall comply with the following:		N/A
	4) a coating, which fulfil the requirements of basic insulation.		N/A
	5) The primary winding consists of FIW wire for reinforced insulation and the secondary winding consist of FIW wire – of basic insulation. These independent windings shall not be able to contact each other either by mechanical separation or a gap which fulfil the dielectric strength test for basic insulation.		N/A
	6) For polyfilar windings (primary and secondary windings in contact with each other), the primary winding and the secondary winding consist of FIW wire for reinforced insulation. This construction also is allowed to use for EE-core or similar.		N/A
e)	Toroidal cores used with TIW in combination with FIW wire, for double or reinforced insulation between the primary and secondary circuits shall comply with the following:		N/A
	4) a coating, which fulfils the requirements of basic insulation.		N/A
	5) The primary winding consists of FIW wire for reinforced insulation, and the secondary winding consists of TIW wire for basic insulation (1 layer). These independent windings shall not be able to contact each other either by mechanical separation or a gap which fulfil the dielectric strength tests for basic insulation.		N/A

IEC 61558-2-16			
Clause	Requirement + Test	Result - Remark	Verdict
	6) For polyfilar windings (primary and secondary windings in contact with each other), the primary winding consists of TIW wire for reinforced insulation (3 layer) and the secondary winding consists of FIW wire for reinforced insulation. This construction also is allowed for use with EE-cores or similar.		N/A
f)	Toroidal cores used with TIW in combination with FIW wire, for basic insulation between the primary and secondary circuits shall comply with the following:		N/A
	1) a coating, which fulfils the requirements of basic insulation		N/A
	2) The primary winding consists of FIW wire for basic insulation, and the secondary winding consists of TIW wire for basic insulation (1 layer). These independent windings shall not be able to contact each other either by mechanical separation or a gap which fulfils the dielectric strength tests for basic insulation.		N/A
	3) For polyfilar windings (primary and secondary windings in contact with each other), the primary winding consists of TIW wire for supplementary insulation (2 layers) and the secondary winding consists of FIW wire for basic insulation. This construction also is allowed for use with EE-cores or similar.		N/A
	4) Further polyfilar constructions with FIW and TIW wires in combination with enamelled wires for basic insulation only: 4.1) Primary winding consists of enamelled wire, secondary winding consists of FIW wire for reinforced insulation 4.2) Primary winding consists of enamelled wire, secondary winding consists of TIW wire for reinforced insulation		N/A
BB.19.12.3.1	Max. class F for transformers which use FIW-wire		N/A
BB.19.12.3.2	FIW wires comply with IEC 60851-5:2008, IEC 60317-0-7 and IEC 60317-56.		N/A
	<ul style="list-style-type: none"> other nominal diameter as mentioned in table 24 can be calculated with the Formula (6) in 26.3.5: 		N/A
	FIW wire used for basic or supplementary insulation for transformers according 19.1.3:		-
	<ul style="list-style-type: none"> the test voltage of table 14, based on the working voltage of basic or supplementary insulation, comply with the min. voltage strength of table 24 		N/A

IEC 61558-2-16			
Clause	Requirement + Test	Result - Remark	Verdict
	<ul style="list-style-type: none"> one layer for mechanical separation is located between the insulated wires of primary and secondary. This layer fulfil the requirement of basic insulation 		N/A
	<ul style="list-style-type: none"> between FIW and enamelled wire, no requirements of creepage distances and clearances 		N/A
	<ul style="list-style-type: none"> no touch of FIW and enamelled wires 		N/A
	FIW wire used for double or reinforced insulation for transformers according 19.1.4:		N/A
	<ul style="list-style-type: none"> the test voltage of table 14, based on the working voltage of basic or supplementary insulation, comply with the min. voltage strength of table 24 		N/A
	<ul style="list-style-type: none"> for primary and secondary winding FIW-wire for basic insulation is used 		N/A
	<ul style="list-style-type: none"> one layer for mechanical separation is located between the insulated wires of primary and secondary. This layer fulfil the requirement of basic insulation 		N/A
	<ul style="list-style-type: none"> no touch between the basic insulated PRI and SEC FIW-wires 		N/A
	<ul style="list-style-type: none"> between PRI- and SEC-FIW wires, no requirements of creepage distances and clearances 		N/A
	Alternative construction used for reinforced insulation (reinforced insulated FIW wire and enamelled wire)		N/A
	<ul style="list-style-type: none"> the test voltage of table 14, based on the working voltage reinforced insulation, comply with the min. voltage strength of table 24 		N/A
	<ul style="list-style-type: none"> one layer for mechanical separation is located between the reinforced insulated FIW wire and the enamelled wire. This layer fulfil the requirement of basic insulation 		N/A
	<ul style="list-style-type: none"> no touch between the FIW wire and the enamelled wire 		N/A
	<ul style="list-style-type: none"> between the reinforced FIW wire and any other parts, no requirements of creepage distances and clearances exist 		N/A
	Alternative construction with FIW wires, basic or supplementary insulated for transformers with double or reinforced insulation:		-

IEC 61558-2-16			
Clause	Requirement + Test	Result - Remark	Verdict
	<ul style="list-style-type: none"> the test voltage of table 14, based on the working voltage of basic or supplementary insulation, comply with the min. voltage strength of table 24 		N/A
	<ul style="list-style-type: none"> PRI or SEC basic insulated FIW wire and to the other winding (enamelled wire) requirements of supplementary insulation 		N/A
	<ul style="list-style-type: none"> creepage distances and clearances between the basic insulated FIW wire and the enamelled wire for basic or supplementary insulation are required. 		N/A
	Where the FIW wire is wound		N/A
	<ul style="list-style-type: none"> upon metal or ferrite cores 		N/A
	<ul style="list-style-type: none"> one layer for mechanical separation between the insulated wires and the core or the enamelled wires is required. This layer fulfils the requirement of basic insulation. 		N/A
	<ul style="list-style-type: none"> both windings shall not touch each other and also not the core. 		N/A
BB.20	COMPONENTS		N/A
BB.21	INTERNAL WIRING		N/A
BB.22	SUPPLY CONNECTION AND EXTERNAL FLEXIBLE CABLES AND CORDS		N/A
BB.23	TERMINALS FOR EXTERNAL CONDUCTORS		N/A
BB.24	PROVISION FOR PROTECTIVE EARTHING		N/A
BB.25	SCREWS AND CONNECTIONS		N/A
BB.26	CREEPAGE DISTANCES AND CLEARANCES		N/A
BB.26.1	See 26.101		N/A
BB.26.2	Creepage distances (cr) and clearances (cr)		N/A
BB.26.2.1	Windings covered with adhesive tape		N/A
	– the values of pollution degree 1 are fulfilled		N/A
	– all isolating material are classified acc. to IEC 60085 and IEC 60216		N/A
	– test A of 26.2.3 is fulfilled		N/A
BB.26.2.2	Uncemented insulating parts pollution degree P2 or P3		N/A
	– all isolating material are classified acc. to IEC 60085 and IEC 60216		N/A
	– values of pollution degree 1 are not applicable		N/A
BB.26.2.3	Cemented insulating parts		N/A
	– all isolating materials are classified acc. to IEC 60085 and IEC 60216		N/A

IEC 61558-2-16			
Clause	Requirement + Test	Result - Remark	Verdict
	– values of distance through insulation (dti) are fulfilled		N/A
	– creepage distances and clearances are not required		N/A
	– test A of this sub clause is fulfilled		N/A
	Test A		N/A
	– thermal class		N/A
	– working voltage		N/A
	– Test with three specially specimens, with uninsulated wires, without impregnation or potting	(See appended table)	N/A
	Two of the three specimens are subjected to:		N/A
	– the relevant humidity treatment according to 17.2 (48 h)		N/A
	– the relevant dielectric strength test of 18.3 multiplied with factor 1,35		N/A
	– One of the three specimens is subjected to the relevant dielectric strength test of 18.3 multiplied by the factor 1,35 immediately at the end of the last cycle with high temperature		N/A
	Impulse dielectric test according to 4.1.1.2.1 of IEC 60 664-1 (1,2 / 50 s waveform) – see Annex R of IEC 61558-1		N/A
BB.26.2.4	Enclosed parts, by impregnation or potting		N/A
BB.26.2.4.1	– The requirements of reduced values as stated for pollution degree 1 (P1) are fulfilled		N/A
	– all isolating materials are classified acc. to IEC 60085 and IEC 60216		N/A
	Test B		N/A
	– thermal class		N/A
	– working voltage		N/A
	– Test with three specially specimens, potted or impregnated. The dielectric strength test is applied directly to the joint.	(See appended table)	N/A
	Two of the three specimens are subjected to:		N/A
	– the relevant humidity treatment according to 17.2 (48 h)		N/A
	– the relevant dielectric strength test of 18.3 multiplied with factor 1,25		N/A
	– One of the three specimens is subjected to the relevant dielectric strength test of 18.3 multiplied by the factor 1,25 immediately at the end of the last cycle with high temperature		N/A

IEC 61558-2-16			
Clause	Requirement + Test	Result - Remark	Verdict
	The three spacemen pass the Impulse dielectric test according to 4.1.1.2.1 of IEC 60 664-1 (1,2 / 50 s waveform) – see Annex R of IEC 61558-1		N/A
BB.26.2.4.2	– The requirements of distance through insulation (dti) are fulfilled. (P1 values are not required)		N/A
	– all isolating materials are classified acc. to IEC 60085 and IEC 60216		N/A
	Test C		N/A
	– thermal class		N/A
	– working voltage		N/A
	– Test with three specimens, potted or impregnated. (finished components)	(See appended table)	N/A
	– Neither cracks, nor voids in the insulating compounds		N/A
	Two of the three specimens are subjected to:		N/A
	– the relevant humidity treatment according to 17.2 (48 h)		N/A
	– the relevant dielectric strength test of 18.3 multiplied with factor 1,35		N/A
	– One of the three specimens is subjected to the relevant dielectric strength test of 18.3 multiplied by the factor 1,35 immediately at the end of the last cycle with high temperature		N/A
	The three spacemen pass the Impulse dielectric test according to 4.1.1.2.1 of IEC 60 664-1 (1,2 / 50 us waveform) – see Annex R of IEC 61558-1		N/A
BB.26.3	Distance through insulation		N/A
	For double or reinforced insulation, the required values of Tables 13, C1, and D1 – boxes 2b, 2c and 7 are fulfilled		N/A
	The insulation fulfil the material classification according IEC 60085 or 60216 or the test of 14.3		N/A
BB.26.3.1	Reduced values of the thickness of insulation for supplementary or reinforced insulation are allowed if the following conditions are fulfilled:		N/A
	– the isolating materials are classified acc. to IEC 60085 and IEC 60216		N/A
	– the test of 14.3 is fulfilled		N/A
	– If both requirements are fulfilled, the required values for solid insulation can be multiplied by 0,4		N/A

IEC 61558-2-16			
Clause	Requirement + Test	Result - Remark	Verdict
	– Minimum thickness of reinforced insulation $\geq 0,2$ mm		N/A
	– Minimum thickness of supplementary insulation $\geq 0,1$ mm		N/A
BB.26.3.2	Insulation in thin sheet form		N/A
	– If the layers are non-separable (glued together):		N/A
	– The requirement of 3 layers is fulfilled		N/A
	– The mandrel test according 26.3.3 is fulfilled with 150 N		N/A
	– The required values for d.t.i. of Tables 13, C.1 and D.1 – marked by index "e" is fulfilled.		N/A
	– If the layers are separated:		N/A
	– The requirement of 2 layers is fulfilled		N/A
	– If serrated tape is used, 1 additional layer (serrated) and one additional layer without serration is required		N/A
	– The mandrel test according 26.3.3 is fulfilled on each layer with 50 N		N/A
	– The required values for d.t.i. of Tables 13, C.1 and D.1 – marked by index "e" is fulfilled.		N/A
	– If the layers are separated (alternative:		N/A
	- The requirement of 3 layers is fulfilled		N/A
	– If serrated tape is used, 1 additional layer (serrated) and one additional layer without serration is required		N/A
	– The mandrel test according 26.3.3 is fulfilled on 2/3 of the layers with 100 N		N/A
	– The required values for d.t.i. of Tables 13, C.1 and D.1 – marked by index "e" is fulfilled.		N/A
	Test according to 14.3 and if the isolating materials are classified acc. to IEC 60085 and IEC 60216 no distances through insulation are required for insulation in thin sheet form		N/A
	The figures within square brackets in box 2 and 7 of table 13 (C.1/D.1) are used for insulation in thin sheet form as follows:		N/A
	– rated output > 100 VA values in square brackets apply		N/A
	– rated output ≥ 25 VA ≤ 100 VA 2/3 of the values for thin layers apply		N/A

IEC 61558-2-16			
Clause	Requirement + Test	Result - Remark	Verdict
	– rated output < 25 VA 1/3 of the values for thin layers apply		N/A
BB.26.3.3	Mandrel test of insulation in thin sheet form (specimen of 70 mm width are necessary):		N/A
	– If the layers are non-separable – at least 3 layers glued together fulfil the test:		N/A
	– pull force of 150 N		N/A
	– high voltage test of 5,0 kV or the test voltage of 18.3 multiplied by 1,25 whatever is the greater. No flashover, no breakdown.		N/A
	– If the layers are separable and 2/3 of at least 3 layers fulfil the test.		N/A
	– pull force of 100 N		N/A
	– high voltage test of 5,0 kV or the test voltage of 18.3 multiplied by 1,25 whatever is the greater. No flashover, no breakdowns.		N/A
	– If the layers are separable 1 of at least 2 layers fulfil the test:		N/A
	– pull force of 50 N		N/A
	– high voltage test of 5,0 kV or the test voltage of 18.3 multiplied by 1,25 whatever is the greater. No flashover, no breakdown.		N/A
BB.26.101	Creepage distances, clearances and distances through insulation, specified values according to (IEC 61558-2-16:09):		N/A
	– table 13, material group IIIa (part 1)		N/A
	– table C, material group II (part 1)		N/A
	– table D, material group I (part 1)		N/A
	– working voltage		N/A
	– rated supply frequency 50/60 Hz		N/A
	– rated internal frequency		N/A
	1. Insulation between input and output circuits (basic insulation):		N/A
	a) measured values \geq specified values (mm)		N/A
	2. Insulation between input and output circuits (double or reinforced insulation):		N/A
	a) measured values \geq specified values (mm)		N/A
	b) measured values \geq specified values (mm)		N/A
	c) measured values \geq specified values (mm)		N/A

IEC 61558-2-16			
Clause	Requirement + Test	Result - Remark	Verdict
	3. Insulation between adjacent input circuits: measured values \geq specified values (mm):		N/A
	Insulation between adjacent output circuits: measured values \geq specified values (mm):		N/A
	4. Insulation between terminals for external connection:		N/A
	a) measured values \geq specified values (mm)		N/A
	b) measured values \geq specified values (mm)		N/A
	c) measured values \geq specified values (mm)		N/A
	5. Basic or supplementary insulation:		N/A
	a) measured values \geq specified values (mm)		N/A
	b) measured values \geq specified values (mm)		N/A
	c) measured values \geq specified values (mm)		N/A
	d) measured values \geq specified values (mm)		N/A
	e) measured values \geq specified values (mm)		N/A
	6. Reinforced or double insulation: measured values \geq specified values (mm)		N/A
	7. Distance through insulation:		N/A
	a) measured values \geq specified values (mm)		N/A
	b) measured values \geq specified values (mm)		N/A
	c) measured values \geq specified values (mm)		N/A
BB.26.102	Values of IEC 61558-2-16 applicable for frequency up to 3 MHz (IEC 61558-2-16:09)		N/A
	For frequency above 3 MHz clause 7 of IEC 60664-4 is applicable (high frequency testing)		N/A
BB.26.103	Clearance (IEC 61558-2-16:09)		N/A
	a.) Clearance for frequency \geq 30 kHz according figure 101 two determinations are necessary:		N/A
	– determination based on peak working voltage according Table 104 :		N/A
	Peak working voltage		N/A

IEC 61558-2-16			
Clause	Requirement + Test	Result - Remark	Verdict
	Basic insulation: required / measured		N/A
	Double or reinforced insulation: required / measured value		N/A
	– and alternative if applicable for approximately homogeneous field according to Table 102		N/A
	Peak working voltage		N/A
	Basic insulation: required / measured		N/A
	Double or reinforced insulation: required / measured value		N/A
	– determination based on measured r.m.s. working voltage according Tables 13, C1 and D1 (see clause 26.101)		N/A
	The minimum clearance is the greater of the two values.		N/A
	b.) Clearance for frequency ≤ 30 kHz according figure 101 two determinations are necessary:		N/A
	– determination based on peak working voltage with recurring peak voltages according Table 103 :		N/A
	– determination based on measured r.m.s. working voltage according Tables 13, C1 and D1 (see clause 26.101)		N/A
	The minimum clearance is the greater of the two values.		N/A
BB.26.104	The working voltages of Table 102, 103 and 104 are peak voltages including μ sec peaks IEC 61558-2-16:09)		N/A
	The working voltage according to Table 13 of part 1 are r.m.s. voltages		N/A
BB.26.105	Creepage distances		N/A
	Two determinations of creepage distances are necessary (see Figure 102)		N/A
	– determination based on measured peak working voltage according Tables 105 to 110		N/A
	Peak working voltage		N/A
	Pollution degree		N/A
	Basic or supplementary insulation: required / measured		N/A
	Double or reinforced insulation: required / measured value		N/A
	– determination based on measured r.m.s. working voltage according Tables 13, C1 and D1 (see clause 26.101)		N/A

IEC 61558-2-16			
Clause	Requirement + Test	Result - Remark	Verdict
	If the values based on table 105 to 110 are lower than the relevant values in Tables 13, C.1 or D.1, the higher values shall be applicable		N/A
BB.26.106	Distance through insulation (IEC 61558-2-16:09)		N/A
	Instead of partial discharge with high frequency voltage the test of the distance and the calculation of the electric field is applicable under the following conditions:		N/A
	– the max. frequency is < 10 MHz		N/A
	– the field strength approximately comply with Figure 103		N/A
	– no voids or gaps are present in between the solid insulation		N/A
	For thick layers $d1 \geq 0,75$ the peak value of the field strength is ≤ 2 kV/mm		N/A
	For thin layers $d2 \leq 30 \mu\text{m}$ the peak value of the field strength is ≤ 10 kV/mm		N/A
	For $d1 > d > d2$ equation (1) is used for calculation the field strength		N/A
BB.26.107 (A1)	For transformers with FIW wires the following test is required		N/A
	<ul style="list-style-type: none"> 10 cycles are required 		N/A
	<ul style="list-style-type: none"> 68 h test at max heating temperature + 10°C or test at max. allowed winding temperature based on the insulation class (required in table 1) + 10°C 		N/A
	<ul style="list-style-type: none"> 1 h at 25° C 		N/A
	<ul style="list-style-type: none"> 2 h at 0° C 		N/A
	<ul style="list-style-type: none"> 1 h at 25° C – (next cycle start again with 68 h max winding temp + 10) 		N/A
	<ul style="list-style-type: none"> during the 10 cycles test 2 x working voltage is connected between PRI and SEC 		N/A
	<ul style="list-style-type: none"> after 10 cycle test 2 transformers are subjected to the 17.2 test for 48 h and direct after the 48 h the dielectric strength test of 18.3 (100 % test voltage) is done 		N/A
	<ul style="list-style-type: none"> after the 10 cycle test the third sample is tested at the end of the last cycle in the hot position with the dielectric strength test of 18.3 (100 % test voltage) 		N/A
	<ul style="list-style-type: none"> the partial discharge test according to 18.101 is done after the cycling test and after the high voltage test, if the peak working voltage is >750 V 		N/A
BB.27	RESISTANCE TO HEAT, FIRE AND TRACKING		N/A

IEC 61558-2-16			
Clause	Requirement + Test	Result - Remark	Verdict
IEC 61558-2-16 Annex BB			
Clause	Requirement + Test	Result - Remark	Verdict
BB.E	ANNEX E , GLOW WIRE TEST		N/A
	The test is required according to IEC 60695-2-10 and IEC 60695-2-11 with the following additions:		N/A
BB.E.1	Clause 6, "Severities" of IEC 6095-2-11, apply with the temperature stated in 27.3 of IEC 61558-1		N/A
BB.E2	Clause 8, "Conditioning", of IEC 60695-2-11 apply, preconditioning is required		N/A
BB.E3	Clause 10, "Test Procedure", of IEC 60695-2-11 apply, The tip of the glow wire is applied to the flat side of the surface.		N/A
BB.F	ANNEX F, REQUIREMENTS FOR MANUALLY OPERATED SWITCHES WHICH ARE PARTS OF THE TRANSFORMER		N/A
BB.H	ANNEX H, ELECTRONIC CIRCUITS (IEC 61558-1)		N/A
BB.K	ANNEX K, INSULATED WINDING WIRES FOR USE AS MULTIPLE LAYER INSULATION		N/A
BB.K.1	Wire construction:		N/A
	<ul style="list-style-type: none"> insulated winding wire for basic or supplementary insulation (see 19.12.3) 		N/A
	<ul style="list-style-type: none"> insulated winding wire for reinforced insulation (see 19.12.3) 		N/A
	<ul style="list-style-type: none"> solid circular winding wires and stranded winding wires with 0,05 to 5 mm diameter 		N/A
	<ul style="list-style-type: none"> spirally wrapped insulation - overlapping 		N/A
BB.K.2	Type tests		N/A
BB.K.2.1	General Tests between ambient temperature between 15° C and 35° C and at an humidity between 45% and 75 %		N/A
BB K.2.2	Electric strength test		N/A
BB K.2.2.1	Solid circular winding wires and stranded winding wires		N/A
	Test samples prepared according to clause 4.4.1 of IEC 60851-5:2008 (twisted pair)		N/A
	Dielectric strength test: 6 kV for reinforced insulation		N/A
	Dielectric strength test: 3 kV for basic or supplementary insulation		N/A
BB K.2.2.2	Square or rectangular wires .		N/A
	Test samples prepared according to clause 4.7.1 of IEC 60851-5:2008		N/A

IEC 61558-2-16			
Clause	Requirement + Test	Result - Remark	Verdict
	Dielectric strength test: 5,5 kV for reinforced insulation		N/A
	Dielectric strength test: 2,75 kV for basic or supplementary insulation		N/A
BB K.2.3	Flexibility and adherence		N/A
	Claus 5.1 in Test 8 of IEC 60851-3:2009 shall be used		N/A
	Test samples prepared according to clause 5.1.1.4 of IEC 60851-3:2009		N/A
	Dielectric strength test: 5,5 kV for reinforced insulation		N/A
	Dielectric strength test: 2,75 kV for basic or supplementary insulation		N/A
	Mandrel diameter according table K.1		N/A
	The tension to the wire during winding on mandrel is 118 N/mm ² (118 MPa)		N/A
BB.K.2.4	Heat shock		N/A
	Test samples prepared according to 3.1.1 (in Test 9) of IEC 60851-6:1996		N/A
	<ul style="list-style-type: none"> high voltage test immediately after this test 		N/A
	<ul style="list-style-type: none"> Dielectric strength test: 5,5 kV for reinforced insulation 		N/A
	<ul style="list-style-type: none"> Dielectric strength test: 2,75 kV for basic or supplementary insulation 		N/A
BB.K.2.5	Retention of dielectric strength after bending (test as specified under test 13 of 4.6.1 c) of IEC 60 851-5)		N/A
	<ul style="list-style-type: none"> high voltage test immediately after this test 		N/A
	<ul style="list-style-type: none"> Dielectric strength test: 5,5 kV for reinforced insulation 		
	<ul style="list-style-type: none"> Dielectric strength test: 2,75 kV for basic or supplementary insulation 		
BB.K.3	Testing during manufacturing		N/A
BB.K.3.1	General Tests as subjected in K.3.2 and K.3.3		N/A
BB K.3.2	Routine test		N/A
	<ul style="list-style-type: none"> Dielectric strength test: 4,2 kV for reinforced insulation 		N/A
	<ul style="list-style-type: none"> Dielectric strength test: 2,1 kV for basic or supplementary insulation 		N/A
BB K.3.3	Sampling test		N/A

IEC 61558-2-16			
Clause	Requirement + Test	Result - Remark	Verdict
BB K.3.3.1	Solid circular winding wires and stranded winding wires		N/A
	Test with a twisted pair, prepared according clause 4.4.1 of IEC 60851-5:2008		N/A
	<ul style="list-style-type: none"> Dielectric strength test: 6 kV for reinforced insulation 		N/A
	<ul style="list-style-type: none"> Dielectric strength test: 3 kV for basic or supplementary insulation 		N/A
BB K.3.3.2	Square rectangular wire		N/A
	Samples prepared according to clause 4.7.1 of IEC 60851-5:2008		N/A
	<ul style="list-style-type: none"> Dielectric strength test: 5,5 kV for reinforced insulation 		N/A
	<ul style="list-style-type: none"> Dielectric strength test: 3 kV for basic or supplementary insulation 		N/A
BB.U	ANNEX U – INFORMATIVE – OPTIONAL TW – MARKING FOR TRANSFORMERS		N/A
V	ANNEX V, SYMBOLS TO BE USED FOR THERMAL CUT-OUTS		N/A

BB.26.2 TEST A	TABLE: CREEPAGE DISTANCES AND CLEARANCES AND DISTANCES THROUGH INSULATION					N/A
	Test with three special prepared specimens with uninsulated wires, without potting or impregnation					
	cycles with 2 x working voltage between pri / sec	68 h at the temperature acc. Cl. 14 (min. 85 °C)	1 hour 25 °C	2 hour 0 °C	1 hour 25 °C	
1.						
2.						
3.						
4.						
5.						
6.						
7.						
8.						
9.						
10.						

BB.26.2 TEST B	TABLE: CREEPAGE DISTANCES AND CLEARANCES AND DISTANCES THROUGH INSULATION					N/A
	Test with three specially prepared specimens with potted – P1 values are required					

IEC 61558-2-16						
Clause	Requirement + Test				Result - Remark	Verdict
	cycles with 2 x working voltage between pri / sec	68 h at the temperature acc. Cl. 14 (min. 85 °C)	1 hour 25 °C	2 hour 0 °C	1 hour 25 °C	
1.						
2.						
3.						
4.						
5.						
6.						
7.						
8.						
9.						
10.						

BB.26.2 TEST C	TABLE: CREEPAGE DISTANCES AND CLEARANCES AND DISTANCES THROUGH INSULATION					N/A
	Test with three specially prepared specimens with potting (only dti is required)					
	cycles with 2 x working voltage between pri / sec	68 h at the temperature acc. Cl. 14 (min. 85 °C)	1 hour 25 °C	2 hour 0 °C	1 hour 25 °C	
1.						
2.						
3.						
4.						
5.						
6.						
7.						
8.						
9.						
10.						

BB.26.107 61558-2- 16/A1	TABLE: CREEPAGE DISTANCES AND CLEARANCES AND DISTANCES THROUGH INSULATION					N/A
	Test for transformers, use FIW-wire					
	cycles with 2 x working voltage between pri / sec	68 h at the temperature acc. Cl. 14 (min. 85 °C)	1 hour 25 °C	2 hour 0 °C	1 hour 25 °C	
1.						

IEC 61558-2-16					
Clause	Requirement + Test			Result - Remark	Verdict
2.					
3.					
4.					
5.					
6.					
7.					
8.					
9.					
10.					

BB 18.2	TABLE: insulation resistance measurements			N/A
Insulation resistance R between:		R (MΩ)	Required R (MΩ)	
Supplementary information:				

BB 18.3	TABLE: Dielectric Strength			N/A
Test voltage applied between:		Test potential applied (V)	Breakdown / flashover (Yes/No)	
Supplementary information:				

BB 26	TABLE: Clearance And Creepage Distance Measurements						N/A
clearance cl and creepage distance dcr at/of:	Up (V)	U r.m.s. (V)	Required cl (mm)	cl (mm)	required dcr (mm)	dcr (mm)	
Supplementary information:							

BB 26	TABLE: Distance Through Insulation Measurements				N/A
Distance through insulation di at/of:	U r.m.s. (V)	Test voltage (V)	Required di (mm)	di (mm)	
Supplementary information:					

Attachment No. 1

EN 61558-2-16:2009+A1:2013

Clause	Requirement + Test	Result - Remark	Verdict		
Annex ZA	Normative references to international publications with their corresponding European publications		P		
	Addition to Annex ZA of EN 61558-1:				
	<u>Publication</u>	<u>Year</u>	<u>Title</u>	<u>EN/HD</u>	<u>Year</u>
	IEC 60227	Series	Polyvinyl chloride insulated cables of rated voltages up to and including 450/750 V	– ¹⁾	–
	IEC 60364-4-41 (mod)	– ²⁾	Low-voltage electrical installations - Part 4-41: Protection for safety - Protection against electric shock	HD 60364-4-41 + corr. July	2007 ³⁾ 2007
	IEC 60601-1	– ²⁾	Medical electrical equipment - Part 1: General requirements for basic safety and essential performance	EN 60601-1	2006 ³⁾
	IEC 60664-4	2005	Insulation coordination for equipment within low-voltage systems - Part 4: Consideration of high-frequency voltage stress	EN 60664-4 + corr. October	2006 2006
	IEC 60950-1 (mod)	– ²⁾	Information technology equipment - Safety - Part 1: General requirements	EN 60950-1 + A11	2006 ³⁾ 2009
	IEC 61010-1	– ²⁾	Safety requirements for electrical equipment for measurement, control and laboratory use - Part 1: General requirements	EN 61010-1 + corr. June	2001 ³⁾ 2002
	IEC 61204-7	2006	Low voltage power supplies, d.c. output - Part 7: Safety requirements	EN 61204-7 + A11	2006 2009
	IEC 61347 (mod)	Series	Lamp controlgear	EN 61347	Series
	IEC 61558-1	2005	Safety of power transformers, power supplies, reactors and similar products - Part 1: General requirements and tests	EN 61558-1 + corr. August	2005 2006
	IEC 61558-2-1	– ²⁾	Safety of power transformers, power supplies, reactors and similar products - Part 2-1: Particular requirements and tests for separating transformers and power supplies incorporating separating transformers for general applications	EN 61558-2-1	2007 ³⁾
	IEC 61558-2-4	– ²⁾	Safety of transformers, reactors, power supply units and similar products for supply voltages up to 1 100 V - Part 2-4: Particular requirements and tests for isolating transformers and power supply units incorporating isolating transformers	EN 61558-2-4	2009 ³⁾
	IEC 61558-2-6	– ²⁾	Safety of transformers, reactors, power supply units and similar products for supply voltages up to 1 100 V - Part 2-6: Particular requirements and tests for safety isolating transformers and power supply units incorporating safety isolating transformers	EN 61558-2-6	2009 ³⁾
	IEC 61558-2-13	– ²⁾	Safety of transformers, reactors, power supply units and similar products for supply voltages up to 1 100 V - Part 2-13: Particular requirements and tests for auto transformers and power supply units incorporating auto transformers	EN 61558-2-13	2009 ³⁾
	IEC 62040	Series	Uninterruptible Power Systems (UPS)	EN 62040	Series

Attachment No. 1

EN 61558-2-16:2009+A1:2013

Clause	Requirement + Test	Result - Remark	Verdict																														
Annex ZA	<p style="text-align: center;">Annex ZA (normative)</p> <p style="text-align: center;">Normative references to international publications with their corresponding European publications</p> <p>The following documents, in whole or in part, are normatively referenced in this document and are indispensable for its application. For dated references, only the edition cited applies. For undated references, the latest edition of the referenced document (including any amendments) applies.</p> <p>NOTE When an international publication has been modified by common modifications, indicated by (mod), the relevant EN/HD applies.</p> <p><i>Add, to the existing list of references, the following new references:</i></p> <table border="1" data-bbox="416 786 1353 1279"> <thead> <tr> <th><u>Publication</u></th> <th><u>Year</u></th> <th><u>Title</u></th> <th><u>EN/HD</u></th> <th><u>Year</u></th> </tr> </thead> <tbody> <tr> <td>IEC 60317-0-7</td> <td>2012</td> <td>Specifications for particular types of winding wires - Part 0-7: General requirements - Fully insulated (FIW) zero-defect enamelled round copper wire with nominal conductor diameter of 0,040 mm to 1,600 mm</td> <td>EN 60317-0-7</td> <td>2012</td> </tr> <tr> <td>IEC 60317-43</td> <td>-</td> <td>Specifications for particular types of winding wires - Part 43: Aromatic polyimide tape wrapped round copper wire, class 240</td> <td>EN 60317-43</td> <td>-</td> </tr> <tr> <td>IEC 60317-56</td> <td>-</td> <td>Specifications for particular types of winding wires - Part 56: Solderable fully insulated (FIW) zero-defect polyurethane enamelled round copper wire with nominal conductor diameter of 0,040 mm to 1,600 mm, class 180</td> <td>EN 60317-56</td> <td>-</td> </tr> <tr> <td>IEC 60851-3</td> <td>2009</td> <td>Winding wires - Test methods - Part 3: Mechanical properties</td> <td>EN 60851-3</td> <td>2009</td> </tr> <tr> <td>IEC 60851-5</td> <td>2008</td> <td>Winding wires - Test methods - Part 5: Electrical properties</td> <td>EN 60851-5</td> <td>2008</td> </tr> </tbody> </table>		<u>Publication</u>	<u>Year</u>	<u>Title</u>	<u>EN/HD</u>	<u>Year</u>	IEC 60317-0-7	2012	Specifications for particular types of winding wires - Part 0-7: General requirements - Fully insulated (FIW) zero-defect enamelled round copper wire with nominal conductor diameter of 0,040 mm to 1,600 mm	EN 60317-0-7	2012	IEC 60317-43	-	Specifications for particular types of winding wires - Part 43: Aromatic polyimide tape wrapped round copper wire, class 240	EN 60317-43	-	IEC 60317-56	-	Specifications for particular types of winding wires - Part 56: Solderable fully insulated (FIW) zero-defect polyurethane enamelled round copper wire with nominal conductor diameter of 0,040 mm to 1,600 mm, class 180	EN 60317-56	-	IEC 60851-3	2009	Winding wires - Test methods - Part 3: Mechanical properties	EN 60851-3	2009	IEC 60851-5	2008	Winding wires - Test methods - Part 5: Electrical properties	EN 60851-5	2008	P
<u>Publication</u>	<u>Year</u>	<u>Title</u>	<u>EN/HD</u>	<u>Year</u>																													
IEC 60317-0-7	2012	Specifications for particular types of winding wires - Part 0-7: General requirements - Fully insulated (FIW) zero-defect enamelled round copper wire with nominal conductor diameter of 0,040 mm to 1,600 mm	EN 60317-0-7	2012																													
IEC 60317-43	-	Specifications for particular types of winding wires - Part 43: Aromatic polyimide tape wrapped round copper wire, class 240	EN 60317-43	-																													
IEC 60317-56	-	Specifications for particular types of winding wires - Part 56: Solderable fully insulated (FIW) zero-defect polyurethane enamelled round copper wire with nominal conductor diameter of 0,040 mm to 1,600 mm, class 180	EN 60317-56	-																													
IEC 60851-3	2009	Winding wires - Test methods - Part 3: Mechanical properties	EN 60851-3	2009																													
IEC 60851-5	2008	Winding wires - Test methods - Part 5: Electrical properties	EN 60851-5	2008																													

Attachment No. 2

Clause	Requirement + Test	Result - Remark	Verdict
--------	--------------------	-----------------	---------

ATTACHMENT TO TEST REPORT Applicable for all standards applied for testing of plug-in power supplies Germany NATIONAL DIFFERENCES GS Scheme			
Differences according to.....:		all standards applied for testing of plug-in power supplies e.g. EN 60065, EN 60335, EN 60601, EN 60950-1, EN 61010, EN 61558, EN 60598, EN 61029, EN 60745, VDE 0620	
Attachment Form No.....:		Germany_ND_GS_Scheme_EK1 557-13	
Attachment Originator		TÜV SÜD Product Service GmbH	
Master Attachment.....:		Date 2013-07	

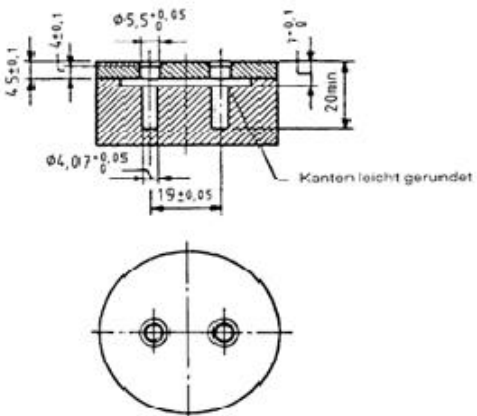
Special national conditions			
Germany GS Scheme according EK1 557-13			
	<p>The moulded plug of plug-in power supplies will be considered as component and will be generally evaluated in Germany according to DIN VDE 0620-1:2010 respectively DIN VDE 0620-1:2013 and DIN VDE 0620-2-1:2013. After the test according to DIN VDE 0620-2-1:2013, sub-clause 24.2, the plug be shall still pass the test according to DIN VDE 0620-101:1992 clause 7, figure 2 "Gauge for interchangeability" It should be possible to insert the plug without applying an excessive force such that the end surface touches the surface of the gauge</p> 	<p>Remark: The complete plug-in power supply is considered as a "plug" and has to be tested in the tumbling barrel</p>	P

Contains

Cover page	1 page
EU plug portion test report	16 pages
UK plug portion test report (3 pins)	34 pages
Total:	51 pages

Attachment No. 4

“EU plug portion test” according to EN 50075:1990

For models: CZH015xxxxxyyEUWH, CZH015xxxxxyyEUWP, CZH015xxxxxyyEUWHL, CZH015xxxxxyyEUWPL, CZH015xxxxxyyEUWHG, CZH015xxxxxyyEUWPG, CZH015xxxxxyyEUWHLG, CZH015xxxxxyyEUWPLG

Clause	Requirement- Test	Result- Remark	Verdict
7	Dimension of plug shall comply with Standard Sheet 1	(See appended table)	P

8	Protection against electric shock		P
8.1	Live parts of the plugs, with the exception of the bare metal pins, should not be accessible. (75N, 60 second in 35°C ambient)		P
8.2	It should not be possible to make connection between a pin of a plug and live socket contact of a socket while the other pin is accessible.		P
8.3	External parts of the plugs made of insulating material.		P

9	Construction		P
9.3	Plugs shall have adequate mechanical strength to withstand the stresses imposed during use.		P
9.4	Pins of plugs shall be locked against rotation and adequately fixed into body of the plug.		P
9.6	Plug shall be shaped in such a way and made of such material that they can easily be withdrawn by hand from the socket outlet		P

13	Mechanical Strength		P
13.1	Compression test, 150N		P
13.2	Tumbling barrel test for adapter After test, the pin shall not turn when a torque of 0.4Nm is applied, first in one direction for 1 min and then in the opposite direction for 1 min.	Tumbling barrel: 1000 times (For models CZH015xxxxxyyEUWH, CZH015xxxxxyyEUWP, CZH015xxxxxyyEUWHL, CZH015xxxxxyyEUWPL); Tumbling barrel: 500 times (For models CZH015xxxxxyyEUWHG, CZH015xxxxxyyEUWPG, CZH015xxxxxyyEUWHLG, CZH015xxxxxyyEUWPLG) (The EK1 557-13 requirement was considered)	P
13.3	Abrasion test on the insulating sleeves		P
13.4	Pin shall not have displaced in body of the plug more than 1mm; force (N)	50N, Pin displaced < 1mm	P

15	Current-carrying parts and connection		P
----	---------------------------------------	--	---

Attachment No. 4

Clause	Requirement- Test	Result- Remark	Verdict
15.2	Electric connection shall be so designed that contact pressure is not transmitted through insulation.		P
15.3	Current-carrying parts		P
	Copper		P
	Alloy containing at least 58% of copper or equivalent	Alloy containing 59.95% of copper	P
	Suitable metals, other than copper or copper alloy		N/A
17	Resistance of insulating material to abnormal heat and fire		P
	Glow-wire test		P
	Parts of insulating material to retain current-carrying parts:750°C		P
	Other parts: 650°C		P

7	Table: Dimension of plug				P
Location	1 st Sample	2 nd Sample	3 rd sample	Limit (mm)	
A	26.46	26.43	26.45	26.1 ± 0.5*1	
B	14.12	14.12	14.10	13.7 ± 0.7*1	
C	35.68	35.67	35.68	35.3 ± 0.7*1	
(see note *1)	18.58	18.56	18.56	≥18	
D	19.22	19.25	19.24	19 ± 0.5	
E	3.96	3.97	3.98	Ø4.0 ± 0.06	
F	3.34	3.33	3.34	Ø3.8 Max.	
F	3.84	3.83	3.83	Ø4.0 Max.*3	
F	3.90	3.89	3.88	4 Max.*3	
G	10.57	10.53	10.56	10-11	
a1	18.40	18.41	18.40	18-19.2*2	
a2	17.75	17.76	17.74	17-18*2	
H	18.58	18.56	18.56	4 Min.	
I	R5.3	R5.4	R5.4	R5-R6	
J	45°	45°	45°	---	
Alternative for end of pins					
K	N/A	N/A	N/A	Ø0.7- Ø1.7	
L	N/A	N/A	N/A	90° Max.	
M	N/A	N/A	N/A	2 Max.	

Note

*1: These dimension shall not exceeded within a distance of 18mm from the engagement face of plug.

*2: a1: in the plane of the engagement face, a2: at the ends of pins.

*3: This dimension maybe increased to 4mm within a distance of 4mm from engagement face of plug.

Remark: see standard sheet 1 for details of location of measurement.

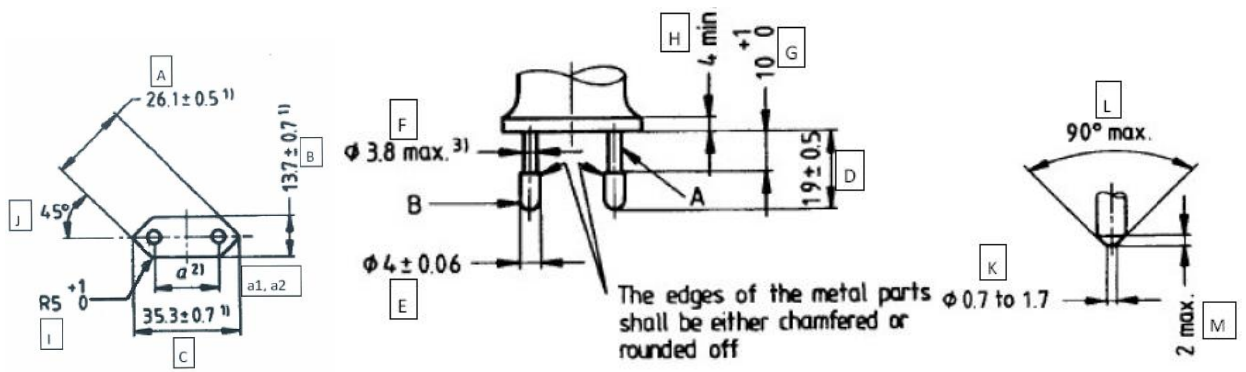

Standard sheet 1

Attachment No. 4

“EU plug portion test” according to EN 50075:1990

For models: CZH015xxxxyyyEUWM, CZH015xxxxyyyEUWF, CZH015xxxxyyyEUWML, CZH015xxxxyyyEUWFL, CZH015xxxxyyyEUWMLG, CZH015xxxxyyyEUWFLG, CZH015050yyyEUUM

Clause	Requirement- Test	Result- Remark	Verdict
7	Dimension of plug shall comply with Standard Sheet 1	(See appended table)	P
8	Protection against electric shock		P
8.1	Live parts of the plugs, with the exception of the bare metal pins, should not be accessible. (75N, 60 second in 35°C ambient)		P
8.2	It should not be possible to make connection between a pin of a plug and live socket contact of a socket while the other pin is accessible.		P
8.3	External parts of the plugs made of insulating material.		P
9	Construction		P
9.3	Plugs shall have adequate mechanical strength to withstand the stresses imposed during use.		P
9.4	Pins of plugs shall be locked against rotation and adequately fixed into body of the plug.		P
9.6	Plug shall be shaped in such a way and made of such material that they can easily be withdrawn by hand from the socket outlet		P
13	Mechanical Strength		P
13.1	Compression test, 150N		P
13.2	Tumbling barrel test for adapter After test, the pin shall not turn when a torque of 0.4Nm is applied, first in one direction for 1 min and then in the opposite direction for 1 min.	Tumbling barrel: 500 times (For models: CZH015xxxxyyyEUWM, CZH015xxxxyyyEUWF, CZH015xxxxyyyEUWML, CZH015xxxxyyyEUWFL, CZH015xxxxyyyEUWMLG, CZH015xxxxyyyEUWFLG, CZH015xxxxyyyEUWMLG, CZH015xxxxyyyEUWFLG); Tumbling barrel: 1000 times (For models: CZH015xxxxyyyEUUM) (The EK1 557-13 requirement was considered)	P
13.3	Abrasion test on the insulating sleeves		P
13.4	Pin shall not have displaced in body of the plug more than 1mm; force (N)	50N, Pin displaced < 1mm	P

Attachment No. 4

Clause	Requirement- Test	Result- Remark	Verdict
15	Current-carrying parts and connection		P
15.2	Electric connection shall be so designed that contact pressure is not transmitted through insulation.		P
15.3	Current-carrying parts		P
	Copper		P
	Alloy containing at least 58% of copper or equivalent	Alloy containing 59.95% of copper	P
	Suitable metals, other than copper or copper alloy		N/A
17	Resistance of insulating material to abnormal heat and fire		P
	Glow-wire test		P
	Parts of insulating material to retain current-carrying parts:750°C		P
	Other parts: 650°C		P

7	Table: Dimension of plug				P
Location	1 st Sample	2 nd Sample	3 rd sample	Limit (mm)	
A	26.35	26.33	26.34	26.1 ± 0.5* ¹	
B	14.03	14.02	14.04	13.7 ± 0.7* ¹	
C	35.56	35.57	35.56	35.3 ± 0.7* ¹	
(see note *1)	18.03	18.03	18.02	≥18	
D	19.22	19.25	19.24	19 ± 0.5	
E	3.99	3.98	4.00	Ø4.0 ± 0.06	
F	3.49	3.47	3.50	Ø3.8 Max.	
F	3.85	3.83	3.83	Ø4.0 Max.* ³	
F	3.94	3.93	3.95	4 Max.* ³	
G	10.47	10.43	10.46	10-11	
a1	18.40	18.41	18.40	18-19.2* ²	
a2	17.45	17.46	17.44	17-18* ²	
H	18.03	18.03	18.02	4 Min.	
I	R5.5	R5.3	R5.4	R5-R6	
J	45°	45°	45°	---	
Alternative for end of pins					
K	N/A	N/A	N/A	Ø0.7- Ø1.7	
L	N/A	N/A	N/A	90° Max.	
M	N/A	N/A	N/A	2 Max.	

Note

*1: These dimension shall not exceeded within a distance of 18mm from the engagement face of plug.

*2: a1: in the plane of the engagement face, a2: at the ends of pins.

*3: This dimension maybe increased to 4mm within a distance of 4mm from engagement face of plug.

Remark: see standard sheet 1 for details of location of measurement.

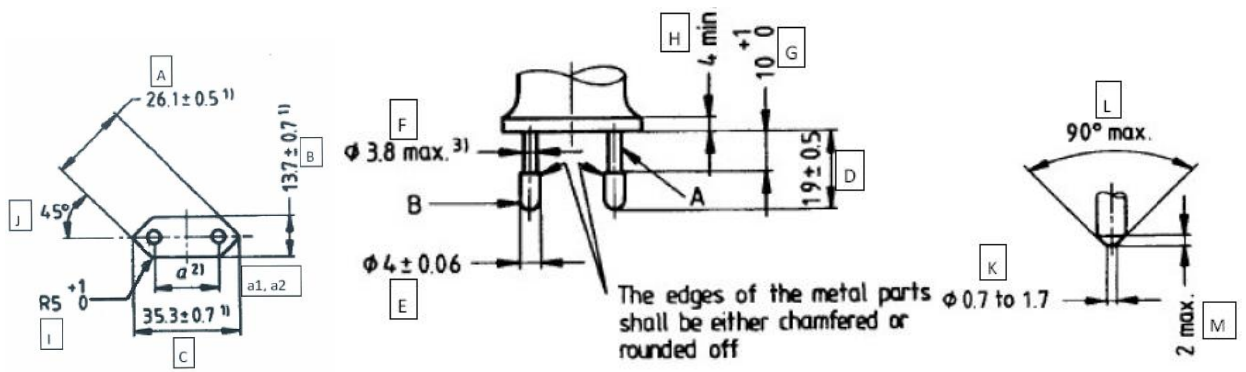

Standard sheet 1

Attachment No. 4

“EU plug portion test” according to EN 50075:1990

For models: CZH015xxxxyyTRWM, CZH015xxxxyyTRWF, CZH015xxxxyyTRWML, CZH015xxxxyyTRWFL (with detachable EU plug)

Clause	Requirement- Test	Result- Remark	Verdict
7	Dimension of plug shall comply with Standard Sheet 1	(See appended table)	P

8	Protection against electric shock		P
8.1	Live parts of the plugs, with the exception of the bare metal pins, should not be accessible. (75N, 60 second in 35°C ambient)		P
8.2	It should not be possible to make connection between a pin of a plug and live socket contact of a socket while the other pin is accessible.		P
8.3	External parts of the plugs made of insulating material.		P

9	Construction		P
9.3	Plugs shall have adequate mechanical strength to withstand the stresses imposed during use.		P
9.4	Pins of plugs shall be locked against rotation and adequately fixed into body of the plug.		P
9.6	Plug shall be shaped in such a way and made of such material that they can easily be withdrawn by hand from the socket outlet		P

13	Mechanical Strength		P
13.1	Compression test, 150N		P
13.2	Tumbling barrel test for adapter After test, the pin shall not turn when a torque of 0.4Nm is applied, first in one direction for 1 min and then in the opposite direction for 1 min.	Tumbling barrel: 500 times (The EK1 557-13 requirement was considered)	P
13.3	Abrasion test on the insulating sleeves		P
13.4	Pin shall not have displaced in body of the plug more than 1mm; force (N)	50N, Pin displaced < 1mm	P

15	Current-carrying parts and connection		P
15.2	Electric connection shall be so designed that contact pressure is not transmitted through insulation.		P
15.3	Current-carrying parts		P
	Copper		P
	Alloy containing at least 58% of copper or equivalent	Alloy containing 59.95% of copper	P
	Suitable metals, other than copper or copper alloy		N/A

Attachment No. 4

Clause	Requirement- Test	Result- Remark	Verdict
17	Resistance of insulating material to abnormal heat and fire		P
	Glow-wire test		P
	Parts of insulating material to retain current-carrying parts:750°C		P
	Other parts: 650°C		P

7	Table: Dimension of plug				P
Location	1 st Sample	2 nd Sample	3 rd sample	Limit (mm)	
A	26.50	26.53	26.55	26.1 ± 0.5*1	
B	14.32	14.32	14.30	13.7 ± 0.7*1	
C	35.88	35.87	35.88	35.3 ± 0.7*1	
(see note *1)	18.08	18.06	18.06	≥18	
D	19.22	19.23	19.24	19 ± 0.5	
E	3.96	3.95	3.96	Ø4.0 ± 0.06	
F	3.40	3.43	3.44	Ø3.8 Max.	
F	3.80	3.78	3.80	Ø4.0 Max.*3	
F	3.92	3.89	3.94	4 Max.*3	
G	10.57	10.60	10.56	10-11	
a1	18.50	18.51	18.50	18-19.2*2	
a2	17.75	17.76	17.74	17-18*2	
H	18.08	18.06	18.06	4 Min.	
I	R5.7	R5.5	R5.4	R5-R6	
J	45°	45°	45°	---	
Alternative for end of pins					
K	N/A	N/A	N/A	Ø0.7- Ø1.7	
L	N/A	N/A	N/A	90° Max.	
M	N/A	N/A	N/A	2 Max.	

Note

*1: These dimension shall not exceeded within a distance of 18mm from the engagement face of plug.

*2: a1: in the plane of the engagement face, a2: at the ends of pins.

*3: This dimension maybe increased to 4mm within a distance of 4mm from engagement face of plug.

Remark: see standard sheet 1 for details of location of measurement.

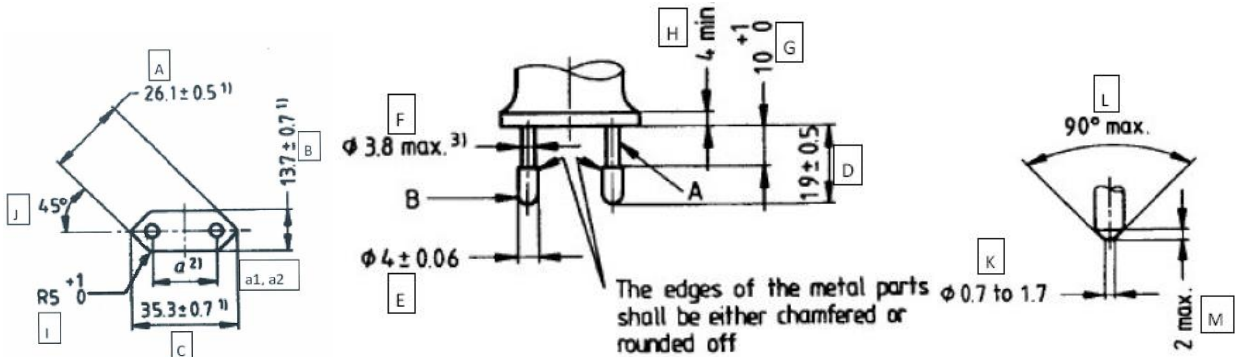

Standard sheet 1

Attachment No. 4

“EU plug portion test” according to EN 50075:1990

For models: CZH015xxxxyyEUWAa

Clause	Requirement- Test	Result- Remark	Verdict
7	Dimension of plug shall comply with Standard Sheet 1	(See appended table)	P

8	Protection against electric shock		P
8.1	Live parts of the plugs, with the exception of the bare metal pins, should not be accessible. (75N, 60 second in 35°C ambient)		P
8.2	It should not be possible to make connection between a pin of a plug and live socket contact of a socket while the other pin is accessible.		P
8.3	External parts of the plugs made of insulating material.		P

9	Construction		P
9.3	Plugs shall have adequate mechanical strength to withstand the stresses imposed during use.		P
9.4	Pins of plugs shall be locked against rotation and adequately fixed into body of the plug.		P
9.6	Plug shall be shaped in such a way and made of such material that they can easily be withdrawn by hand from the socket outlet		P

13	Mechanical Strength		P
13.1	Compression test, 150N		P
13.2	Tumbling barrel test for adapter After test, the pin shall not turn when a torque of 0.4Nm is applied, first in one direction for 1 min and then in the opposite direction for 1 min.	Tumbling barrel: 1000 times (The EK1 557-13 requirement was considered)	P
13.3	Abrasion test on the insulating sleeves		P
13.4	Pin shall not have displaced in body of the plug more than 1mm; force (N)	50N, Pin displaced 0.2mm	P

15	Current-carrying parts and connection		P
15.2	Electric connection shall be so designed that contact pressure is not transmitted through insulation.		P
15.3	Current-carrying parts		P
	Copper		P
	Alloy containing at least 58% of copper or equivalent	Alloy containing 59.95% of copper	P
	Suitable metals, other than copper or copper alloy		N/A

Attachment No. 4

Clause	Requirement- Test	Result- Remark	Verdict
17	Resistance of insulating material to abnormal heat and fire		P
	Glow-wire test		P
	Parts of insulating material to retain current-carrying parts:750°C		P
	Other parts: 650°C		P

7	Table: Dimension of plug				P
Location	1 st Sample	2 nd Sample	3 rd sample	Limit (mm)	
A	26.35	26.38	26.36	$26.1 \pm 0.5^{*1}$	
B	14.18	14.19	14.17	$13.7 \pm 0.7^{*1}$	
C	35.88	35.90	35.88	$35.3 \pm 0.7^{*1}$	
(see note *1)	18.09	18.11	18.11	≥ 18	
D	18.93	18.95	18.93	19 ± 0.5	
E	3.97	3.97	3.98	$\varnothing 4.0 \pm 0.06$	
F	3.57	3.58	3.58	$\varnothing 3.8$ Max.	
F	3.83	3.85	3.85	$\varnothing 4.0$ Max. ^{*3}	
F	3.78	3.80	3.78	4 Max. ^{*3}	
G	10.54	10.54	10.56	10-11	
a1	18.24	18.24	18.26	18-19.2 ^{*2}	
a2	17.20	17.21	17.20	17-18 ^{*2}	
H	18.09	18.11	18.11	4 Min.	
I	5.66	5.60	5.62	R5-R6	
J	45°	45°	45°	---	
Alternative for end of pins					
K	N/A	N/A	N/A	$\varnothing 0.7 - \varnothing 1.7$	
L	N/A	N/A	N/A	90° Max.	
M	N/A	N/A	N/A	2 Max.	

Note

*1: These dimension shall not exceeded within a distance of 18mm from the engagement face of plug.

*2: a1: in the plane of the engagement face, a2: at the ends of pins.

*3: This dimension maybe increased to 4mm within a distance of 4mm from engagement face of plug.

Remark: see standard sheet 1 for details of location of measurement.

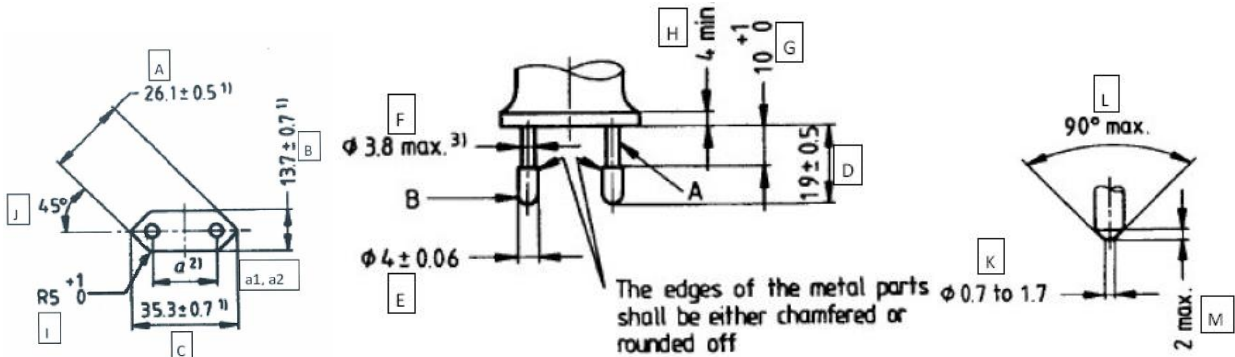

Standard sheet 1

Attachment No. 4

“EU plug portion test” according to EN 50075:1990

For models: CZH015050yyyEUUGa

Clause	Requirement- Test	Result- Remark	Verdict
7	Dimension of plug shall comply with Standard Sheet 1	(See appended table)	P

8	Protection against electric shock		P
8.1	Live parts of the plugs, with the exception of the bare metal pins, should not be accessible. (75N, 60 second in 35°C ambient)		P
8.2	It should not be possible to make connection between a pin of a plug and live socket contact of a socket while the other pin is accessible.		P
8.3	External parts of the plugs made of insulating material.		P

9	Construction		P
9.3	Plugs shall have adequate mechanical strength to withstand the stresses imposed during use.		P
9.4	Pins of plugs shall be locked against rotation and adequately fixed into body of the plug.		P
9.6	Plug shall be shaped in such a way and made of such material that they can easily be withdrawn by hand from the socket outlet		P

13	Mechanical Strength		P
13.1	Compression test, 150N		P
13.2	Tumbling barrel test for adapter After test, the pin shall not turn when a torque of 0.4Nm is applied, first in one direction for 1 min and then in the opposite direction for 1 min.	Tumbling barrel: 1000 times (The EK1 557-13 requirement was considered)	P
13.3	Abrasion test on the insulating sleeves		P
13.4	Pin shall not have displaced in body of the plug more than 1mm; force (N)	50N, Pin displaced 0.3mm	P

15	Current-carrying parts and connection		P
15.2	Electric connection shall be so designed that contact pressure is not transmitted through insulation.		P
15.3	Current-carrying parts		P
	Copper		P
	Alloy containing at least 58% of copper or equivalent	Alloy containing 59.95% of copper	P
	Suitable metals, other than copper or copper alloy		N/A

Attachment No. 4

Clause	Requirement- Test	Result- Remark	Verdict
17	Resistance of insulating material to abnormal heat and fire		P
	Glow-wire test		P
	Parts of insulating material to retain current-carrying parts:750°C		P
	Other parts: 650°C		P

7	Table: Dimension of plug				P
Location	1 st Sample	2 nd Sample	3 rd sample	Limit (mm)	
A	26.23	26.20	26.21	26.1 ± 0.5 ^{*1}	
B	14.15	14.14	14.14	13.7 ± 0.7 ^{*1}	
C	35.80	35.82	35.82	35.3 ± 0.7 ^{*1}	
(see note *1)	18.20	18.17	18.18	≥18	
D	18.72	18.70	18.70	19 ± 0.5	
E	3.99	3.97	3.98	Ø4.0 ± 0.06	
F	3.44	3.43	3.44	Ø3.8 Max.	
F	3.80	3.81	3.80	Ø4.0 Max. ^{*3}	
F	3.82	3.82	3.81	4 Max. ^{*3}	
G	10.46	10.45	10.48	10-11	
a1	18.64	18.61	18.62	18-19.2 ^{*2}	
a2	17.67	17.64	17.65	17-18 ^{*2}	
H	18.20	18.17	18.18	4 Min.	
I	5.28	5.40	5.34	R5-R6	
J	45°	45°	45°	---	
Alternative for end of pins					
K	N/A	N/A	N/A	Ø0.7- Ø1.7	
L	N/A	N/A	N/A	90° Max.	
M	N/A	N/A	N/A	2 Max.	

Note

*1: These dimension shall not exceeded within a distance of 18mm from the engagement face of plug.

*2: a1: in the plane of the engagement face, a2: at the ends of pins.

*3: This dimension maybe increased to 4mm within a distance of 4mm from engagement face of plug.

Remark: see standard sheet 1 for details of location of measurement.

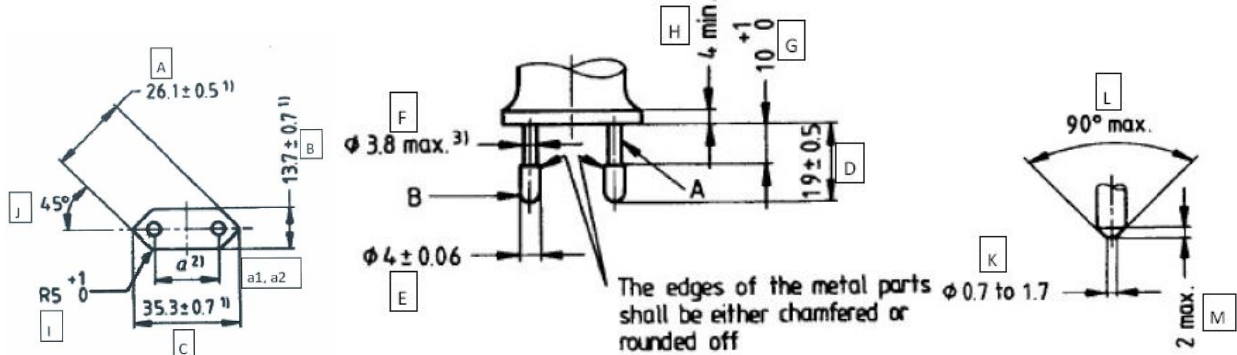

Standard sheet 1

Attachment No. 4

“EU plug portion test” according to EN 50075:1990

For models: CZH015xxxxyyyEUWQ, CZH015xxxxyyyEUWQG, CZH015xxxxyyyEUWQL, CZH015xxxxyyyEUWQLG

Clause	Requirement- Test	Result- Remark	Verdict
7	Dimension of plug shall comply with Standard Sheet 1	(See appended table)	P

8	Protection against electric shock		P
8.1	Live parts of the plugs, with the exception of the bare metal pins, should not be accessible. (75N, 60 second in 35°C ambient)		P
8.2	It should not be possible to make connection between a pin of a plug and live socket contact of a socket while the other pin is accessible.		P
8.3	External parts of the plugs made of insulating material.		P

9	Construction		P
9.3	Plugs shall have adequate mechanical strength to withstand the stresses imposed during use.		P
9.4	Pins of plugs shall be locked against rotation and adequately fixed into body of the plug.		P
9.6	Plug shall be shaped in such a way and made of such material that they can easily be withdrawn by hand from the socket outlet		P

13	Mechanical Strength		P
13.1	Compression test, 150N		P
13.2	Tumbling barrel test for adapter After test, the pin shall not turn when a torque of 0.4Nm is applied, first in one direction for 1 min and then in the opposite direction for 1 min.	Tumbling barrel: 1000 times (For models CZH015xxxxyyyEUWQ, CZH015xxxxyyyEUWQL) Tumbling barrel: 1000 times (For models CZH015xxxxyyyEUWQG, CZH015xxxxyyyEUWQLG) (The EK1 557-13 requirement was considered)	P
13.3	Abrasion test on the insulating sleeves		P
13.4	Pin shall not have displaced in body of the plug more than 1mm; force (N)	50N, Pin displaced 0.3mm	P

15	Current-carrying parts and connection		P
15.2	Electric connection shall be so designed that contact pressure is not transmitted through insulation.		P
15.3	Current-carrying parts		P

Attachment No. 4

Clause	Requirement- Test	Result- Remark	Verdict
	Copper		P
	Alloy containing at least 58% of copper or equivalent	Alloy containing 59.95% of copper	P
	Suitable metals, other than copper or copper alloy		N/A
17	Resistance of insulating material to abnormal heat and fire		P
	Glow-wire test		P
	Parts of insulating material to retain current-carrying parts:750°C		P
	Other parts: 650°C		P

7	Table: Dimension of plug				P
Location	1 st Sample	2 nd Sample	3 rd sample	Limit (mm)	
A	26.42	26.44	26.44	26.1 ± 0.5*1	
B	14.16	14.15	14.16	13.7 ± 0.7*1	
C	35.62	35.64	35.63	35.3 ± 0.7*1	
(see note *1)	18.54	18.56	18.54	≥18	
D	18.99	19.01	19.02	19 ± 0.5	
E	3.99	3.97	3.97	Ø4.0 ± 0.06	
F	3.59	3.59	3.60	Ø3.8 Max.	
F	3.76	3.77	3.75	Ø4.0 Max.*3	
F	3.87	3.86	3.88	4 Max.*3	
G	10.40	10.40	10.42	10-11	
a1	18.43	18.42	18.42	18-19.2*2	
a2	17.52	17.54	17.54	17-18*2	
H	18.54	18.56	18.54	4 Min.	
I	5.36	5.44	5.38	R5-R6	
J	45°	45°	45°	---	
Alternative for end of pins					
K	N/A	N/A	N/A	Ø0.7- Ø1.7	
L	N/A	N/A	N/A	90° Max.	
M	N/A	N/A	N/A	2 Max.	

Note

*1: These dimension shall not exceeded within a distance of 18mm from the engagement face of plug.

*2: a1: in the plane of the engagement face, a2: at the ends of pins.

*3: This dimension maybe increased to 4mm within a distance of 4mm from engagement face of plug.

Remark: see standard sheet 1 for details of location of measurement.

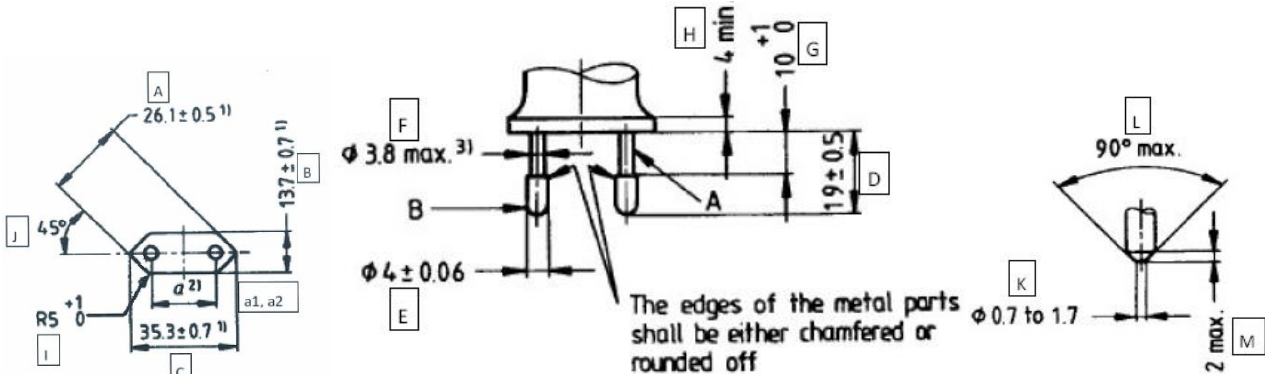

Standard sheet 1

Attachment No. 4

“EU plug portion test” according to EN 50075:1990

For models: CZH015xxxxyyTRWQ, CZH015xxxxyyTRWQL

Clause	Requirement- Test	Result- Remark	Verdict
7	Dimension of plug shall comply with Standard Sheet 1	(See appended table)	P

8	Protection against electric shock		P
8.1	Live parts of the plugs, with the exception of the bare metal pins, should not be accessible. (75N, 60 second in 35°C ambient)		P
8.2	It should not be possible to make connection between a pin of a plug and live socket contact of a socket while the other pin is accessible.		P
8.3	External parts of the plugs made of insulating material.		P

9	Construction		P
9.3	Plugs shall have adequate mechanical strength to withstand the stresses imposed during use.		P
9.4	Pins of plugs shall be locked against rotation and adequately fixed into body of the plug.		P
9.6	Plug shall be shaped in such a way and made of such material that they can easily be withdrawn by hand from the socket outlet		P

13	Mechanical Strength		P
13.1	Compression test, 150N		P
13.2	Tumbling barrel test for adapter After test, the pin shall not turn when a torque of 0.4Nm is applied, first in one direction for 1 min and then in the opposite direction for 1 min.	Tumbling barrel: 1000 times (The EK1 557-13 requirement was considered)	P
13.3	Abrasion test on the insulating sleeves		P
13.4	Pin shall not have displaced in body of the plug more than 1mm; force (N)	50N, Pin displaced 0.3mm	P

15	Current-carrying parts and connection		P
15.2	Electric connection shall be so designed that contact pressure is not transmitted through insulation.		P
15.3	Current-carrying parts		P
	Copper		P
	Alloy containing at least 58% of copper or equivalent	Alloy containing 59.95% of copper	P
	Suitable metals, other than copper or copper alloy		N/A

Attachment No. 4

Clause	Requirement- Test	Result- Remark	Verdict
17	Resistance of insulating material to abnormal heat and fire		P
	Glow-wire test		P
	Parts of insulating material to retain current-carrying parts:750°C		P
	Other parts: 650°C		P

7	Table: Dimension of plug				P
Location	1 st Sample	2 nd Sample	3 rd sample	Limit (mm)	
A	26.44	26.42	26.46	26.1 ± 0.5*1	
B	14.17	14.16	14.14	13.7 ± 0.7*1	
C	35.65	35.63	35.62	35.3 ± 0.7*1	
(see note *1)	18.56	18.57	18.56	≥18	
D	18.98	19.00	19.01	19 ± 0.5	
E	4.01	3.99	3.98	Ø4.0 ± 0.06	
F	3.56	3.57	3.58	Ø3.8 Max.	
F	3.75	3.76	3.74	Ø4.0 Max.*3	
F	3.86	3.87	3.87	4 Max.*3	
G	10.56	10.57	10.56	10-11	
a1	18.46	18.45	18.44	18-19.2*2	
a2	17.54	17.56	17.55	17-18*2	
H	18.56	18.57	18.56	4 Min.	
I	5.36	5.40	5.37	R5-R6	
J	45°	45°	45°	---	
Alternative for end of pins					
K	N/A	N/A	N/A	Ø0.7- Ø1.7	
L	N/A	N/A	N/A	90° Max.	
M	N/A	N/A	N/A </td <td colspan="2">2 Max.</td>	2 Max.	

Note

*1: These dimension shall not exceeded within a distance of 18mm from the engagement face of plug.

*2: a1: in the plane of the engagement face, a2: at the ends of pins.

*3: This dimension maybe increased to 4mm within a distance of 4mm from engagement face of plug.

Remark: see standard sheet 1 for details of location of measurement.

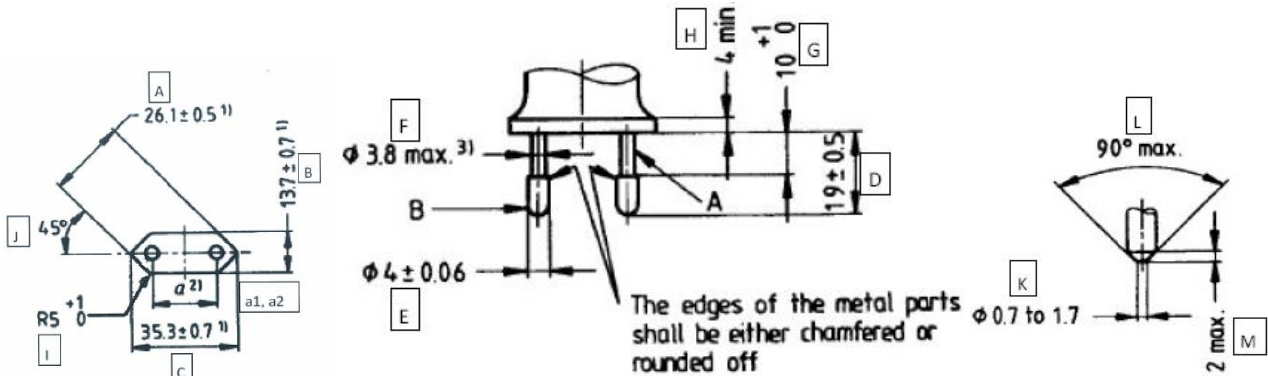

Standard sheet 1

Attachment No. 4

“UK plug portion test” according to BS 1363-1:2016+A1:2018

For models: CZH015xxxxyyBSWH, CZH015xxxxyyBSWP, CZH015xxxxyyBSWHL, CZH015xxxxyyBSWPL, CZH015xxxxyyBSWHG, CZH015xxxxyyBSWPG, CZH015xxxxyyBSWHLG, CZH015xxxxyyBSWPLG

BS 1363-1:2016+A1:2018			
Clause	Requirement – Test	Result – Remarks	Verdict
12.1	Disposition of pins		P
12.2	Dimensions	(See appended table)	P
12.2.1	Gauging test according to figure 5, the plug portion shall enter the gauge fully with a force less than 10N	Applied force: 7N	P
	In the case of adaptors with ISODs, the test given in 13.8 of BS 1363-2:2016 shall be applied and the maximum withdrawal force from a socket-outlet conforming to BS 1363-2:2016 shall not exceed 36N	Applied force: 13N	P
12.3	Distance of pins from periphery	Measured distance: min. 9.98mm	P
12.7	Plugs shall be so designed and constructed that they cannot readily be deformed to allow access to live parts		P
12.7.1	A force of 30N is applied to the accessible surface, the probe shall not be possible to touch live parts		P
12.9	Construction of pins		P
12.9.1	All exposed surfaces of the adaptor plug pins shall be smooth and free from burrs or sharp edges and other irregularities.		P
12.9.2	Those surfaces of the non-solid plug pins which are visible when the plug is correctly assembled shall be free of apertures.		N/A
12.9.3	All seams and joints of non-solid pins shall be closed over their entire length.		P
12.9.3.1	Conformity shall be checked by inspection and in case of doubt by the following test. Push a steel test probe of 0.2 mm diameter into all seams and joints. Check that the test probe does not enter into any seam or joint to a depth greater than the thickness of the material from which the plug pin is formed.		P
12.9.4.1	For solid pins, applying a force 1100N on the pin according to figure 32.		P

Attachment No. 4

BS 1363-1:2016+A1:2018			
Clause	Requirement – Test	Result – Remarks	Verdict
12.9.4.2	For non-solid pins, conformity shall be checked by the following test. 1) Applying a force 800N on the pin according to Figure 32. 50 times without impact. 2) Separate specimens applying a force 1100N on the pin according to Figure 32.		N/A
12.9.4.3	For ISOD, applying a force 400N on the pin according to figure 32.		P
12.9.5	Plugs with nickel plated brass pins, non-solid pins and/or ISODs shall not cause excessive wear to socket contacts or shutters of socket-outlets in accordance with BS 1363-2:2016. For plugs with nickel plated brass pins and/or non-solid pins conformity shall be checked by 12.9.5.1. For plugs with ISODs conformity shall be checked by 12.9.5.2.		P
12.9.5.1	Adaptors with nickel plated brass pins and/or non-solid pins shall not cause excessive wear to socket contacts or shutters of sockets-outlets		P
12.9.5.2	Adaptors with ISOD shall not cause excessive wear to socket contacts or shutters of sockets-outlets. One type of socket-outlet shall preferably have a shutter-operating ramp of metal.		P
12.9.6.1	1 Nm torque test on the opposite two directions according to figure 33		P
12.11	Retention of pins		P
12.12	Flexibility of pins		P
12.13	Suitable means shall be provided for withdrawing the plug without subjecting the flexible cable to stress.		P
12.16	Insulating sleeves on pins		P
12.17	Abrasion resistance of insulating sleeve		P
12.17.4	Placed in a heating cabinet at not less than 200(0, -8) °C for a period of 120(0, -5) min, after which the specimen is removed and immediately cooled by immersion in water at approximately room temperature. The thickness of the insulation remaining at the point of impression is measured and shall not have been reduced by more than 50 %.	The test carried out at 200 °C for 120 min	P
22.2	75°C ball pressure test to all parts of insulating material including ISOD		P

Attachment No. 4

BS 1363-1:2016+A1:2018			
Clause	Requirement – Test	Result – Remarks	Verdict
23.2	750°C GWT to retain live parts in position including ISOD. 650°C GWT to parts not necessary to retain live parts in position.		P

BS 1363-3:2016+A1:2018			
Clause	Requirement – Test	Result – Remarks	Verdict
12.7	Fixing of cover		N/A
13.10	The total mass of the equipment with all specified connectors shall not exceed 800g. The torque exerted on socket shall not exceed 0.7 Nm	Measured torque: max. 0.029Nm (For models CZH015xxxxyyyBSWH, CZH015xxxxyyyBSWHL); Measured torque: max. 0.030Nm (For models CZH015xxxxyyyBSWP, CZH015xxxxyyyBSWPL); Measured torque: max. 0.039Nm (For models CZH015xxxxyyyBSWHG, CZH015xxxxyyyBSWHLG); Measured torque: max. 0.040Nm (For models CZH015xxxxyyyBSWPG, CZH015xxxxyyyBSWPLG)	P

Page 21 of 51
Report No.: 65.250.18.010.05
Attachment No. 4

Clause 12.2: Dimensions measurement				
Dimensions(mm)	Sample 1	Sample 2	Sample 3	Limit
A	24.60	24.58	24.63	25.37 max
B	31.43	31.40	31.42	34.6 max
C	24.88	24.87	24.88	15 min.
D	10.00	9.98	9.99	9.5 min.
E (L-E)	11.08	11.08	11.09	11.05-11.18
E (N-E)	11.08	11.09	11.09	11.05-11.18
F (L-E)	22.15	22.18	22.15	22.10-22.36
F (N-E)	22.15	22.18	22.15	22.10-22.36
G1	6.24	6.26	6.26	6.22-6.48
G2	6.24	6.26	6.26	6.22-6.48
H	3.96	4.00	3.99	3.90-4.05
I	22.28	22.28	22.30	22.23-23.23
J	1.48	1.50	1.49	1.35-1.85
K(earth)	N/A	N/A	N/A	7.80-8.05
K (ISOD)	7.88	7.90	7.90	7.75-8.05
L (line)	9.33	9.32	9.34	9.5 max
L (neutral)	9.33	9.32	9.34	9.5 max
M (line)	8.47	8.53	8.46	9.2 max
M (neutral)	8.47	8.53	8.46	9.2 max
N (line)	3.91	3.92	3.92	3.90-4.05
N (neutral)	3.91	3.92	3.92	3.90-4.05
O (line)	17.80	17.85	17.80	17.20-18.20
O (neutral)	17.80	17.85	17.80	17.20-18.20
P (line)	1.48	1.50	1.49	1.35-1.85
P (neutral)	1.48	1.50	1.49	1.35-1.85
Q	8.53	8.56	8.55	6.35 min.
R (line)	1.59	1.58	1.60	1.2-2.0
R (neutral)	1.59	1.58	1.60	1.2-2.0
W	R0.22	R0.23	R0.22	R 0.1-1.0
θ 1	61.53°	61.63°	61.65°	58°-62°
θ 2 (line)	68.84°	68.62°	69.45°	60°-80°
θ 2 (neutral)	68.84°	68.62°	69.45°	60°-80°
X1 (for Solid ISOD only)	0.01	0.02	0.02	0.15 max
X2 (for Solid ISOD only)	0.02	0.02	0.01	0.15 max
H1 (for Castellated ISOD only)	N/A	N/A	N/A	≥ 0.6H (use the max. measured value to calculate limit)
K1 (for Castellated ISOD only)	N/A	N/A	N/A	≥ 0.13K (use the max. measured value to calculate limit)
K2 (for Castellated ISOD only)	N/A	N/A	N/A	≥ 0.13K (use the max. measured value to calculate limit)
X3 (for Castellated ISOD only)	N/A	N/A	N/A	0.15 max
X4 (for Castellated ISOD only)	N/A	N/A	N/A	0.15 max
Alternative chamfers on L and N pin				
S (line)	N/A	N/A	N/A	1.35-1.85
S (neutral)	N/A	N/A	N/A	1.35-1.85
θ 3 (line)	N/A	N/A	N/A	58°-62°
θ 3 (neutral)	N/A	N/A	N/A	58°-62°
θ 4 (line)	61.53°	61.63°	61.65°	58°-62°
θ 4 (neutral)	61.53°	61.63°	61.65°	58°-62°
T (line)	1.48	1.50	1.49	1.35-1.85
T(neutral)	1.48	1.50	1.49	1.35-1.85
U (line)	N/A	N/A	N/A	0.2 Max.
U(neutral)	N/A	N/A	N/A	0.2 Max.
V (line)	N/A	N/A	N/A	1.35-1.85

V(neutral)	N/A	N/A	N/A	1.35-1.85
------------	-----	-----	-----	-----------

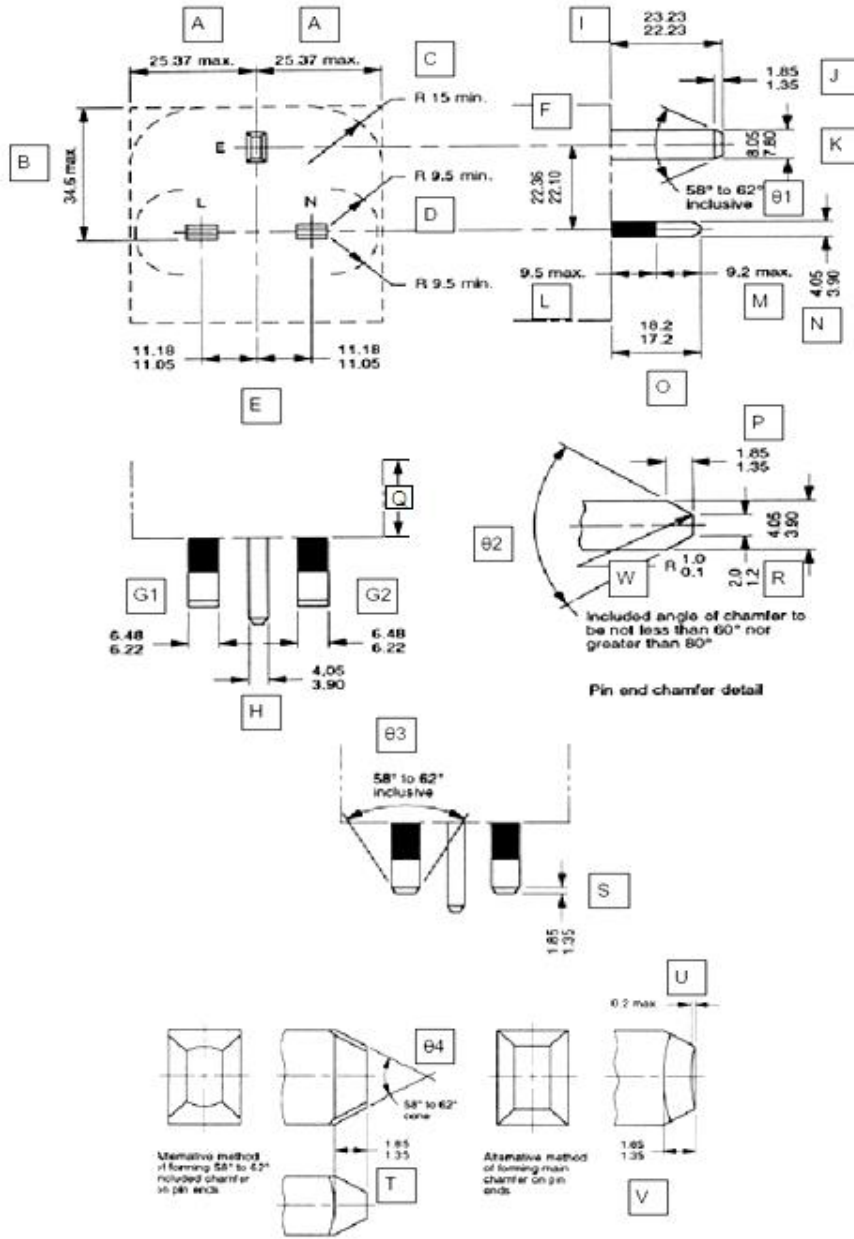

Attachment No. 4

Solid ISOD

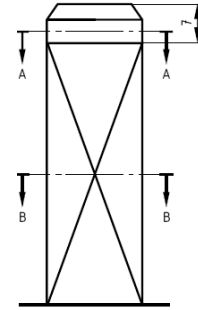
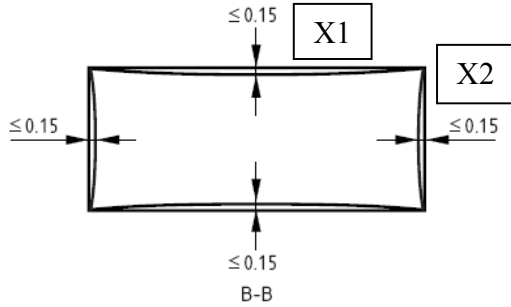

Castellated ISOD

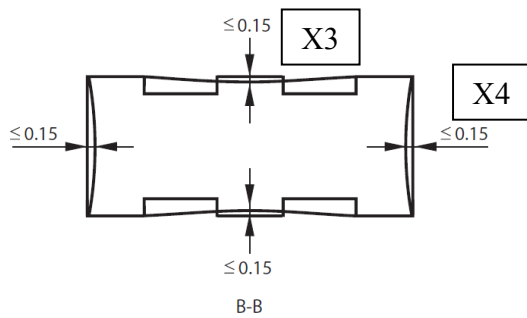
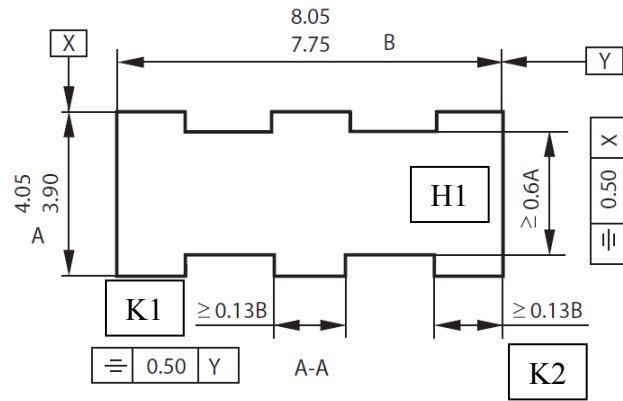
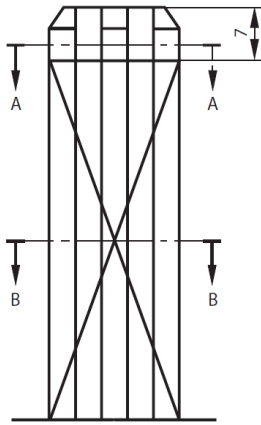

Attachment No. 4

“UK plug portion test” according to BS 1363-1:2016+A1:2018

For models: CZH015xxxxyyBSWM, CZH015xxxxyyBSWF, CZH015xxxxyyBSWML, CZH015xxxxyyBSWFL, CZH015xxxxyyBSWMLG, CZH015xxxxyyBSWFLG, CZH015050yyyBSUM

BS 1363-1:2016+A1:2018			
Clause	Requirement – Test	Result – Remarks	Verdict
12.1	Disposition of pins		P
12.2	Dimensions	(See appended table)	P
12.2.1	Gauging test according to figure 5, the plug portion shall enter the gauge fully with a force less than 10N	Applied force: 8N	P
	In the case of adaptors with ISODs, the test given in 13.8 of BS 1363-2:2016 shall be applied and the maximum withdrawal force from a socket-outlet conforming to BS 1363-2:2016 shall not exceed 36N	Applied force: 10N	P
12.3	Distance of pins from periphery	Measured distance: min. 10.13mm	P
12.7	Plugs shall be so designed and constructed that they cannot readily be deformed to allow access to live parts		P
12.7.1	A force of 30N is applied to the accessible surface, the probe shall not be possible to touch live parts		P
12.9	Construction of pins		P
12.9.1	All exposed surfaces of the adaptor plug pins shall be smooth and free from burrs or sharp edges and other irregularities.		P
12.9.2	Those surfaces of the non-solid plug pins which are visible when the plug is correctly assembled shall be free of apertures.		N/A
12.9.3	All seams and joints of non-solid pins shall be closed over their entire length.		P
12.9.3.1	Conformity shall be checked by inspection and in case of doubt by the following test. Push a steel test probe of 0.2 mm diameter into all seams and joints. Check that the test probe does not enter into any seam or joint to a depth greater than the thickness of the material from which the plug pin is formed.		P
12.9.4.1	For solid pins, applying a force 1100N on the pin according to figure 32.		P

Attachment No. 4

BS 1363-1:2016+A1:2018			
Clause	Requirement – Test	Result – Remarks	Verdict
12.9.4.2	For non-solid pins, conformity shall be checked by the following test. 1) Applying a force 800N on the pin according to Figure 32. 50 times without impact. 2) Separate specimens applying a force 1100N on the pin according to Figure 32.		N/A
12.9.4.3	For ISOD, applying a force 400N on the pin according to figure 32.		P
12.9.5	Plugs with nickel plated brass pins, non-solid pins and/or ISODs shall not cause excessive wear to socket contacts or shutters of socket-outlets in accordance with BS 1363-2:2016. For plugs with nickel plated brass pins and/or non-solid pins conformity shall be checked by 12.9.5.1. For plugs with ISODs conformity shall be checked by 12.9.5.2.		P
12.9.5.1	Adaptors with nickel plated brass pins and/or non-solid pins shall not cause excessive wear to socket contacts or shutters of sockets-outlets		P
12.9.5.2	Adaptors with ISOD shall not cause excessive wear to socket contacts or shutters of sockets-outlets. One type of socket-outlet shall preferably have a shutter-operating ramp of metal.		P
12.9.6.1	1 Nm torque test on the opposite two directions according to figure 33		P
12.11	Retention of pins		P
12.12	Flexibility of pins		P
12.13	Suitable means shall be provided for withdrawing the plug without subjecting the flexible cable to stress.		P
12.16	Insulating sleeves on pins		P
12.17	Abrasion resistance of insulating sleeve		P
12.17.4	Placed in a heating cabinet at not less than 200(0, -8) °C for a period of 120(0, -5) min, after which the specimen is removed and immediately cooled by immersion in water at approximately room temperature. The thickness of the insulation remaining at the point of impression is measured and shall not have been reduced by more than 50 %.	The test carried out at 200 °C for 120 min	P
22.2	75°C ball pressure test to all parts of insulating material including ISOD		P

Attachment No. 4

BS 1363-1:2016+A1:2018			
Clause	Requirement – Test	Result – Remarks	Verdict
23.2	750°C GWT to retain live parts in position including ISOD. 650°C GWT to parts not necessary to retain live parts in position.		P

BS 1363-3:2016+A1:2018			
Clause	Requirement – Test	Result – Remarks	Verdict
12.7	Fixing of cover		N/A
13.10	The total mass of the equipment with all specified connectors shall not exceed 800g. The torque exerted on socket shall not exceed 0.7 Nm	Measured torque: max. 0.034Nm (For models CZH015xxxxyyyBSWM, CZH015xxxxyyyBSWML); Measured torque: max. 0.035Nm (For models CZH015xxxxyyyBSWF, CZH015xxxxyyyBSWFL); Measured torque: max. 0.044Nm (For models CZH015xxxxyyyBSWGM, CZH015xxxxyyyBSWMLG); Measured torque: max. 0.045Nm (For models CZH015xxxxyyyBSWFG, CZH015xxxxyyyBSWFLG); Measured torque: max. 0.022Nm (For models CZH015xxxxyyyBSUM)	P

Page 27 of 51
Report No.: 65.250.18.010.05
Attachment No. 4

Clause 12.2: Dimensions measurement				
Dimensions(mm)	Sample 1	Sample 2	Sample 3	Limit
A	24.54	24.52	24.53	25.37 max
B	33.33	33.30	33.35	34.6 max
C	25.33	25.20	25.25	15 min.
D	10.13	10.14	10.13	9.5 min.
E (L-E)	11.06	11.08	11.07	11.05-11.18
E (N-E)	11.06	11.09	11.07	11.05-11.18
F (L-E)	22.13	22.15	22.15	22.10-22.36
F (N-E)	22.13	22.15	22.15	22.10-22.36
G1	6.24	6.25	6.25	6.22-6.48
G2	6.24	6.24	6.26	6.22-6.48
H	4.04	4.03	4.04	3.90-4.05
I	23.01	22.98	22.96	22.23-23.23
J	1.52	1.50	1.53	1.35-1.85
K(earth)	N/A	N/A	N/A	7.80-8.05
K (ISOD)	8.00	7.98	7.97	7.75-8.05
L (line)	9.33	9.32	9.34	9.5 max
L (neutral)	9.33	9.32	9.34	9.5 max
M (line)	8.37	8.36	8.32	9.2 max
M (neutral)	8.37	8.36	8.32	9.2 max
N (line)	3.93	3.94	3.93	3.90-4.05
N (neutral)	3.93	3.94	3.94	3.90-4.05
O (line)	17.70	17.68	17.66	17.20-18.20
O (neutral)	17.70	17.68	17.66	17.20-18.20
P (line)	1.65	1.66	1.69	1.35-1.85
P (neutral)	1.65	1.66	1.69	1.35-1.85
Q	7.24	7.25	7.27	6.35 min.
R (line)	1.59	1.58	1.60	1.2-2.0
R (neutral)	1.59	1.58	1.60	1.2-2.0
W	R0.28	R0.25	R0.22	R 0.1-1.0
θ 1	61.50°	61.53°	61.60°	58°-62°
θ 2 (line)	68.74°	68.68°	69.65°	60°-80°
θ 2 (neutral)	68.74°	68.68°	69.65°	60°-80°
X1 (for Solid ISOD only)	0.01	0.02	0.02	0.15 max
X2 (for Solid ISOD only)	0.02	0.02	0.01	0.15 max
H1 (for Castellated ISOD only)	N/A	N/A	N/A	≥ 0.6H (use the max. measured value to calculate limit)
K1 (for Castellated ISOD only)	N/A	N/A	N/A	≥ 0.13K (use the max. measured value to calculate limit)
K2 (for Castellated ISOD only)	N/A	N/A	N/A	≥ 0.13K (use the max. measured value to calculate limit)
X3 (for Castellated ISOD only)	N/A	N/A	N/A	0.15 max
X4 (for Castellated ISOD only)	N/A	N/A	N/A	0.15 max
Alternative chamfers on L and N pin				
S (line)	N/A	N/A	N/A	1.35-1.85
S (neutral)	N/A	N/A	N/A	1.35-1.85
θ 3 (line)	N/A	N/A	N/A	58°-62°
θ 3 (neutral)	N/A	N/A	N/A	58°-62°
θ 4 (line)	61.44°	61.38°	61.40°	58°-62°
θ 4 (neutral)	61.43°	61.38°	61.45°	58°-62°
T (line)	1.65	1.66	1.69	1.35-1.85
T(neutral)	1.65	1.66	1.69	1.35-1.85
U (line)	N/A	N/A	N/A	0.2 Max.
U(neutral)	N/A	N/A	N/A	0.2 Max.
V (line)	N/A	N/A	N/A	1.35-1.85

V(neutral)	N/A	N/A	N/A	1.35-1.85
------------	-----	-----	-----	-----------

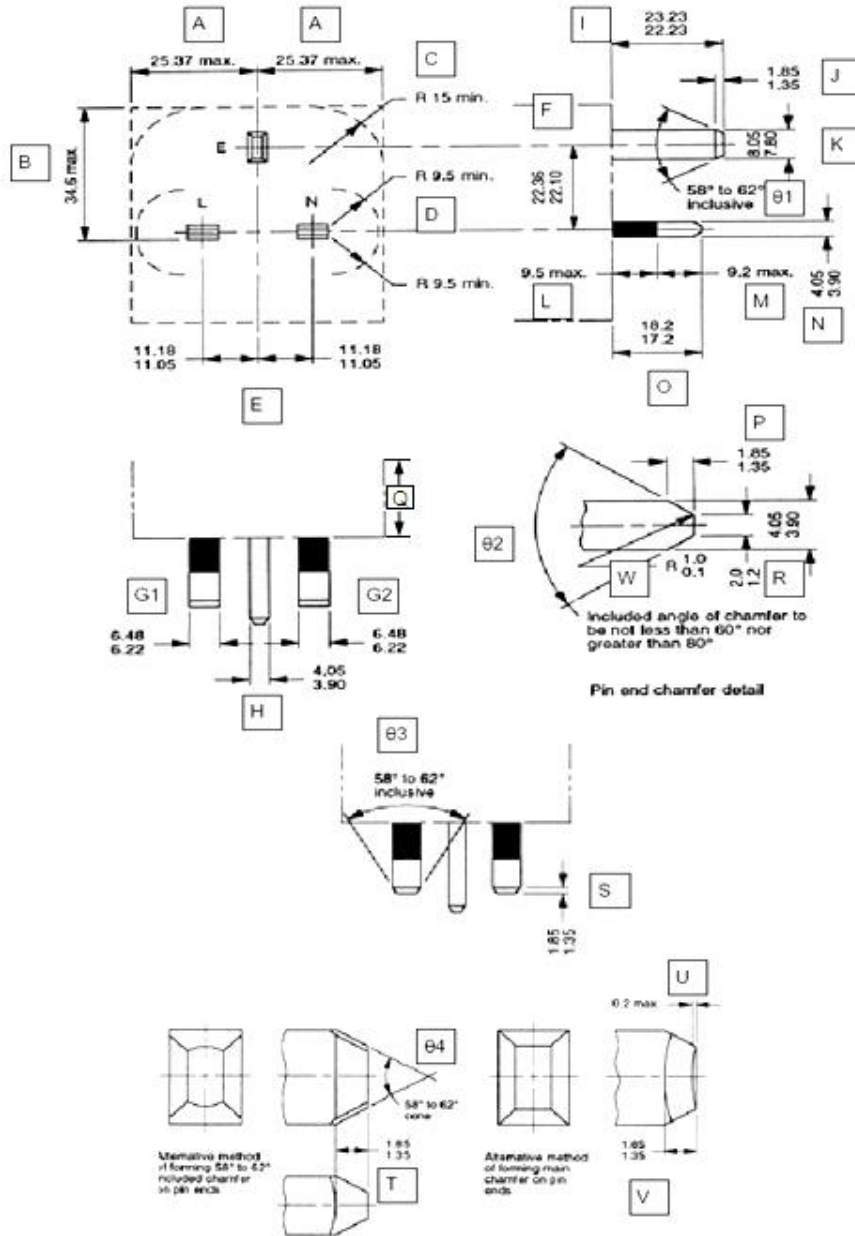

Attachment No. 4

Solid ISOD

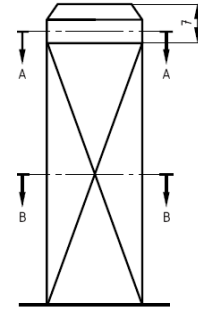
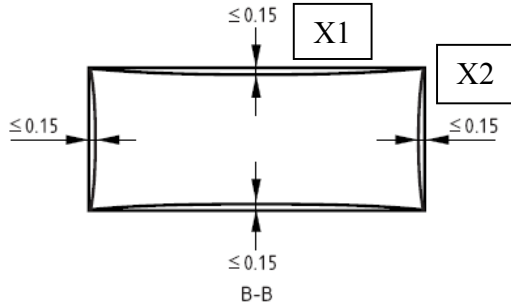

Castellated ISOD

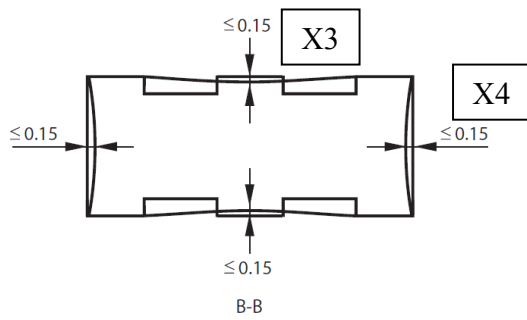
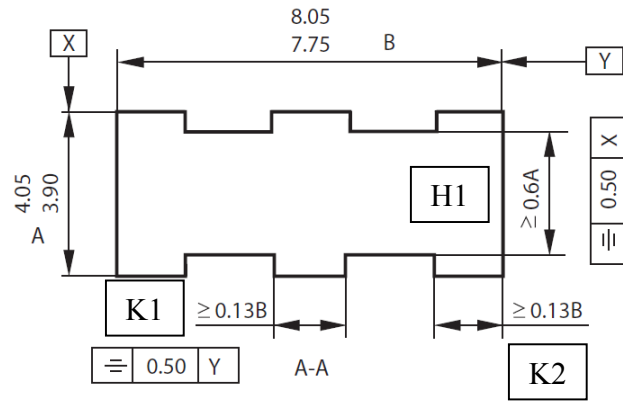
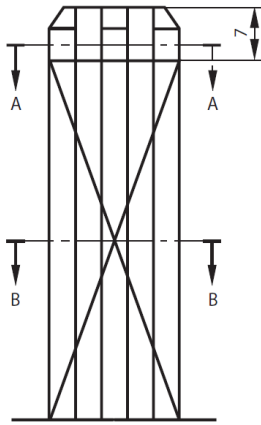

Attachment No. 4

“UK plug portion test” according to BS 1363-1:2016+A1:2018

For models: CZH015xxxxyyTRWM, CZH015xxxxyyTRWF, CZH015xxxxyyTRWML, CZH015xxxxyyTRWFL (with detachable UK plug)

BS 1363-1:2016+A1:2018			
Clause	Requirement – Test	Result – Remarks	Verdict
12.1	Disposition of pins		P
12.2	Dimensions	(See appended table)	P
12.2.1	Gauging test according to figure 5, the plug portion shall enter the gauge fully with a force less than 10N	Applied force: 7N	P
	In the case of adaptors with ISODs, the test given in 13.8 of BS 1363-2:2016 shall be applied and the maximum withdrawal force from a socket-outlet conforming to BS 1363-2:2016 shall not exceed 36N	Applied force: 10N	P
12.3	Distance of pins from periphery	Measured distance: min. 9.82mm	P
12.7	Plugs shall be so designed and constructed that they cannot readily be deformed to allow access to live parts		P
12.7.1	A force of 30N is applied to the accessible surface, the probe shall not be possible to touch live parts		P
12.9	Construction of pins		P
12.9.1	All exposed surfaces of the adaptor plug pins shall be smooth and free from burrs or sharp edges and other irregularities.		P
12.9.2	Those surfaces of the non-solid plug pins which are visible when the plug is correctly assembled shall be free of apertures.		N/A
12.9.3	All seams and joints of non-solid pins shall be closed over their entire length.		P
12.9.3.1	Conformity shall be checked by inspection and in case of doubt by the following test. Push a steel test probe of 0.2 mm diameter into all seams and joints. Check that the test probe does not enter into any seam or joint to a depth greater than the thickness of the material from which the plug pin is formed.		P
12.9.4.1	For solid pins, applying a force 1100N on the pin according to figure 32.		P

Attachment No. 4

BS 1363-1:2016+A1:2018			
Clause	Requirement – Test	Result – Remarks	Verdict
12.9.4.2	For non-solid pins, conformity shall be checked by the following test. 1) Applying a force 800N on the pin according to Figure 32. 50 times without impact. 2) Separate specimens applying a force 1100N on the pin according to Figure 32.		N/A
12.9.4.3	For ISOD, applying a force 400N on the pin according to figure 32.		P
12.9.5	Plugs with nickel plated brass pins, non-solid pins and/or ISODs shall not cause excessive wear to socket contacts or shutters of socket-outlets in accordance with BS 1363-2:2016. For plugs with nickel plated brass pins and/or non-solid pins conformity shall be checked by 12.9.5.1. For plugs with ISODs conformity shall be checked by 12.9.5.2.		P
12.9.5.1	Adaptors with nickel plated brass pins and/or non-solid pins shall not cause excessive wear to socket contacts or shutters of sockets-outlets		P
12.9.5.2	Adaptors with ISOD shall not cause excessive wear to socket contacts or shutters of sockets-outlets. One type of socket-outlet shall preferably have a shutter-operating ramp of metal.		P
12.9.6.1	1 Nm torque test on the opposite two directions according to figure 33		P
12.11	Retention of pins		P
12.12	Flexibility of pins		P
12.13	Suitable means shall be provided for withdrawing the plug without subjecting the flexible cable to stress.		P
12.16	Insulating sleeves on pins		P
12.17	Abrasion resistance of insulating sleeve		P
12.17.4	Placed in a heating cabinet at not less than 200(0, -8) °C for a period of 120(0, -5) min, after which the specimen is removed and immediately cooled by immersion in water at approximately room temperature. The thickness of the insulation remaining at the point of impression is measured and shall not have been reduced by more than 50 %.	The test carried out at 200 °C for 120 min	P
22.2	75°C ball pressure test to all parts of insulating material including ISOD		P

Attachment No. 4

BS 1363-1:2016+A1:2018			
Clause	Requirement – Test	Result – Remarks	Verdict
23.2	750°C GWT to retain live parts in position including ISOD. 650°C GWT to parts not necessary to retain live parts in position.		P

BS 1363-3:2016+A1:2018			
Clause	Requirement – Test	Result – Remarks	Verdict
12.7	Fixing of cover		N/A
13.10	The total mass of the equipment with all specified connectors shall not exceed 800g. The torque exerted on socket shall not exceed 0.7 Nm	Measured torque: max. 0.038Nm (For models CZH015xxxxyyyTRWM, CZH015xxxxyyyTRWML); Measured torque: max. 0.039Nm (For models CZH015xxxxyyyTRWF, CZH015xxxxyyyTRWFL)	P

Attachment No. 4

Clause 12.2: Dimensions measurement				
Dimensions(mm)	Sample 1	Sample 2	Sample 3	Limit
A	24.42	24.40	24.46	25.37 max
B	33.50	33.52	33.52	34.6 max
C	26.88	26.87	26.88	15 min.
D	9.82	9.82	9.83	9.5 min.
E (L-E)	11.16	11.14	11.15	11.05-11.18
E (N-E)	11.16	11.14	11.15	11.05-11.18
F (L-E)	22.23	22.20	22.25	22.10-22.36
F (N-E)	22.23	22.20	22.25	22.10-22.36
G1	6.28	6.27	6.30	6.22-6.48
G2	6.28	6.27	6.30	6.22-6.48
H	4.02	4.04	4.03	3.90-4.05
I	22.58	22.58	22.56	22.23-23.23
J	1.49	1.48	1.49	1.35-1.85
K(earth)	N/A	N/A	N/A	7.80-8.05
K (ISOD)	8.04	8.00	8.02	7.75-8.05
L (line)	9.33	9.34	9.34	9.5 max
L (neutral)	9.33	9.34	9.33	9.5 max
M (line)	8.79	8.76	8.77	9.2 max
M (neutral)	8.79	8.76	8.78	9.2 max
N (line)	3.99	3.98	3.97	3.90-4.05
N (neutral)	3.99	3.98	3.97	3.90-4.05
O (line)	18.12	18.10	18.11	17.20-18.20
O (neutral)	18.12	18.10	18.11	17.20-18.20
P (line)	1.70	1.68	1.69	1.35-1.85
P (neutral)	1.70	1.68	1.69	1.35-1.85
Q	15.07	15.08	15.05	6.35 min.
R (line)	1.52	1.54	1.52	1.2-2.0
R (neutral)	1.52	1.54	1.52	1.2-2.0
W	R0.25	R0.23	R0.25	R 0.1-1.0
θ 1	61.21°	61.32°	61.25°	58°-62°
θ 2 (line)	67.54°	67.62°	67.45°	60°-80°
θ 2 (neutral)	67.54°	67.62°	67.45°	60°-80°
X1 (for Solid ISOD only)	0.01	0.02	0.02	0.15 max
X2 (for Solid ISOD only)	0.02	0.02	0.01	0.15 max
H1 (for Castellated ISOD only)	N/A	N/A	N/A	≥ 0.6H (use the max. measured value to calculate limit)
K1 (for Castellated ISOD only)	N/A	N/A	N/A	≥ 0.13K (use the max. measured value to calculate limit)
K2 (for Castellated ISOD only)	N/A	N/A	N/A	≥ 0.13K (use the max. measured value to calculate limit)
X3 (for Castellated ISOD only)	N/A	N/A	N/A	0.15 max
X4 (for Castellated ISOD only)	N/A	N/A	N/A	0.15 max
Alternative chamfers on L and N pin				
S (line)	N/A	N/A	N/A	1.35-1.85
S (neutral)	N/A	N/A	N/A	1.35-1.85
θ 3 (line)	N/A	N/A	N/A	58°-62°
θ 3 (neutral)	N/A	N/A	N/A	58°-62°
θ 4 (line)	60.89°	60.78°	60.95°	58°-62°
θ 4 (neutral)	60.93°	60.83°	60.95°	58°-62°
T (line)	1.70	1.68	1.69	1.35-1.85
T(neutral)	1.70	1.68	1.69	1.35-1.85
U (line)	N/A	N/A	N/A	0.2 Max.
U(neutral)	N/A	N/A	N/A	0.2 Max.
V (line)	N/A	N/A	N/A	1.35-1.85

V(neutral)	N/A	N/A	N/A	1.35-1.85
------------	-----	-----	-----	-----------

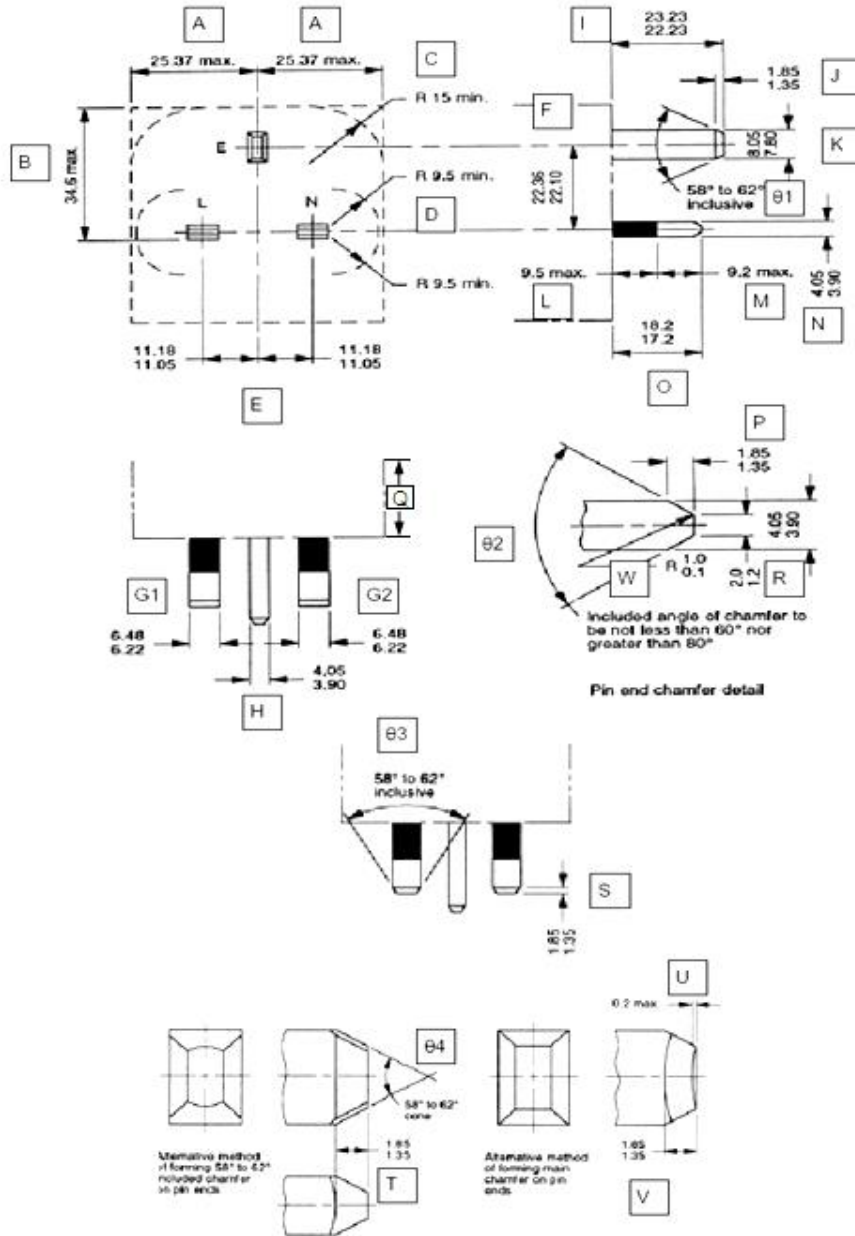

Attachment No. 4

Solid ISOD

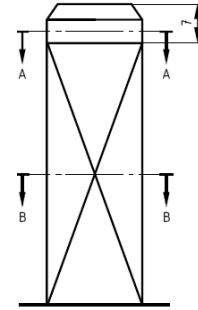
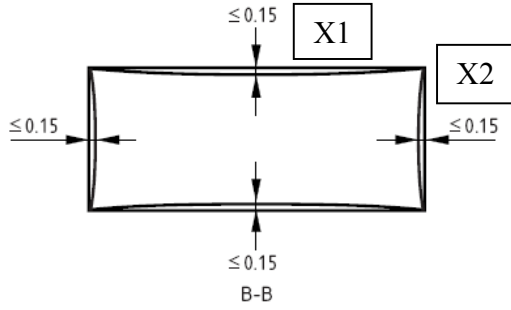

Castellated ISOD

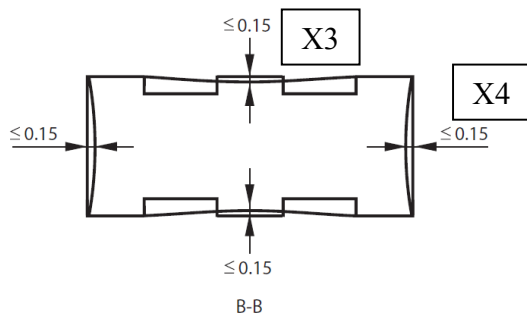
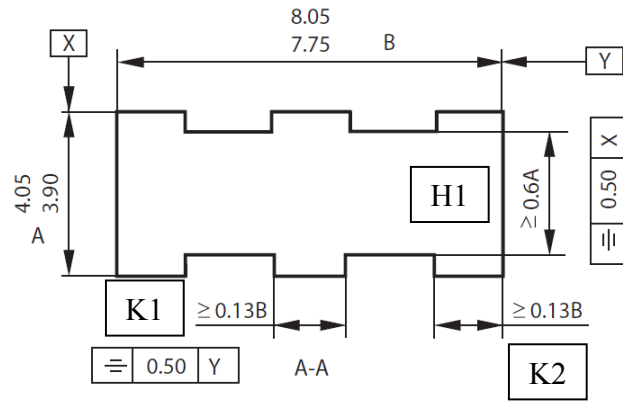
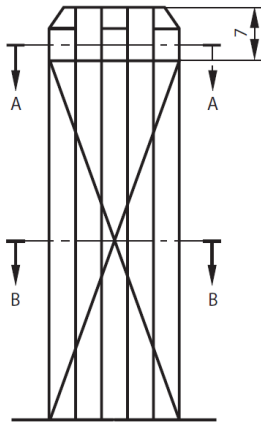

Attachment No. 4

“UK plug portion test” according to BS 1363-1:2016+A1:2018

For models: CZH015xxxxyyyBSWQ, CZH015xxxxyyyBSWQG, CZH015xxxxyyyBSWQL, CZH015xxxxyyyBSWQLG

BS 1363-1:2016+A1:2018			
Clause	Requirement – Test	Result – Remarks	Verdict
12.1	Disposition of pins		P
12.2	Dimensions	(See appended table)	P
12.2.1	Gauging test according to figure 5, the plug portion shall enter the gauge fully with a force less than 10N	Applied force: 7N	P
	In the case of adaptors with ISODs, the test given in 13.8 of BS 1363-2:2016 shall be applied and the maximum withdrawal force from a socket-outlet conforming to BS 1363-2:2016 shall not exceed 36N	Applied force: 12N	P
12.3	Distance of pins from periphery	Measured distance: min. 9.64mm	P
12.7	Plugs shall be so designed and constructed that they cannot readily be deformed to allow access to live parts		P
12.7.1	A force of 30N is applied to the accessible surface, the probe shall not be possible to touch live parts		P
12.9	Construction of pins		P
12.9.1	All exposed surfaces of the adaptor plug pins shall be smooth and free from burrs or sharp edges and other irregularities.		P
12.9.2	Those surfaces of the non-solid plug pins which are visible when the plug is correctly assembled shall be free of apertures.		N/A
12.9.3	All seams and joints of non-solid pins shall be closed over their entire length.		P
12.9.3.1	Conformity shall be checked by inspection and in case of doubt by the following test. Push a steel test probe of 0.2 mm diameter into all seams and joints. Check that the test probe does not enter into any seam or joint to a depth greater than the thickness of the material from which the plug pin is formed.		P
12.9.4.1	For solid pins, applying a force 1100N on the pin according to figure 32.		P
12.9.4.2	For non-solid pins, conformity shall be checked by the following test. 1) Applying a force 800N on the pin according to Figure 32. 50 times without impact. 2) Separate specimens applying a force 1100N on the pin according to Figure 32.		N/A

Attachment No. 4

BS 1363-1:2016+A1:2018			
Clause	Requirement – Test	Result – Remarks	Verdict
12.9.4.3	For ISOD, applying a force 400N on the pin according to figure 32.		P
12.9.5	Plugs with nickel plated brass pins, non-solid pins and/or ISODs shall not cause excessive wear to socket contacts or shutters of socket-outlets in accordance with BS 1363-2:2016. For plugs with nickel plated brass pins and/or non-solid pins conformity shall be checked by 12.9.5.1. For plugs with ISODs conformity shall be checked by 12.9.5.2.		P
12.9.5.1	Adaptors with nickel plated brass pins and/or non-solid pins shall not cause excessive wear to socket contacts or shutters of sockets-outlets		P
12.9.5.2	Adaptors with ISOD shall not cause excessive wear to socket contacts or shutters of sockets-outlets. One type of socket-outlet shall preferably have a shutter-operating ramp of metal.		P
12.9.6.1	1 Nm torque test on the opposite two directions according to figure 33		P
12.11	Retention of pins		P
12.12	Flexibility of pins		P
12.13	Suitable means shall be provided for withdrawing the plug without subjecting the flexible cable to stress.		P
12.16	Insulating sleeves on pins		P
12.17	Abrasion resistance of insulating sleeve		P
12.17.4	Placed in a heating cabinet at not less than 200(0, -8) °C for a period of 120(0, -5) min, after which the specimen is removed and immediately cooled by immersion in water at approximately room temperature. The thickness of the insulation remaining at the point of impression is measured and shall not have been reduced by more than 50 %.	The test carried out at 200 °C for 120 min	P
22.2	75°C ball pressure test to all parts of insulating material including ISOD		P
23.2	750°C GWT to retain live parts in position including ISOD. 650°C GWT to parts not necessary to retain live parts in position.		P

Attachment No. 4

BS 1363-3:2016+A1:2018			
Clause	Requirement – Test	Result – Remarks	Verdict
12.7	Fixing of cover		N/A
13.10	The total mass of the equipment with all specified connectors shall not exceed 800g. The torque exerted on socket shall not exceed 0.7 Nm	Measured torque: max. 0.028Nm (For models CZH015xxxxyyyBSWQ, CZH015xxxxyyyBSWQL); Measured torque: max. 0.038Nm (For models CZH015xxxxyyyBSWQG, CZH015xxxxyyyBSWQLG);	P

Clause 12.2: Dimensions measurement				
Dimensions(mm)	Sample 1	Sample 2	Sample 3	Limit
A	23.67	24.00	23.68	25.37 max
B	32.41	32.42	32.42	34.6 max
C	N/A	N/A	N/A	15 min.
D	9.64	9.66	9.66	9.5 min.
E (L-E)	11.09	11.10	11.09	11.05-11.18
E (N-E)	11.10	11.10	11.11	11.05-11.18
F (L-E)	22.21	22.23	22.23	22.10-22.36
F (N-E)	22.22	22.22	22.20	22.10-22.36
G1	6.30	6.30	6.32	6.22-6.48
G2	6.31	6.30	6.32	6.22-6.48
H	3.94	3.94	3.95	3.90-4.05
I	22.58	22.60	22.58	22.23-23.23
J	1.70	1.68	1.71	1.35-1.85
K(earth)	N/A	N/A	N/A	7.80-8.05
K (ISOD)	7.92	7.92	7.93	7.75-8.05
L (line)	8.66	8.68	8.68	9.5 max
L (neutral)	8.65	8.68	8.67	9.5 max
M (line)	8.56	8.56	8.56	9.2 max
M (neutral)	8.56	8.56	8.55	9.2 max
N (line)	4.00	4.00	4.01	3.90-4.05
N (neutral)	4.00	4.02	4.01	3.90-4.05
O (line)	17.22	17.24	17.24	17.20-18.20
O (neutral)	17.21	17.24	17.22	17.20-18.20
P (line)	1.66	1.65	1.66	1.35-1.85
P (neutral)	1.67	1.65	1.68	1.35-1.85
Q	8.23	8.24	8.24	6.35 min.
R (line)	1.52	1.54	1.54	1.2-2.0
R (neutral)	1.55	1.55	1.53	1.2-2.0
W	0.58	0.64	0.60	R 0.1-1.0
θ 1	61.12°	60.88°	60.90°	58°-62°
θ 2 (line)	72.10°	71.68°	71.96°	60°-80°
θ 2 (neutral)	70.84°	71.64°	71.42°	60°-80°
X1 (for Solid ISOD only)	0.07	0.06	0.08	0.15 max
X2 (for Solid ISOD only)	0.07	0.07	0.09	0.15 max
H1 (for Castellated ISOD only)	N/A	N/A	N/A	≥ 0.6H (use the max. measured value to calculate limit)
K1 (for Castellated ISOD only)	N/A	N/A	N/A	≥ 0.13K (use the max. measured value to calculate limit)
K2 (for Castellated ISOD only)	N/A	N/A	N/A	≥ 0.13K (use the max. measured value to calculate limit)

Attachment No. 4

X3 (for Castellated ISOD only)	N/A	N/A	N/A	0.15 max
X4 (for Castellated ISOD only)	N/A	N/A	N/A	0.15 max
Alternative chamfers on L and N pin				
S (line)	N/A	N/A	N/A	1.35-1.85
S (neutral)	N/A	N/A	N/A	1.35-1.85
θ 3 (line)	N/A	N/A	N/A	58°-62°
θ 3 (neutral)	N/A	N/A	N/A	58°-62°
θ 4 (line)	60.56°	60.88°	61.04°	58°-62°
θ 4 (neutral)	60.20°	61.06°	60.80°	58°-62°
T (line)	1.66	1.65	1.66	1.35-1.85
T (neutral)	1.67	1.65	1.68	1.35-1.85
U (line)	N/A	N/A	N/A	0.2 Max.
U (neutral)	N/A	N/A	N/A	0.2 Max.
V (line)	N/A	N/A	N/A	1.35-1.85
V (neutral)	N/A	N/A	N/A	1.35-1.85

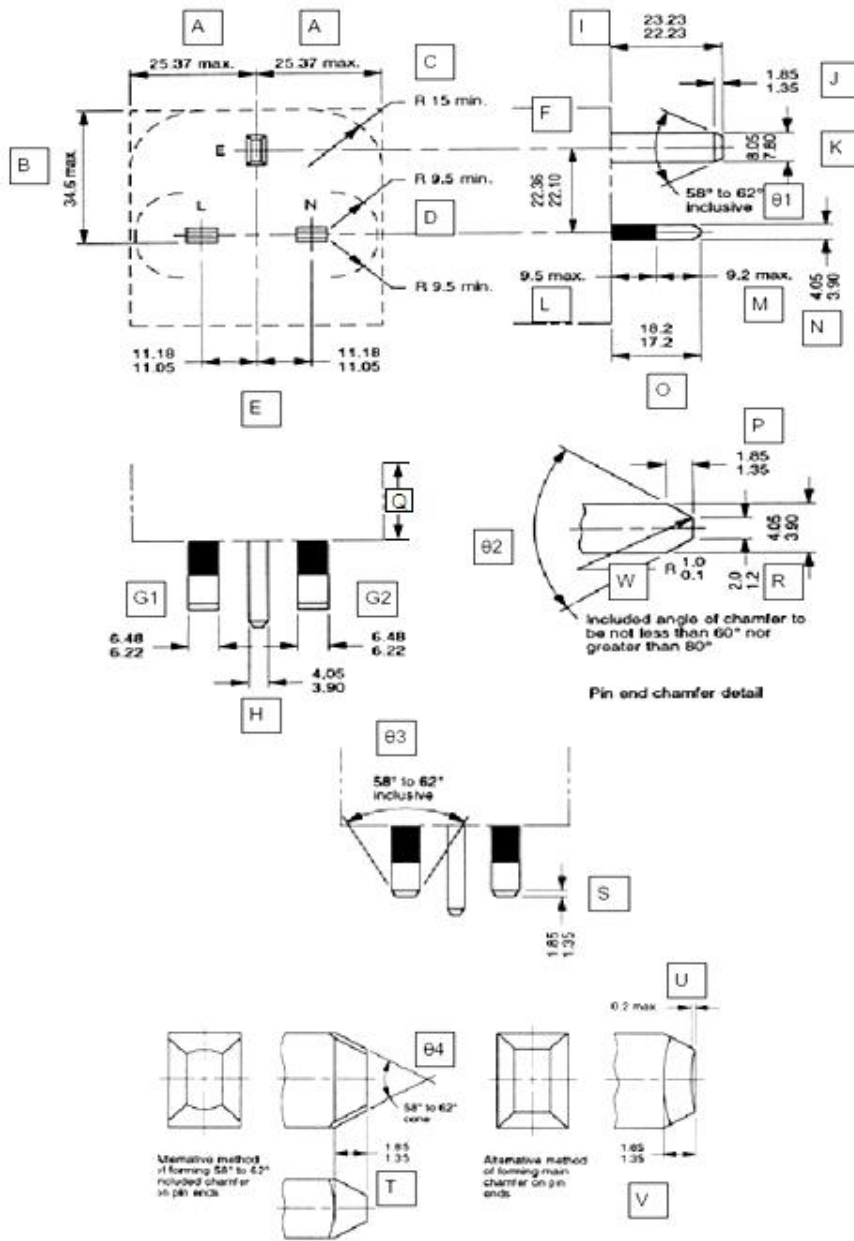

Solid ISOD

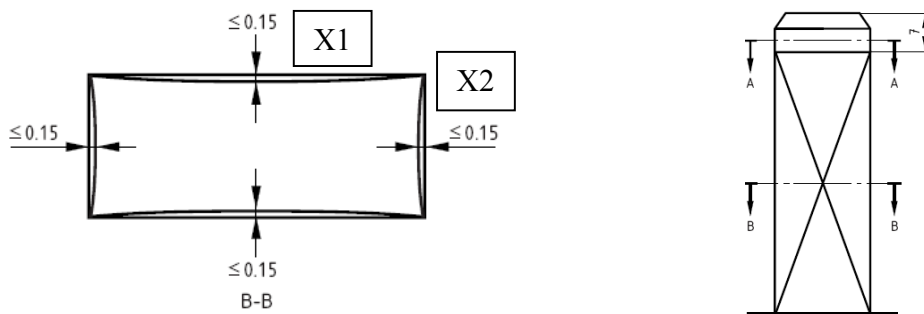

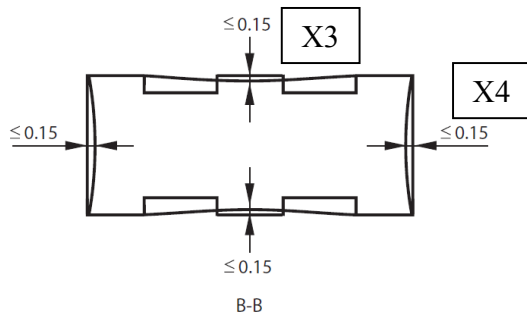
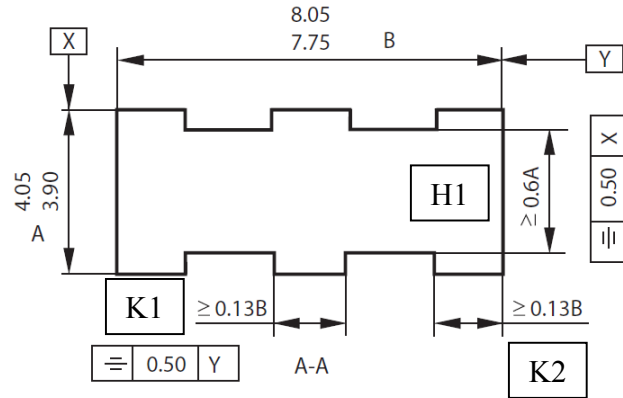
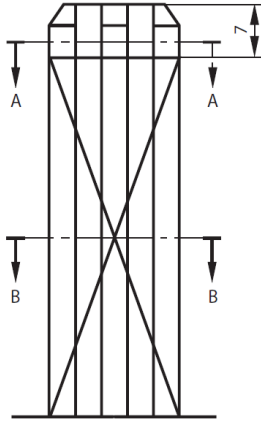

Attachment No. 4

“UK plug portion test” according to BS 1363-1:2016+A1:2018

For models: CZH015xxxxyyTRWQ, CZH015xxxxyyTRWQL with detachable UK plug

BS 1363-1:2016+A1:2018			
Clause	Requirement – Test	Result – Remarks	Verdict
12.1	Disposition of pins		P
12.2	Dimensions	(See appended table)	P
12.2.1	Gauging test according to figure 5, the plug portion shall enter the gauge fully with a force less than 10N	Applied force: 7N	P
	In the case of adaptors with ISODs, the test given in 13.8 of BS 1363-2:2016 shall be applied and the maximum withdrawal force from a socket-outlet conforming to BS 1363-2:2016 shall not exceed 36N	Applied force: 12N	P
12.3	Distance of pins from periphery	Measured distance: min. 9.64mm	P
12.7	Plugs shall be so designed and constructed that they cannot readily be deformed to allow access to live parts		P
12.7.1	A force of 30N is applied to the accessible surface, the probe shall not be possible to touch live parts		P
12.9	Construction of pins		P
12.9.1	All exposed surfaces of the adaptor plug pins shall be smooth and free from burrs or sharp edges and other irregularities.		P
12.9.2	Those surfaces of the non-solid plug pins which are visible when the plug is correctly assembled shall be free of apertures.		N/A
12.9.3	All seams and joints of non-solid pins shall be closed over their entire length.		P
12.9.3.1	Conformity shall be checked by inspection and in case of doubt by the following test. Push a steel test probe of 0.2 mm diameter into all seams and joints. Check that the test probe does not enter into any seam or joint to a depth greater than the thickness of the material from which the plug pin is formed.		P
12.9.4.1	For solid pins, applying a force 1100N on the pin according to figure 32.		P
12.9.4.2	For non-solid pins, conformity shall be checked by the following test. 1) Applying a force 800N on the pin according to Figure 32. 50 times without impact. 2) Separate specimens applying a force 1100N on the pin according to Figure 32.		N/A

Attachment No. 4

BS 1363-1:2016+A1:2018			
Clause	Requirement – Test	Result – Remarks	Verdict
12.9.4.3	For ISOD, applying a force 400N on the pin according to figure 32.		P
12.9.5	Plugs with nickel plated brass pins, non-solid pins and/or ISODs shall not cause excessive wear to socket contacts or shutters of socket-outlets in accordance with BS 1363-2:2016. For plugs with nickel plated brass pins and/or non-solid pins conformity shall be checked by 12.9.5.1. For plugs with ISODs conformity shall be checked by 12.9.5.2.		P
12.9.5.1	Adaptors with nickel plated brass pins and/or non-solid pins shall not cause excessive wear to socket contacts or shutters of sockets-outlets		P
12.9.5.2	Adaptors with ISOD shall not cause excessive wear to socket contacts or shutters of sockets-outlets. One type of socket-outlet shall preferably have a shutter-operating ramp of metal.		P
12.9.6.1	1 Nm torque test on the opposite two directions according to figure 33		P
12.11	Retention of pins		P
12.12	Flexibility of pins		P
12.13	Suitable means shall be provided for withdrawing the plug without subjecting the flexible cable to stress.		P
12.16	Insulating sleeves on pins		P
12.17	Abrasion resistance of insulating sleeve		P
12.17.4	Placed in a heating cabinet at not less than 200(0, -8) °C for a period of 120(0, -5) min, after which the specimen is removed and immediately cooled by immersion in water at approximately room temperature. The thickness of the insulation remaining at the point of impression is measured and shall not have been reduced by more than 50 %.	The test carried out at 200 °C for 120 min	P
22.2	75°C ball pressure test to all parts of insulating material including ISOD		P
23.2	750°C GWT to retain live parts in position including ISOD. 650°C GWT to parts not necessary to retain live parts in position.		P

Attachment No. 4

BS 1363-3:2016+A1:2018			
Clause	Requirement – Test	Result – Remarks	Verdict
12.7	Fixing of cover		N/A
13.10	The total mass of the equipment with all specified connectors shall not exceed 800g. The torque exerted on socket shall not exceed 0.7 Nm	Measured torque: max. 0.028Nm	P

Clause 12.2: Dimensions measurement				
Dimensions(mm)	Sample 1	Sample 2	Sample 3	Limit
A	23.66	23.68	23.66	25.37 max
B	32.42	32.44	32.43	34.6 max
C	N/A	N/A	N/A	15 min.
D	9.66	9.65	9.64	9.5 min.
E (L-E)	11.08	11.09	11.07	11.05-11.18
E (N-E)	11.08	11.10	11.08	11.05-11.18
F (L-E)	22.22	22.22	22.24	22.10-22.36
F (N-E)	22.24	22.24	22.22	22.10-22.36
G1	6.32	6.31	6.33	6.22-6.48
G2	6.34	6.33	6.33	6.22-6.48
H	3.96	3.95	3.95	3.90-4.05
I	22.54	22.56	22.55	22.23-23.23
J	1.72	1.70	1.71	1.35-1.85
K(earth)	N/A	N/A	N/A	7.80-8.05
K (ISOD)	7.91	7.90	7.92	7.75-8.05
L (line)	8.65	8.66	8.64	9.5 max
L (neutral)	8.64	8.64	8.65	9.5 max
M (line)	8.56	8.55	8.54	9.2 max
M (neutral)	8.55	8.54	8.55	9.2 max
N (line)	4.01	4.00	4.01	3.90-4.05
N (neutral)	4.00	4.01	4.00	3.90-4.05
O (line)	17.21	17.21	17.18	17.20-18.20
O (neutral)	17.19	17.18	17.20	17.20-18.20
P (line)	1.67	1.66	1.67	1.35-1.85
P (neutral)	1.66	1.67	1.65	1.35-1.85
Q	14.99	14.98	14.97	6.35 min.
R (line)	1.56	1.55	1.54	1.2-2.0
R (neutral)	1.55	1.54	1.54	1.2-2.0
W	0.54	0.56	0.58	R 0.1-1.0
θ 1	61.36°	60.26°	60.34°	58°-62°
θ 2 (line)	72.44°	71.45°	71.46°	60°-80°
θ 2 (neutral)	70.25°	71.32°	71.40°	60°-80°
X1 (for Solid ISOD only)	0.07	0.06	0.08	0.15 max
X2 (for Solid ISOD only)	0.07	0.07	0.09	0.15 max
H1 (for Castellated ISOD only)	N/A	N/A	N/A	≥ 0.6H (use the max. measured value to calculate limit)
K1 (for Castellated ISOD only)	N/A	N/A	N/A	≥ 0.13K (use the max. measured value to calculate limit)
K2 (for Castellated ISOD only)	N/A	N/A	N/A	≥ 0.13K (use the max. measured value to calculate limit)
X3 (for Castellated ISOD only)	N/A	N/A	N/A	0.15 max

Attachment No. 4

X4 (for Castellated ISOD only)	N/A	N/A	N/A	0.15 max
Alternative chamfers on L and N pin				
S (line)	N/A	N/A	N/A	1.35-1.85
S (neutral)	N/A	N/A	N/A	1.35-1.85
θ 3 (line)	N/A	N/A	N/A	58°-62°
θ 3 (neutral)	N/A	N/A	N/A	58°-62°
θ 4 (line)	60.56°	60.88°	61.04°	58°-62°
θ 4 (neutral)	60.20°	61.06°	60.80°	58°-62°
T (line)	1.66	1.65	1.66	1.35-1.85
T (neutral)	1.67	1.65	1.68	1.35-1.85
U (line)	N/A	N/A	N/A	0.2 Max.
U (neutral)	N/A	N/A	N/A	0.2 Max.
V (line)	N/A	N/A	N/A	1.35-1.85
V (neutral)	N/A	N/A	N/A	1.35-1.85

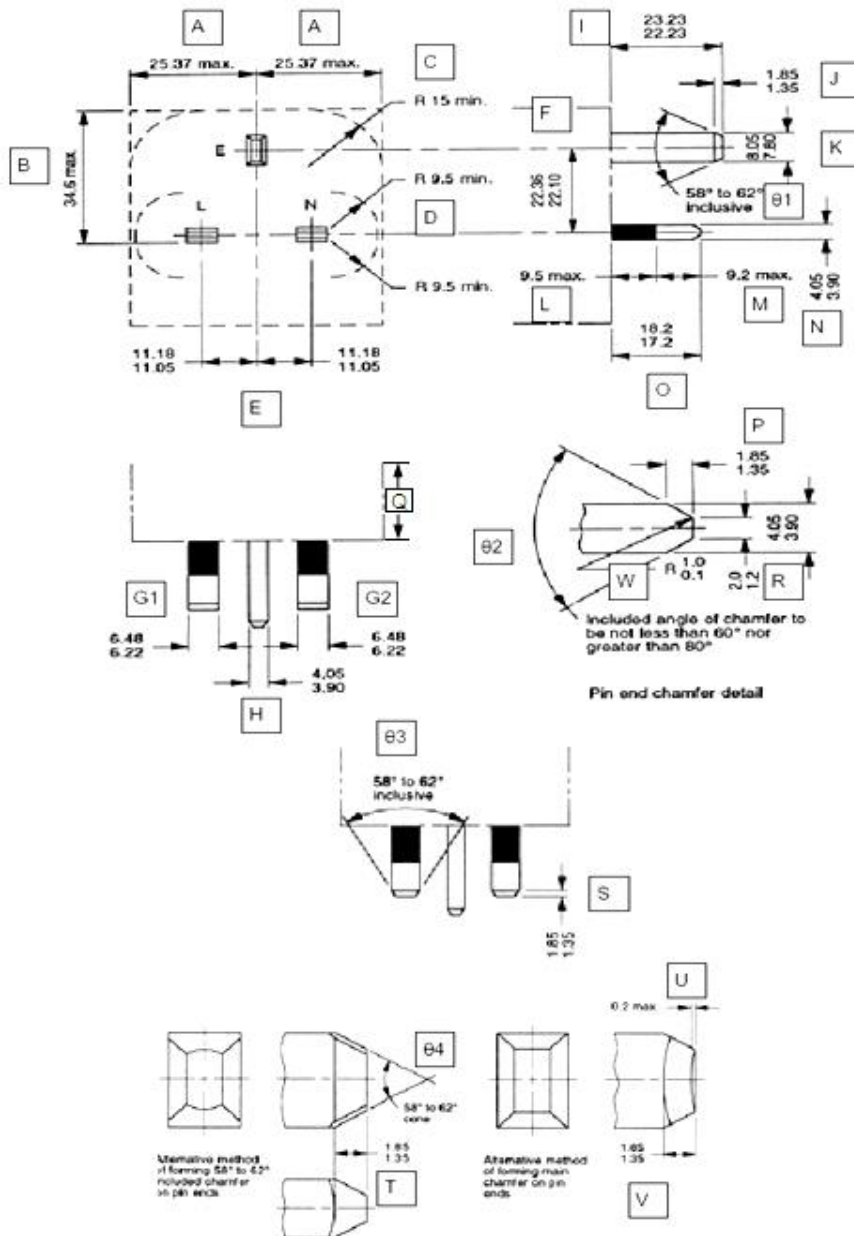

Attachment No. 4

Solid ISOD

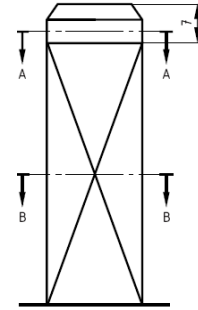
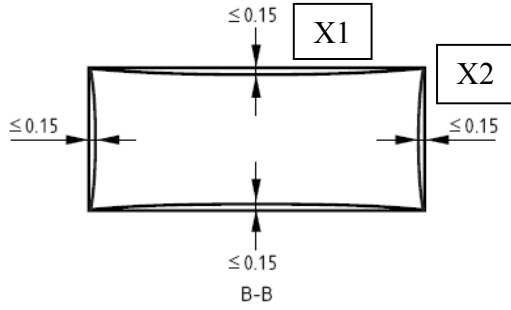

Castellated ISOD

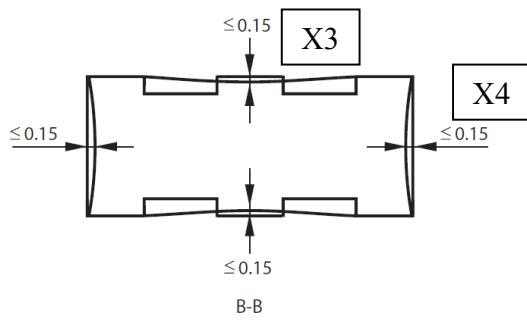
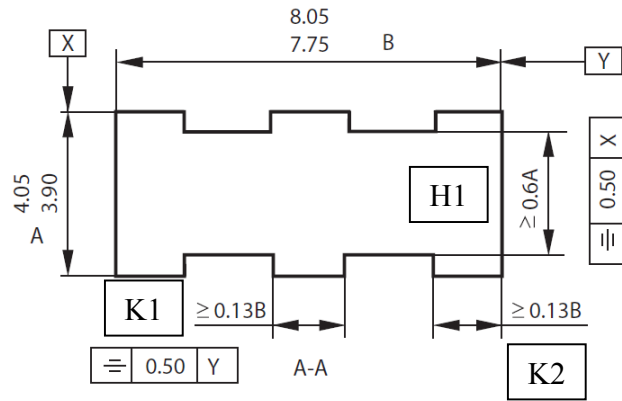
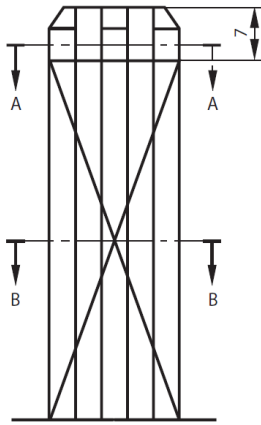

Attachment No. 4

“UK plug portion test” according to BS 1363-1:2016+A1:2018

For models: CZH015050yyyBSUGa

BS 1363-1:2016+A1:2018			
Clause	Requirement – Test	Result – Remarks	Verdict
12.1	Disposition of pins		P
12.2	Dimensions	(See appended table)	P
12.2.1	Gauging test according to figure 5, the plug portion shall enter the gauge fully with a force less than 10N	Applied force: 7N	P
	In the case of adaptors with ISODs, the test given in 13.8 of BS 1363-2:2016 shall be applied and the maximum withdrawal force from a socket-outlet conforming to BS 1363-2:2016 shall not exceed 36N	Applied force: 12N	P
12.3	Distance of pins from periphery	Measured distance: min. 9.62mm	P
12.7	Plugs shall be so designed and constructed that they cannot readily be deformed to allow access to live parts		P
12.7.1	A force of 30N is applied to the accessible surface, the probe shall not be possible to touch live parts		P
12.9	Construction of pins		P
12.9.1	All exposed surfaces of the adaptor plug pins shall be smooth and free from burrs or sharp edges and other irregularities.		P
12.9.2	Those surfaces of the non-solid plug pins which are visible when the plug is correctly assembled shall be free of apertures.		N/A
12.9.3	All seams and joints of non-solid pins shall be closed over their entire length.		P
12.9.3.1	Conformity shall be checked by inspection and in case of doubt by the following test. Push a steel test probe of 0.2 mm diameter into all seams and joints. Check that the test probe does not enter into any seam or joint to a depth greater than the thickness of the material from which the plug pin is formed.		P
12.9.4.1	For solid pins, applying a force 1100N on the pin according to figure 32.		P
12.9.4.2	For non-solid pins, conformity shall be checked by the following test. 1) Applying a force 800N on the pin according to Figure 32. 50 times without impact. 2) Separate specimens applying a force 1100N on the pin according to Figure 32.		N/A

Attachment No. 4

BS 1363-1:2016+A1:2018			
Clause	Requirement – Test	Result – Remarks	Verdict
12.9.4.3	For ISOD, applying a force 400N on the pin according to figure 32.		P
12.9.5	Plugs with nickel plated brass pins, non-solid pins and/or ISODs shall not cause excessive wear to socket contacts or shutters of socket-outlets in accordance with BS 1363-2:2016. For plugs with nickel plated brass pins and/or non-solid pins conformity shall be checked by 12.9.5.1. For plugs with ISODs conformity shall be checked by 12.9.5.2.		P
12.9.5.1	Adaptors with nickel plated brass pins and/or non-solid pins shall not cause excessive wear to socket contacts or shutters of sockets-outlets		P
12.9.5.2	Adaptors with ISOD shall not cause excessive wear to socket contacts or shutters of sockets-outlets. One type of socket-outlet shall preferably have a shutter-operating ramp of metal.		P
12.9.6.1	1 Nm torque test on the opposite two directions according to figure 33		P
12.11	Retention of pins		P
12.12	Flexibility of pins		P
12.13	Suitable means shall be provided for withdrawing the plug without subjecting the flexible cable to stress.		P
12.16	Insulating sleeves on pins		P
12.17	Abrasion resistance of insulating sleeve		P
12.17.4	Placed in a heating cabinet at not less than 200(0, -8) °C for a period of 120(0, -5) min, after which the specimen is removed and immediately cooled by immersion in water at approximately room temperature. The thickness of the insulation remaining at the point of impression is measured and shall not have been reduced by more than 50 %.	The test carried out at 200 °C for 120 min	P
22.2	75°C ball pressure test to all parts of insulating material including ISOD		P
23.2	750°C GWT to retain live parts in position including ISOD. 650°C GWT to parts not necessary to retain live parts in position.		P

Attachment No. 4

BS 1363-3:2016+A1:2018			
Clause	Requirement – Test	Result – Remarks	Verdict
12.7	Fixing of cover		N/A
13.10	The total mass of the equipment with all specified connectors shall not exceed 800g. The torque exerted on socket shall not exceed 0.7 Nm	Measured torque: max. 0.018Nm	P

Clause 12.2: Dimensions measurement				
Dimensions(mm)	Sample 1	Sample 2	Sample 3	Limit
A	23.62	23.68	23.70	25.37 max
B	32.44	32.46	32.45	34.6 max
C	N/A	N/A	N/A	15 min.
D	9.62	9.65	9.64	9.5 min.
E (L-E)	11.08	11.10	11.09	11.05-11.18
E (N-E)	11.10	11.12	11.10	11.05-11.18
F (L-E)	22.26	22.24	22.22	22.10-22.36
F (N-E)	22.25	22.23	22.21	22.10-22.36
G1	6.32	6.32	6.34	6.22-6.48
G2	6.33	6.31	6.30	6.22-6.48
H	3.96	3.94	3.93	3.90-4.05
I	22.59	22.60	22.58	22.23-23.23
J	1.72	1.70	1.71	1.35-1.85
K(earth)	N/A	N/A	N/A	7.80-8.05
K (ISOD)	7.94	7.93	7.95	7.75-8.05
L (line)	8.69	8.70	8.68	9.5 max
L (neutral)	8.66	8.71	8.69	9.5 max
M (line)	8.56	8.57	8.59	9.2 max
M (neutral)	8.57	8.55	8.56	9.2 max
N (line)	4.01	4.00	4.01	3.90-4.05
N (neutral)	4.00	4.01	4.00	3.90-4.05
O (line)	17.25	17.27	17.27	17.20-18.20
O (neutral)	17.23	17.26	17.25	17.20-18.20
P (line)	1.64	1.65	1.65	1.35-1.85
P (neutral)	1.65	1.64	1.66	1.35-1.85
Q	8.26	8.25	8.24	6.35 min.
R (line)	1.54	1.54	1.53	1.2-2.0
R (neutral)	1.52	1.55	1.53	1.2-2.0
W	0.54	0.64	0.62	R 0.1-1.0
θ 1	61.26°	60.46°	60.46°	58°-62°
θ 2 (line)	72.45°	71.65°	71.56°	60°-80°
θ 2 (neutral)	70.85°	71.64°	71.36°	60°-80°
X1 (for Solid ISOD only)	0.06	0.07	0.08	0.15 max
X2 (for Solid ISOD only)	0.06	0.06	0.09	0.15 max
H1 (for Castellated ISOD only)	N/A	N/A	N/A	≥ 0.6H (use the max. measured value to calculate limit)
K1 (for Castellated ISOD only)	N/A	N/A	N/A	≥ 0.13K (use the max. measured value to calculate limit)
K2 (for Castellated ISOD only)	N/A	N/A	N/A	≥ 0.13K (use the max. measured value to calculate limit)
X3 (for Castellated ISOD only)	N/A	N/A	N/A	0.15 max

Attachment No. 4

X4 (for Castellated ISOD only)	N/A	N/A	N/A	0.15 max
Alternative chamfers on L and N pin				
S (line)	N/A	N/A	N/A	1.35-1.85
S (neutral)	N/A	N/A	N/A	1.35-1.85
θ 3 (line)	N/A	N/A	N/A	58°-62°
θ 3 (neutral)	N/A	N/A	N/A	58°-62°
θ 4 (line)	60.46°	60.88°	61.04°	58°-62°
θ 4 (neutral)	60.22°	61.06°	60.80°	58°-62°
T (line)	1.64	1.65	1.65	1.35-1.85
T (neutral)	1.65	1.64	1.66	1.35-1.85
U (line)	N/A	N/A	N/A <td 0.2 Max.	
U (neutral)	N/A	N/A	N/A	0.2 Max.
V (line)	N/A	N/A	N/A	1.35-1.85
V (neutral)	N/A	N/A	N/A	1.35-1.85

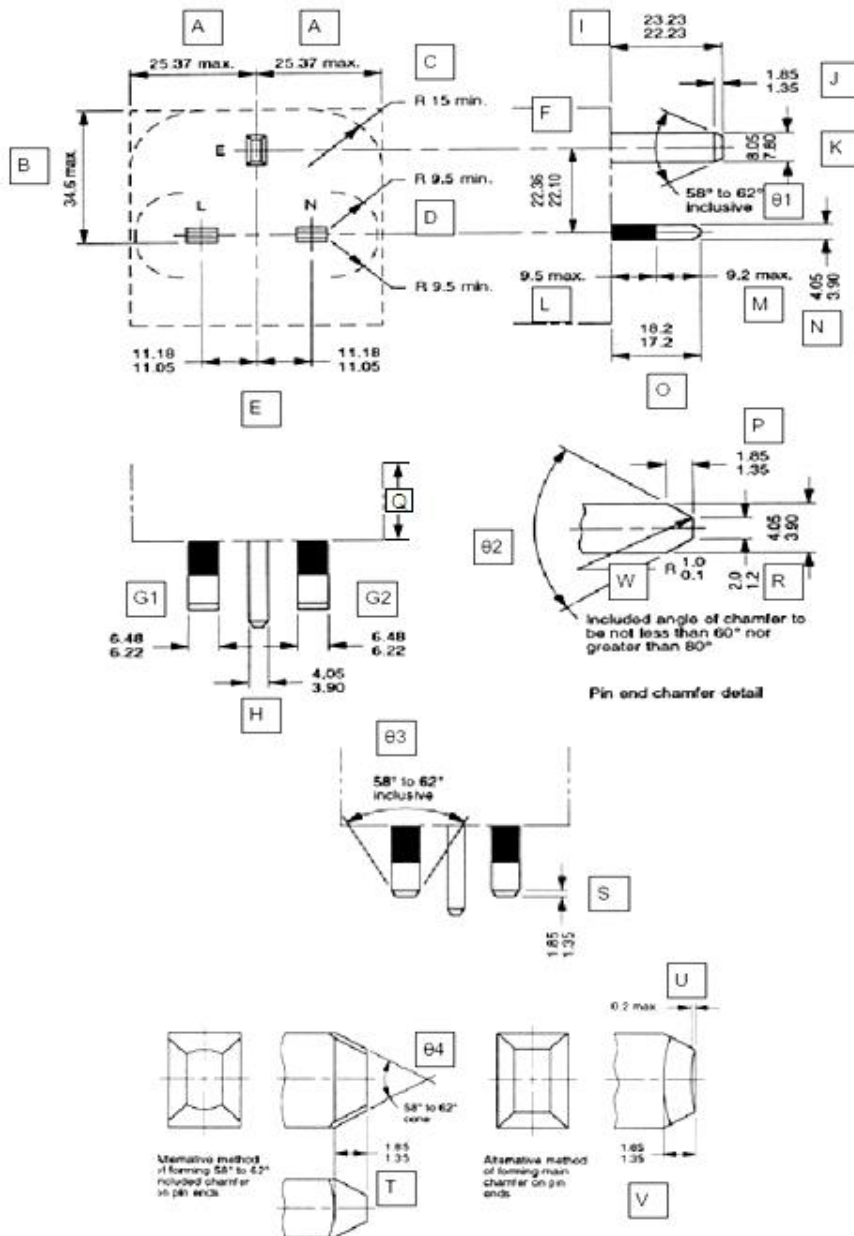

Attachment No. 4

Solid ISOD

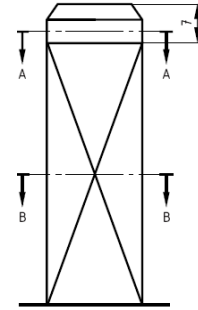
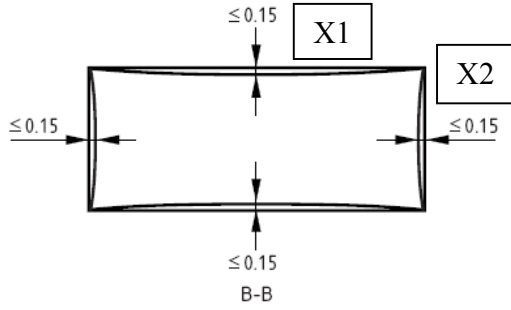

Castellated ISOD

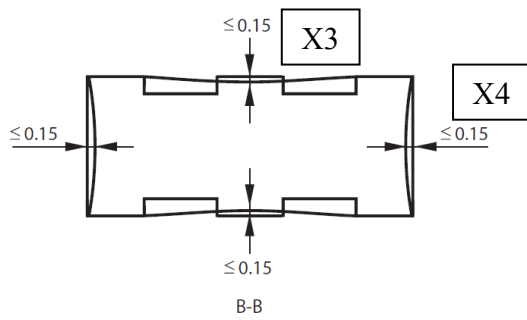
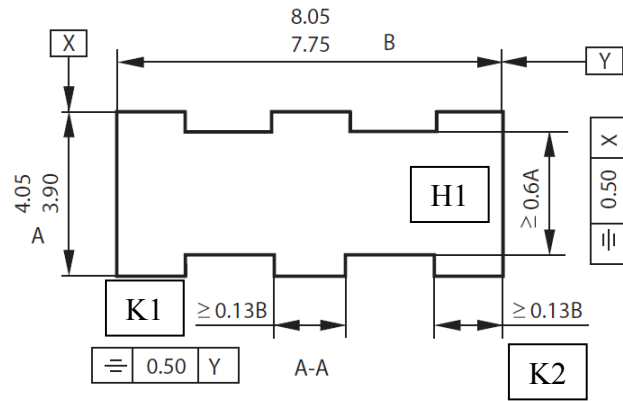
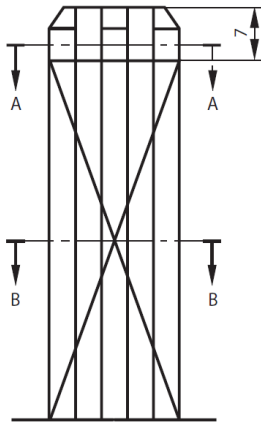

Details of: Overall view-1 (models: CZH015xxxxyyEUWH, CZH015xxxxyyEUWHL, CZH015xxxxyyEUWHG, CZH015xxxxyyEUWHLG)



Details of: Overall view-2 (models: CZH015xxxxyyEUWH, CZH015xxxxyyEUWHG)



Details of: Overall view-3 (models: CZH015xxxxyyEUWHL, CZH015xxxxyyEUWHLG)



Details of: Overall view-4 (models: CZH015xxxxyyEUWP, CZH015xxxxyyEUWPL, CZH015xxxxyyEUWPG, CZH015xxxxyyEUWPLG)



Attachment No. 5

Details of: Overall view-5 (models: CZH015xxxxyyEUWP, CZH015xxxxyyEUWPG)

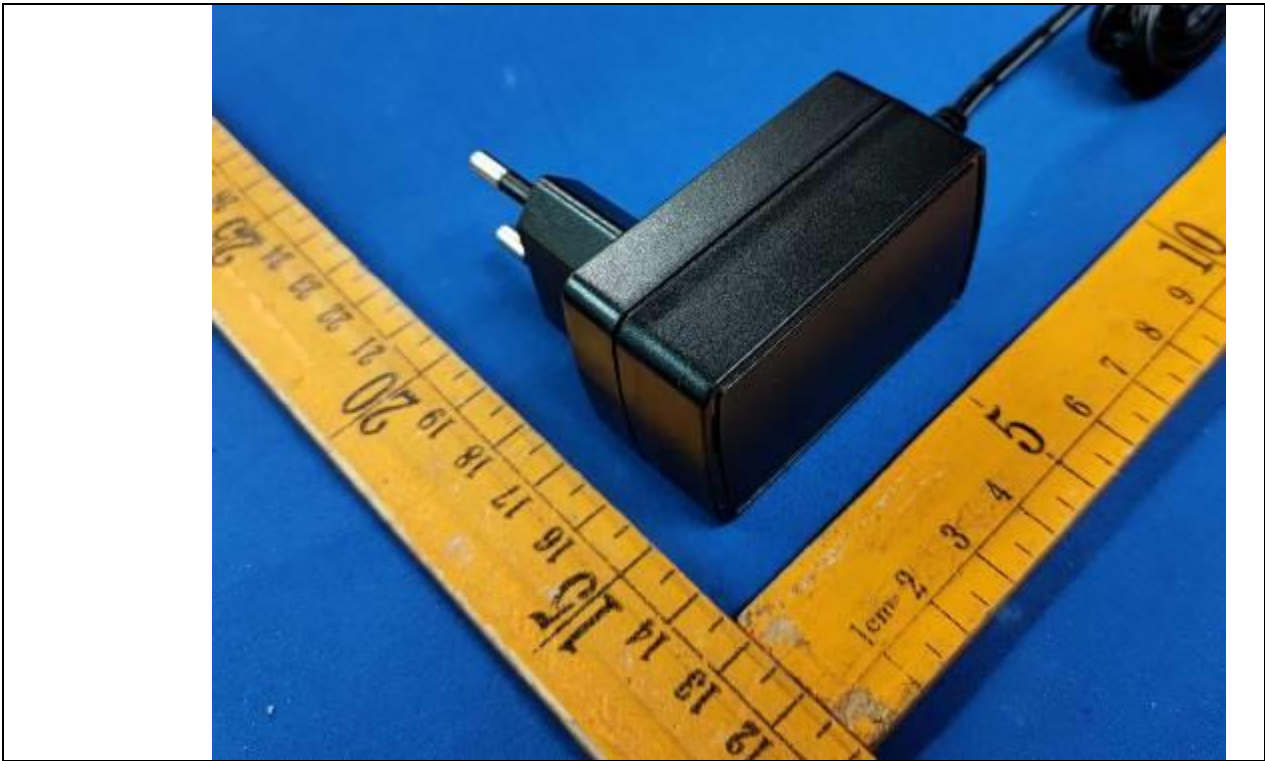

Details of: Overall view-6 (models: CZH015xxxxyyEUWPL, CZH015xxxxyyEUWPLG)



Attachment No. 5

Details of: Overall view-7 (models: CZH015xxxxyyEUWM, CZH015xxxxyyEUWML, CZH015xxxxyyEUWMLG, CZH015xxxxyyEUWMLG)



Details of: Overall view-8 (models: CZH015xxxxyyEUWM, CZH015xxxxyyEUWMLG)



Details of: Overall view-9 (models: CZH015xxxxyyEUWML, CZH015xxxxyyEUWMLG)



Details of: Overall view-10 (models: CZH015xxxxyyEUWF, CZH015xxxxyyEUWFL, CZH015xxxxyyEUWFG, CZH015xxxxyyEUWFLG)



Details of: Overall view-11 (models: CZH015xxxxyyEUWF, CZH015xxxxyyEUWFG)



Details of: Overall view-12 (models: CZH015xxxxyyEUWFL, CZH015xxxxyyEUWFLG)



Details of: Overall view-13 (models: CZH015050yyyEUUM)



Details of: Overall view-14 (models: CZH015050yyyEUUM)



Details of: Overall view-15 (models: CZH015xxxxyyTRWM, CZH015xxxxyyTRWML)



Details of: Overall view-16 (models: CZH015xxxxyyTRWM)



Details of: Overall view-17 (models: CZH015xxxxyyTRWML)



Details of: Overall view-18 (models: CZH015xxxxyyTRWF, CZH015xxxxyyTRWFL)



Details of: Overall view-19 (models: CZH015xxxxyyTRWF)



Details of: Overall view-20 (models: CZH015xxxxyyTRWFL)



Attachment No. 5

Details of: Internal view-21 (models: CZH015xxxxyyTRWM, CZH015xxxxyyTRWF, CZH015xxxxyyTRWML, CZH015xxxxyyTRWFL)



Details of: Internal view-22 (models: CZH015xxxxyyTRWM, CZH015xxxxyyTRWF, CZH015xxxxyyTRWML, CZH015xxxxyyTRWFL)

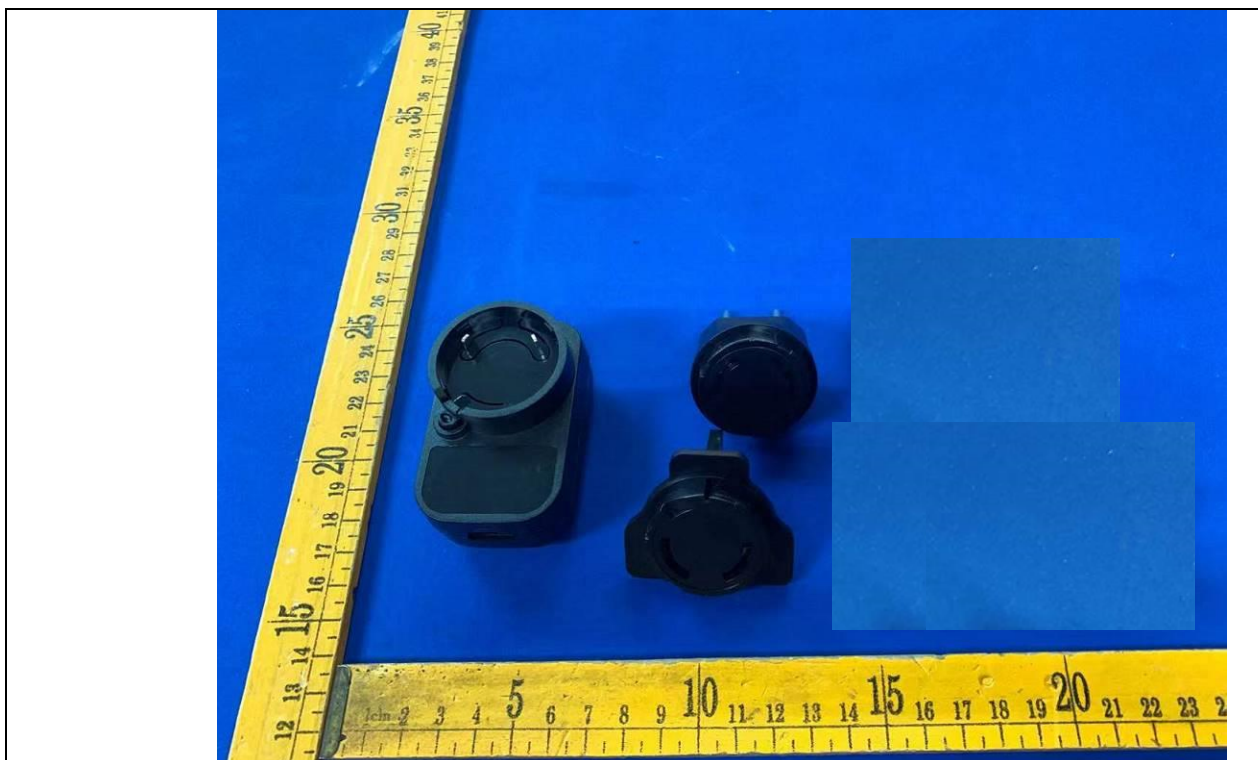

Attachment No. 5

Details of: Overall view-23 (models: CZH015xxxxyyBSWH, CZH015xxxxyyBSWHL,
CZH015xxxxyyBSWHG, CZH015xxxxyyBSWHLG)



Details of: Overall view-24 (models: CZH015xxxxyyBSWH, CZH015xxxxyyBSWHG)



Details of: Overall view-25 (models: CZH015xxxxyyBSWHL, CZH015xxxxyyBSWHLG)



Details of: Overall view-26 (models: CZH015xxxxyyBSWP, CZH015xxxxyyBSWPL, CZH015xxxxyyBSWPG, CZH015xxxxyyBSWPLG)



Attachment No. 5

Details of: Overall view-27 (models: CZH015xxxxyyBSWP, CZH015xxxxyyBSWPG)



Details of: Overall view-28 (models: CZH015xxxxyyBSWPL, CZH015xxxxyyBSWPLG)



Details of: Overall view-29 (models: CZH015xxxxyyBSWM, CZH015xxxxyyBSWML,
CZH015xxxxyyBSWVG, CZH015xxxxyyBSWMLG)



Details of: Overall view-30 (models: CZH015xxxxyyBSWM, CZH015xxxxyyBSWVG)



Details of: Overall view-31 (models: CZH015xxxxyyBSWML, CZH015xxxxyyBSWMLG)



Details of: Overall view-32 (models: CZH015xxxxyyBSWF, CZH015xxxxyyBSWFL, CZH015xxxxyyBSWFG, CZH015xxxxyyBSWFLG)



Details of: Overall view-33 (models: CZH015xxxxyyBSWF, CZH015xxxxyyBSWFG)



Details of: Overall view-34 (models: CZH015xxxxyyBSWFL, CZH015xxxxyyBSWFLG)



Details of: Overall view-35 (models: CZH015050yyyBSUM)



Details of: Overall view-36 (models: CZH015050yyyBSUM)



Details of: Overall view-37 (models: CZH015xxxxyyTRWM, CZH015xxxxyyTRWML)



Details of: Overall view-38 (models: CZH015xxxxyyTRWM)



Details of: Overall view-39 (models: CZH015xxxxyyTRWML)



Details of: Overall view-40 (models: CZH015xxxxyyTRWF, CZH015xxxxyyTRWFL)



Details of: Overall view-41 (models: CZH015xxxxyyTRWF)



Details of: Overall view-42 (models: CZH015xxxxyyTRWFL)



Details of: Overall view-43 (models: CZH015xxxxyyTRWM, CZH015xxxxyyTRWML)



Details of: Overall view-44 (models: CZH015xxxxyyTRWM)



Details of: Overall view-45 (models: CZH015xxxxyyTRWML)



Details of: Overall view-46 (models: CZH015xxxxyyTRWF, CZH015xxxxyyTRWFL)



Details of: Overall view-47 (models: CZH015xxxxyyTRWF)



Details of: Overall view-48 (models: CZH015xxxxyyTRWFL)



Details of: Overall view-49 (models: CZH015xxxxyyyEUWQ, CZH015xxxxyyyBSWQ,
CZH015xxxxyyyEUWQG, CZH015xxxxyyyBSWQG)

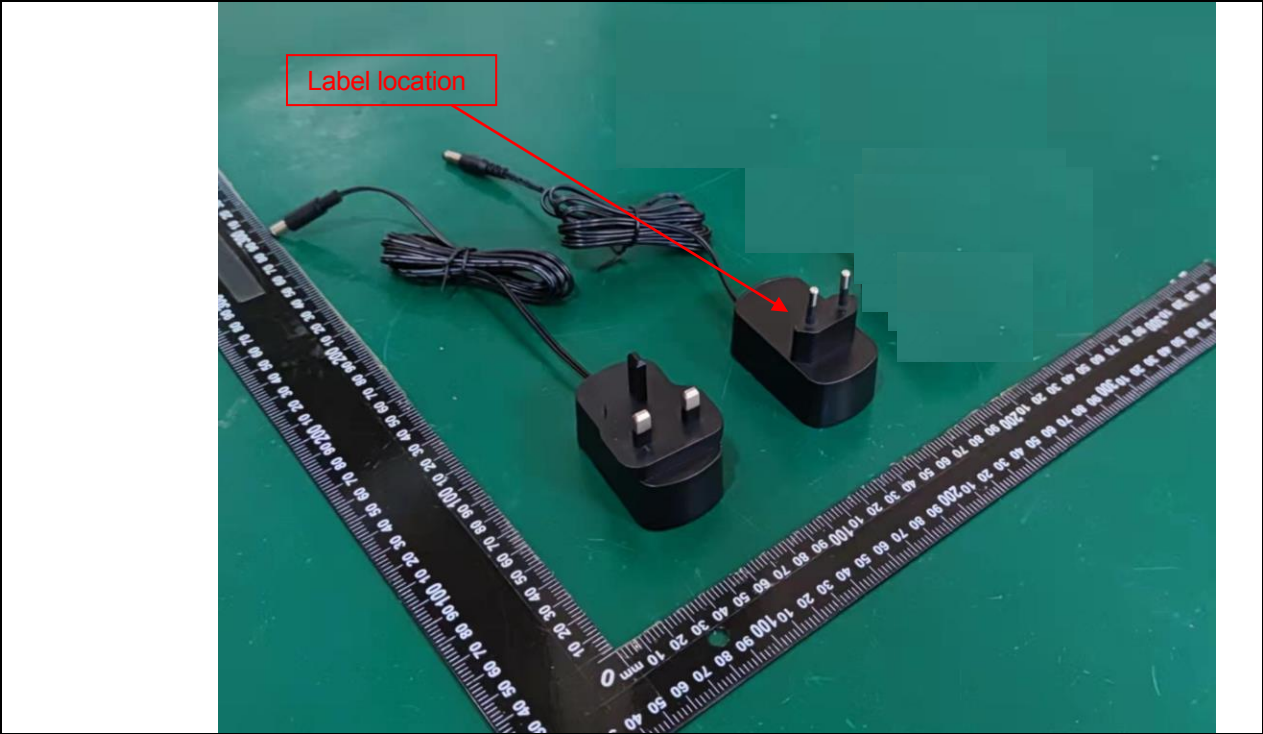

Details of: Overall view-50 (models: CZH015xxxxyyyEUWQ, CZH015xxxxyyyBSWQ,
CZH015xxxxyyyEUWQG, CZH015xxxxyyyBSWQG)

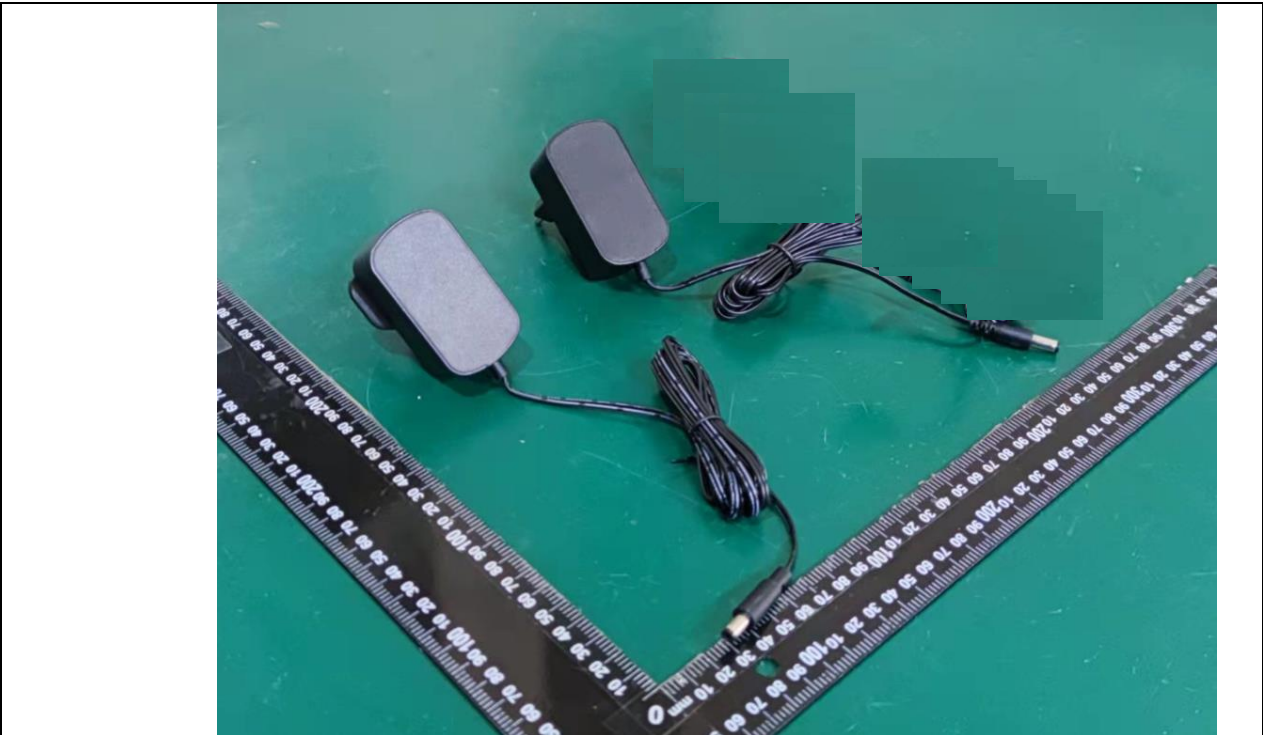

Details of: Overall view-51 (models: CZH015xxxxyyE UWQ, CZH015xxxxyyBSWQ, CZH015xxxxyyE UWQG, CZH015xxxxyyBSWQG)

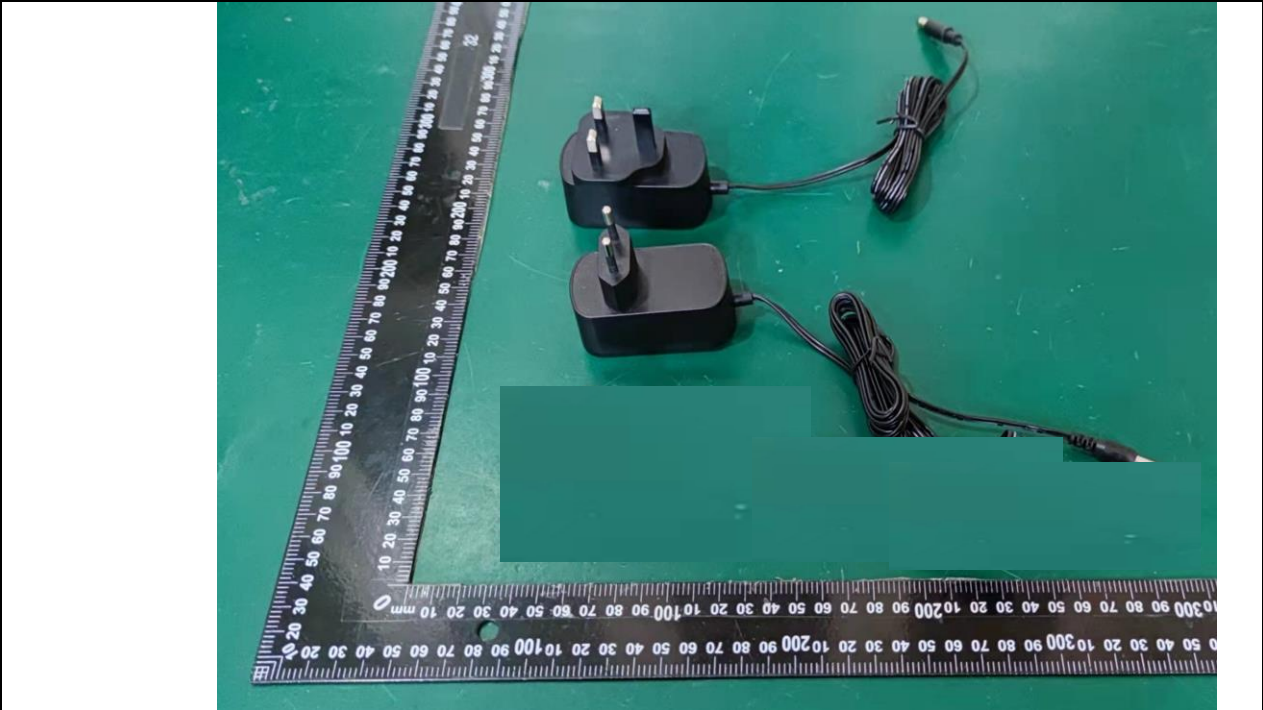

Details of: Overall view-52 (models: CZH015xxxxyyE UWQ, CZH015xxxxyyE UWQG)

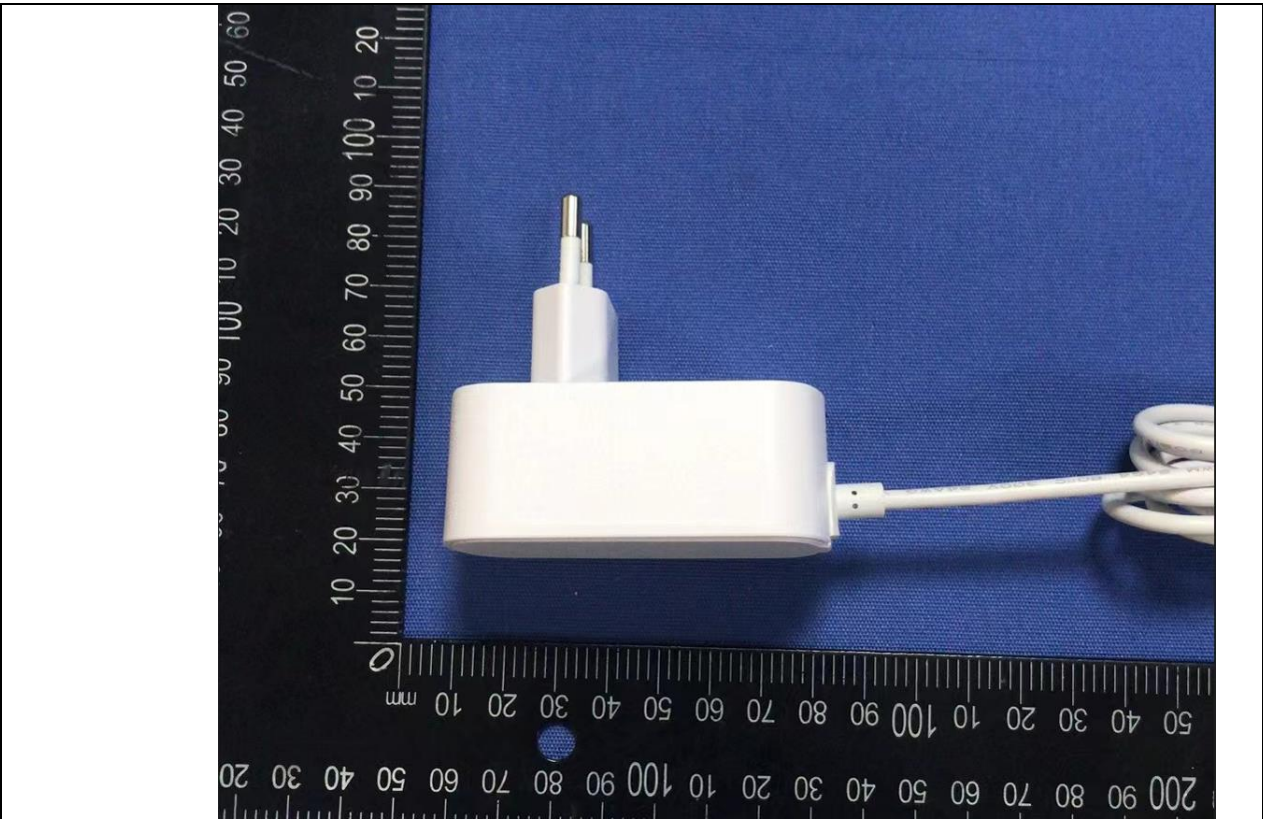

Details of: Overall view-53 (models: CZH015xxxxyyTRWQ)



Details of: Overall view-54 (models: CZH015xxxxyyTRWQ)



Details of: Overall view-55 (models: CZH015xxxxyyTRWQ)



Details of: Overall view-56 (models: CZH015xxxxyyTRWQ)



Details of: Overall view-57 (models: CZH015xxxxyyTRWQL)



Details of: Overall view-58 (models: CZH015xxxxyyEUWAa)

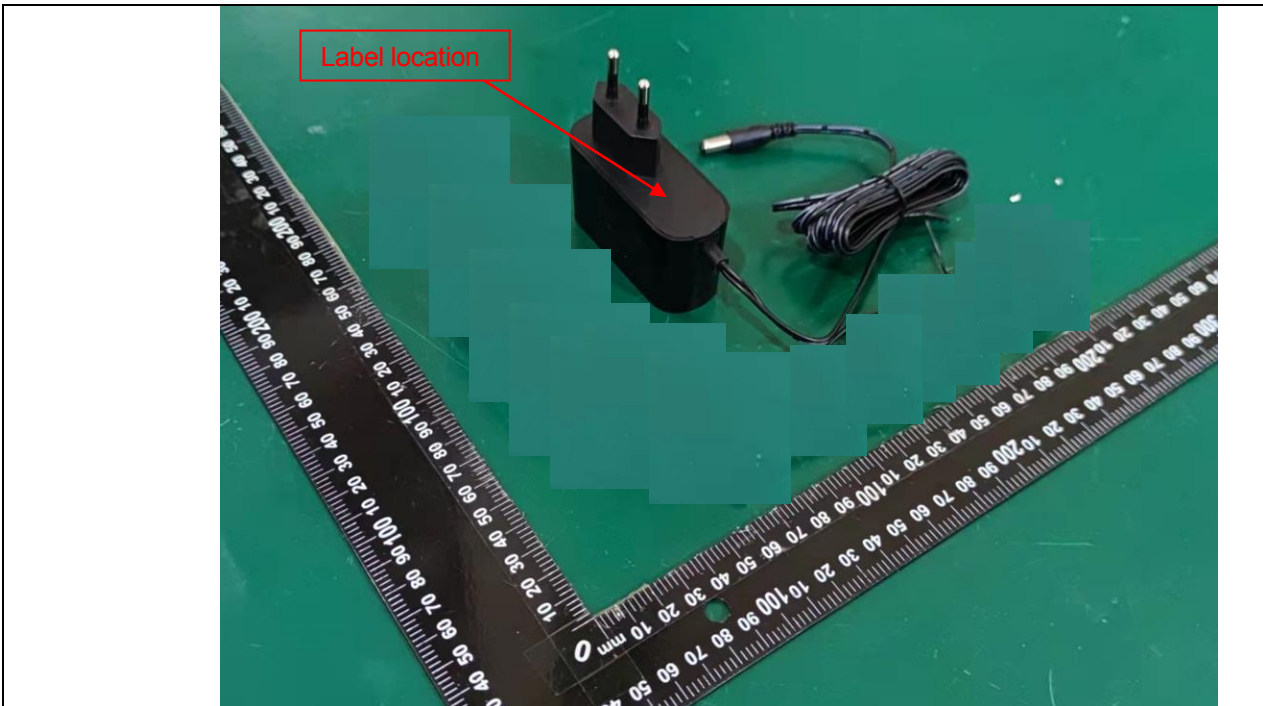

Details of: Overall view-59 (models: CZH015xxxxyyEUWAa)

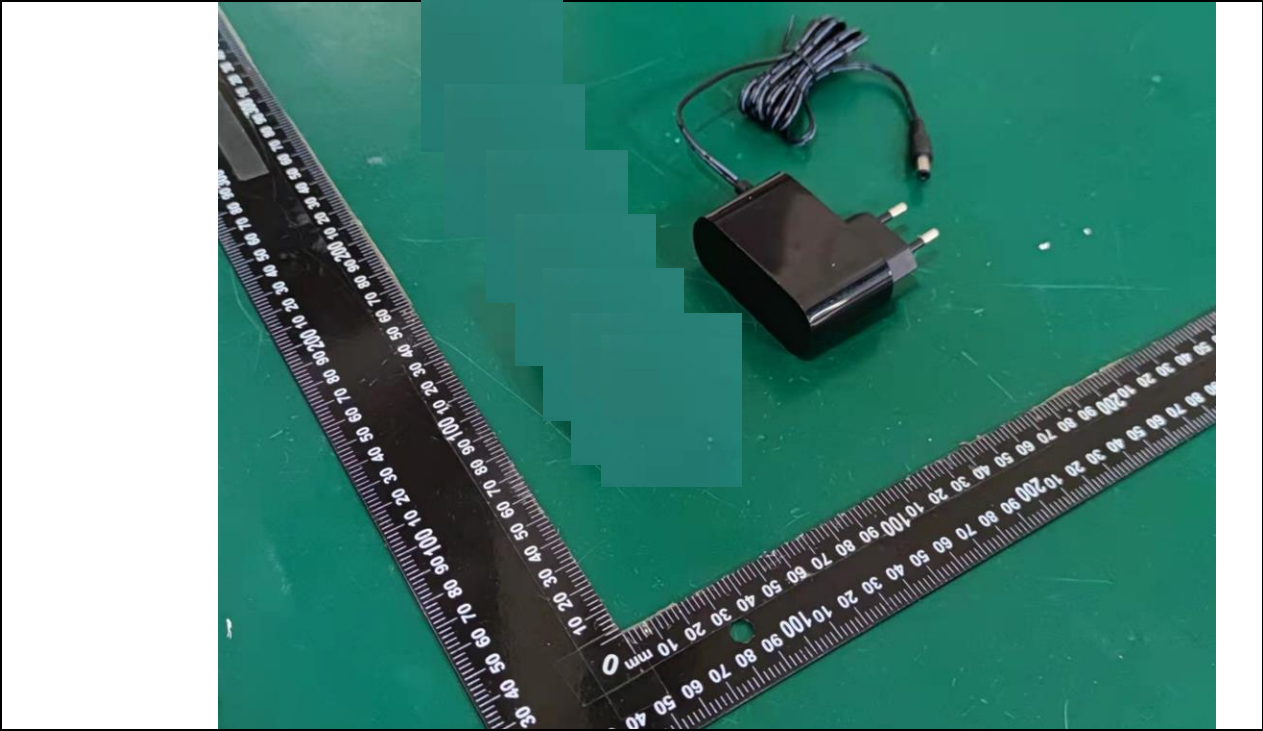

Details of: Overall view-60 (models: CZH015xxxxyyEUWAa)

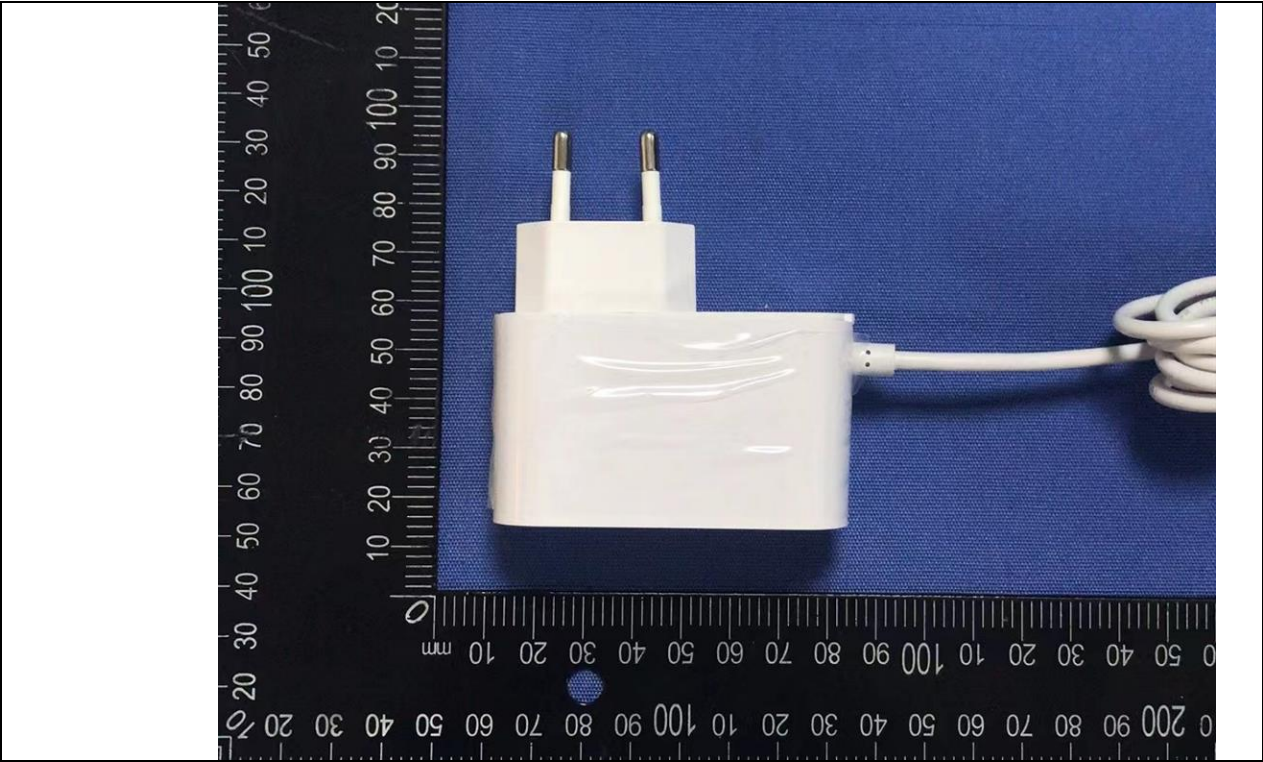

Details of: Overall view-61 (models: CZH015050yyyEUUGa, CZH015050yyyBSUGa)

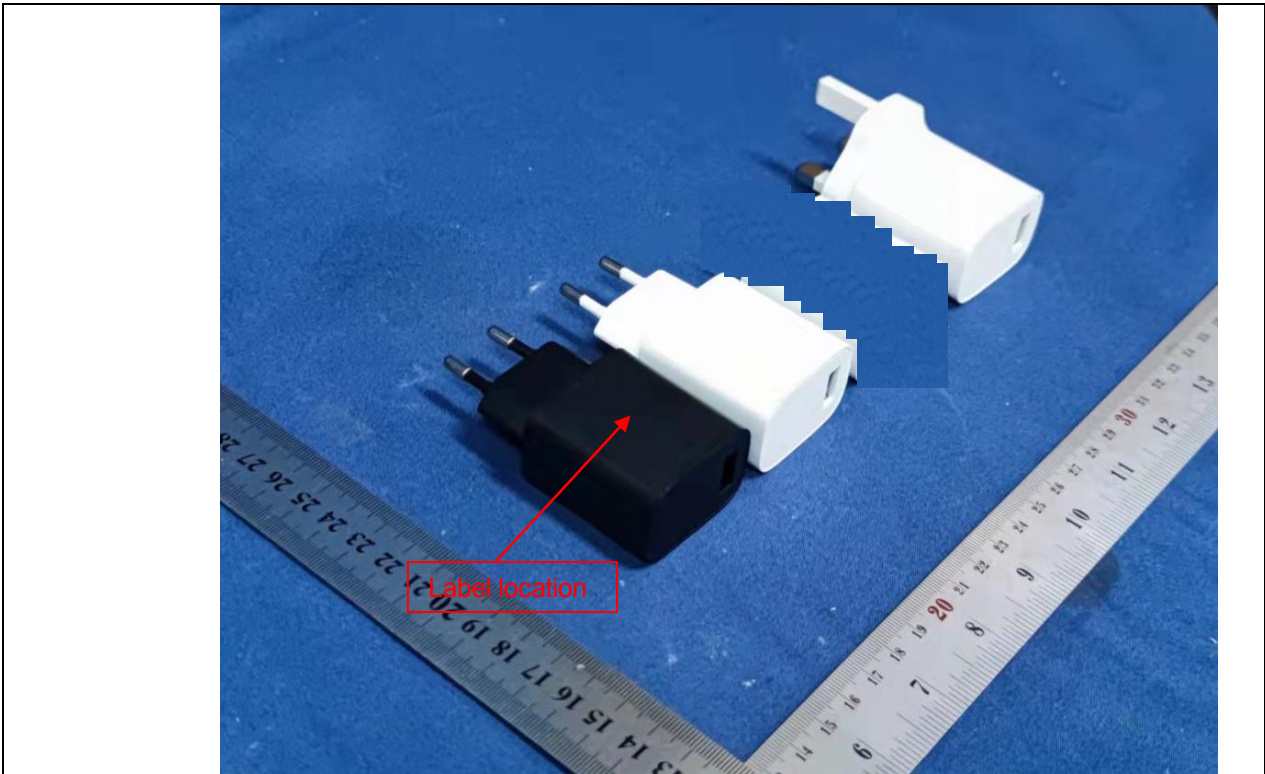

Details of: Overall view-62 (models: CZH015050yyyEUUGa, CZH015050yyyBSUGa)

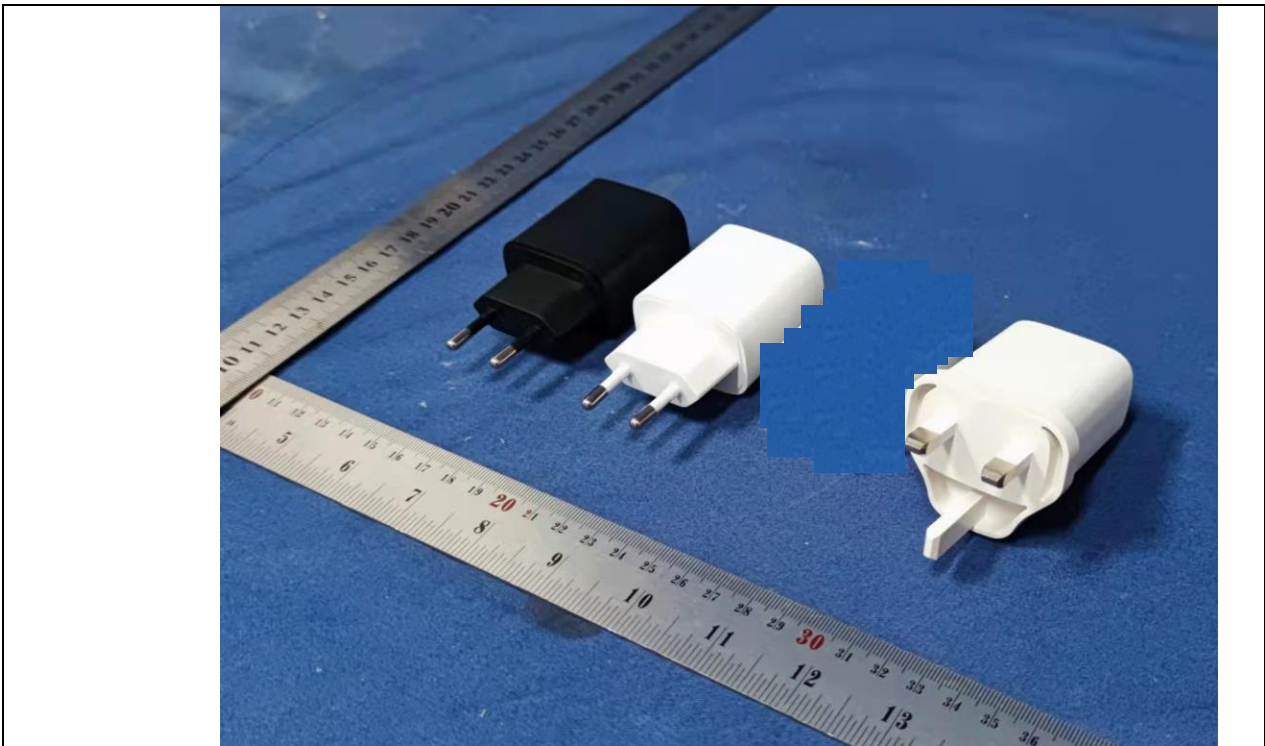

Details of: Internal view-1 (models: CZH015xxxxyyEUWM, CZH015xxxxyyEUWF, without input wire)
(PCB type C)



Details of: Internal view-2 (models: CZH015xxxxyyEUWML, CZH015xxxxyyEUWFL, without input wire)
(PCB type C)



Attachment No. 5

Details of: Internal view-3 (models: CZH015xxxxxyyEUWM, CZH015xxxxxyyEUWF, CZH015xxxxxyyEUWML, CZH015xxxxxyyEUWFL, without input wire) (PCB type C)



Details of: Internal view-4 (models: CZH015xxxxxyyBSWM, CZH015xxxxxyyBSWF, CZH015xxxxxyyBSWML, CZH015xxxxxyyBSWFL, without input wire) (PCB type C)



Attachment No. 5

Details of: Internal view-5 (models: CZH015xxxxyyEUWM, CZH015xxxxyyEUWF, CZH015xxxxyyEUWML, CZH015xxxxyyEUWFL, without input wire)



Details of: Internal view-6 (models: CZH015xxxxyyBSWM, CZH015xxxxyyBSWF, CZH015xxxxyyBSWML, CZH015xxxxyyBSWFL, without input wire)



Details of: Internal view-7 (models: CZH015xxxxyyEUWM, CZH015xxxxyyEUWF, CZH015xxxxyyTRWM, CZH015xxxxyyTRWF, with input wire) (PCB type C)



Details of: Internal view-8 (models: CZH015xxxxyyEUWML, CZH015xxxxyyEUWFL, CZH015xxxxyyTRWML, CZH015xxxxyyTRWFL, with input wire) (PCB type C)



Attachment No. 5

Details of: Internal view-9 (models: CZH015xxxxyyBSWM, CZH015xxxxyyBSWF, with input wire)
(PCB type C)



Details of: Internal view-10 (models: CZH015xxxxyyBSWML, CZH015xxxxyyBSWFL, with input wire)
(PCB type C)



Attachment No. 5

Details of: Internal view-11 (models: CZH015xxxxyyEUWM, CZH015xxxxyyEUWF, CZH015xxxxyyEUWML, CZH015xxxxyyEUWFL, with input wire)



Details of: Internal view-12 (models: CZH015xxxxyyBSWM, CZH015xxxxyyBSWF, CZH015xxxxyyBSWML, CZH015xxxxyyBSWFL, CZH015050yyyBSUM, with input wire)



Attachment No. 5

Details of: Internal view-13 (models: CZH015xxxxyyEUWM, CZH015xxxxyyEUWF, CZH015xxxxyyEUWML, CZH015xxxxyyEUWFL, with input wire)

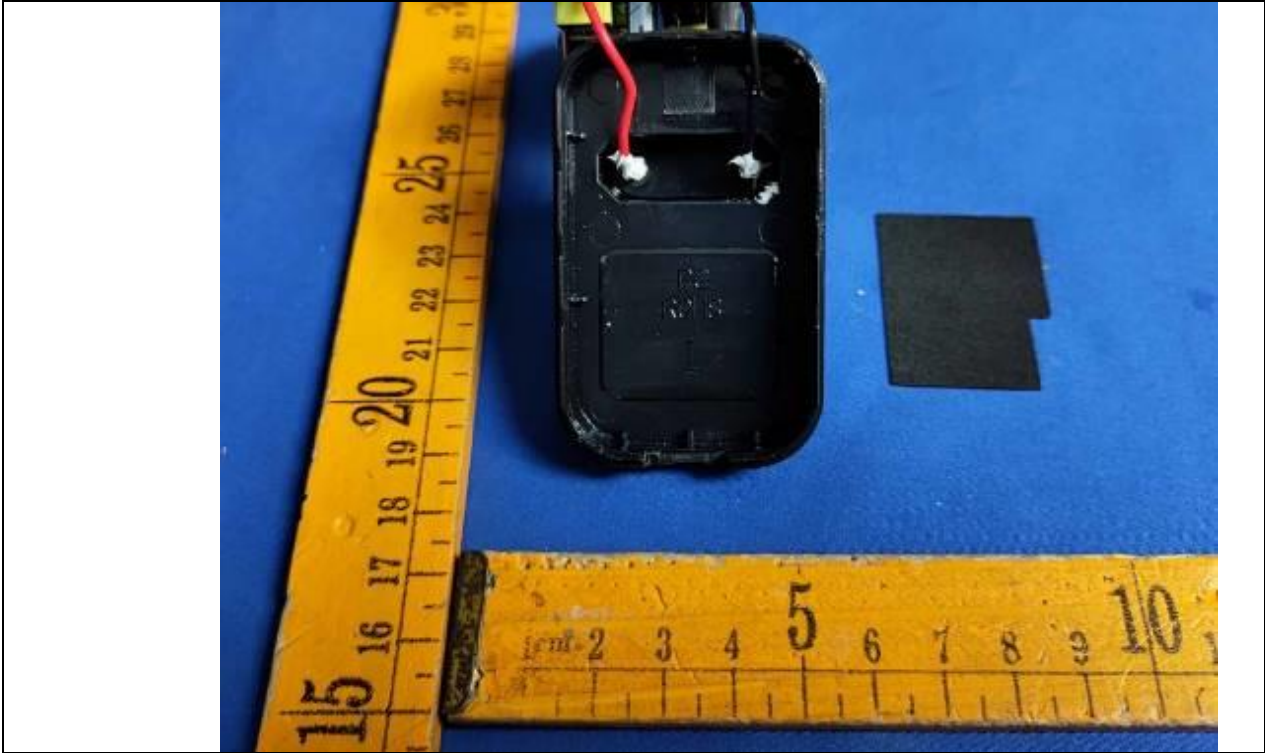

Details of: Internal view-14 (models: CZH015xxxxyyymmWMLG, CZH015xxxxyyymmWFLG, without input wire) (PCB type C)



Details of: Internal view-15 (models: CZH015xxxxyyymmWMG, CZH015xxxxyyymmWFG, without input wire) (PCB type C)



Details of: Internal view-16 (models: CZH015xxxxyyymmWMG, CZH015xxxxyyymmWFG, with input wire) (PCB type C)



Details of: Internal view-17 (models: CZH015xxxxyyymmWMLG, CZH015xxxxyyymmWFLG, with input wire) (PCB type C)



Details of: Internal view-18 (models: CZH015xxxxyyEUWH, CZH015xxxxyyEUWP, without input wire) (PCB type B)



Attachment No. 5

Details of: Internal view-19 (models: CZH015xxxxyyEUWHL, CZH015xxxxyyEUWPL, without input wire) (PCB type B)



Details of: Internal view-20 (models: CZH015xxxxyyEUWHL, CZH015xxxxyyEUWPL, without input wire) (PCB type B)

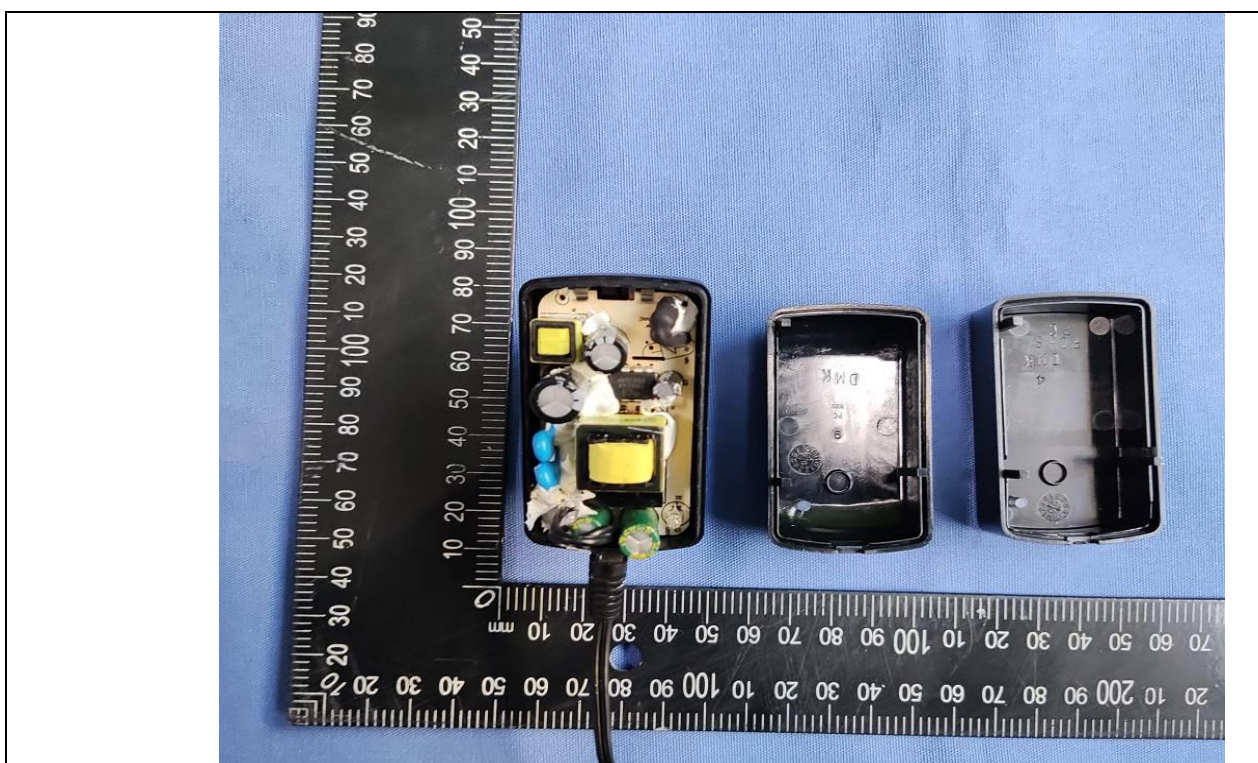

Attachment No. 5

Details of: Internal view-21 (models: CZH015xxxxyyBSWHL, CZH015xxxxyyBSWPL, without input wire) (PCB type B)



Details of: Internal view-22 (models: CZH015xxxxyyEUWH, CZH015xxxxyyEUWP, without input wire) (PCB type B)

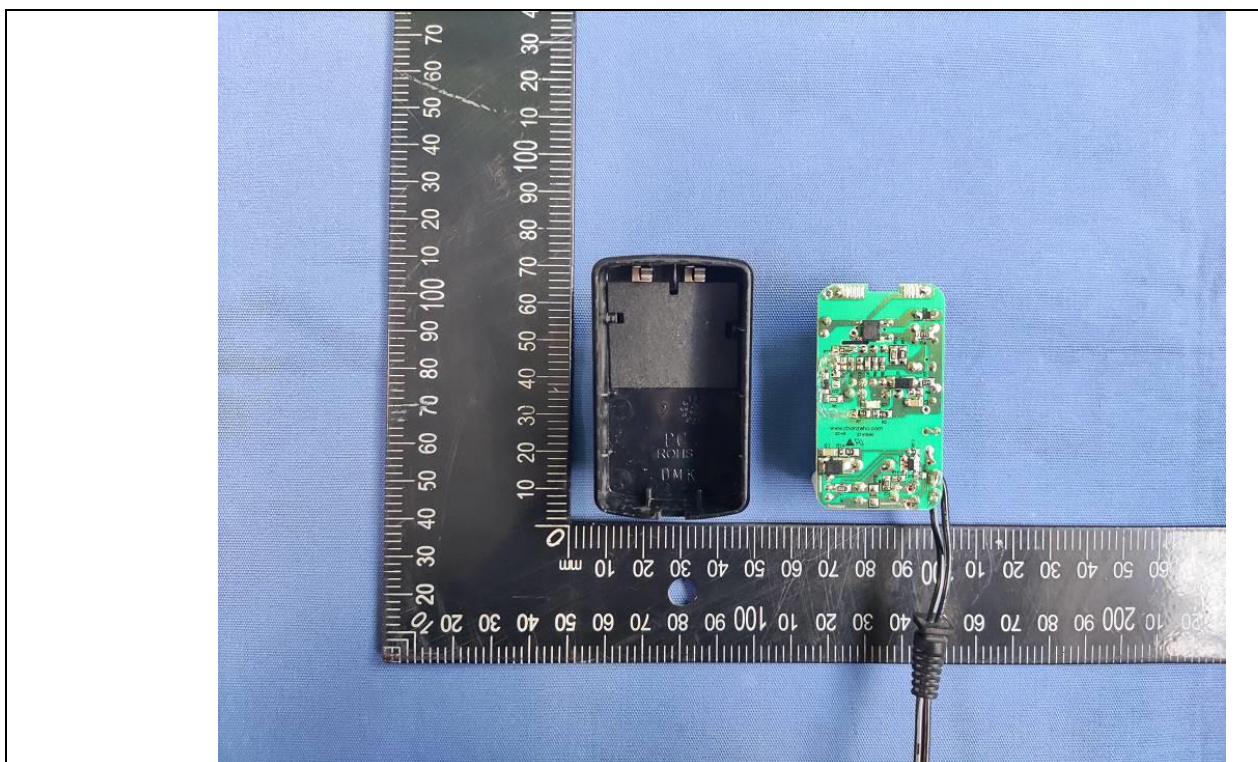

Details of: Internal view-23 (CZH015xxxxyyEUWH, CZH015xxxxyyEUWP, without input wire) (PCB type A)



Details of: Internal view-24 (CZH015xxxxyyBSWH, CZH015xxxxyyBSWP, without input wire) (PCB type A)



Details of: Internal view-25 (CZH015xxxxyyEUWH, CZH015xxxxyyEUWP, without input wire) (PCB type A)



Details of: Internal view-26 (models: CZH015xxxxyyEUWH, CZH015xxxxyyEUWP, without input wire)



Details of: Internal view-27 (models: CZH015xxxxyyBSWH, CZH015xxxxyyBSWP, without input wire)

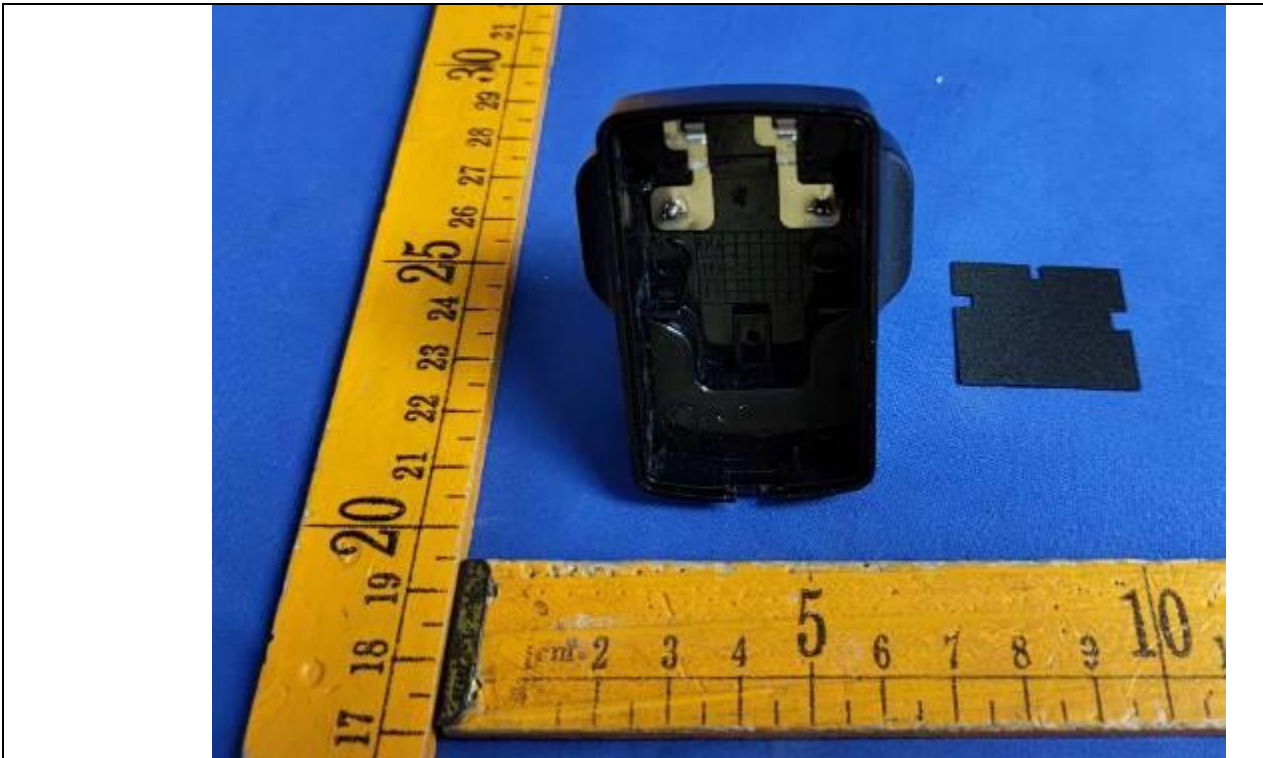

Details of: Internal view-28 (models: CZH015xxxxyyEUWH, CZH015xxxxyyEUWP, with input wire) (PCB type B)



Details of: Internal view-29 (models: CZH015xxxxyyEUWHL, CZH015xxxxyyEUWPL, with input wire)

(PCB type B)



Details of: Internal view-30 (models: CZH015xxxxyyBSWHL, CZH015xxxxyyBSWPL, with input wire)
(PCB type B)



Details of: Internal view-31 (models: CZH015xxxxyyBSWH, CZH015xxxxyyBSWP, with input wire)

(PCB type A)

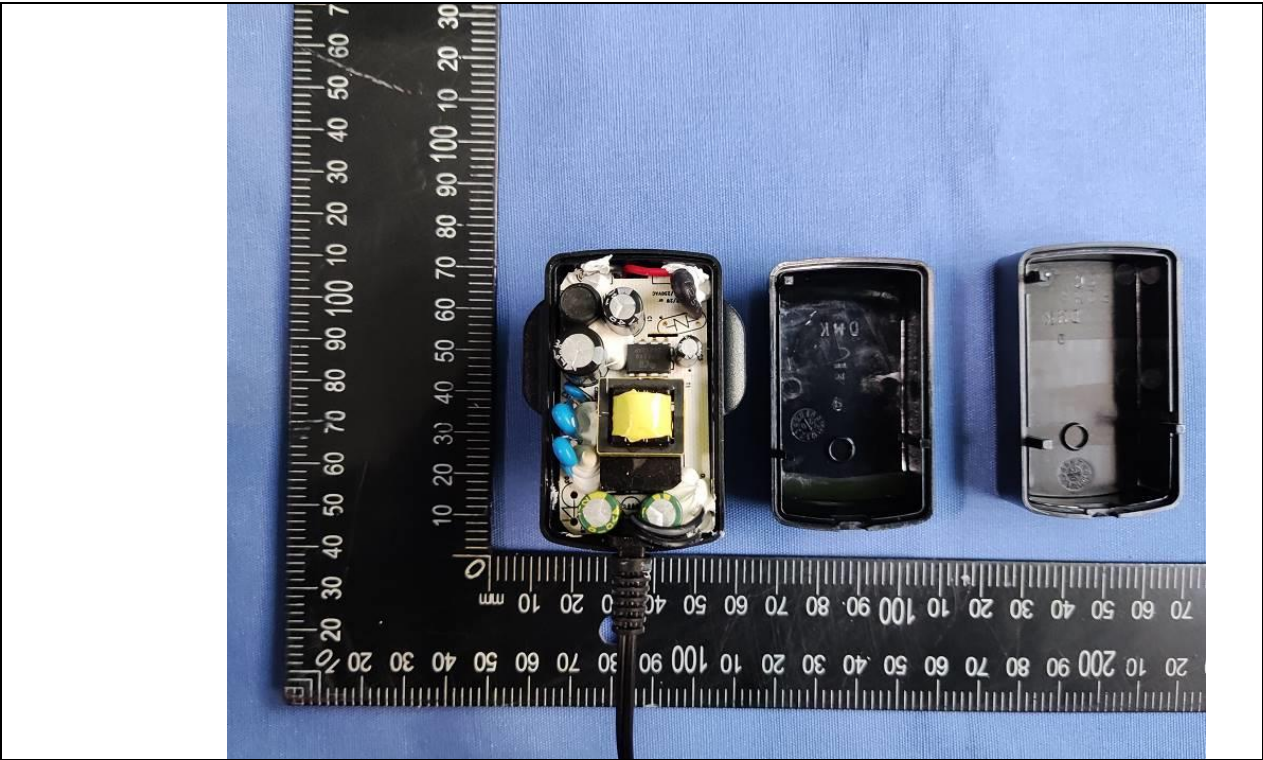

Details of: Internal view-32 (models: CZH015xxxxxyyEUWH, CZH015xxxxxyyEUWP, with input wire)
(PCB type A)



Details of: Internal view-33 (models: CZH015xxxxyyEUWH, CZH015xxxxyyEUWP, with input wire)



Details of: Internal view-34 (models: CZH015xxxxyyEUWH, CZH015xxxxyyEUWP, with input wire)



Details of: Internal view-35 (models: CZH015xxxxyyBSWH, CZH015xxxxyyBSWP, with input wire)

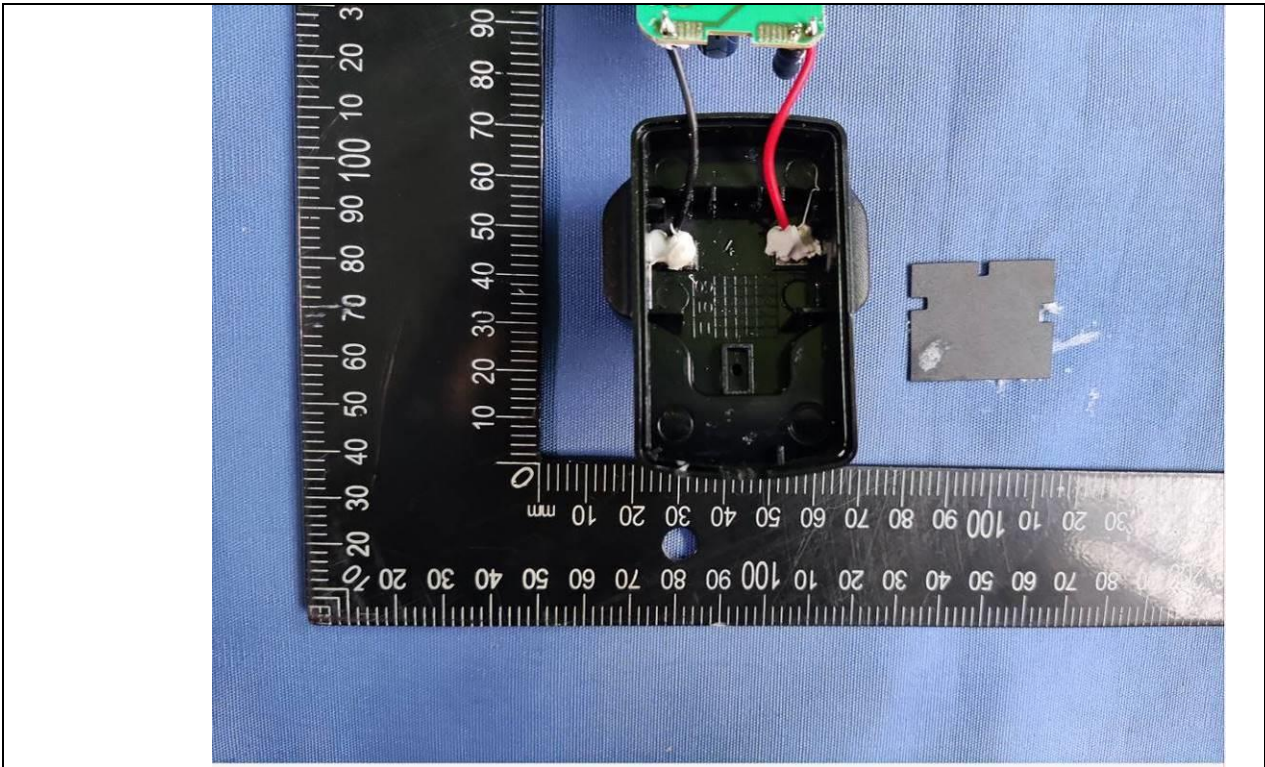

Details of: Internal view-36 (models: CZH015xxxxyyEUWHG, CZH015xxxxyyEUWPG) (PCB type B)



Details of: Internal view-37 (models: CZH015xxxxyyEUWHLG, CZH015xxxxyyEUWPLG) (PCB type B)



Details of: Internal view-38 (models: CZH015xxxxyyymmWHG, CZH015xxxxyyymmWPG, with input wire) (PCB type A)



Details of: Internal view-39 (models: CZH015050yyyEUUM, without input wire) (PCB type D)



Details of: Internal view-40 (models: CZH015050yyyEUUM, without input wire) (PCB type D)



Details of: Internal view-41 (models: CZH015050yyyBSUM, without input wire) (PCB type D)



Details of: Internal view-42 (models: CZH015050yyyBSUM, without input wire) (PCB type D)



Details of: Internal view-43 (models: CZH015050yyyEUUM, , without input wire)



Details of: Internal view-44 (models: CZH015050yyyBSUM, without input wire)



Details of: Internal view-45 (models: CZH015050yyyEUUM, with input wire) (PCB type D)



Details of: Internal view-46 (models: CZH015050yyyBSUM, with input wire) (PCB type D)



Details of: Internal view-47 (models: CZH015050yyyBSUM, with input wire) (PCB type D)



Details of: Internal view-48 (models: CZH015050yyyEUUM, with input wire) (PCB type D)



Details of: Internal view-49 (models: CZH015050yyyEUUM, with input wire)



Details of: Internal view-50 (models: CZH015xxxxyyTRWM, CZH015xxxxyyTRWF, CZH015xxxxyyTRWML, CZH015xxxxyyTRWFL, with input wire)



Details of: Internal view-51 (models: CZH015xxxxyyTRWM, CZH015xxxxyyTRWF, CZH015xxxxyyTRWML, CZH015xxxxyyTRWFL, with input wire)



Details of: Internal view-52 (models: CZH015xxxxyyEUWQ) (PCB type A)



Details of: Internal view-53 (models: CZH015xxxxyyEUWQ) (PCB type A)

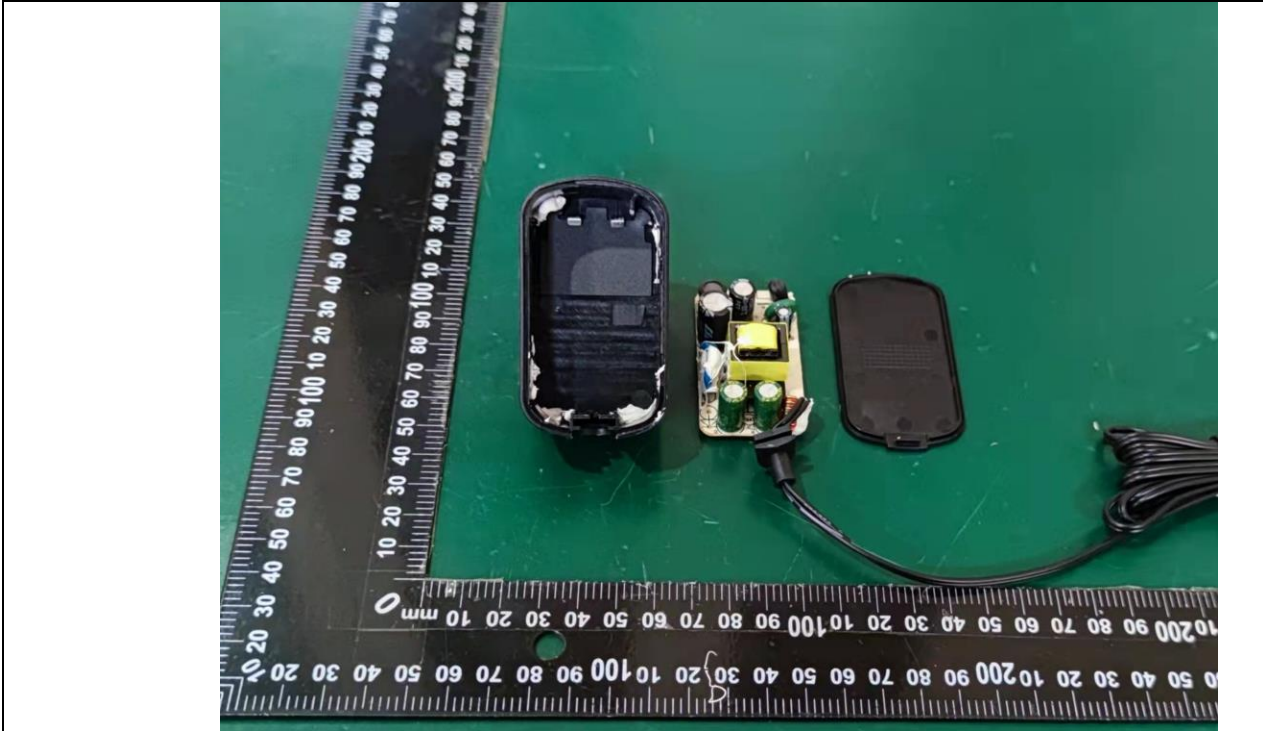

Details of: Internal view-54 (models: CZH015xxxxyyEUWQ) (PCB type A)

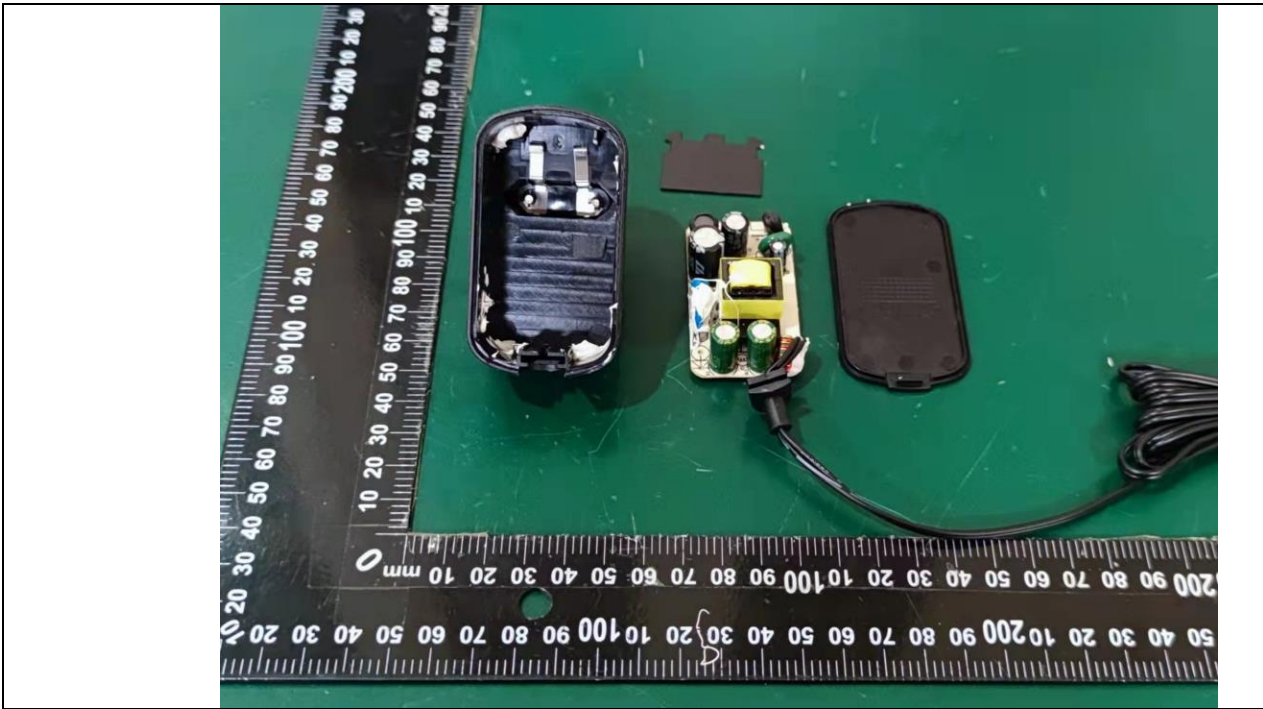

Details of: Internal view-55 (models: CZH015xxxxyyBSWQ) (PCB type A)

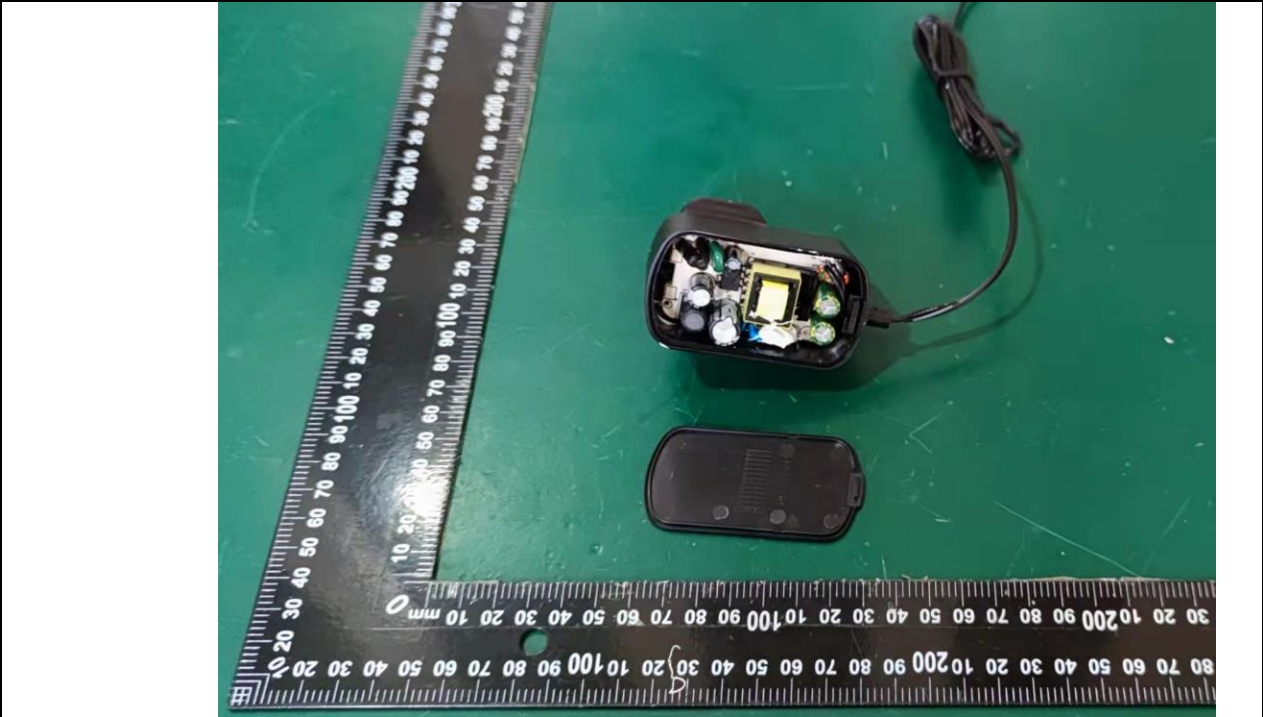

Details of: Internal view-56 (models: CZH015xxxxyyBSWQ) (PCB type A)



Details of: Internal view-57 (models: CZH015xxxxyyBSWQ) (PCB type A)



Details of: Internal view-58 (models: CZH015xxxxyyEUWQLG) (PCB type A)



Details of: Internal view-59 (models: CZH015xxxxyyTRWQ) (PCB type A)

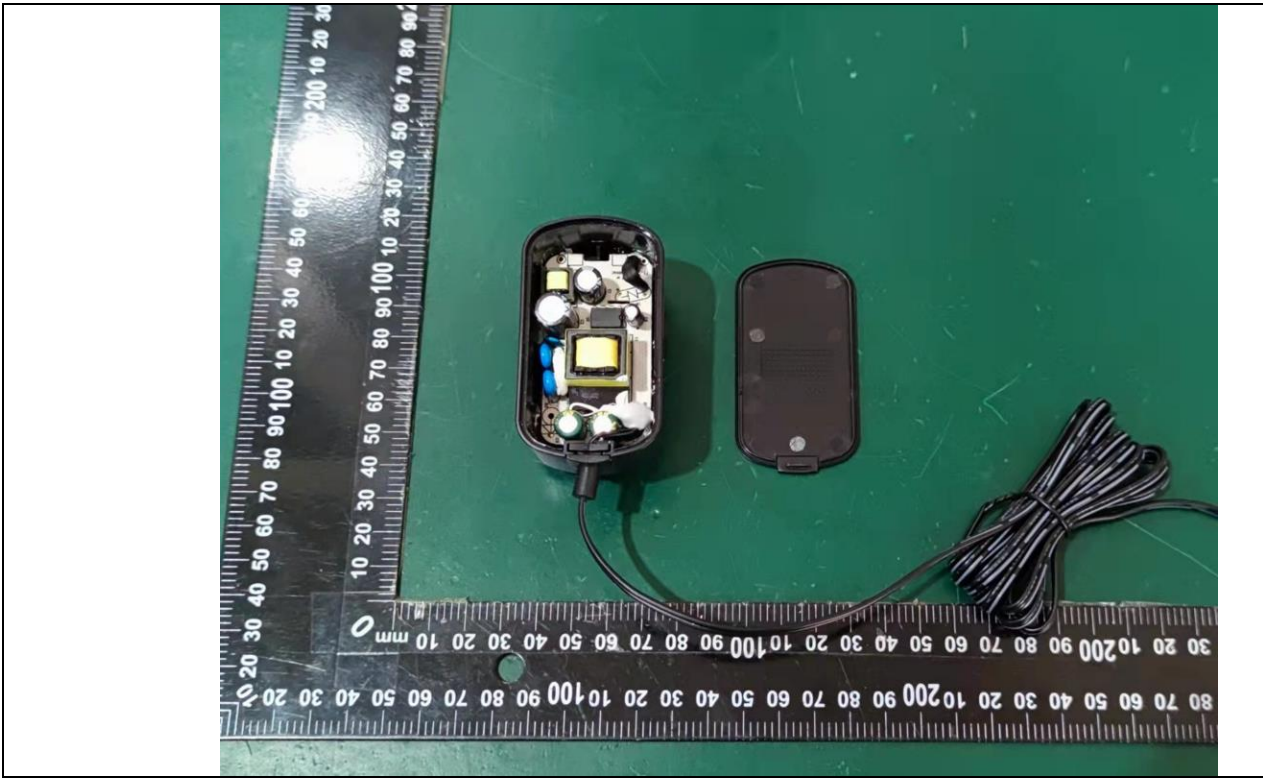

Details of: Internal view-60 (models: CZH015xxxxyyTRWQ) (PCB type A)



Details of: Internal view-61 (models: CZH015xxxxyyTRWQ) (PCB type A)



Details of: Internal view-62 (models: CZH015xxxxyyTRWQL) (PCB type A)



Details of: Internal view-63 (models: CZH015xxxxyyEUWAa) (PCB type E)



Details of: Internal view-64 (models: CZH015xxxxyyEUWAa) (PCB type E)



Details of: Internal view-65 (models: CZH015050yyyEUUGa) (PCB type F)



Details of: Internal view-66 (models: CZH015050yyyEUUGa) (PCB type F)

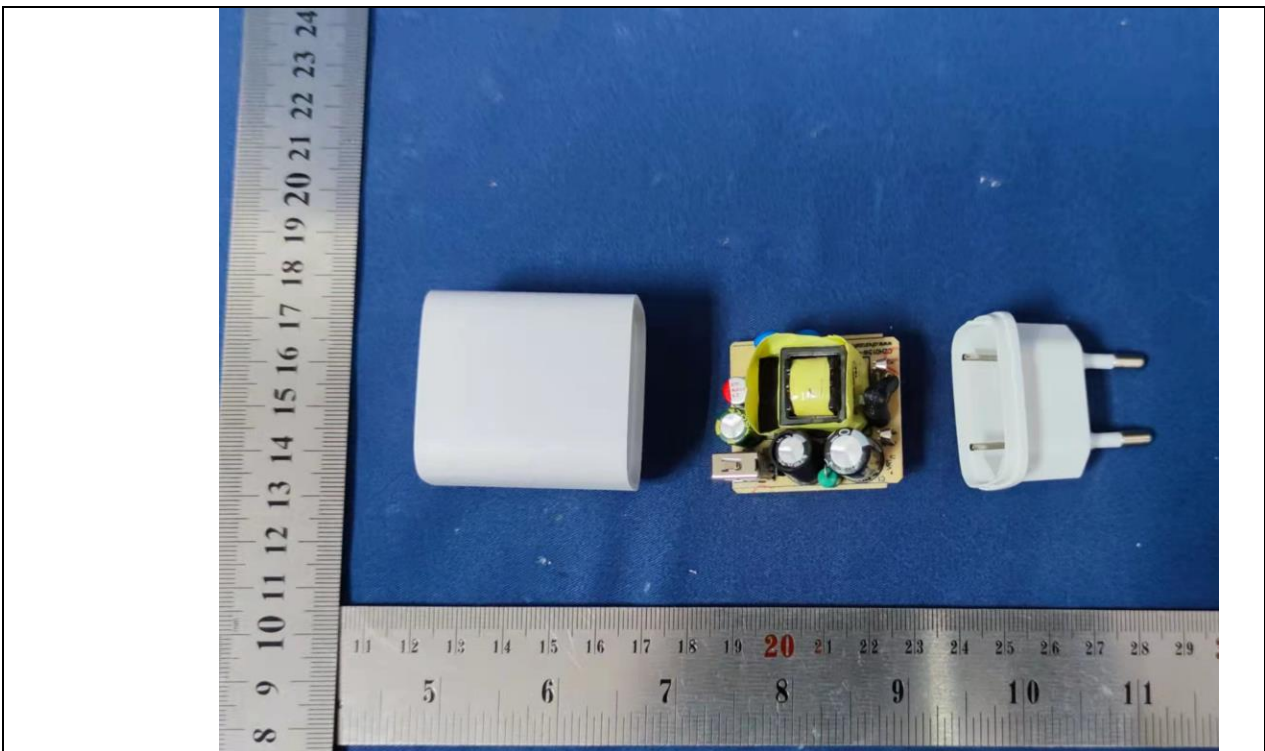

Details of: Internal view-67 (models: CZH015050yyyBSUGa) (PCB type F)

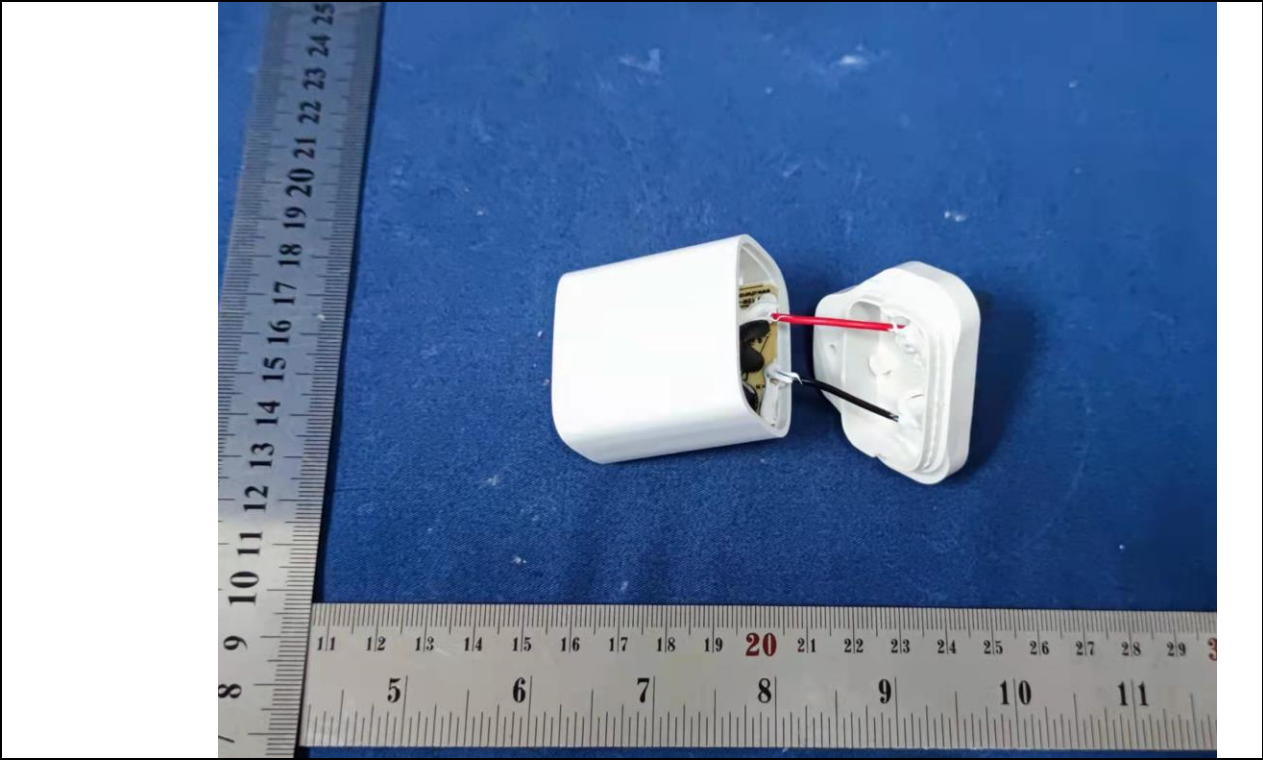

Details of: Internal view-68 (models: CZH015050yyyBSUGa) (PCB type F)

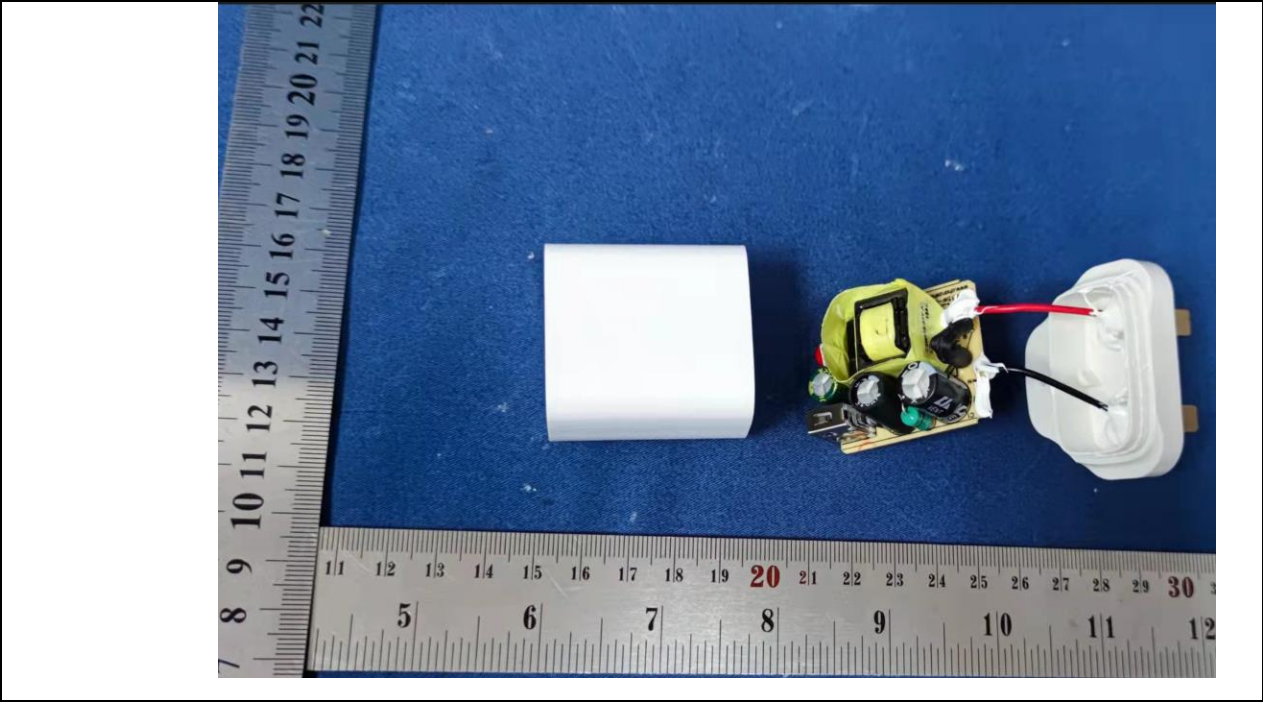

Details of: Internal view-69, (models: CZH015xxxxyyymmWM, CZH015xxxxyyymmWF) (PCB type G)



Details of: Internal view-70, Back view for all types of insulation sheet

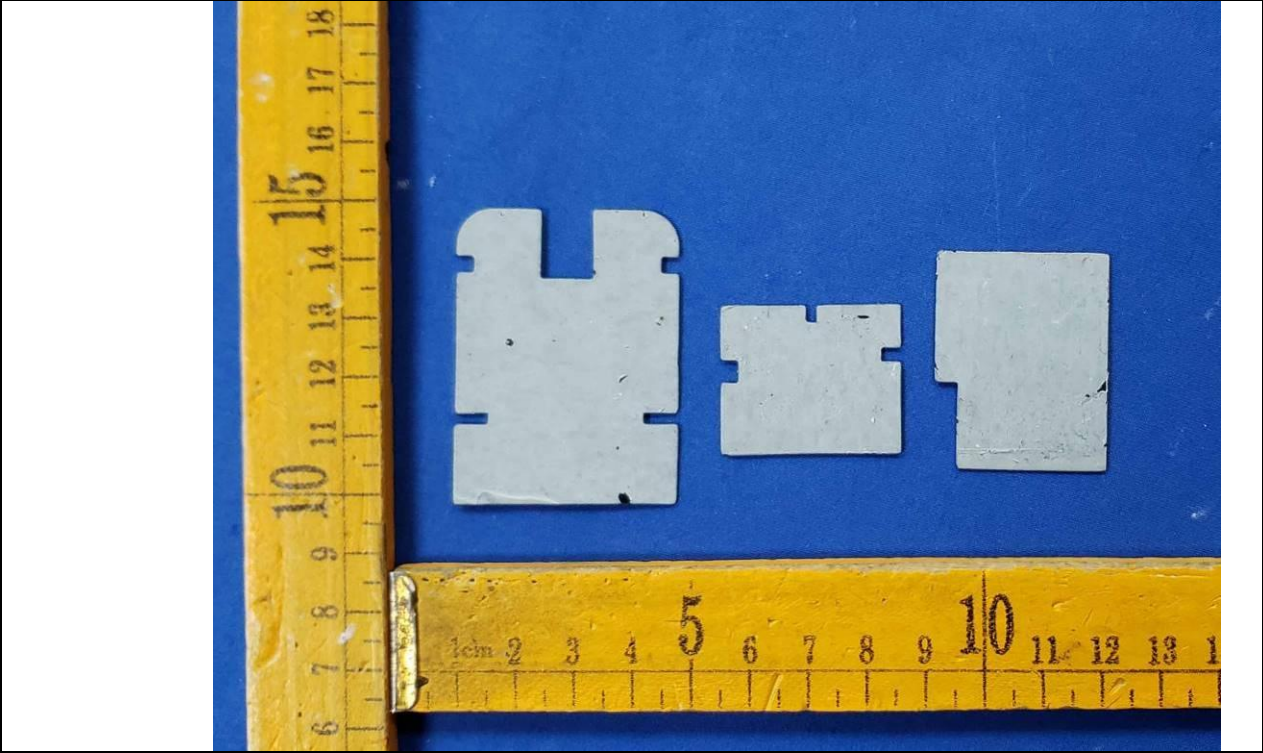

Details of: PCB component view-1 (models: CZH015xxxxyyymmWML, CZH015xxxxyyymmWFL) (With L1, VR1, CY1, CY2, LF2, LED1 used, without LF1, C3A) (PCB type C)



Details of: PCB component view-2 (models: CZH015xxxxyyymmWML, CZH015xxxxyyymmWFL) (With L1, VR1, CY1, CY2, LF2, LED1 used, without LF1, C3A) (PCB type C)

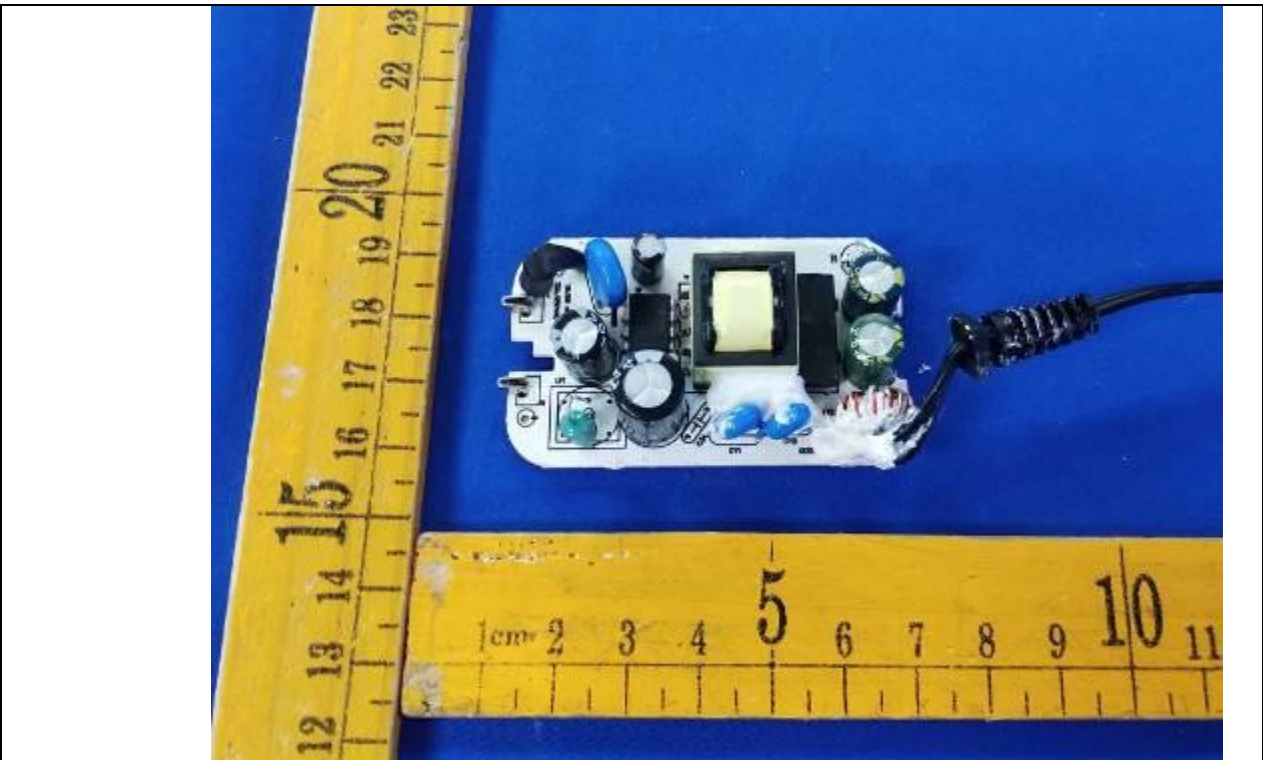

Details of: PCB component view-3 (models: CZH015xxxxyymmWML, CZH015xxxxyymmWFL) (With LF1, VR1, CY1, CY2, LF2, LED1 used, without L1, C3A) (PCB type C)



Details of: PCB component view-4 (models: CZH015xxxxyymmWML, CZH015xxxxyymmWFL) (With L1, CY1, CY2, LF2, LED1 used, without LF1, C3A, VR1) (PCB type C)



Details of: PCB component view-5 (models: CZH015xxxxyymmWML, CZH015xxxxyymmWFL) (With L1, CY1, CY2, LF2, LED1 used, without LF1, C3A, VR1) (PCB type C)



Details of: PCB component view-6 (models: CZH015xxxxyymmWML, CZH015xxxxyymmWFL) (With LF1, CY1, CY2, LF2, LED1 used, without L1, C3A, VR1) (PCB type C)



Attachment No. 5

Details of: PCB component view-7 (models: CZH015xxxxyymmWML, CZH015xxxxyymmWFL) (With L1, CY1, CY2, LED1 used, without LF1, C3A, VR1, LF2) (PCB type C)

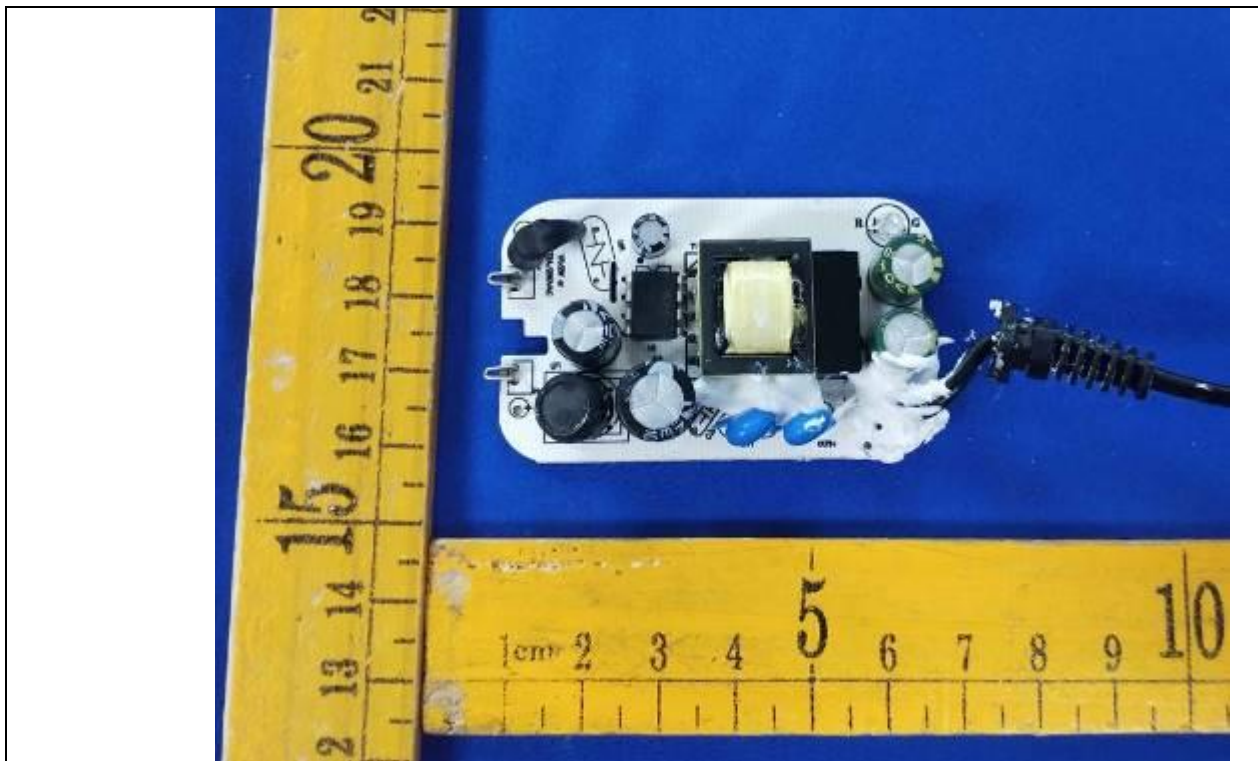

Details of: PCB component view-8 (models: CZH015xxxxyymmWM, CZH015xxxxyymmWF) (With L1, CY1, CY2 used, without LF1, C3A, VR1, LF2, LED1) (PCB type C)

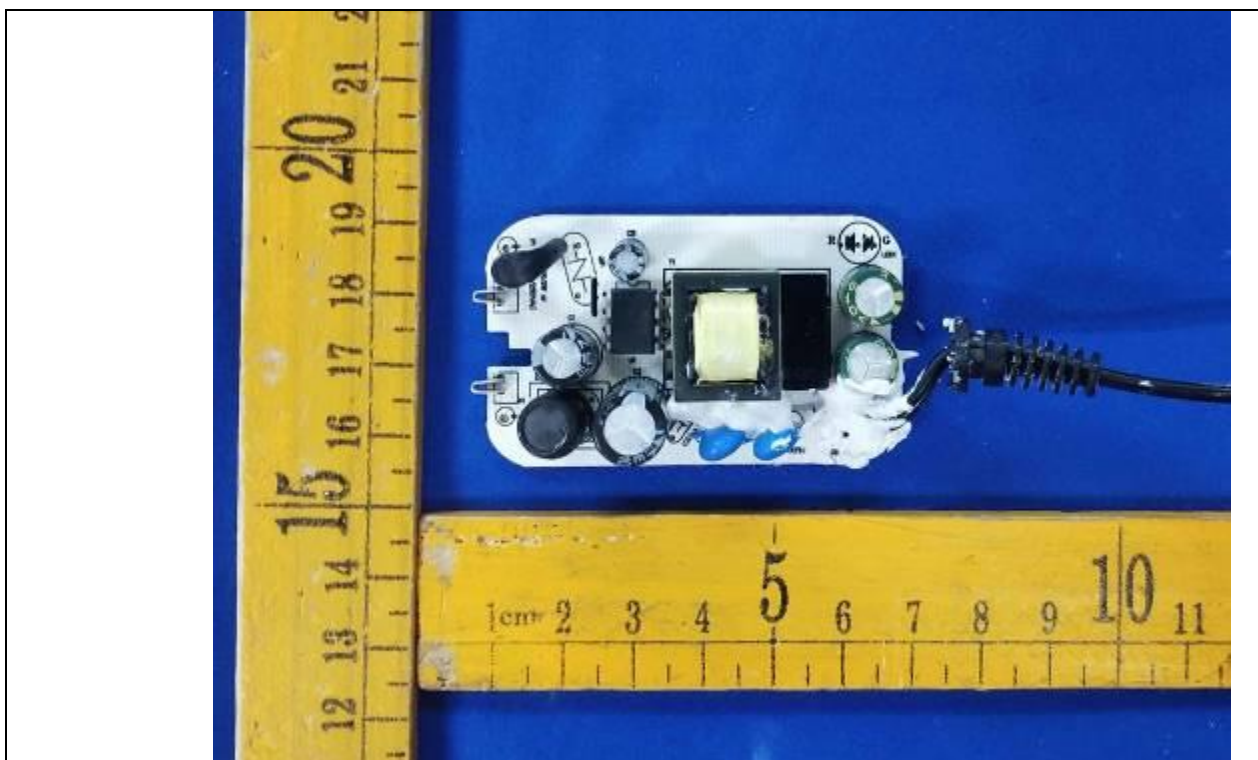

Details of: PCB component view-9 (models: CZH015xxxxyymmWM, CZH015xxxxyymmWF) (With L1, CY1, CY2 used, without LF1, C3A, VR1, LF2, LED1, C11) (PCB type C)

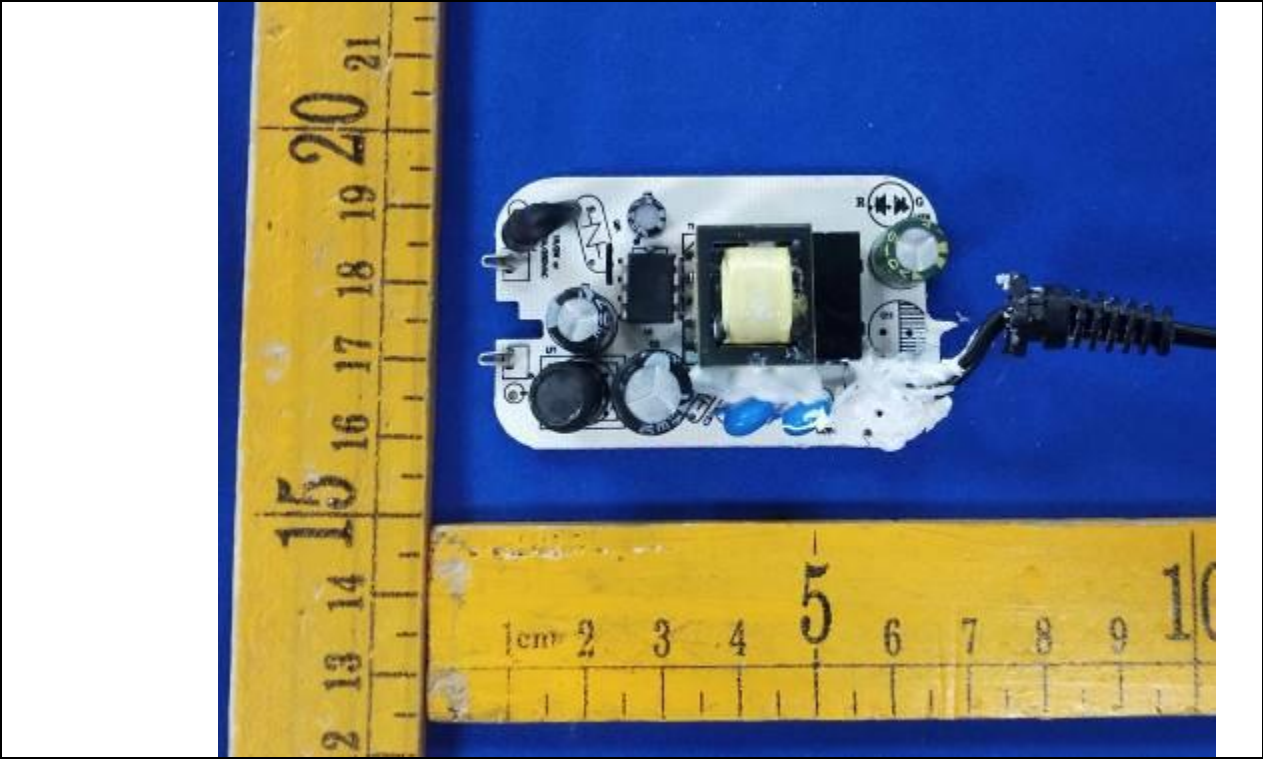

Details of: PCB component view-10 (models: CZH015xxxxyymmWM, CZH015xxxxyymmWF) (With L1, CY3 used, without LF1, C3A, VR1, LF2, LED1, C11) (PCB type C)



Details of: PCB component view-11 (models: CZH015xxxxyyymmWM, CZH015xxxxyyymmWF) (With LF1, CY1, CY2, C3A, LF2 used) (PCB type G)

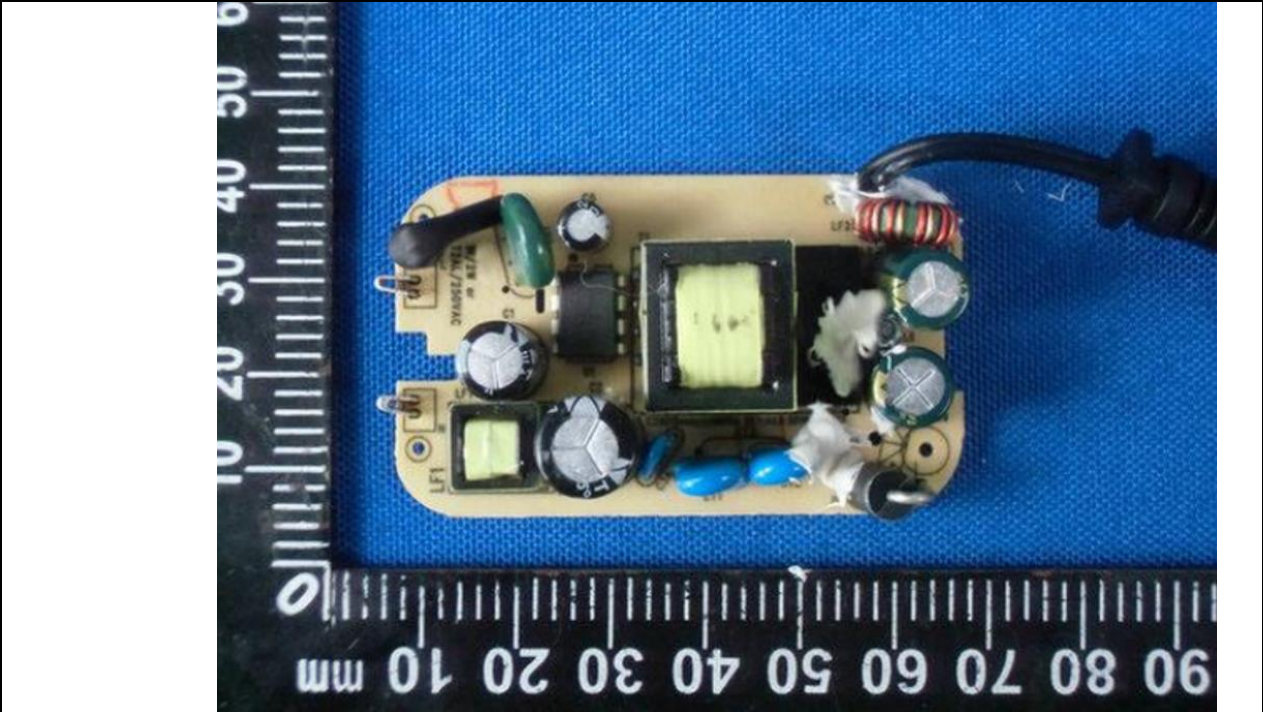

Details of: PCB component view-12 (models: CZH015xxxxyyymmWM, CZH015xxxxyyymmWF) (With LF1, CY3 used) (PCB type G)

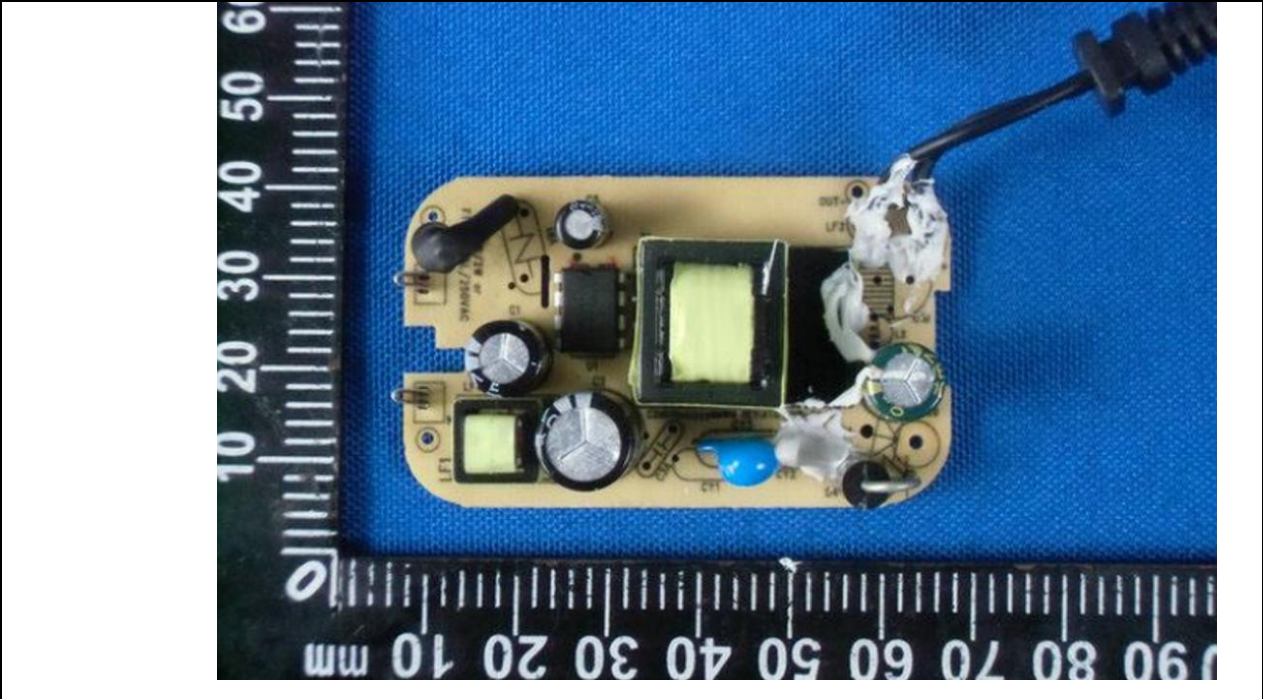

Attachment No. 5

Details of: PCB trace view-13 (models: CZH015xxxxyyymmWM, CZH015xxxxyyymmWF, CZH015xxxxyyymmWML, CZH015xxxxyyymmWFL) (With R12, R5, R9, R16, R17, R19, ZD1, R13 used, without C4, C12, C6, ZD2) (PCB type C)

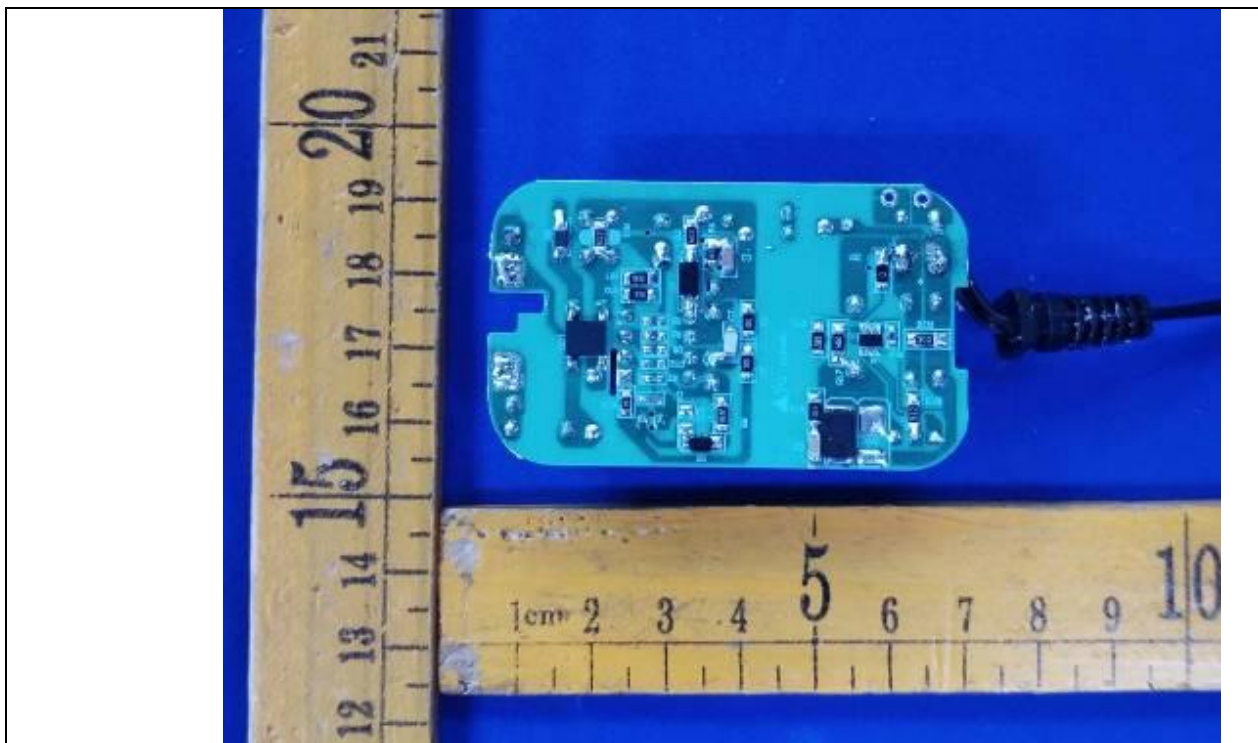

Details of: PCB component view-14 (models: CZH015xxxxyyymmWM, CZH015xxxxyyymmWF) (LF1, CY3 used) (PCB type G)

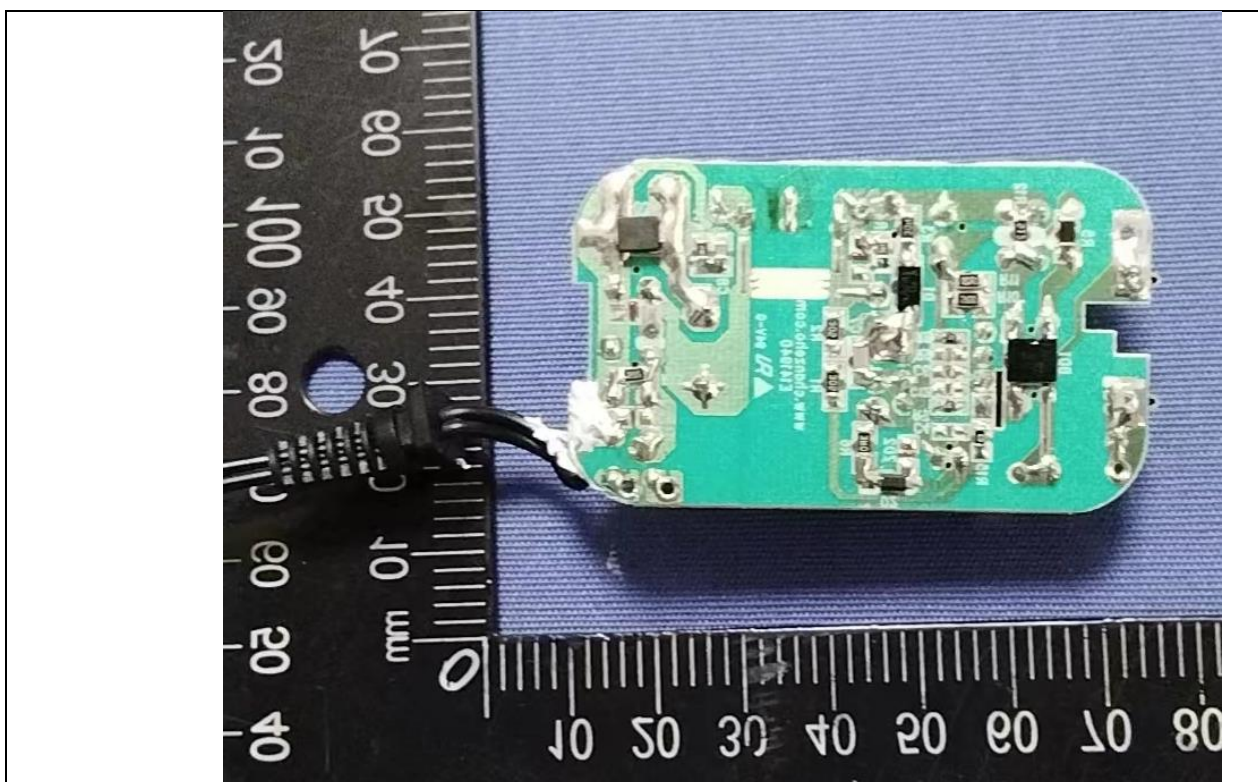

Details of: PCB component view-15 (models: CZH015050yyymmUM) (With L1, CY1, CY2 used, without LF1, C3A, VR1) (PCB type D)



Details of: PCB component view-16 (models: CZH015050yyymmUM) (With L1, CY1, CY2, VR1 used, without LF1, C3A) (PCB type D)

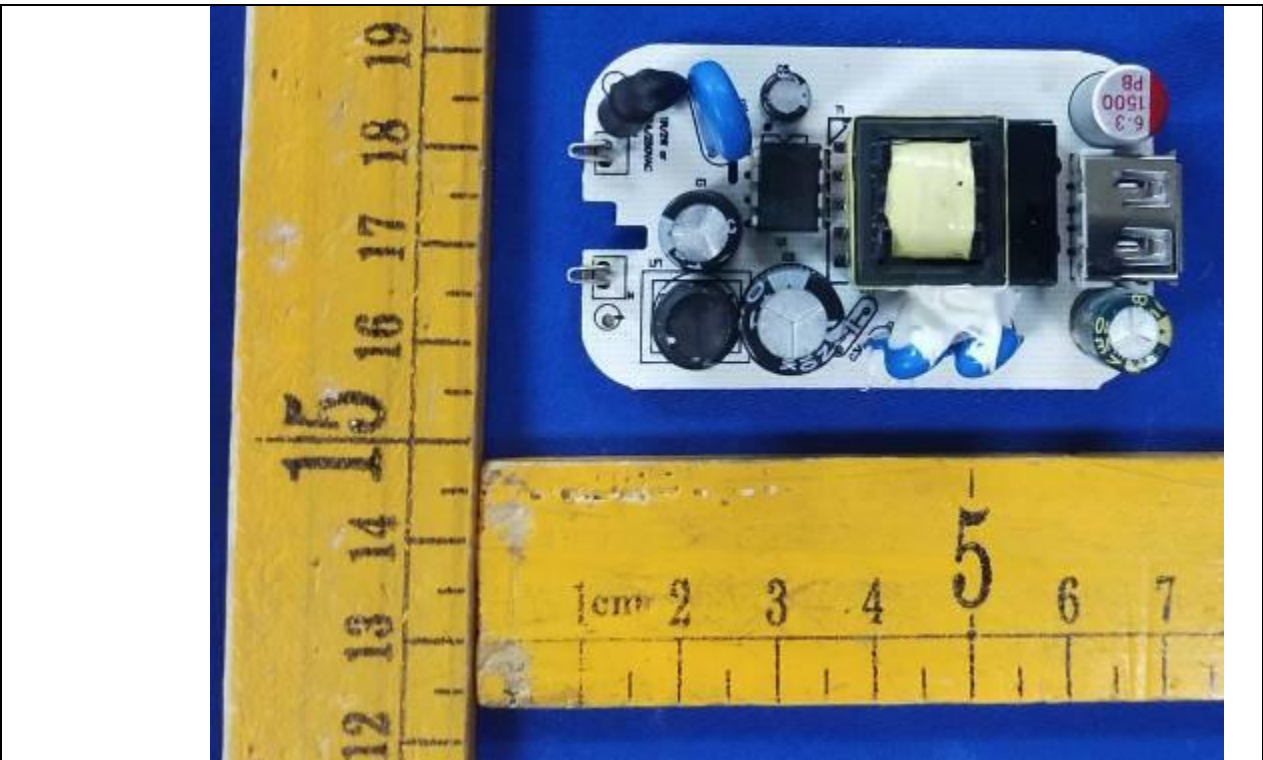

Details of: PCB component view-17 (models: CZH015050yyymmUM) (With L1, CY1, CY2 used, without LF1, C3A, VR1) (PCB type D)

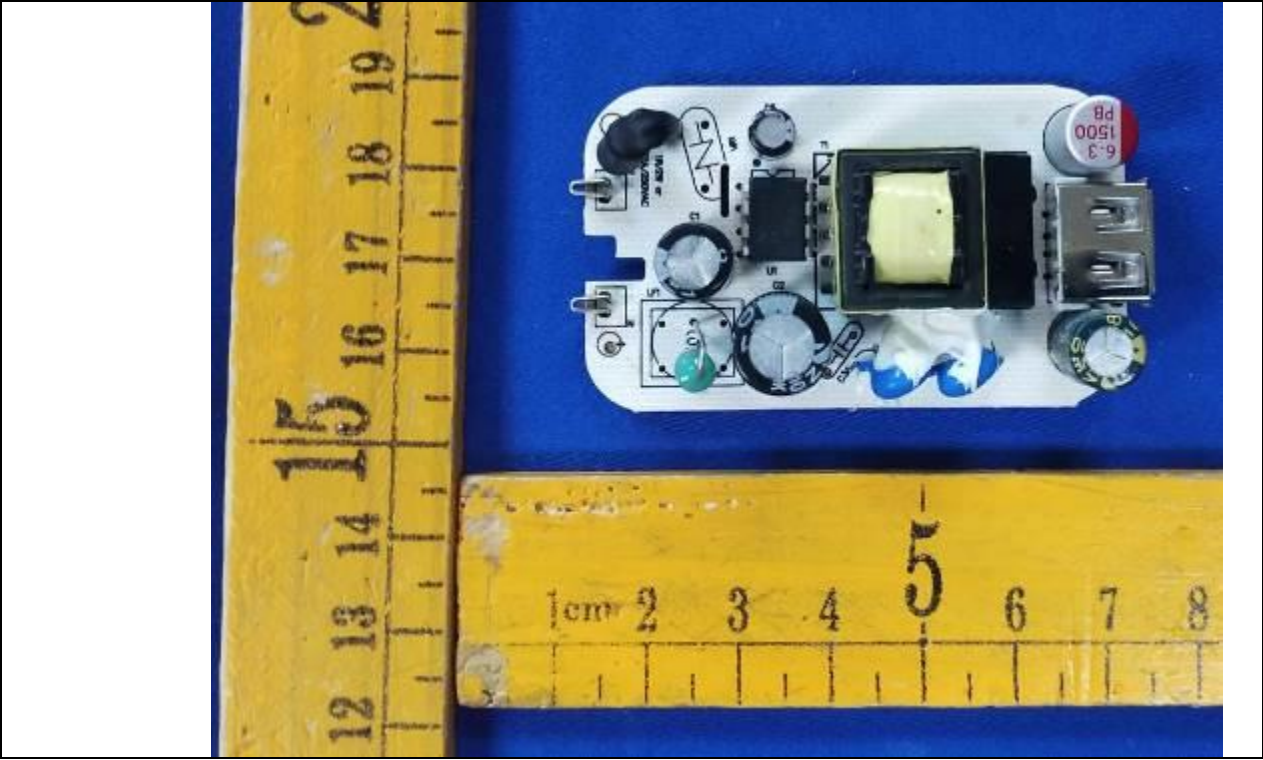

Details of: PCB component view-18 (models: CZH015050yyymmUM) (With LF1, CY1, CY2 used, without L1, C3A, VR1) (PCB type D)



Details of: PCB component view-19 (models: CZH015050yyymmUM) (With L1, CY1, CY2 used, without LF1, C3A, VR1, C10) (PCB type D)

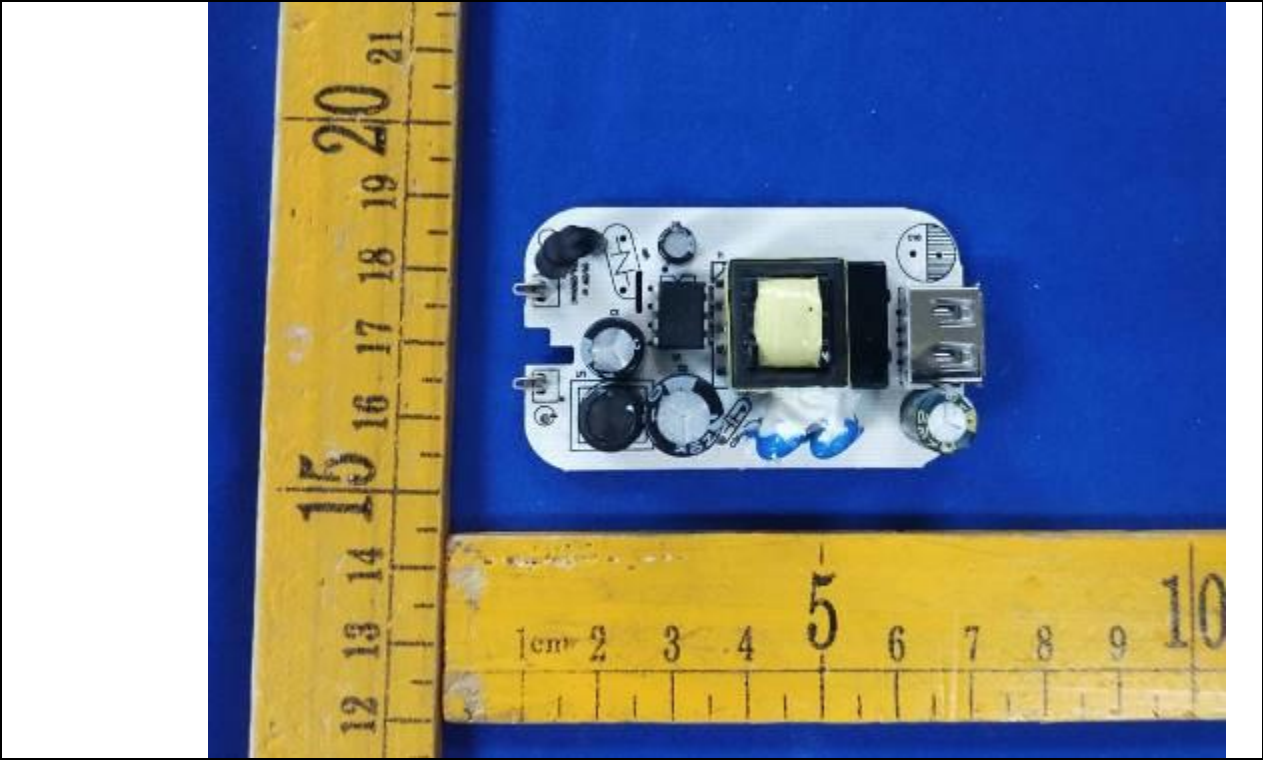

Details of: PCB component view-20 (models: CZH015050yyymmUM) (With L1, CY3 used, without LF1, VR1) (PCB type D)

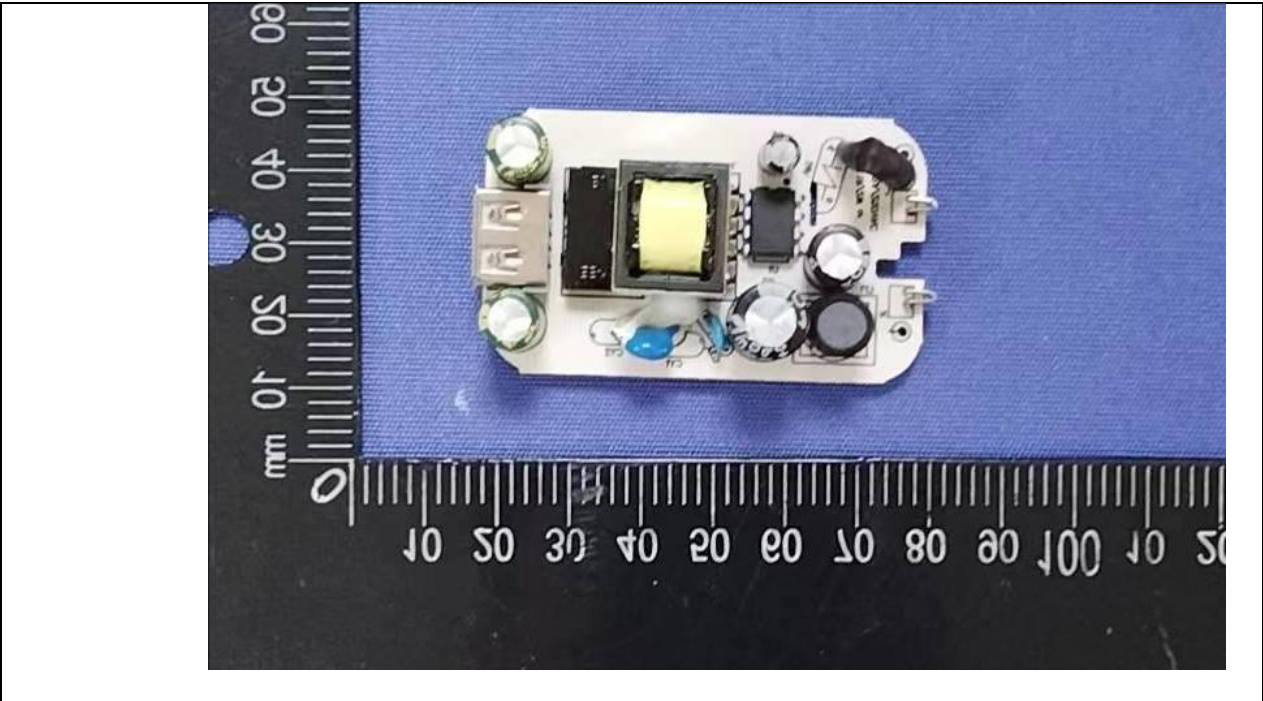

Details of: PCB trace view-21 (models: CZH015050yyymmUM) (With R12, R5, R9 used, without C4, C12, C6, ZD2) (PCB type D)

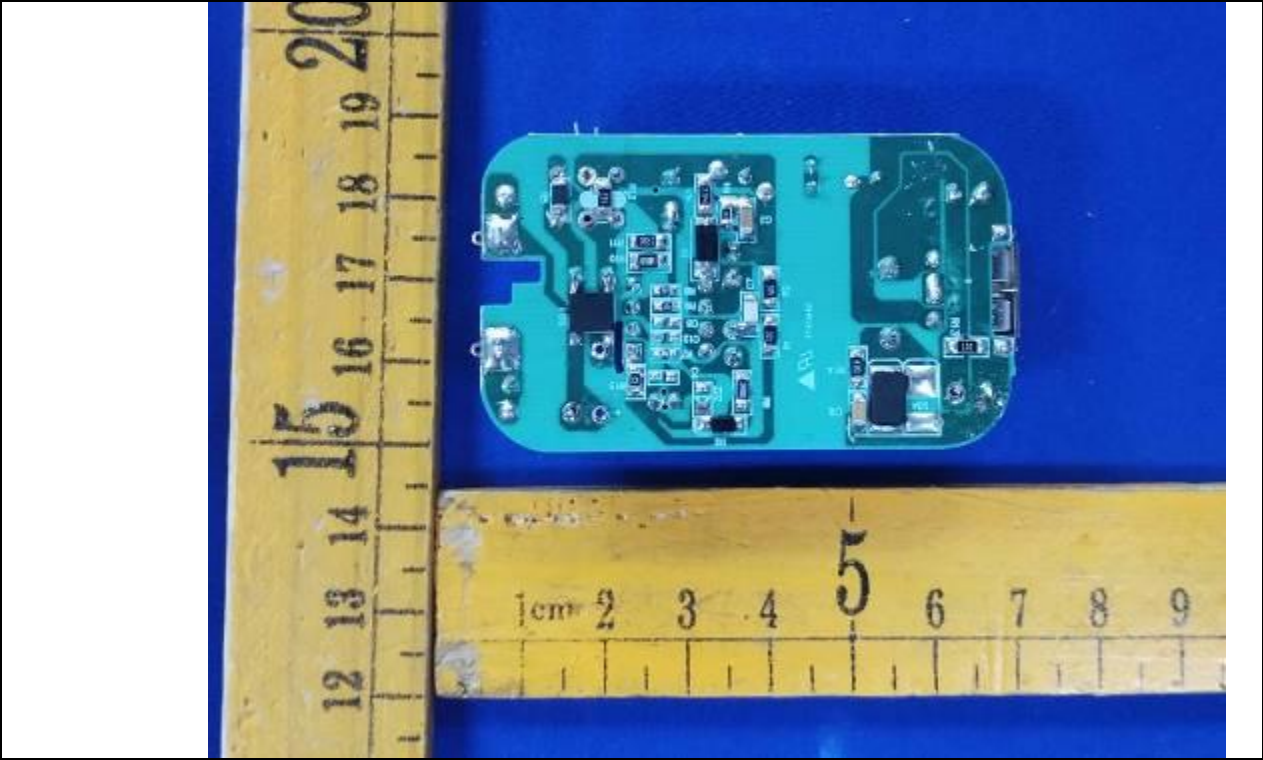

Details of: PCB component view-22 (models: CZH015xxxxyymmWHL, CZH015xxxxyymmWPL) (With L1, VR1, CY1, CY2, LF2, LED1 used, without LF1, C3A) (PCB type B)

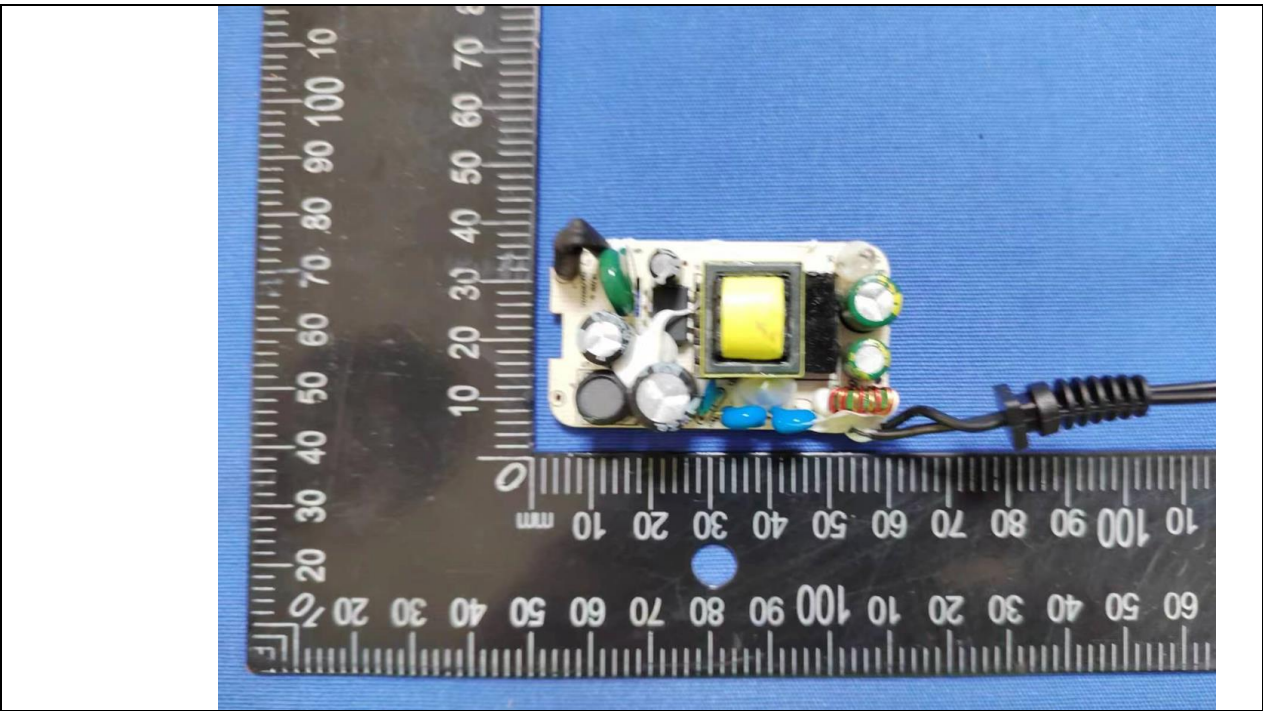

Attachment No. 5

Details of: PCB component view-23 (models: CZH015xxxxyymmWHL, CZH015xxxxyymmWPL)
(With LF1, VR1, CY1, CY2, LF2, LED1 used, without L1, C3A) (PCB type B)

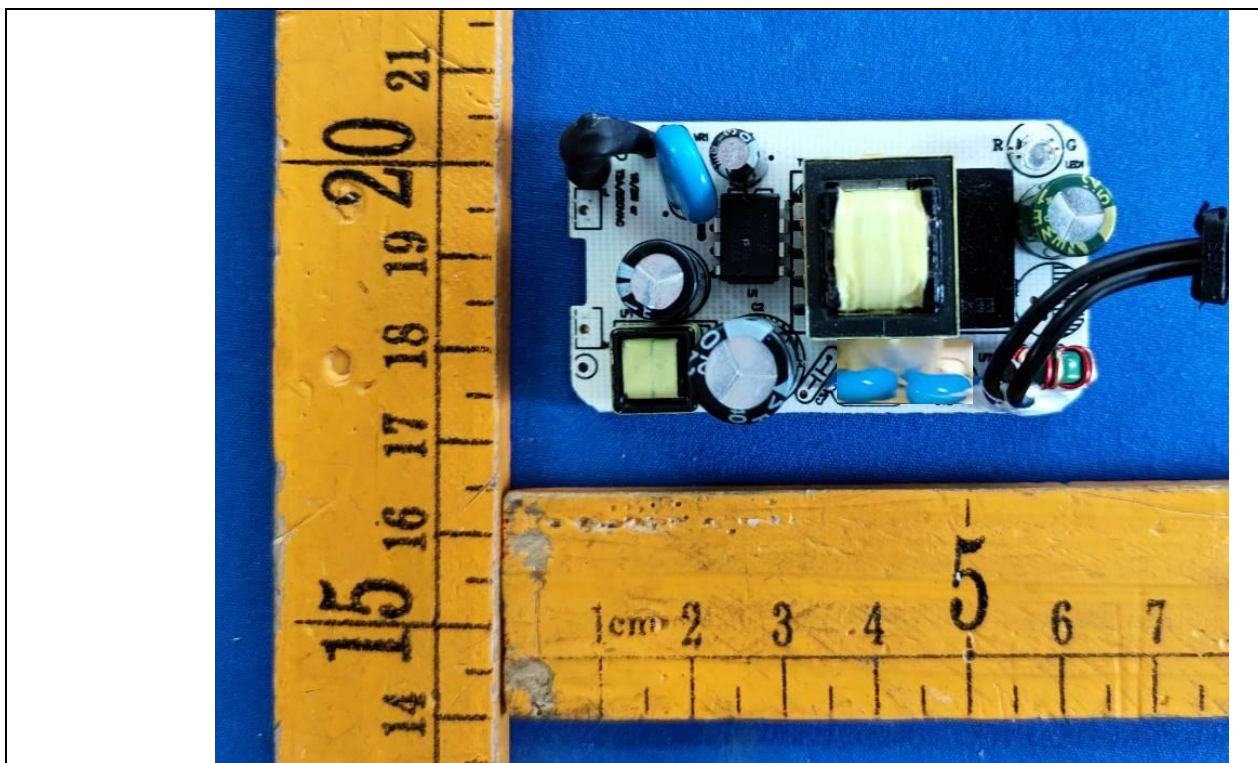

Details of: PCB component view-24 (models: CZH015xxxxyymmWHL, CZH015xxxxyymmWPL)
(With L1, CY1, CY2, LF2, LED1 used, without LF1, C3A, VR1) (PCB type B)

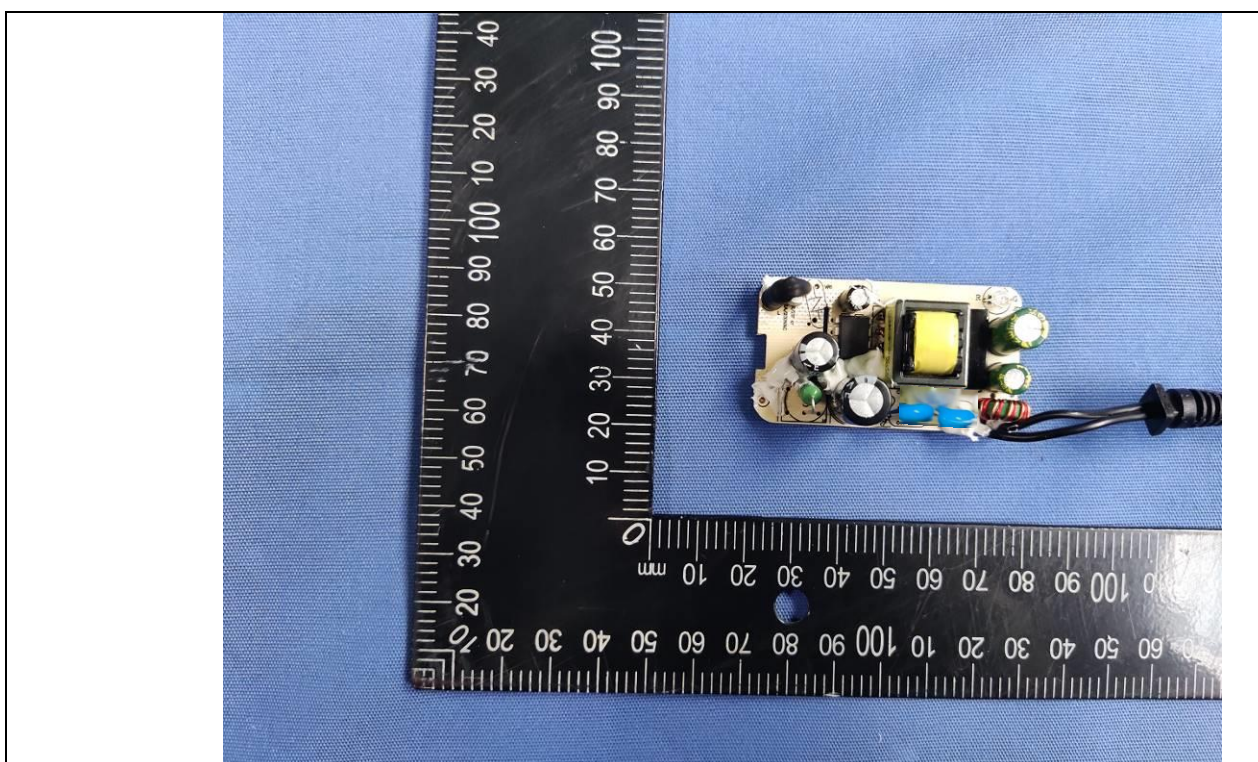

Details of: PCB trace view-25 (models: CZH015xxxxyyymmWHL, CZH015xxxxyyymmWPL) (PCB type B)

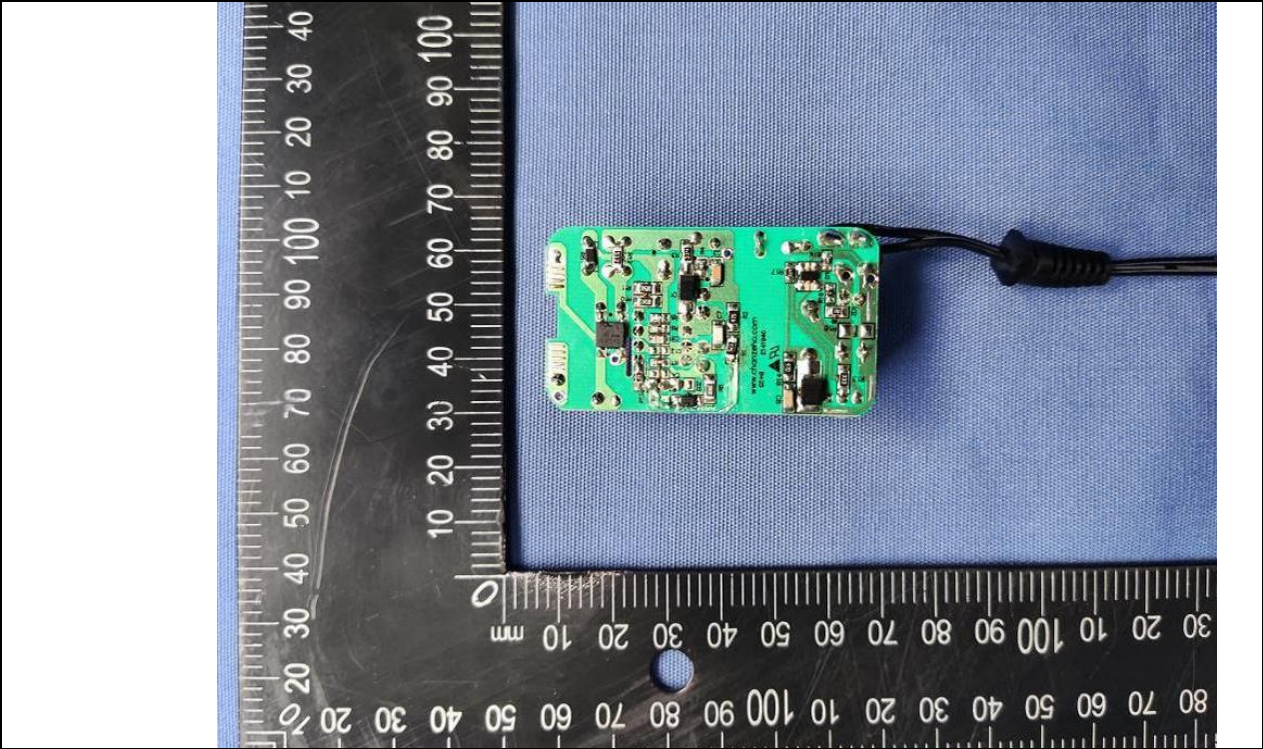

Details of: PCB component view-26 (models: CZH015xxxxyyymmWH, CZH015xxxxyyymmWP) (With L1, VR1, C10, LF2, L2, D3 used, without LF1, C3A) (PCB type A)

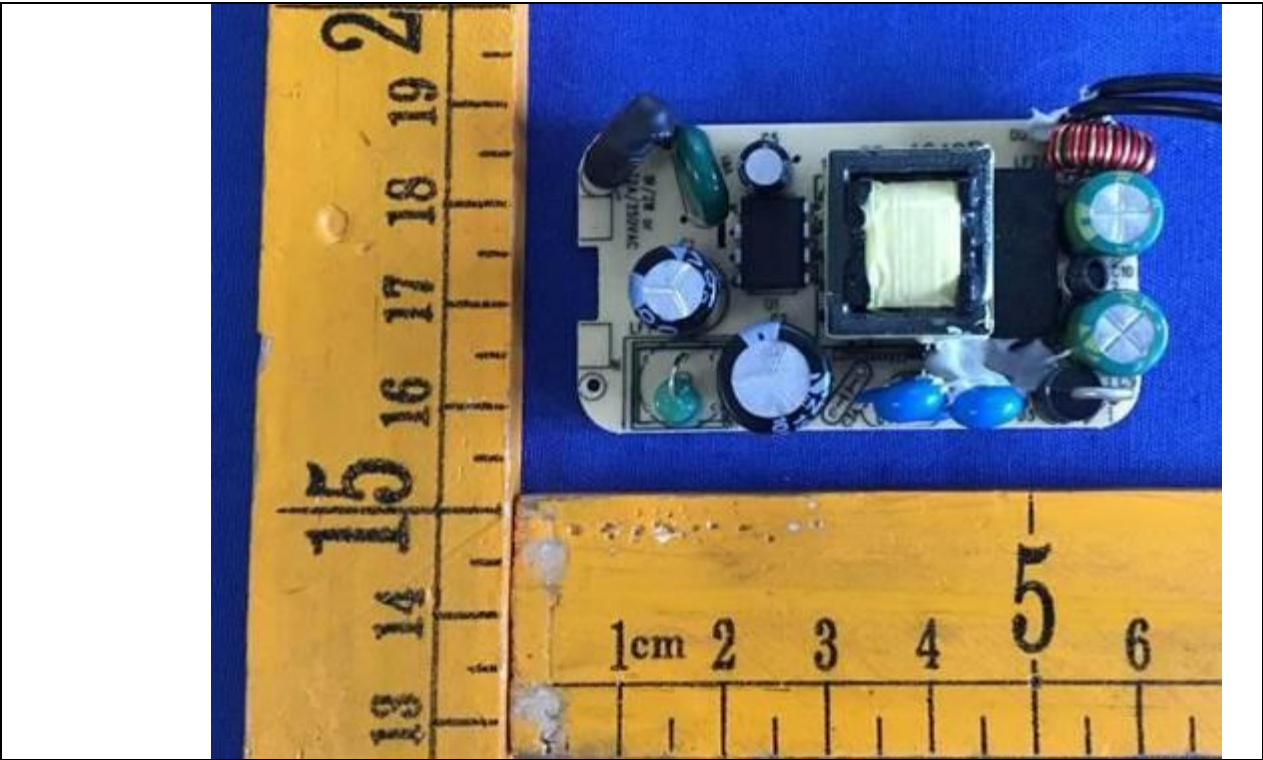

Attachment No. 5

Details of: PCB component view-27 (models: CZH015xxxxyymmWH, CZH015xxxxyymmWP) (With L1 used, without LF1, VR1, C3A, C10, LF2, L2, D3) (PCB type A)

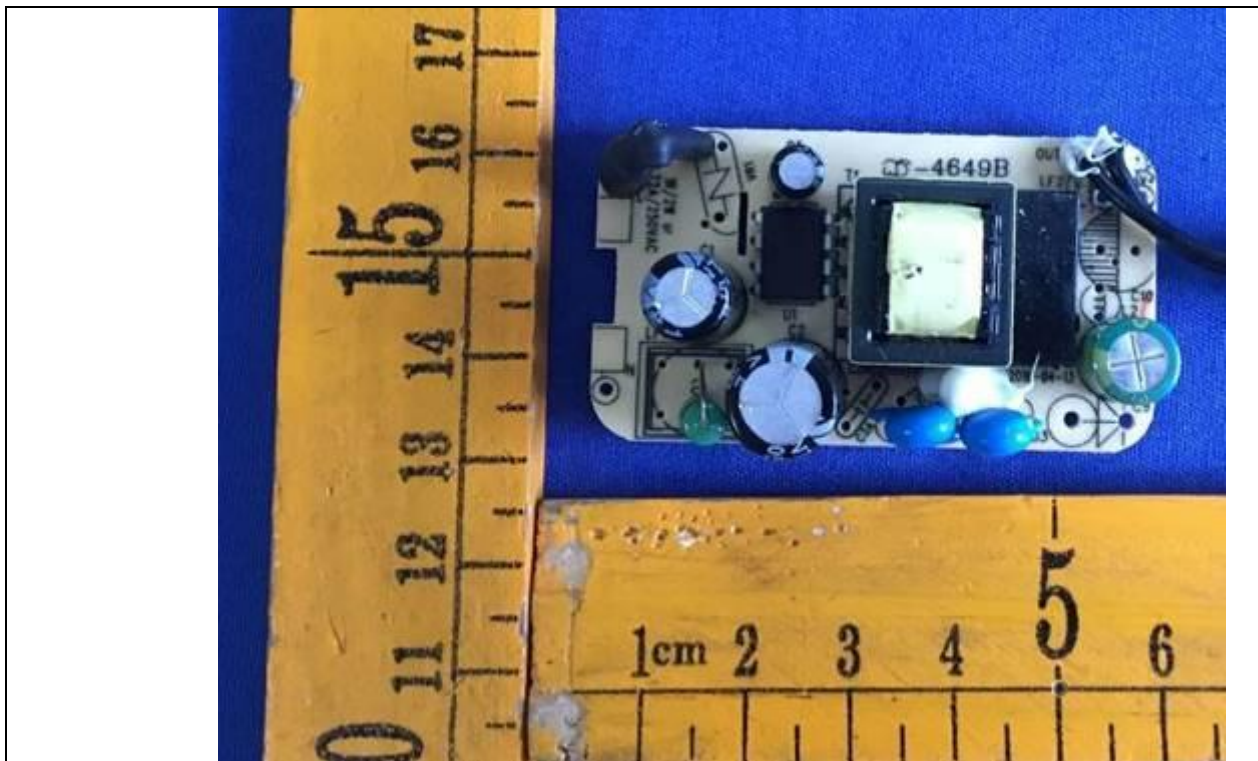

Details of: PCB component view-28 (models: CZH015xxxxyymmWH, CZH015xxxxyymmWP) (With L1 used, without LF1, VR1, C3A, C10, LF2, L2, D3) (PCB type A)



Attachment No. 5

Details of: PCB component view-29 (models: CZH015xxxxyymmWH, CZH015xxxxyymmWP) (With LF1 used, without L1, VR1, C3A, C10, LF2, L2, D3) (PCB type A)

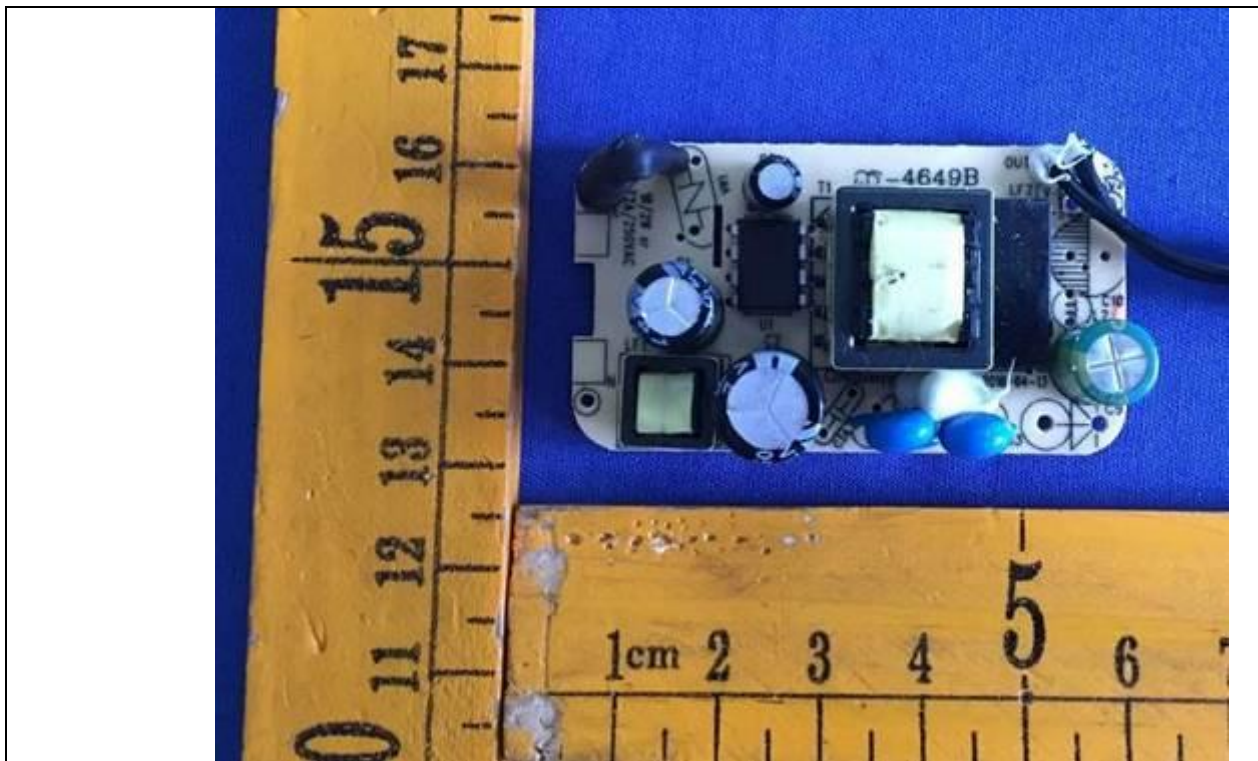

Details of: PCB component view-30 (models: CZH015xxxxyymmWH, CZH015xxxxyymmWP) (With LF1, D3 used, without L1, VR1, C3A, C10, LF2, L2) (PCB type A)



Attachment No. 5

Details of: PCB component view-31 (models: CZH015xxxxyymmWH, CZH015xxxxyymmWP) (With LF1, D3, C10 used, without L1, VR1, C3A, LF2, L2) (PCB type A)

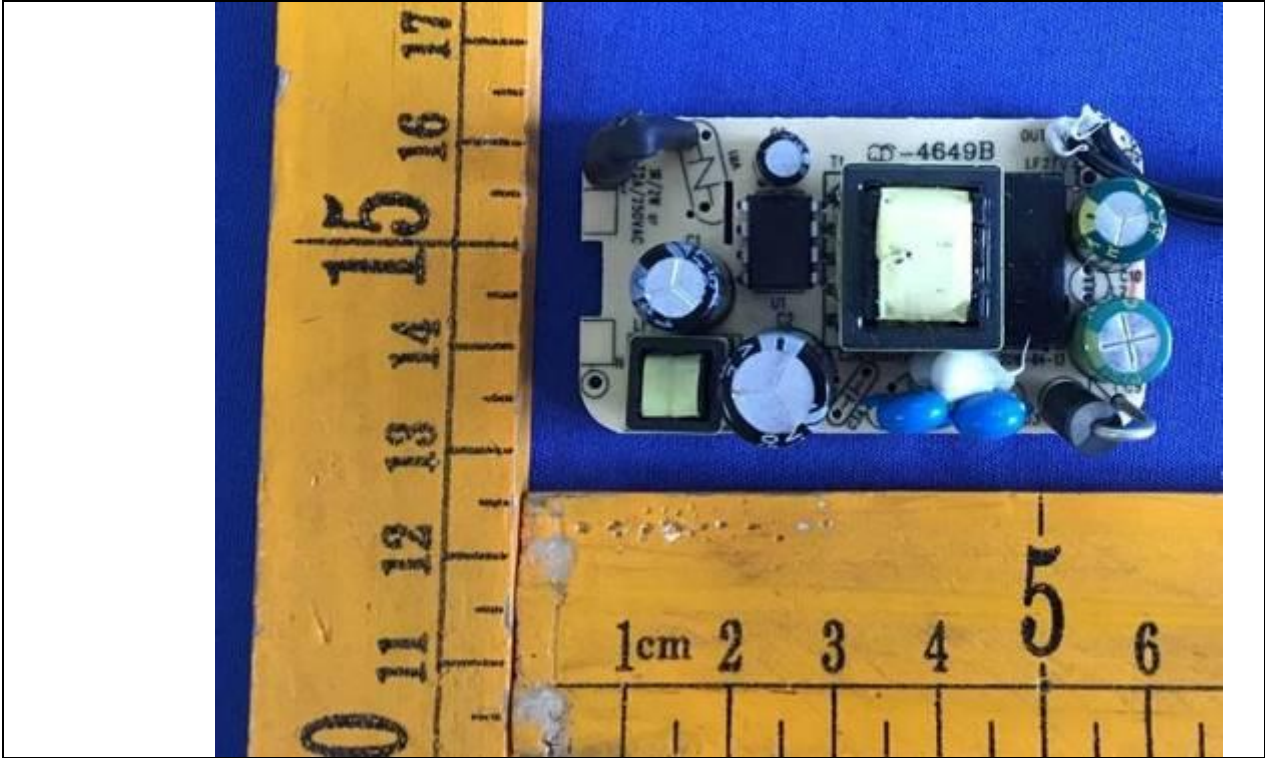

Details of: PCB component view-32 (models: CZH015xxxxyymmWH, CZH015xxxxyymmWP) (With L1, C3A, C10 used, without LF1, VR1, LF2, L2, D3) (PCB type A)



Details of: PCB component view-33 (models: CZH015xxxxyymmWH, CZH015xxxxyymmWP) (With LF1, CY3 used, without VR1, LF2, L2, D3) (PCB type A)

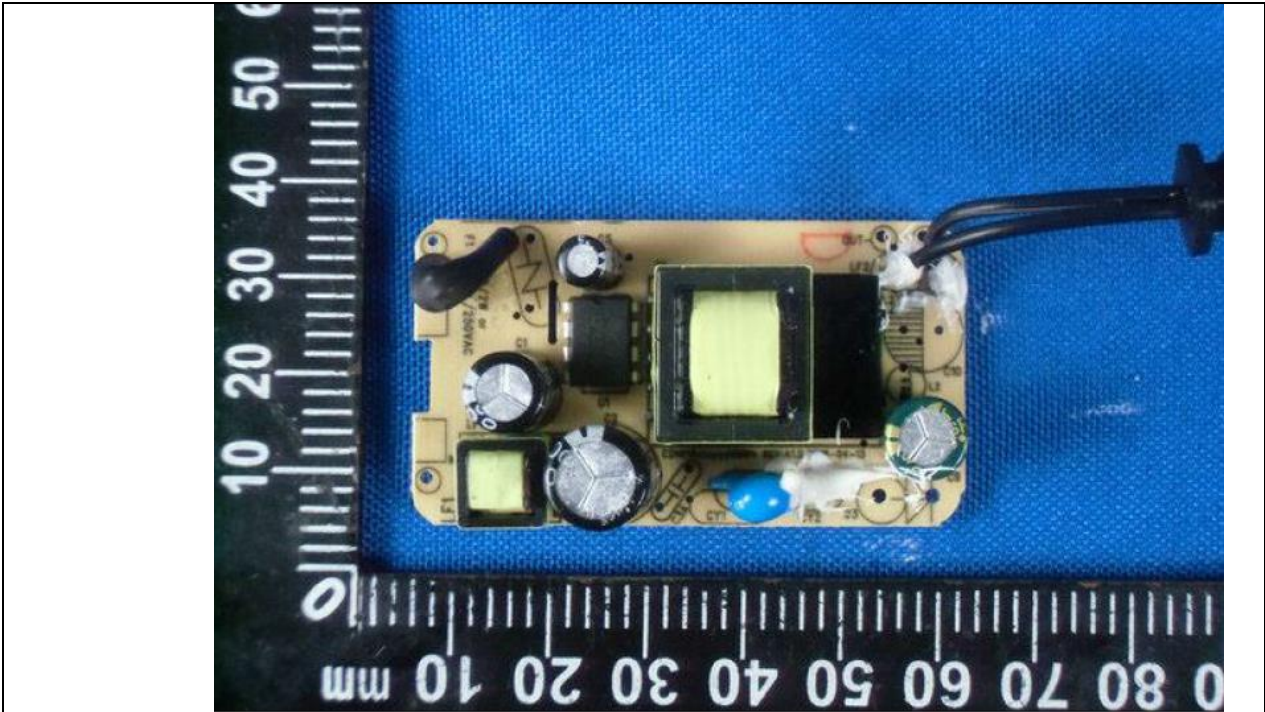

Details of: PCB trace view-34 (models: CZH015xxxxyymmWH, CZH015xxxxyymmWP) (With R5, R12, D3A used, without C4, ZD2, C3, ZD1, C11) (PCB type A)

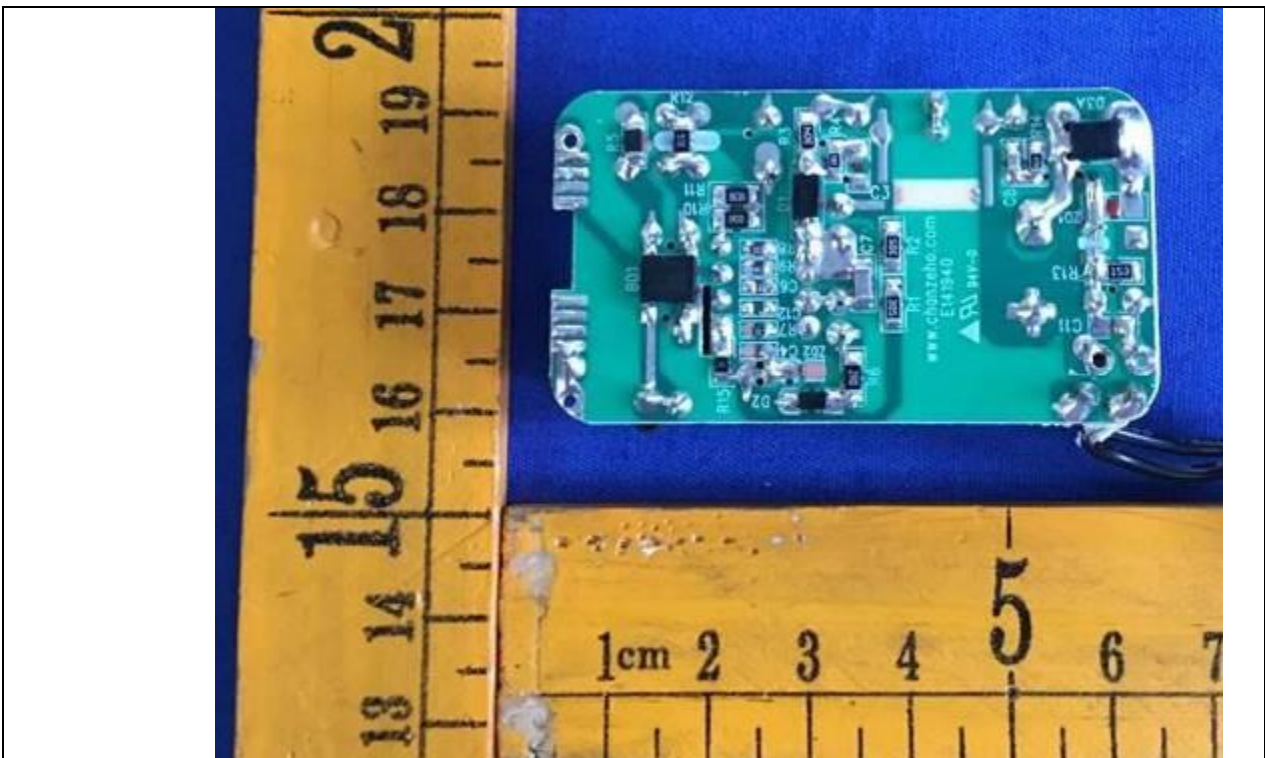

Attachment No. 5

Details of: PCB trace view-35 (models: CZH015xxxxyyymmWH, CZH015xxxxyyymmWP) (With R5, R12, C4, ZD2, C3, ZD1, C11, D3A used) (PCB type A)

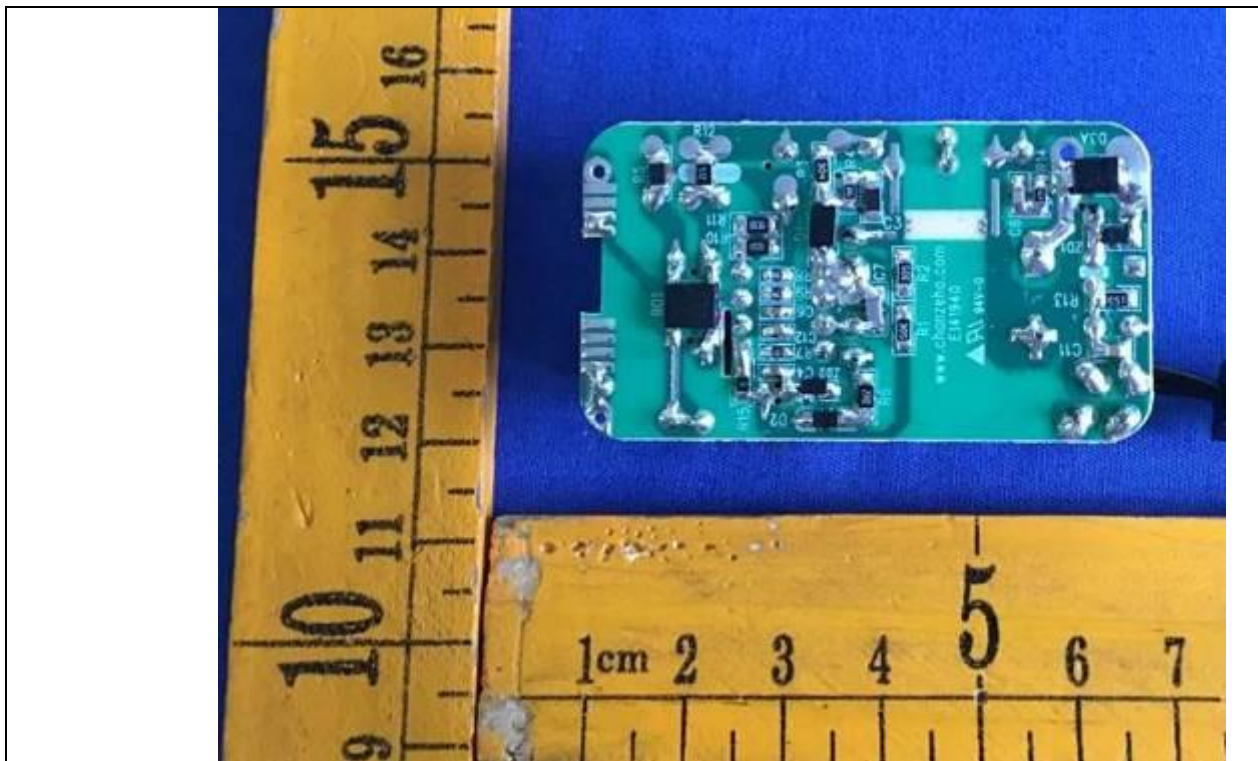

Details of: PCB trace view-36 (models: CZH015xxxxyyymmWH, CZH015xxxxyyymmWP) (Without R5, R12, C4, ZD2, C3, ZD1, C11, D3A) (PCB type A)



Attachment No. 5

Details of: PCB trace view-37 (models: CZH015xxxxyyymmWH, CZH015xxxxyyymmWP) (With R12, D3A used, without R5, C4, ZD2, C3, ZD1, C11) (PCB type A)

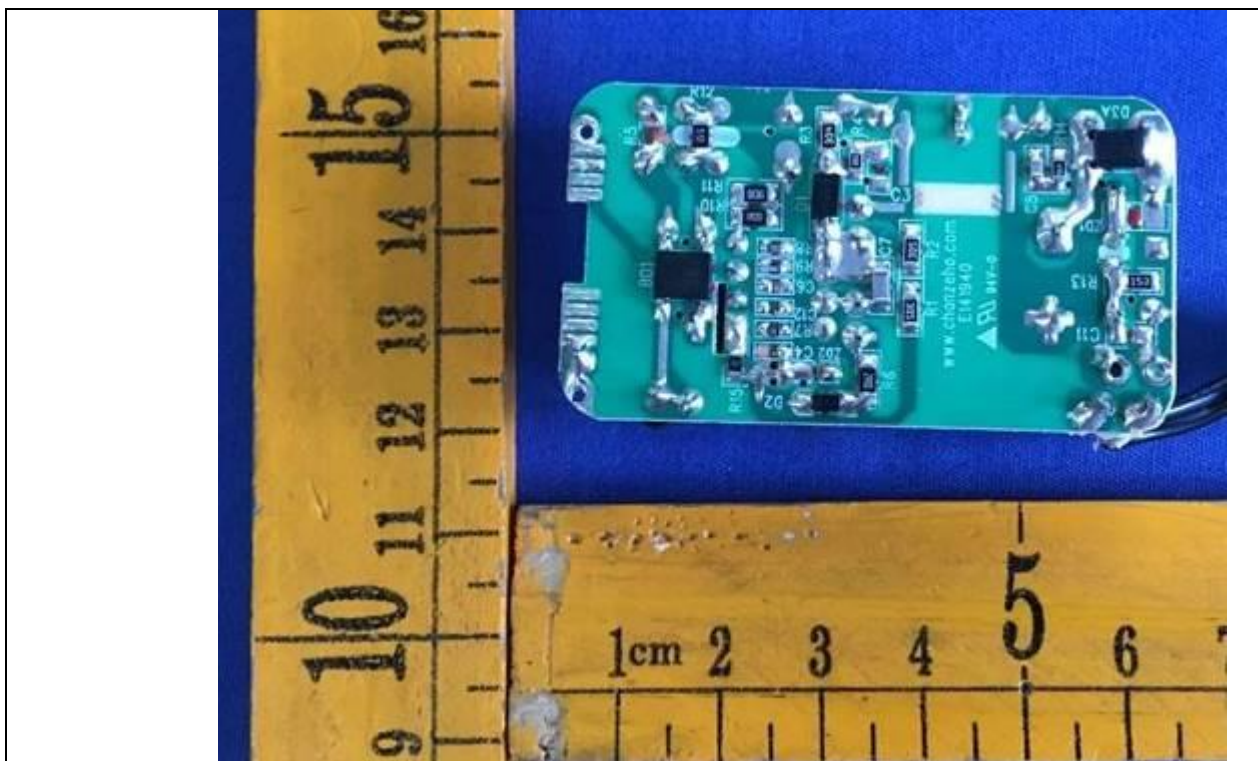

Details of: PCB trace view-38 (models: CZH015xxxxyyymmWH, CZH015xxxxyyymmWP) (PCB type A)

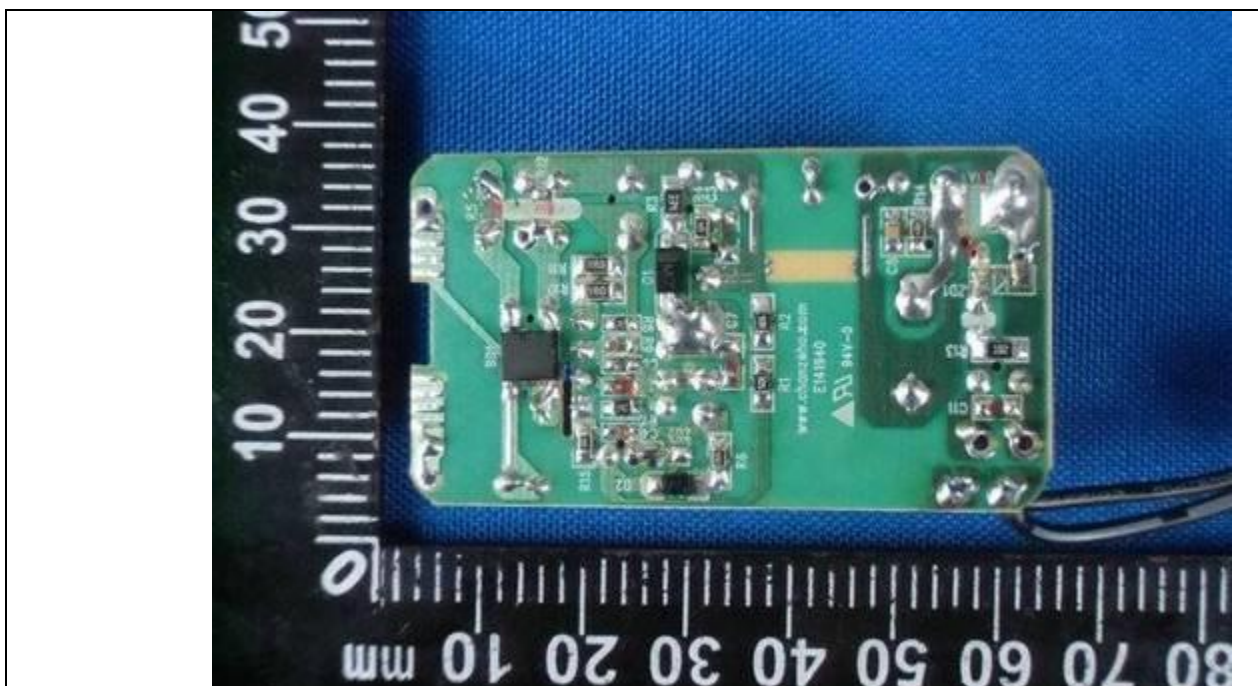

Details of: PCB trace view-39 (models: CZH015xxxxyyymmWQ, CZH015xxxxyyTRWQ) (PCB type A)

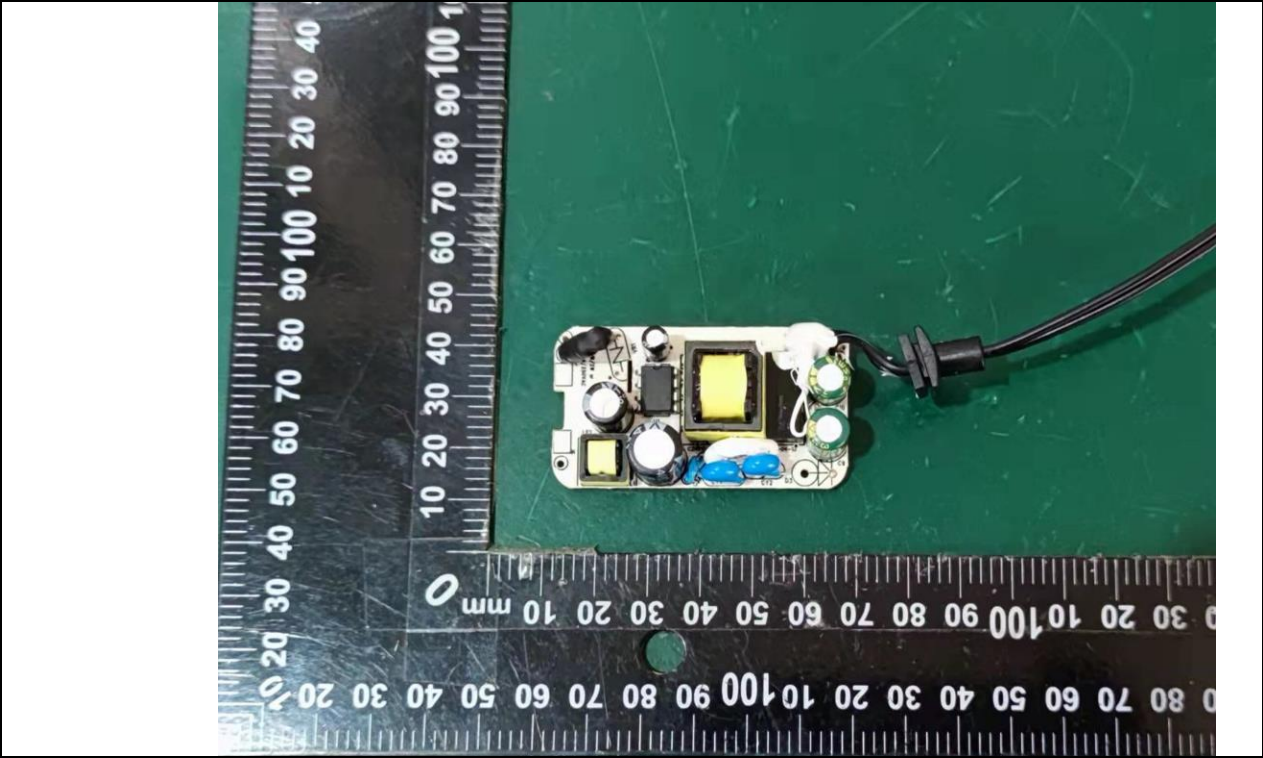

Details of: PCB trace view-40 (models: CZH015xxxxyyymmWQ, CZH015xxxxyyTRWQ) (PCB type A)

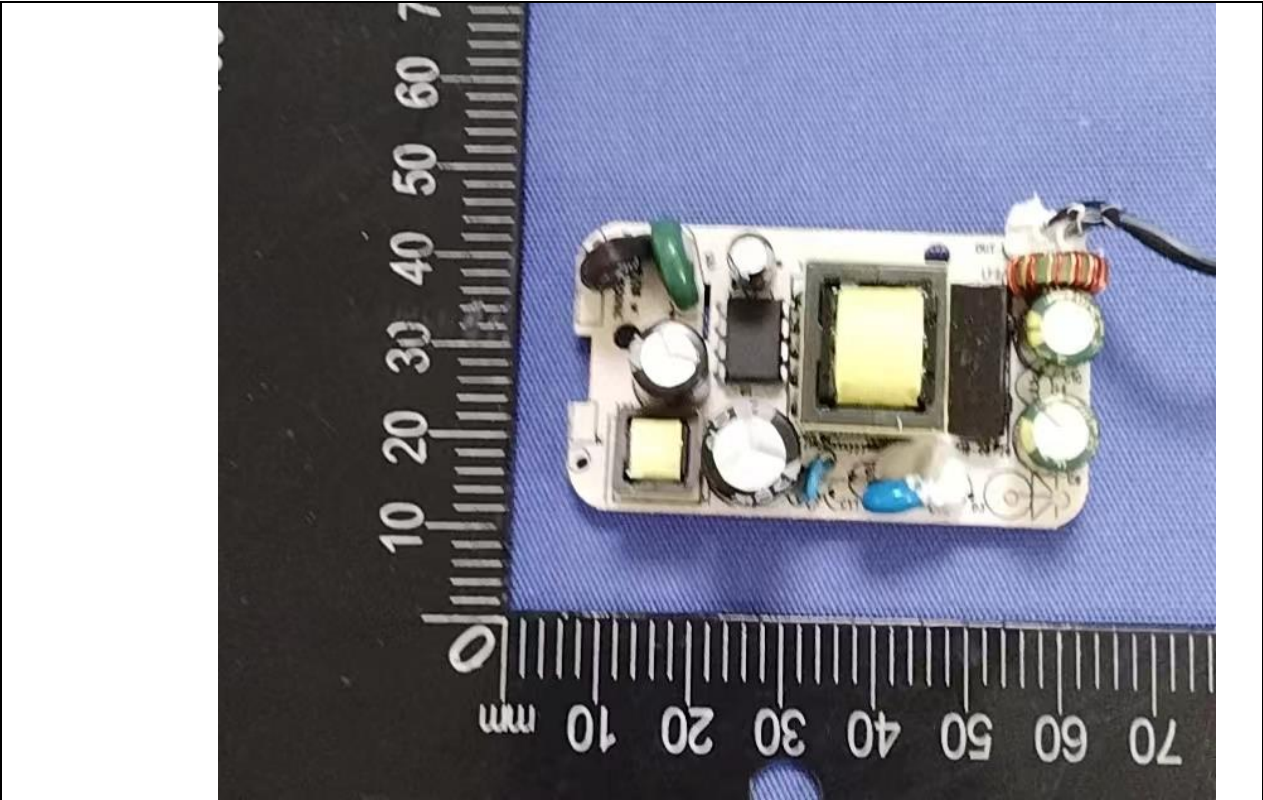

Details of: PCB trace view-41 (models: CZH015xxxxyyymmWQ, CZH015xxxxyyTRWQ) (PCB type A)

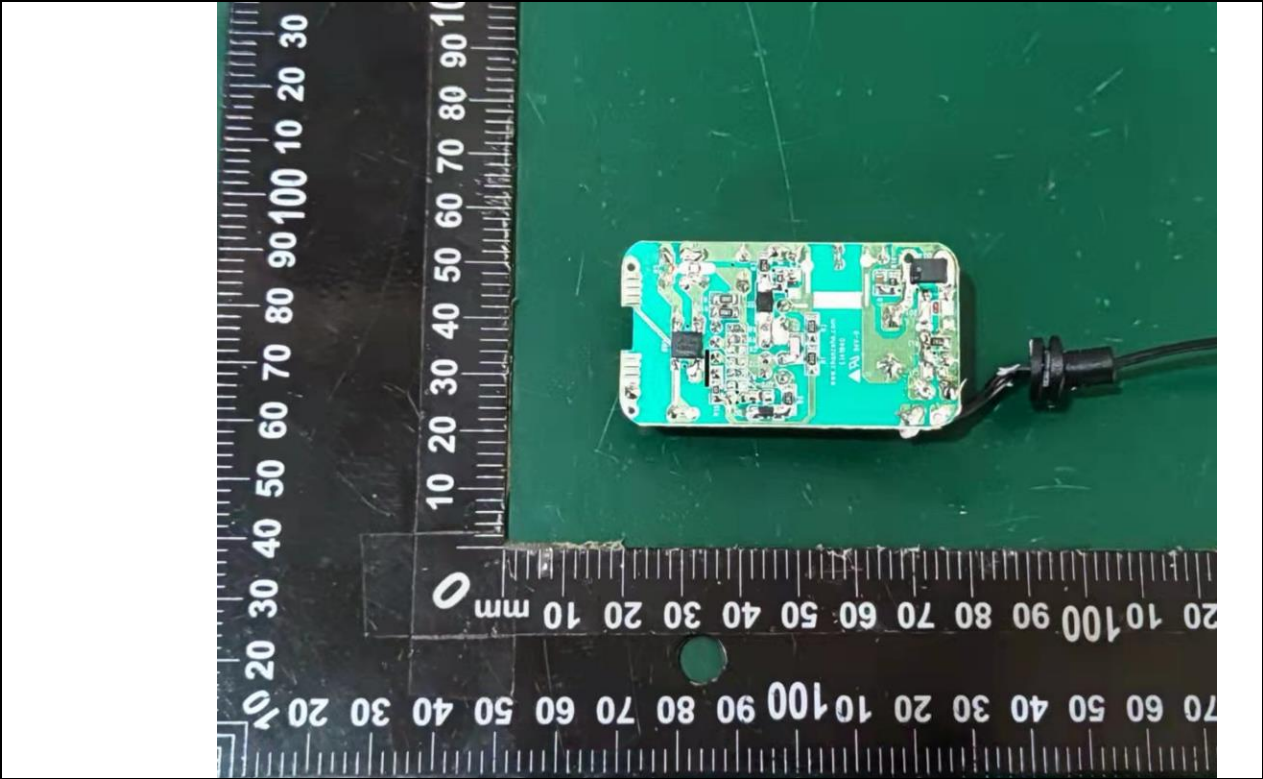

Details of: PCB trace view-42 (models: CZH015xxxxyyEUWAa) (PCB type E)

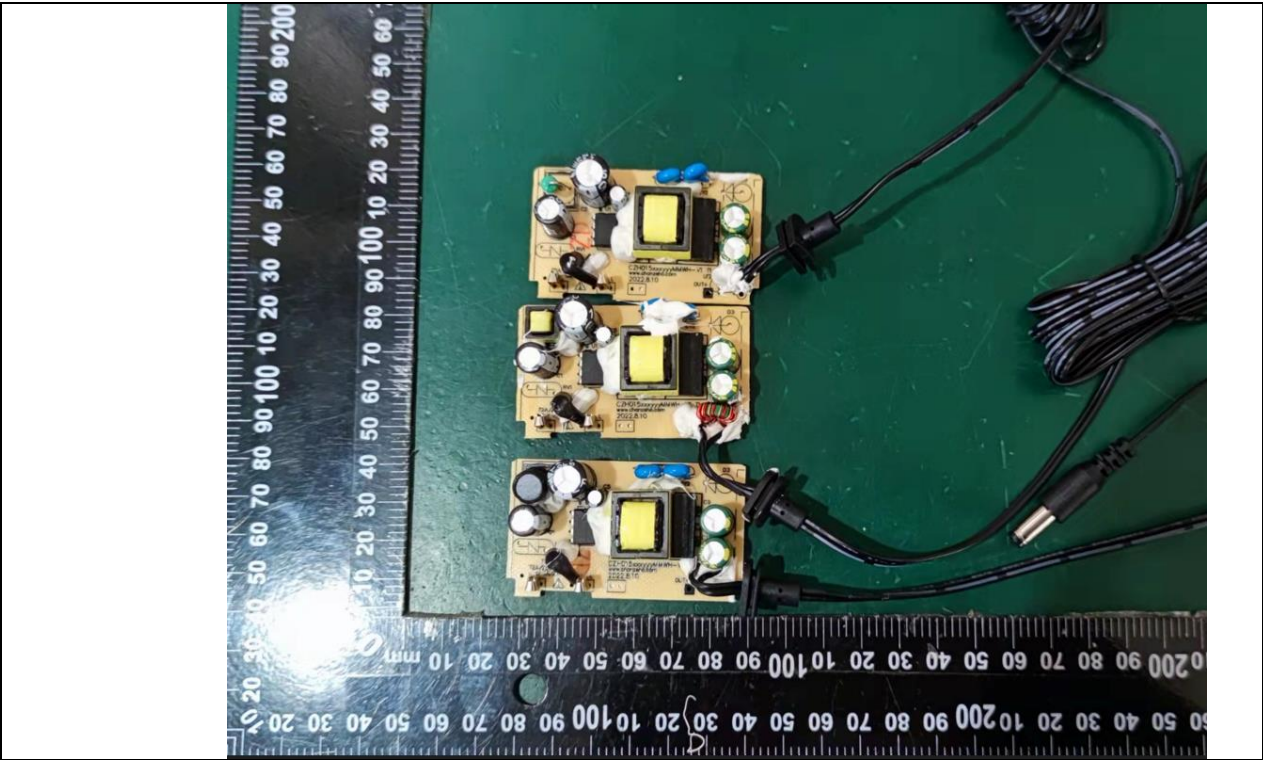

Details of: PCB trace view-43 (models: CZH015xxxxxyyEUWAa) (PCB type E)

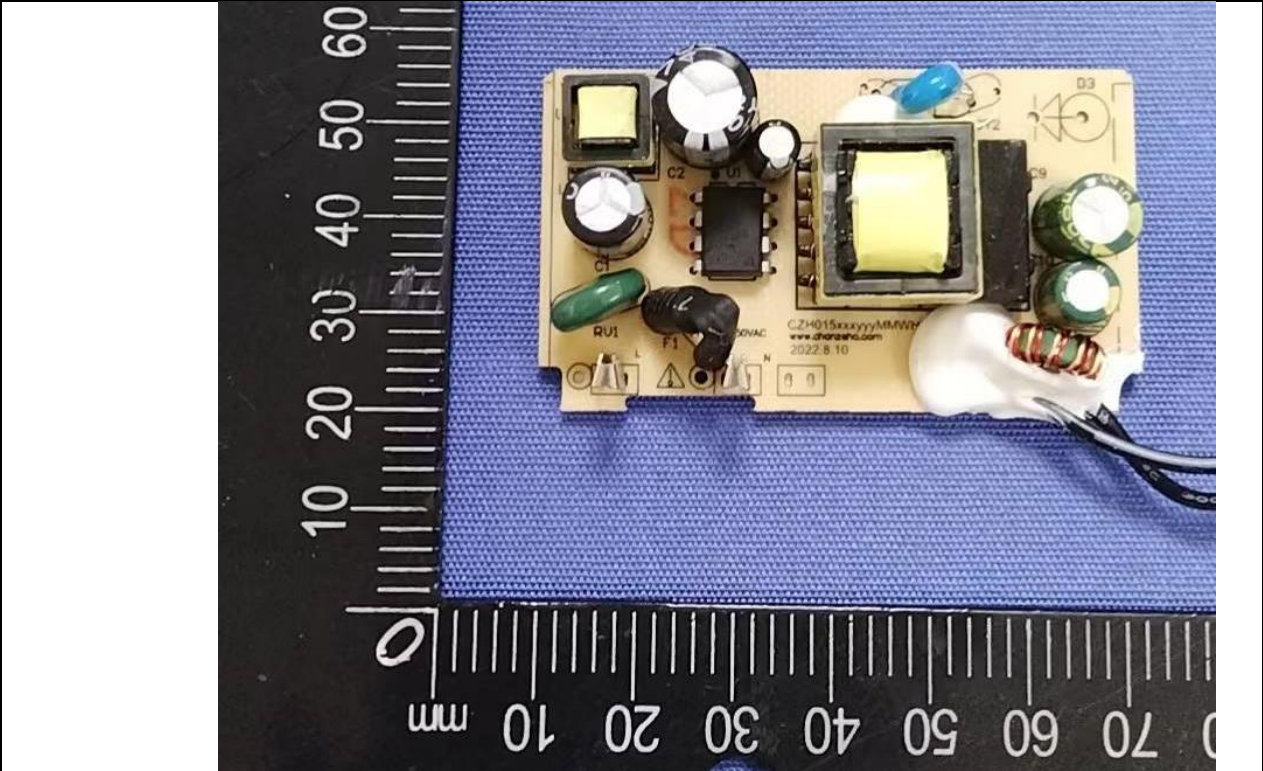

Details of: PCB trace view-44 (models: CZH015xxxxxyyEUWAa) (PCB type E)



Details of: PCB trace view-45 (models: CZH015050yyymmUGa, without input wire) (PCB type F)

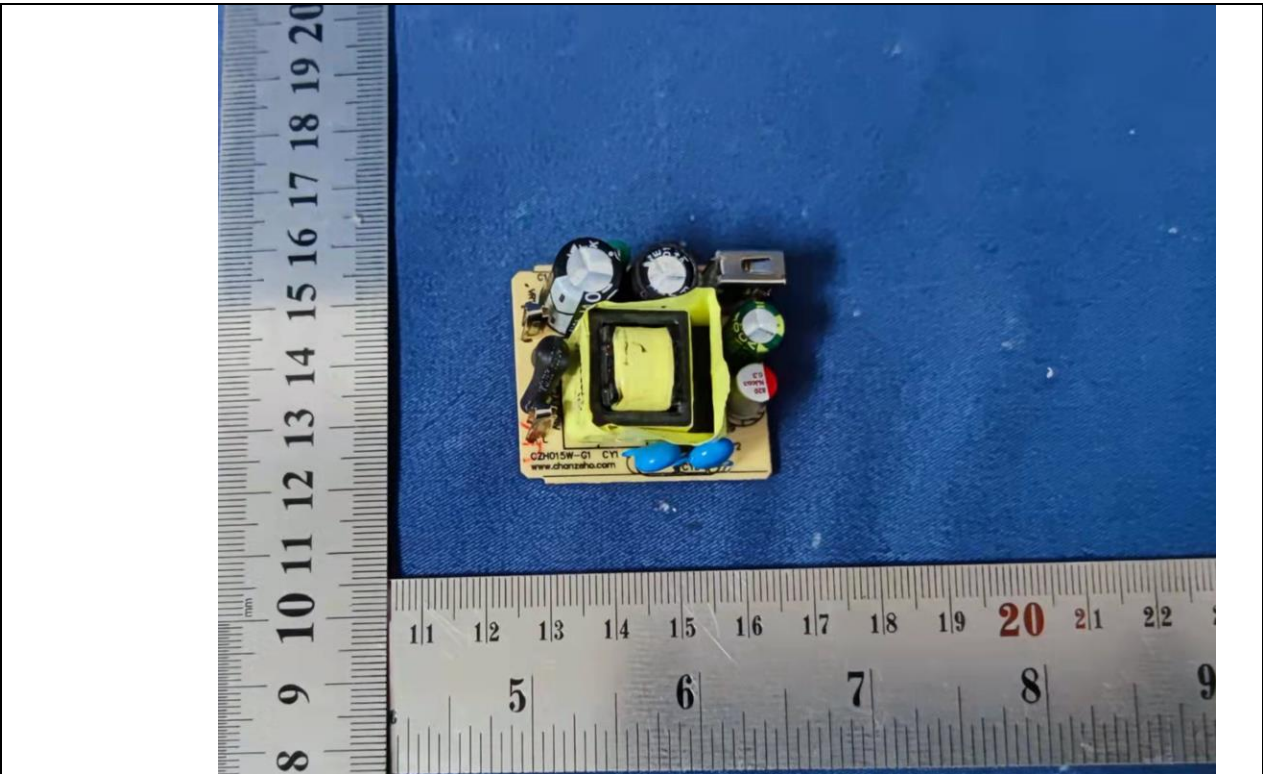

Details of: PCB trace view-46 (models: CZH015050yyymmUGa, without input wire) (PCB type F)

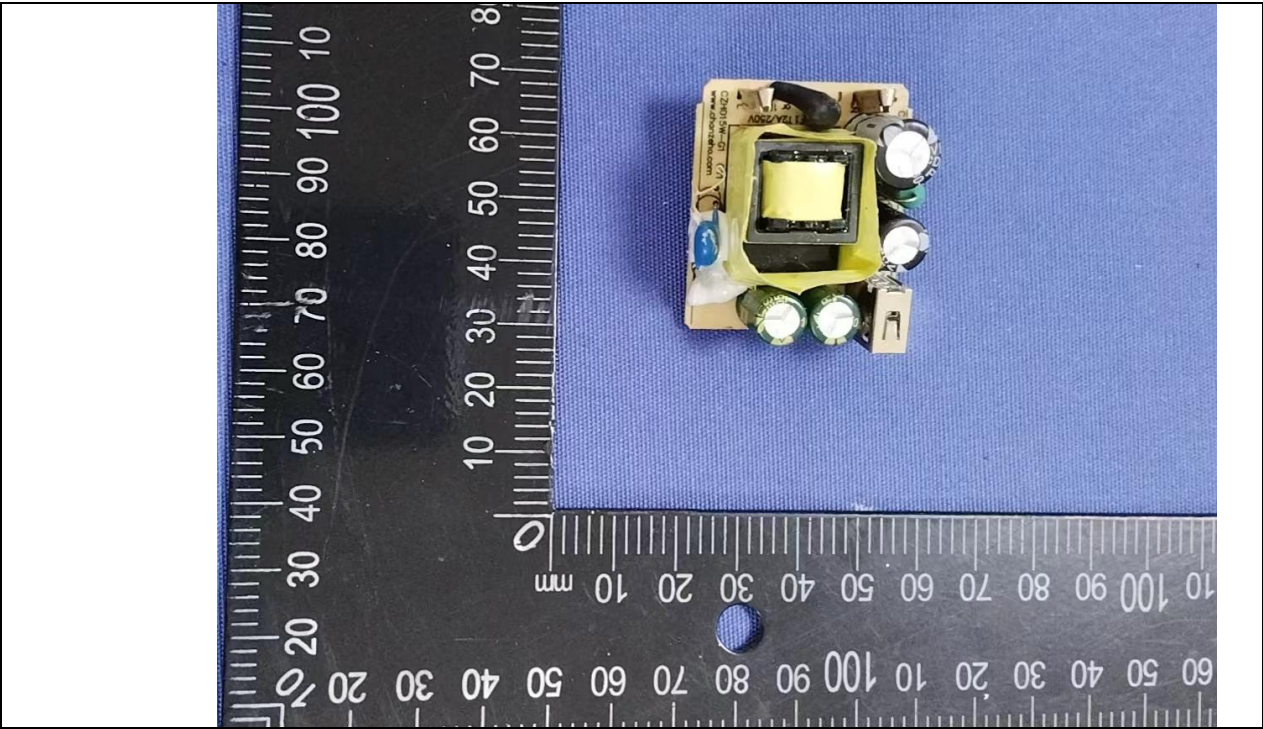

Details of: PCB trace view-47 (models: CZH015050yyymmUGa, without input wire) (PCB type F)

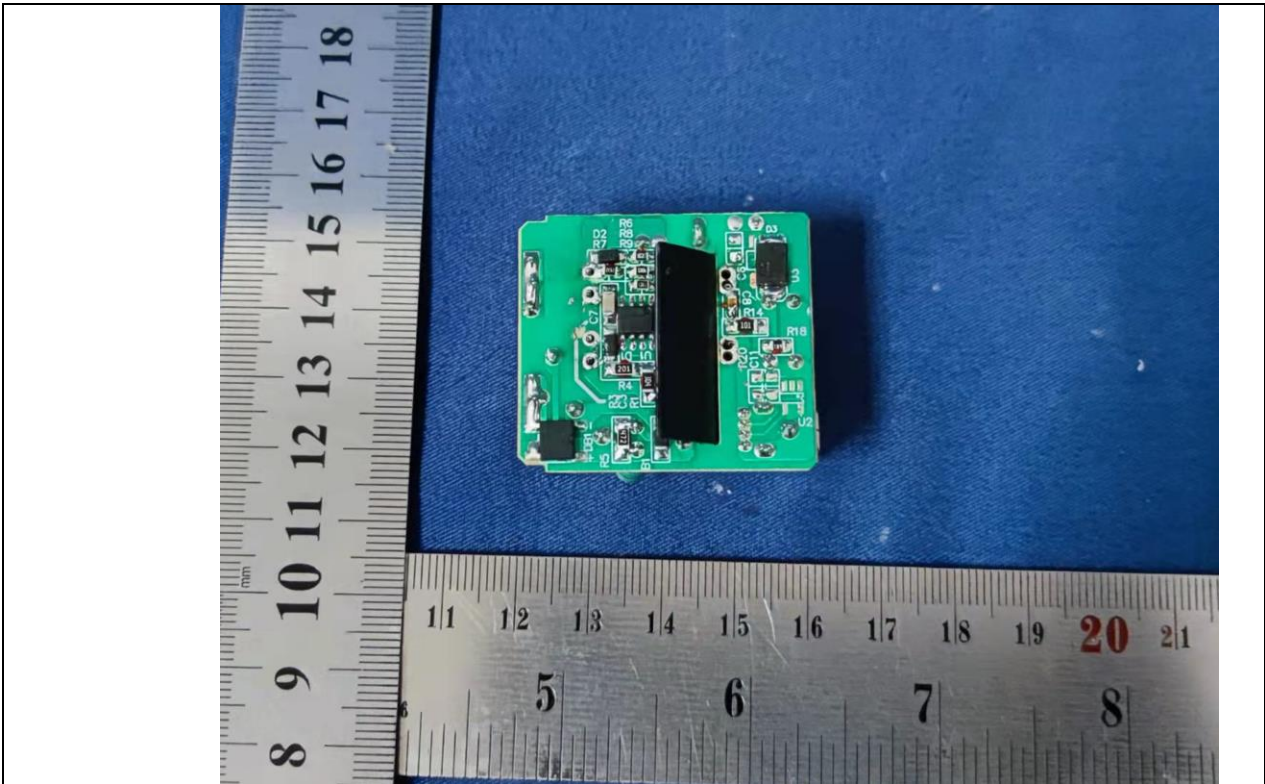

Details of: PCB trace view-48 (models: CZH015050yyymmUGa, without input wire) (PCB type F)

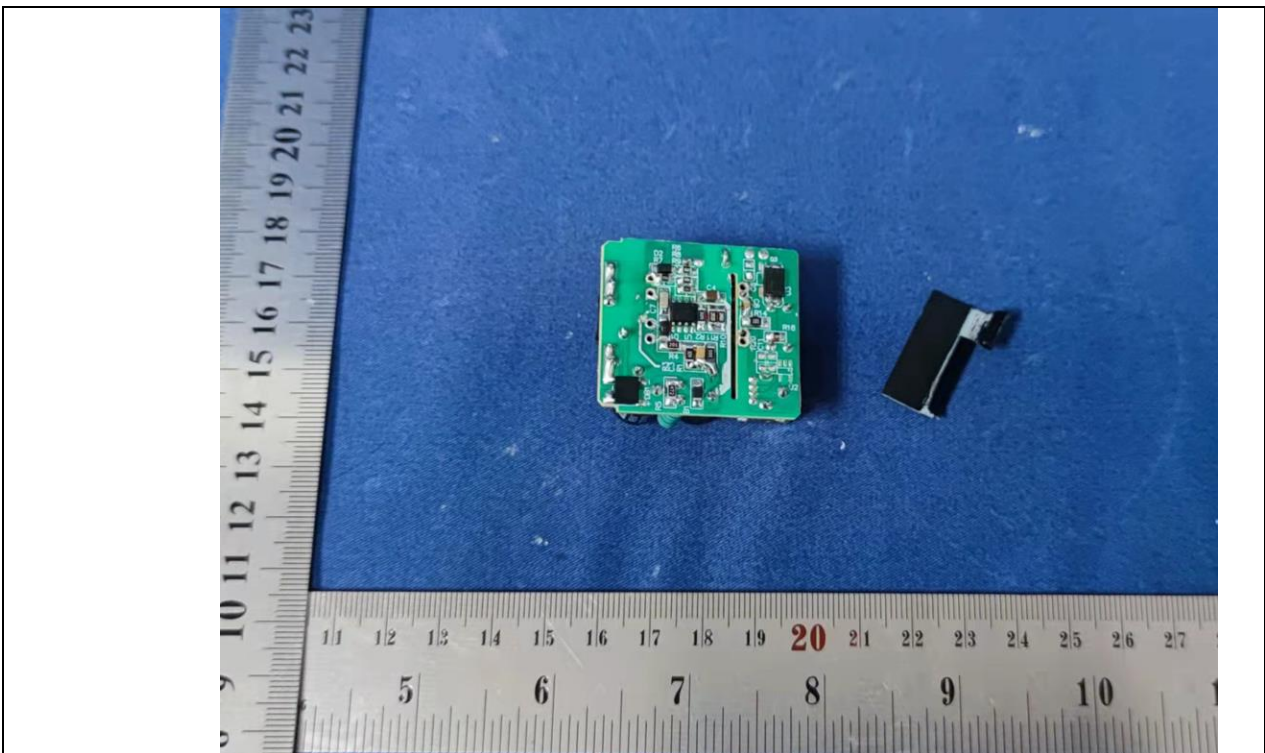

Details of: PCB trace view-49 (models: CZH015050yyymmUGa, with input wire) (PCB type F)

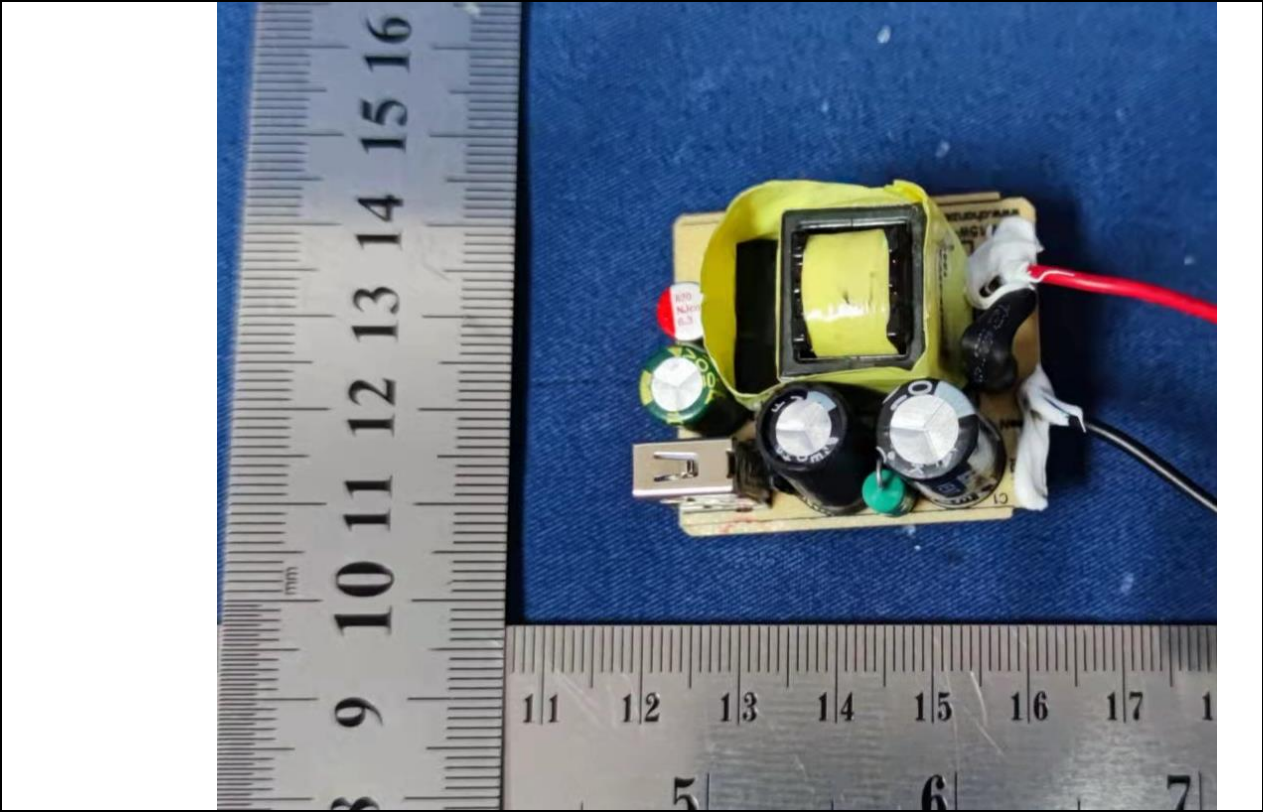

Details of: PCB trace view-50 (models: CZH015050yyymmUGa, with input wire) (PCB type F)

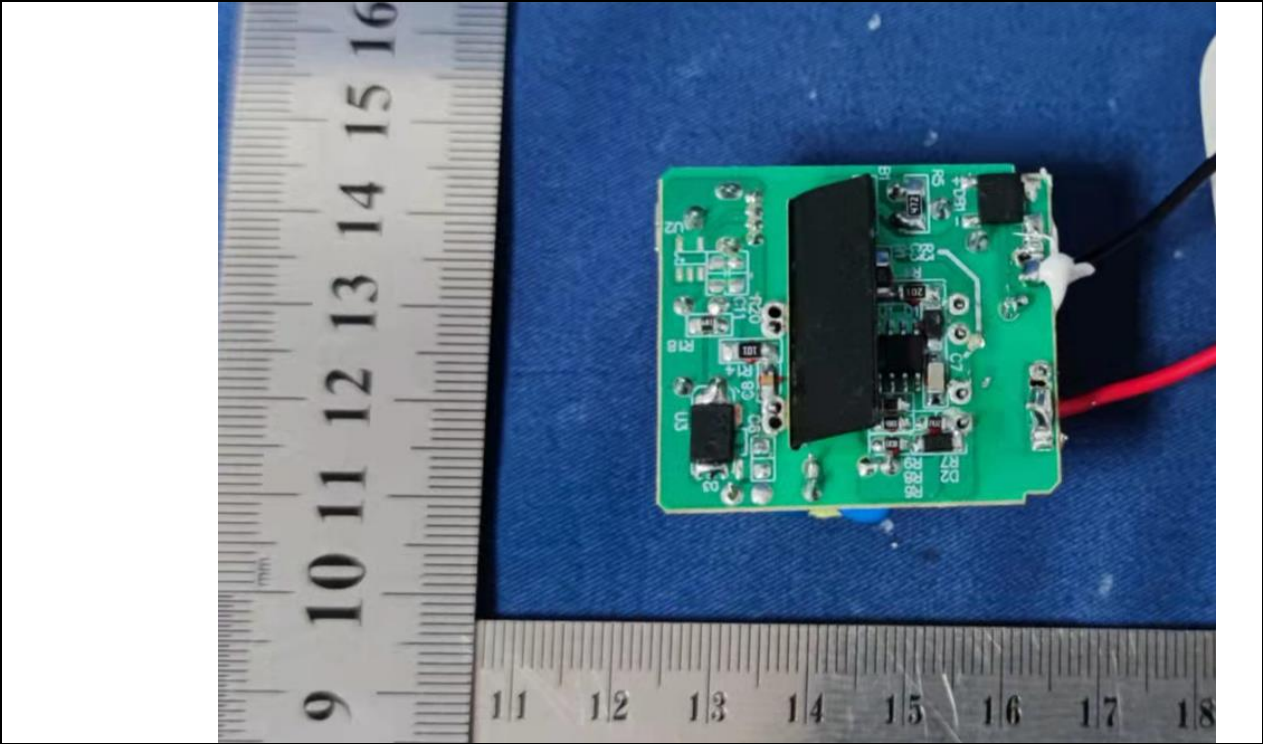

Details of: Transformer T1 view-1 (For all models except CZH015050yyymmUGa)

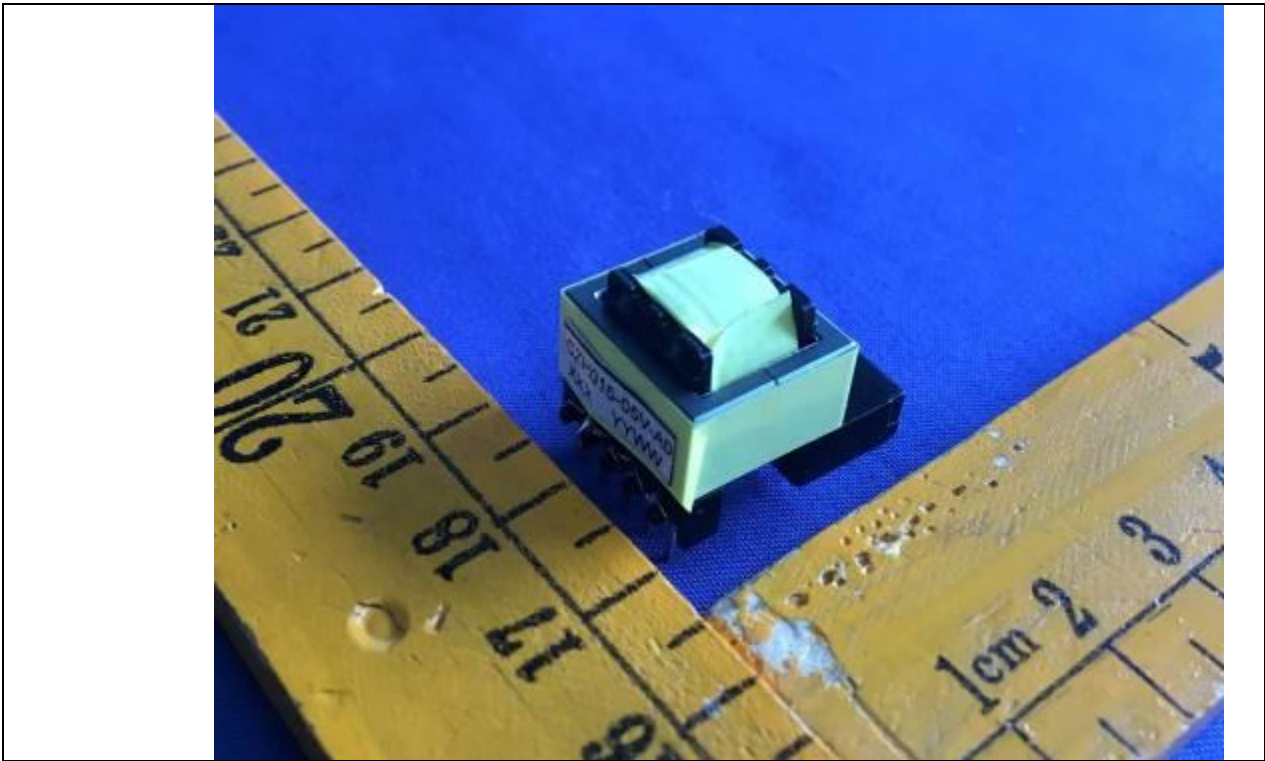

Details of: Transformer T1 view-2 (For all models except CZH015050yyymmUGa)

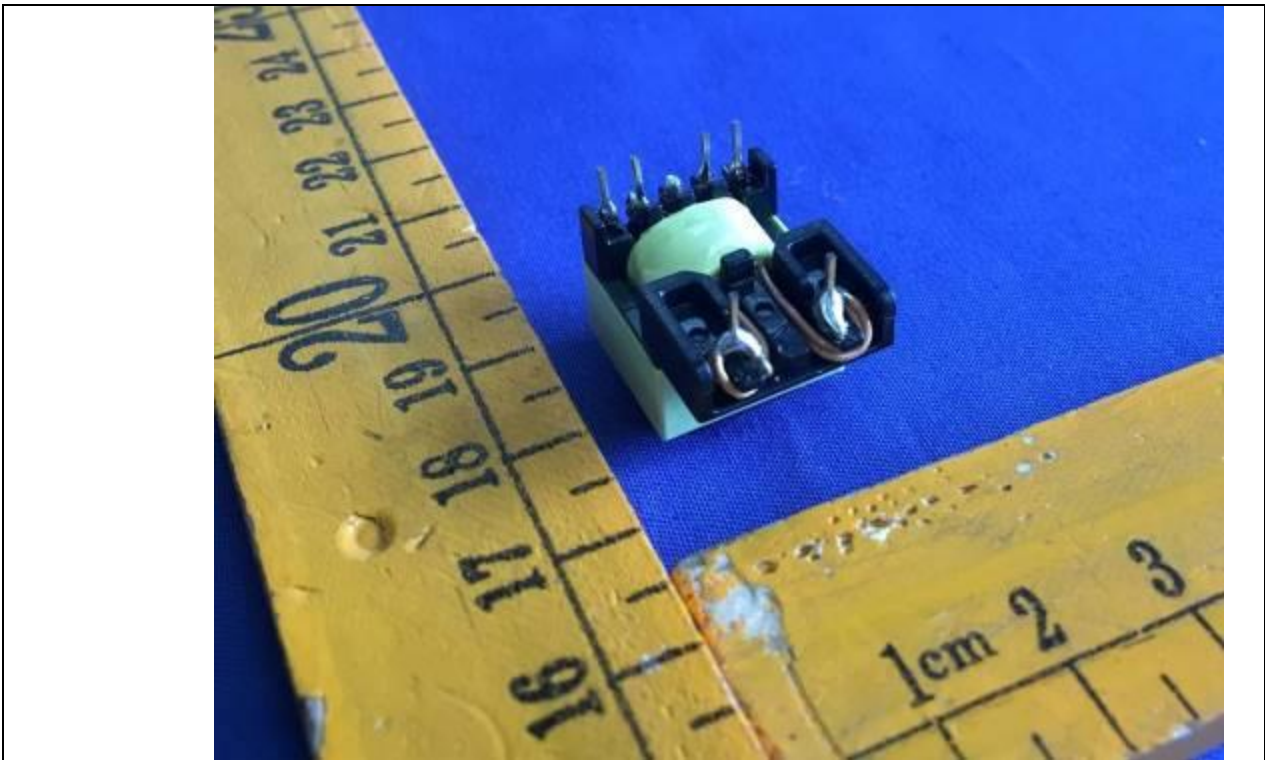

Details of: Transformer T1 view-3 (For models CZH015050yyymmUGa)

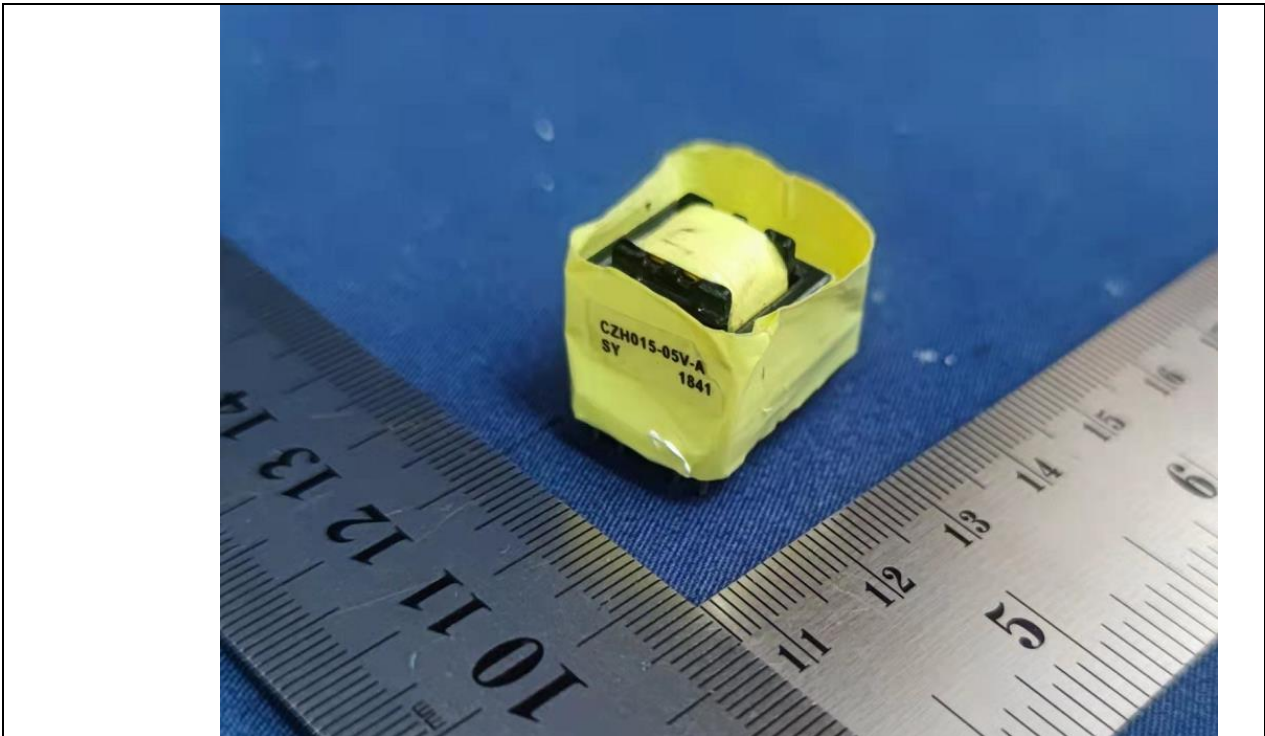

Details of: Transformer T1 view-4 (For models CZH015050yyymmUGa)

