



中国认可
国际互认
检测
TESTING
CNAS L5772

CE EMC TEST REPORT

for

Product: ROBOT VACUUM CLEANER

Model: KRV305A,KRV305B

Report No.: PTC22111004601E-EM01

Issued for

Issued by

Precise Testing & Certification (Guangdong) Co., Ltd.

**Building 1, No. 6, Tongxin Road, Dongcheng Street, Dongguan, Guangdong,
China.**

TEL: +86-769-3880 8222

FAX: + 86-769-3882 6111

Note: This report shall not be reproduced except in full, without the written approval of Precise Testing & Certification (Guangdong) Co., Ltd. This document may be altered or revised by Precise Testing & Certification (Guangdong) Co., Ltd. personnel only, and shall be noted in the revision section of the document. The test results presented in this report only relate to the tested sample.





TABLE OF CONTENTS

1. TEST CERTIFICATION	3
2. TEST SUMMARY	4
3. TEST SITE	5
3.1. TEST FACILITY	5
3.2. Measurement Uncertainty	5
3.3. LIST OF TEST AND MEASUREMENT INSTRUMENTS	6
4. EUT DESCRIPTION	9
5. TEST METHODOLOGY	10
5.1. TEST MODE	10
5.2. EUT SYSTEM OPERATION	10
6. SETUP OF EQUIPMENT UNDER TEST	11
6.1. DESCRIPTION OF SUPPORT UNITS	11
6.2. CONFIGURATION OF SYSTEM UNDER TEST	11
7. EMISSION TEST	12
7.1. CONDUCTED EMISSION MEASUREMENT	12
7.2. CLICK MEASUREMENT	18
7.3. DISTURBANCE POWER MEASUREMENT	20
7.4. RADIATED EMISSION MEASUREMENT	22
7.5. HARMONICS CURRENT MEASUREMENT	32
7.6. VOLTAGE FLUCTUATION AND FLICKS MEASUREMENT	36
8. IMMUNITY TEST	39
8.1. GENERAL DESCRIPTION	39
8.2. GENERAL PERFORMANCE CRITERIA DESCRIPTION	40
8.3. ELECTROSTATIC DISCHARGE (ESD)	41
8.4. RADIATED RADIO-FREQUENCY, ELECTROMAGNETIC FIELD (RS)	44
8.5. ELECTRICAL FAST TRANSIENT (EFT)	47
8.6. SURGE IMMUNITY TEST	49
8.7. CONDUCTED RADIO FREQUENCY DISTURBANCES (CS)	51
8.8. VOLTAGE DIP & VOLTAGE INTERRUPTIONS	53
9. PHOTOGRAPHS OF THE TEST CONFIGURATION	55
10. PHOTOGRAPHS OF EUT	59



1. TEST CERTIFICATION

Product:	ROBOT VACUUM CLEANER
Model:	KRV305A,KRV305B
Applicant :	.
Address:	
Manufacturer:	
Address:	
Test Date:	November 29, 2022 to December 03, 2022
Issued Date:	December 05, 2022
Test Voltage:	AC 230V/50Hz
Applicable Standards:	EMC Directive 2014/30/EU EN IEC 55014-1:2021 EN IEC 55014-2:2021 EN IEC 61000-3-2:2019+A1:2021 EN 61000-3-3:2013+A1:2019

The above equipment has been tested by Precise Testing & Certification (Guangdong) Co., Ltd. and found compliance with the requirements in the technical standards mentioned above. The test results presented in this report only relate to the product/system tested. The Other similar equipment will not necessarily produce the same results due to production tolerance and measurement uncertainties.

Test Engineer:

Technical Manager:



Abel Yu / Engineer

Ronnie Liu / Manager



2. TEST SUMMARY

EMISSION			
Standard	Item	Result	Remarks
EN IEC 55014-1: 2021	Conducted (Main Port)	PASS	Complied with limit
	Disturbance Power	N/A	N/A
	Radiated Emission	PASS	Complied with limit
	Click	N/A	N/A
EN IEC 61000-3-2:2019+A1:2021	Harmonic current emissions	N/A	N/A
EN 61000-3-3:2013+A1:2019	Voltage fluctuations & flicker	PASS	Complied with limit

IMMUNITY			
Standard	Item	Result	Remarks
IEC 61000-4-2:2008	ESD	PASS	Complied with the requirements
IEC 61000-4-3:2006+A1:2007+A2:2010	RS	PASS	Complied with the requirements
IEC 61000-4-4:2012	EFT	PASS	Complied with the requirements
IEC 61000-4-5:2014+A1:2017	Surge	PASS	Complied with the requirements
IEC 61000-4-6:2013	CS	PASS	Complied with the requirements
IEC 61000-4-11:2020	Voltage dips & voltage variations	PASS	Complied with the requirements

Note: 1) The test result verdict is decided by the limit of test standard.

2) The information of measurement uncertainty is available upon the customer's request.



3. TEST SITE

3.1. TEST FACILITY

Precise Testing & Certification (Guangdong) Co., Ltd.

Address: Building 1, No. 6, Tongxin Road, Dongcheng Street, Dongguan, Guangdong, China.

- ☆ CNAS Registration No.: CNAS L5772
- ☆ FCC Registration No.: 790290
- ☆ A2LA Certificate No.: 4408.01
- ☆ IC Registration No.: 12191A

3.2. Measurement Uncertainty

Parameter	Uncertainty
Temperature	$\pm 1^{\circ} \text{C}$
Humidity	$\pm 5\%$
DC and Low Frequency Voltages	$\pm 3\%$
Conducted Emission(150KHz-30MHz)	$\pm 3.60\text{dB}$
Radiated Emission(30MHz-1GHz)	$\pm 4.76\text{dB}$
Radiated Emission (1GHz-18GHz)	$\pm 4.44\text{dB}$

Note 1: This uncertainty represents an expanded uncertainty expressed at approximately the 95% confidence level using a coverage factor of k=2.



3.3. LIST OF TEST AND MEASUREMENT INSTRUMENTS

3.3.1. For conducted emission at the mains terminals test

Name of Equipment	Manufacturer	Model	Serial No.	Calibration Due
EMI Test Receiver	Rohde&Schwarz	ESCI	101417	Aug 21, 2023
Artificial Mains Network	Rohde&Schwarz	ENV216	102453	Aug 21, 2023
ISN	SCHWARZBECK	NTFM8131	00257	Aug 21, 2023
Test S/W	Tonscend	JS32-CE/4.0.0.3		

3.3.2. For click test (DQT)

Name of Equipment	Manufacturer	Model	Serial No.	Calibration Due
Click Tester	SCHWARZBECK	DIA1512D	21554	Aug 21, 2023
Artificial Mains Network	SCHWARZBECK	NSLK8126	8126415	Aug 21, 2023

3.3.3. For disturbance power test

Name of Equipment	Manufacturer	Model	Serial No.	Calibration Due
EMI Test Receiver	Rohde&Schwarz	ESCI	101417	Aug 21, 2023
Absorbing Clamp	LUTHI	MDS 21B	P1407131815	Aug 21, 2023
Test S/W	Tonscend	JS32-CE/4.0.0.3		

3.3.4. For radiated emission test (30MHz-1GHz)

Name of Equipment	Manufacturer	Model	Serial No.	Calibration Due
EMI Test Receiver	Rohde&Schwarz	ESCI	101417	Aug 21, 2023
Bilog Antenna	SCHWARZBECK	VULB 9160	9160-3355	Aug 21, 2023
Preamplifier (low frequency)	SCHWARZBECK	BBV 9475	9745-0013	Aug 21, 2023



Test S/W	Tonscend	JS32-RE/4.0.0.0
----------	----------	-----------------

3.3.5. For harmonic current emissions and voltage fluctuations/flicker test

Name of Equipment	Manufacturer	Model	Serial No.	Calibration Due
Harmonics / Flicker Test System	California Instruments	CTS/PACS-1-115	1534A00401	Aug 21, 2023
AC Power Source	California Instruments	3001IX-208-CTS	1534A00401	Aug 21, 2023
Test S/W	AMETEK	CTS 4		

3.3.6. For electrostatic discharge immunity test

Name of Equipment	Manufacturer	Model	Serial No.	Calibration Due
ESD Generator	SCHLODER	SESD216	606137	Aug 21, 2023

3.3.7. For radio frequency electromagnetic field immunity (R/S) test

Name of Equipment	Manufacturer	Model	Serial No.	Calibration Due
Power meter	Agilent	E4419B	GB42421440	Aug 21, 2023
Isotropic Field Probe	Narda	EP-601	611WX80275	Aug 21, 2023
Amplifier	SKET	HAP_801000M-250W	201811050	Aug 21, 2023
Amplifier	SKET	HAP_0103G-75W	201811051	Aug 21, 2023
Amplifier	SKET	HAP_0306G-20W	201811052	Aug 21, 2023
Log-periodic Antenna	SKET	ZDSZ-80T1000M-231	SKT231015	Aug 21, 2023
Log-periodic Antenna	SKET	ZDSZ-1T6G-232	SKT232079	Aug 21, 2023

**3.3.8. For electrical fast transient/burst immunity test**

Name of Equipment	Manufacturer	Model	Serial No.	Calibration Due
EFT Tester	HTEC	HV1P16T/HCOM PACT52	170901/190901	Aug 21, 2023
EFT Coupling Clamp	HTEC	HEFT 51-C	1416011	Aug 21, 2023

3.3.9. For surge immunity test

Name of Equipment	Manufacturer	Model	Serial No.	Calibration Due
Surge Tester	HTEC	HCWG 71	174302	Aug 21, 2023
Surge Tester	HTEC	TCOMB 4	142103	Aug 21, 2023
Surge Tester	HTEC	HTSG 70	175002	Aug 21, 2023

3.3.10. For injected currents susceptibility test

Name of Equipment	Manufacturer	Model	Serial No.	Calibration Due
C/S Test System	SCHLODER	CDG-6000-25	126A1279/2014	Aug 21, 2023
Coupling Decoupling Network	SCHLODER	CDN-M2+3	A2210251/2013	Aug 21, 2023
Electromagnetic Injection Clamp	Luthi	EM101	36041	Aug 21, 2023
Test S/W	SCHLODER	CDG/1.0.0.0		

3.3.11. For voltage dips and short interruptions immunity test

Name of Equipment	Manufacturer	Model	Serial No.	Calibration Due
Dips Tester	HTEC	HV1P16T/HCOM PACT52	170901/190901	Aug 21, 2023



4. EUT DESCRIPTION

Product	ROBOT VACUUM CLEANER
Model	KRV305A,KRV305B
Power Supply	<p>MODEL:KRV305A LI-ION BATTERY:14.8V$\overline{\text{---}}$2000mAh INPUT:19V$\overline{\text{---}}$0.6A</p> <p>MODEL:KRV305B LI-ION BATTERY:11.1V$\overline{\text{---}}$1500mAh INPUT:14V$\overline{\text{---}}$0.6A</p>
Adapter	<p>KRV305A Model:JYH7Z-1900060-BE,JYH7Z-1900060-BG Input:100-240V~ 50/60Hz 0.5A Output:19.0V$\overline{\text{---}}$0.6A 11.4W Manufacturer:Shenzhen Juyuanhai Electronic Co.,Ltd.</p> <p>KRV305B Model:JYH7Z-1400060-BE,JYH7Z-1400060-BG Input:100-240V~ 50/60Hz 0.5A Output:14.0V$\overline{\text{---}}$0.6A 8.4W Manufacturer:Shenzhen Juyuanhai Electronic Co.,Ltd.</p>
Power	16W

I/O PORT

I/O PORT TYPES	Q'TY	TESTED WITH
AC Port	1	<input checked="" type="checkbox"/>
DC Port	1	<input checked="" type="checkbox"/>

Models Difference

N/A.



5. TEST METHODOLOGY

5.1. TEST MODE

The EUT was tested together with the thereafter additional components, and a configuration, which produced the worst emission levels, was selected and recorded in this report.

The following test mode(s) were assessed.

	Test Items	Test Mode
Emission	Conducted Emission	Charging
	Disturbance Power	N/A
	Radiated Emission	Charging/Working
	Harmonic current emissions	N/A
	Voltage fluctuations & flicker	Charging
Immunity	ESD	Charging/Working
	RS	Charging/Working
	EFT	Charging
	Surge	Charging
	C/S	Charging
	Dips	Charging

5.2. EUT SYSTEM OPERATION

1. Set up EUT with the support equipment.
2. Make sure the EUT work normally during the test.



6. SETUP OF EQUIPMENT UNDER TEST

6.1. DESCRIPTION OF SUPPORT UNITS

The EUT has been tested as an independent unit together with other necessary accessories or support units. The following support units or accessories were used to form a representative test configuration during the tests.

No.	Equipment	Model	Serial No.	FCC ID	Trade Name	Data Cable	Power Cord
1.	N/A	N/A	N/A	N/A	N/A	N/A	N/A

Note: 1) All the equipment/cables were placed in the worst-case configuration to maximize the emission during the test.

2) Grounding was established in accordance with the manufacturer's requirements and conditions for the intended use.

6.2. CONFIGURATION OF SYSTEM UNDER TEST

Charging:

Working:

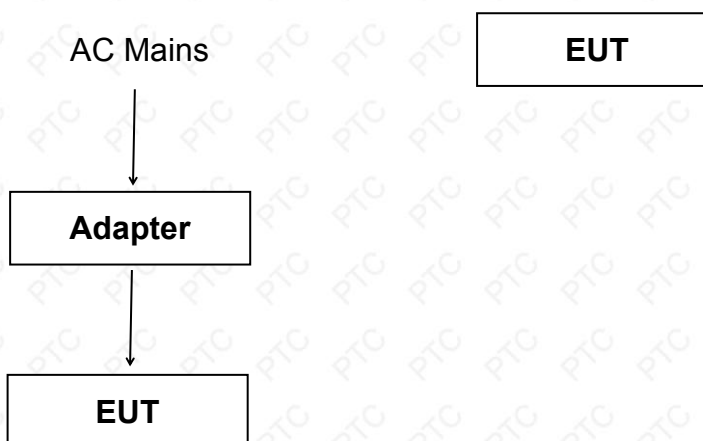

(EUT: ROBOT VACUUM CLEANER)



7. EMISSION TEST

7.1. CONDUCTED EMISSION MEASUREMENT

7.1.1. LIMITS

Household appliances and equipment causing similar disturbances
and regulation controls incorporation semiconductor devices

FREQUENCY (MHz)	At mains terminals		At load terminals and additional terminals	
	Quasi-peak dB μ V	Average dB μ V	Quasi-peak dB μ V	Average dB μ V
0.15 - 0.5	66-56	59-46	80	70
0.5 - 5.0	56	46	74	64
5.0 - 30.0	60	50	74	64

Mains terminals of tools

FREQUENCY (MHz)	Rated motor power not exceeding 700W		Rated motor power above 700W and not exceeding 1000W		Rated motor power above 1000W	
	Quasi-peak dB μ V	Average dB μ V	Quasi-peak dB μ V	Average dB μ V	Quasi-peak dB μ V	Average dB μ V
0.15 - 0.35	66-59	59-49	70-63	63-53	79-69	69-59
0.35 - 5.0	59	49	63	53	69	59
5.0 - 30.0	64	54	68	58	74	64

Note: 1) The lower limit shall apply at the transition frequencies.

2) Decreasing linearly with the logarithm of the frequency.

7.1.2. TEST PROCEDURES

The EUT and Support equipment, if needed, was set up as per the test configuration to simulate typical usage per the user's manual. When the EUT is a tabletop system, a wooden table with a height of 0.8 meters is used and is placed on the ground plane. When the EUT is floor standing equipment, it is placed on the ground plane, which has a 3-12 mm non-conductive covering to insulate the EUT from the ground plane. The EUT should be 0.8m apart from the AMN, where the mains cable supplied by the manufacturer is longer than 0.8 m, the excess should be folded at the centre into a bundle no longer than 0.4 m, Details please refer to test setup photography.

The Receiver scanned from 150 kHz to 30 MHz for emissions in each of the test modes. During the above scans, the emissions were maximized by cable manipulation.

A scan was taken on both power lines, Line and Neutral, recording at least the six highest

emissions. Emission frequency and amplitude were recorded into a computer in which correction factors were used to calculate the emission level and compare reading to the applicable limit. The test data of the worst-case condition(s) was recorded.
 Note: Test Software Name: e3, Software Version: 1.0.0.0.

7.1.3. TEST SETUP

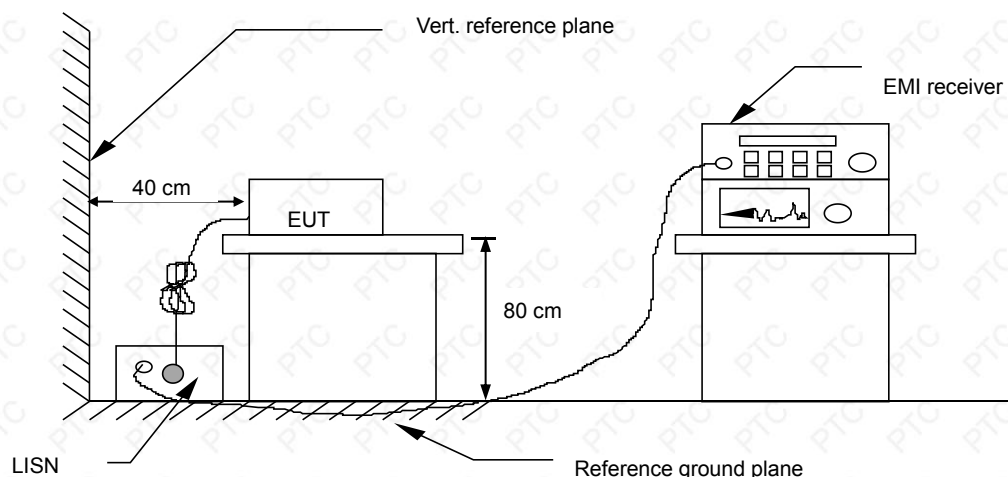

For the actual test configuration, please refer to the related item – Photographs of the Test Configuration.

7.1.4. TEST RESULT

Product name	ROBOT VACUUM CLEANER	Tested By	Mi Jiawei
Model	KRV305A,KRV305B	Detector Function	Quasi-peak/AV
Test Mode	Charging	6 dB Bandwidth	9 kHz
Environmental Conditions	25°C, 60 % RH, 101.5 kPa	Test Result	Pass

Note:
 L = Line Line, N = Neutral Line
 Freq. = Emission frequency in MHz
 Reading level (dB μ V) = Receiver reading
 Corr. Factor (dB) = attenuator + Cable loss
 Level (dB μ V) = Reading level (dB μ V) + Corr. Factor (dB)
 Limit (dB μ V) = Limit stated in standard
 Over Limit (dB) = Level (dB μ V) – Limit (dB μ V)
 QP = Quasi-Peak
 AV = Average



Please refer to the following diagram:

Line:KRV305B

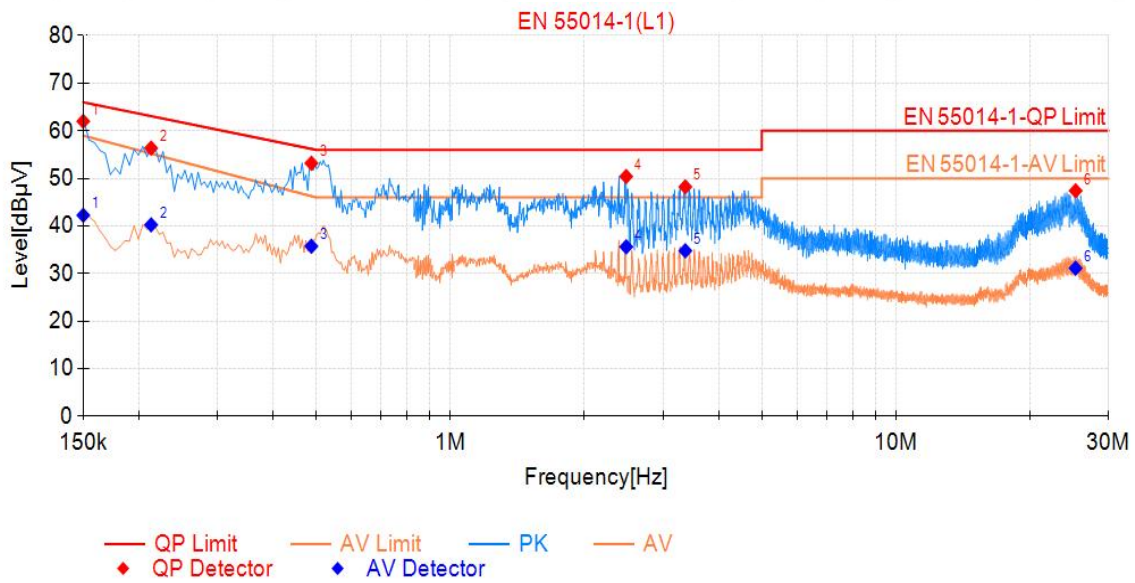

Final Data List								
NO.	Freq. [MHz]	QP Value [dBµV]	QP Limit [dBµV]	QP Margin [dB]	AV Value [dBµV]	AV Limit [dBµV]	AV Margin [dB]	Verdict
1	0.150	62.00	66.00	4.00	42.26	59.00	16.74	PASS
2	0.213	56.36	63.09	6.73	40.25	55.21	14.96	PASS
3	0.488	53.19	56.21	3.02	35.75	46.27	10.52	PASS
4	2.481	50.41	56.00	5.59	35.62	46.00	10.38	PASS
5	3.368	48.23	56.00	7.77	34.80	46.00	11.20	PASS
6	25.305	47.40	60.00	12.60	31.13	50.00	18.87	PASS



Neutral:

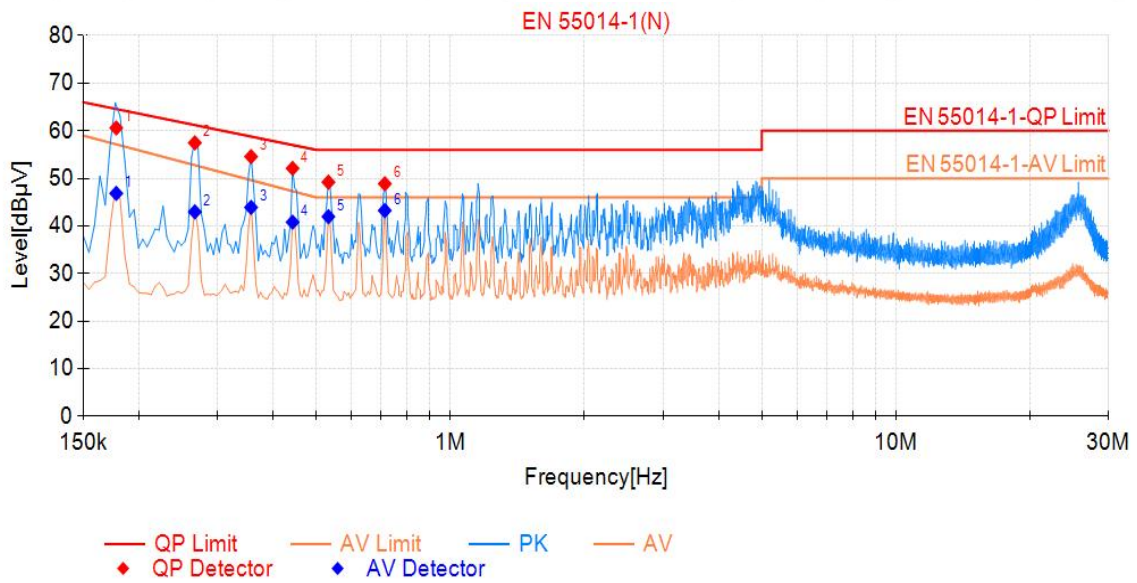

Final Data List								
NO.	Freq. [MHz]	QP Value [dBµV]	QP Limit [dBµV]	QP Margin [dB]	AV Value [dBµV]	AV Limit [dBµV]	AV Margin [dB]	Verdict
1	0.178	60.61	64.59	3.98	46.85	57.16	10.31	PASS
2	0.267	57.48	61.21	3.73	42.97	52.77	9.80	PASS
3	0.357	54.58	58.80	4.22	43.91	49.64	5.73	PASS
4	0.443	52.12	57.01	4.89	40.80	47.32	6.52	PASS
5	0.533	49.21	56.00	6.79	41.96	46.00	4.04	PASS
6	0.713	48.87	56.00	7.13	42.93	46.00	3.07	PASS



Line:KRV305A

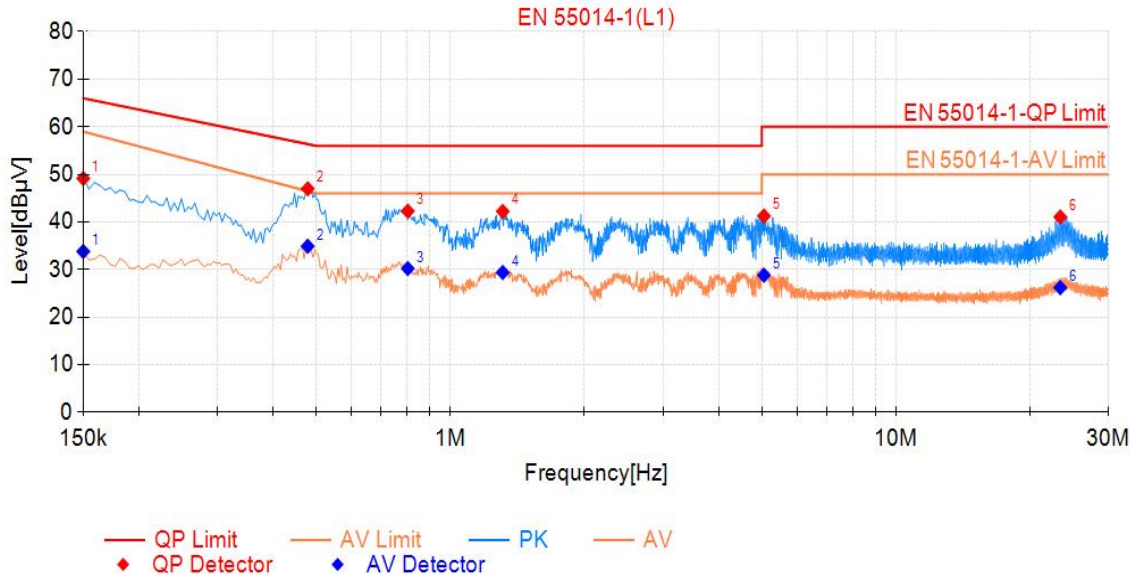

Final Data List

NO.	Freq. [MHz]	QP Value [dBµV]	QP Limit [dBµV]	QP Margin [dB]	AV Value [dBµV]	AV Limit [dBµV]	AV Margin [dB]	Verdict
1	0.150	49.15	66.00	16.85	33.80	59.00	25.20	PASS
2	0.479	46.99	56.37	9.38	34.91	46.47	11.56	PASS
3	0.803	42.29	56.00	13.71	30.21	46.00	15.79	PASS
4	1.311	42.23	56.00	13.77	29.39	46.00	16.61	PASS
5	5.055	41.24	60.00	18.76	28.82	50.00	21.18	PASS
6	23.379	41.05	60.00	18.95	26.21	50.00	23.79	PASS



Neutral:

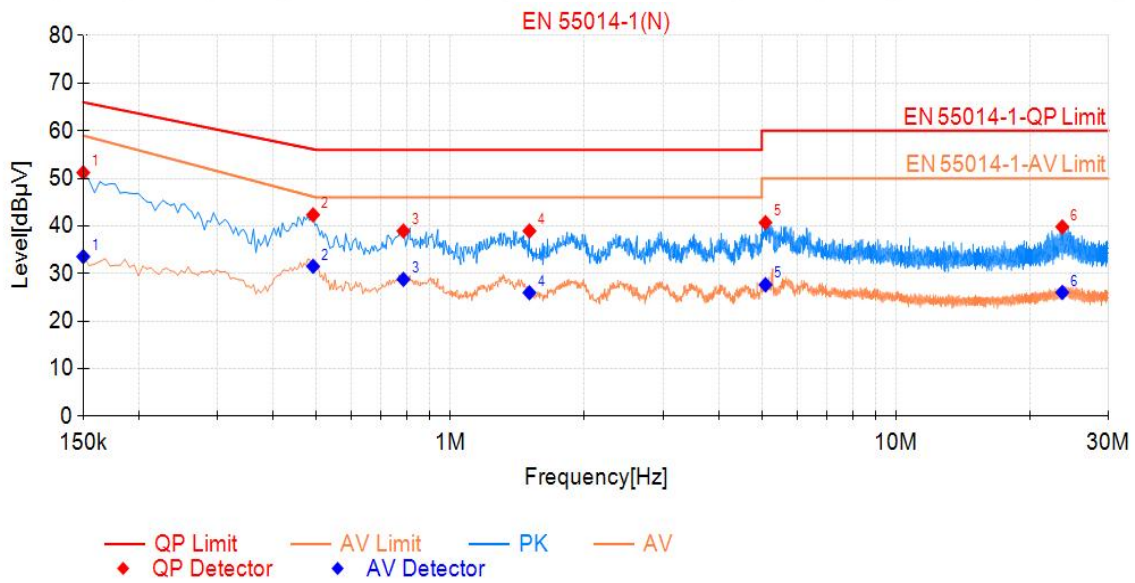

Final Data List								
NO.	Freq. [MHz]	QP Value [dBµV]	QP Limit [dBµV]	QP Margin [dB]	AV Value [dBµV]	AV Limit [dBµV]	AV Margin [dB]	Verdict
1	0.150	51.21	66.00	14.79	33.57	59.00	25.43	PASS
2	0.492	42.34	56.13	13.79	31.53	46.17	14.64	PASS
3	0.785	38.95	56.00	17.05	28.78	46.00	17.22	PASS
4	1.505	38.95	56.00	17.05	25.97	46.00	20.03	PASS
5	5.096	40.71	60.00	19.29	27.66	50.00	22.34	PASS
6	23.622	39.81	60.00	20.19	26.03	50.00	23.97	PASS



7.2. CLICK MEASUREMENT

7.2.1. LIMITS

The click limit L_q is determined from the formula:

$$L_q = L + \Delta L$$

which the limits L for continuous disturbance shall be increased (see table 1):

which corresponding to the click rate N shall be calculated the amount ΔL by

$$\Delta L = 44 \text{ dB for } N < 0,2$$

$$\Delta L = [20 \log(30/N)] \text{ dB for } 0,2 \leq N < 30$$

Table 1

FREQUENCY (MHz)	At mains terminals		At load terminals and additional terminals	
	Quasi-peak dB μ V	Average dB μ V	Quasi-peak dB μ V	Average dB μ V
0.15 - 0.5	66-56	59-46	80	70
0.5 - 5.0	56	46	74	64
5.0 - 30.0	60	50	74	64

7.2.2. TEST PROCEDURE

The EUT and Support equipment, if needed, was set up as per the test configuration to simulate typical usage per the user's manual. When the EUT is a tabletop system, a wooden table with a height of 0.8 meters is used and is placed on the ground plane. When the EUT is floor standing equipment, it is placed on the ground plane, which has a 3-12 mm non-conductive covering to insulate the EUT from the ground plane. The EUT should be 0.8 m apart from the AMN, where the mains cable supplied by the manufacturer is longer than 1m, the excess should be folded at the centre into a bundle no longer than 0.4 m, Details please refer to test setup photography.

At first, determining N by measuring the Clicks, calculating the limit.

Then, use the Upper quartile method to confirm EUT is fulfilled the requirement of standard or not.

The amplitude of the clicks shall be evaluated only at the following restricted number of frequencies: 150 kHz; 500 kHz; 1.4 MHz and 30 MHz

7.2.3. TEST SETUP

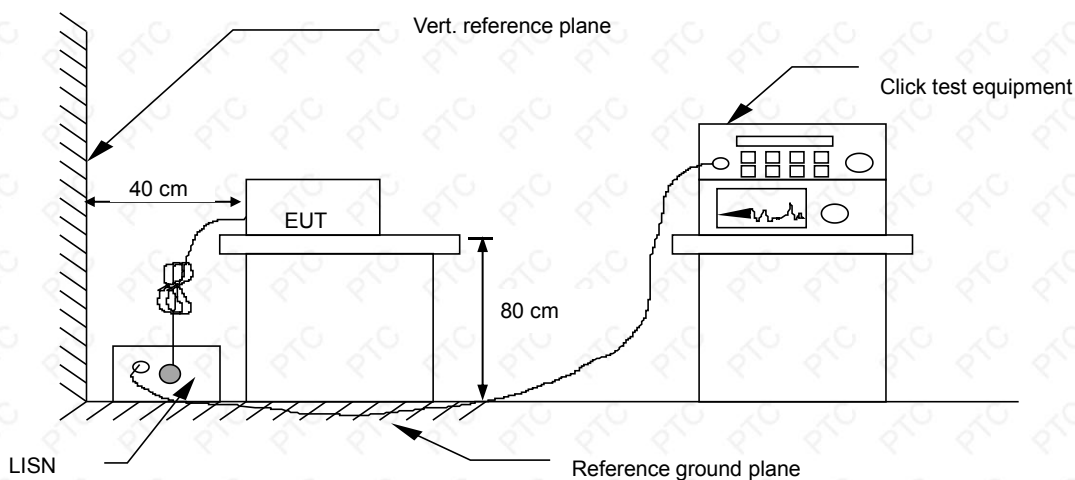

For the actual test configuration, please refer to the related item – Photographs of the Test Configuration

7.2.4. TEST RESULT

This test is not applicable because the EUT does not have the relative function.



7.3. DISTURBANCE POWER MEASUREMENT

7.3.1. LIMITS

FREQUENCY (MHz)	Household appliances and similar appliances		Rated motor power not exceeding 700W		Rated motor power above 700W and not exceeding 1000W		Rated motor power above 1000W	
	QP dBpW	Average dBpW	QP dBpW	Average dBpW	QP dBpW	Average dBpW	QP dBpW	Average dBpW
30 ~ 300	45-55	35-45	45-55	35-45	49-59	39-49	55-65	45-55
FREQUENCY (MHz)	Household appliances and similar appliances		Rated motor power not exceeding 700W		Rated motor power above 700W and not exceeding 1000W		Rated motor power above 1000W	
	QP dBpW	Average dBpW	QP dBpW	Average dBpW	QP dBpW	Average dBpW	QP dBpW	Average dBpW
200 ~ 300	0 to 10 dB		0 to 10 dB		0 to 10 dB		0 to 10 dB	

- Note: 1) The lower limit shall apply at the transition frequencies.
 2) Increasing linearly with the frequency.
 3) QP means Quasi-peak, AV means Average.
 4) The limit of column 2 and 3 apply to this product.

7.3.2. TEST PROCEDURE

The EUT is placed on a 0.8 meters height wooden table above the ground plane, and kept at least 0.8 m from other metallic object. The straight portion of lead would put on 6 m long testing bench of (if lead is shorter than 6 m it should be extended)

Any lead connecting the main appliance to an auxiliary apparatus is disconnected if this does not affect the operation of the appliance, or is isolated by means of ferrite rings (or an absorbing clamp) close to the appliance.

The receiver scanned from 30 MHz to 300 MHz. Emissions were scanned and measured to moving the absorbing clamp along the main lead until the maximum emission value is found. Recorded at least the six highest emissions.

The test data of the worst-case condition(s) was recorded.

Note: Test Software Name: e3, Software Version: 1.0.0.0.

7.3.3. TEST SETUP

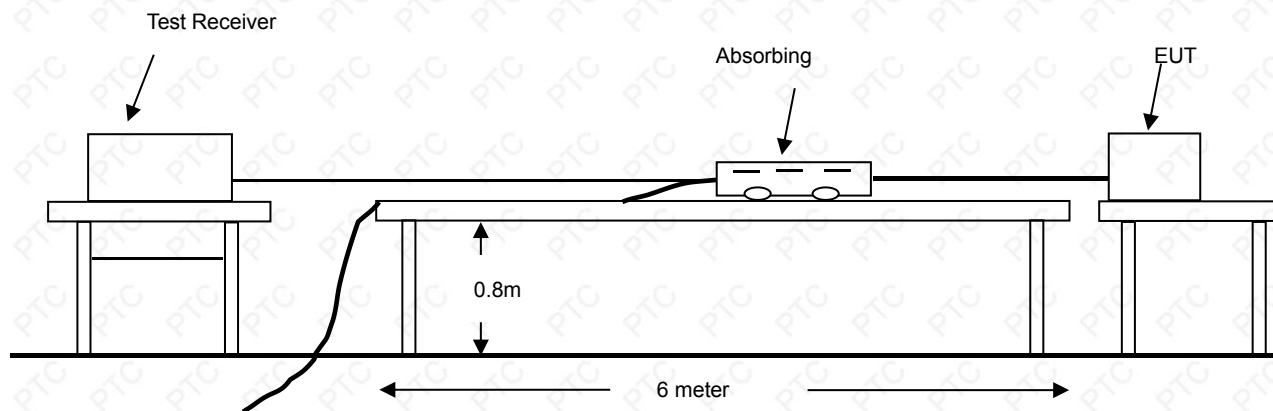

For the actual test configuration, please refer to the related item – Photographs of the Test Configuration

7.3.4. TEST RESULT

N/A



7.4. RADIATED EMISSION MEASUREMENT

7.4.1. LIMITS

FREQUENCY (MHz)	Limit (dB μ V/m) (At 3m)
30 ~ 230	40
230 ~ 1000	47

Note: 1) The lower limit shall apply at the transition frequencies.

2) Emission level (dB μ V/m) = 20 log Emission level (μ V/m).

7.4.2. TEST PROCEDURE

The equipment was set up as per the test configuration to simulate typical usage per the user's manual. When the EUT is a tabletop system, a wooden turntable with a height of 0.8 meters is used which is placed on the ground plane. When the EUT is floor standing equipment, it is placed on the ground plane which has a 0.1 m non-conductive covering to insulate the EUT from the ground plane.

The antenna was placed at 3 meter away from the EUT. The antenna connected to the spectrum analyzer via a cable and at times a pre-amplifier would be used.

The analyzer / receiver quickly scanned from 30 MHz to 1000 MHz. The EUT test program was started. Emissions were scanned and measured rotating the EUT to 360 degrees and positioning the antenna 1 to 4 meters above the ground plane, in both the vertical and the horizontal polarization, to maximize the emission reading level.

During the above scans, the emissions were maximized by cable manipulation. Each modes is measured, recorded at least the six highest emissions. The emission frequency, amplitude, antenna position, polarization and turntable position were recorded into a computer in which correction factors were used to calculate the emission level and compare reading to the applicable limit and only Q.P. reading is presented.

The test data of the worst-case condition(s) was recorded.

Note: Test Software Name: e3, Software Version: 8.2.1.0.

7.4.3. TEST SETUP

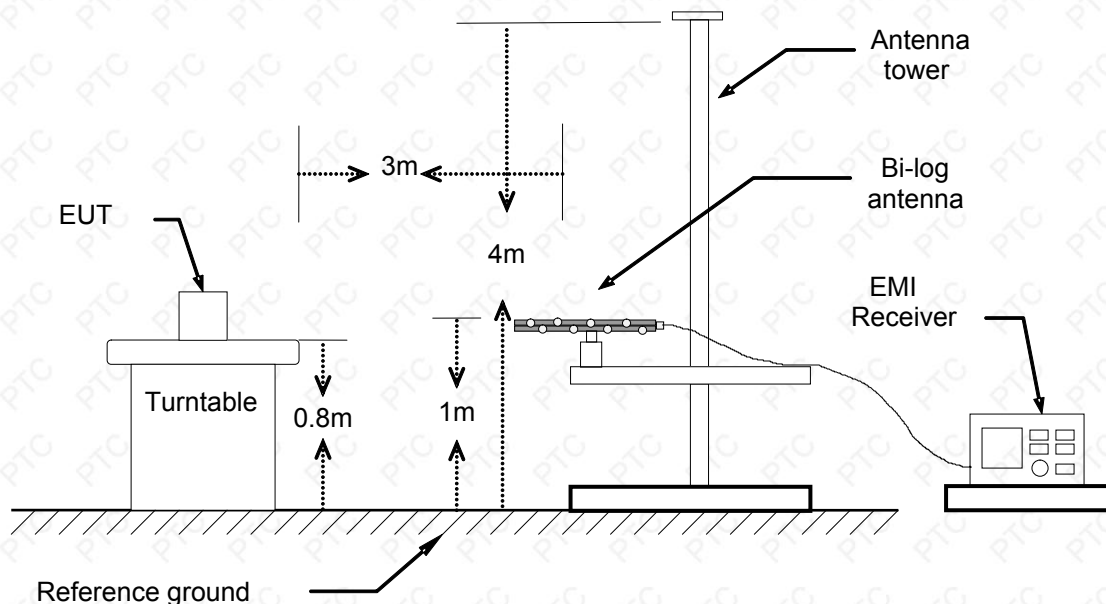

For the actual test configuration, please refer to the related item – Photographs of the Test Configuration

7.4.4. TEST RESULT

Product name	ROBOT VACUUM CLEANER	Antenna Distance	3 m
Model	KRV305A,KRV305B	Antenna Pole	Vertical / Horizontal
Test Mode	Charging/Working	Detector Function	Quasi-peak
Environmental Conditions	25°C, 60 % RH, 101.5 kPa	6 dB Bandwidth	120 kHz
Tested by	MING ZHI	Test Result	Pass

Note:

Freq. = Emission frequency in MHz

Reading level (dB μ V) = Receiver reading(dB μ V)

Corr.Factor (dB/m)=Antenna factor(dB/m)+Cable loss(dB)-Preamp Factor(dB)

Measurement (dB μ V/m)=Reading level(dB μ V)+ Corr. Factor (dB/m)

Limit (dB μ V/m) = Limit stated in standard

Over Limit (dB) = Measurement (dB μ V/m) – Limit (dB μ V/m)

QP = Quasi-Peak



Please refer to the following diagram:
Vertical:KRV305A CHARGING

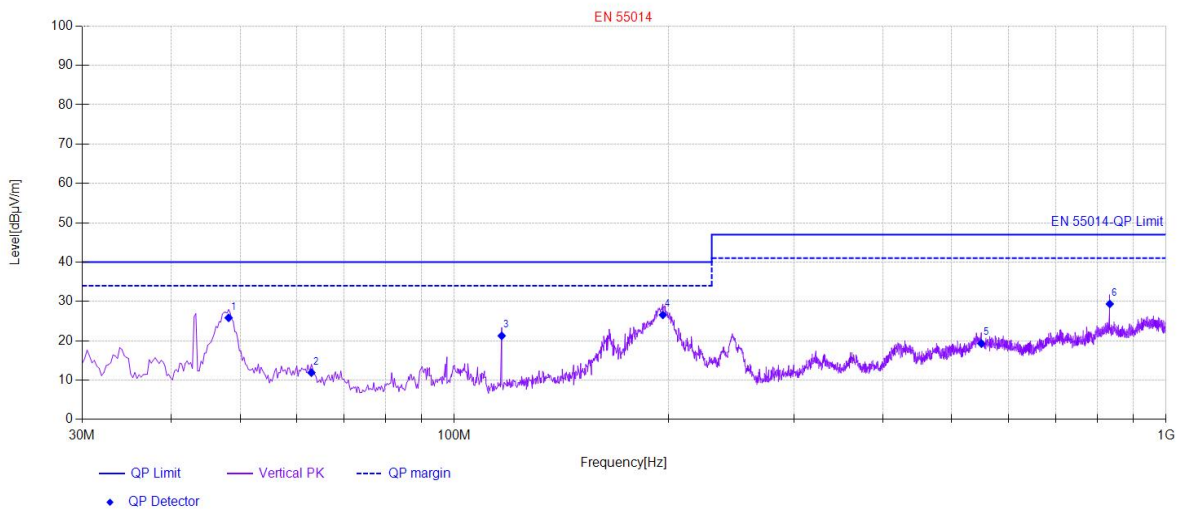

Final Data List[QP]							
NO.	Freq. [MHz]	QP Reading [dBµV/m]	Factor [dB]	QP Value [dBµV/m]	QP Limit [dBµV/m]	QP Margin [dB]	Polarity
1	48.19	43.55	-17.71	25.84	40.00	14.16	Vertical
2	62.98	30.15	-18.25	11.90	40.00	28.10	Vertical
3	116.57	39.65	-18.39	21.26	40.00	18.74	Vertical
4	196.36	45.14	-18.57	26.57	40.00	13.43	Vertical
5	550.16	28.69	-9.38	19.31	47.00	27.69	Vertical
6	833.65	33.29	-3.93	29.36	47.00	17.64	Vertical



Horizontal:

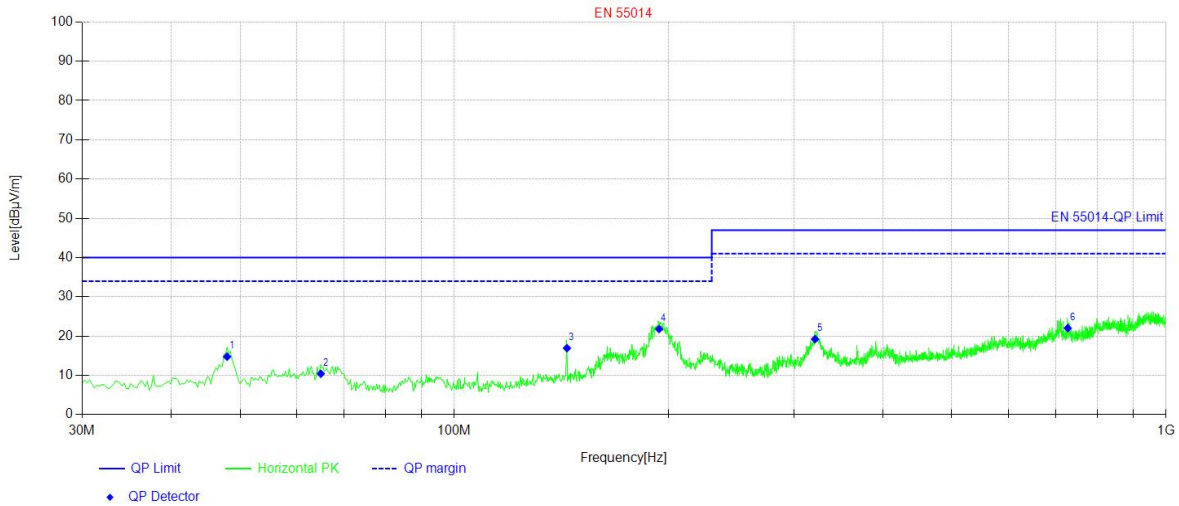

Final Data List[QP]							
NO.	Freq. [MHz]	QP Reading [dBµV/m]	Factor [dB]	QP Value [dBµV/m]	QP Limit [dBµV/m]	QP Margin [dB]	Polarity
1	47.95	32.46	-17.69	14.77	40.00	25.23	Horizontal
2	64.92	28.98	-18.55	10.43	40.00	29.57	Horizontal
3	143.98	33.4	-16.46	16.94	40.00	23.06	Horizontal
4	193.93	40.2	-18.39	21.81	40.00	18.19	Horizontal
5	321.24	34.06	-14.83	19.23	47.00	27.77	Horizontal
6	727.67	28	-5.97	22.03	47.00	24.97	Horizontal



Vertical:KRV305A WORKING

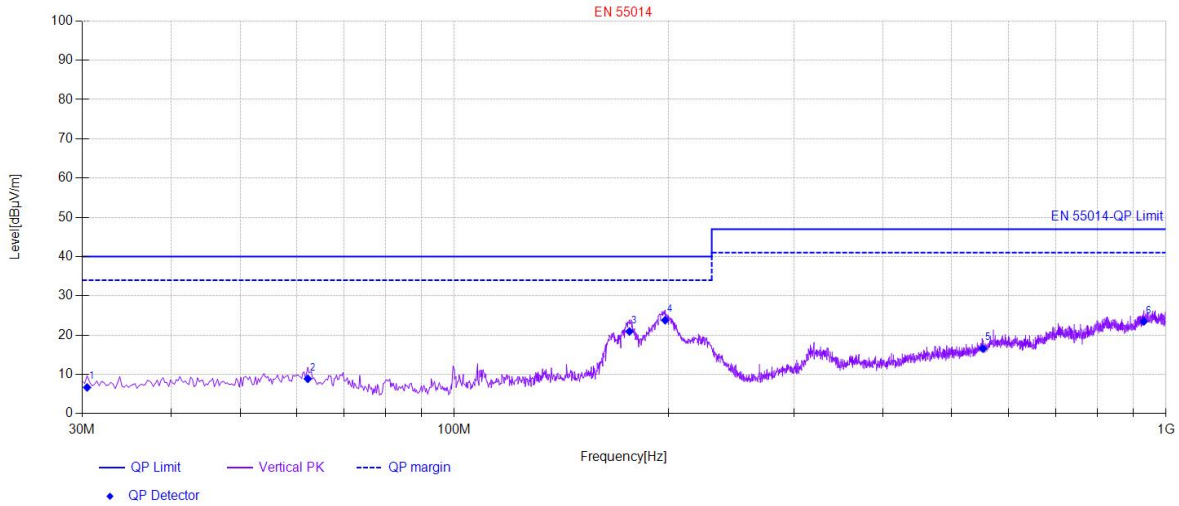

Final Data List[QP]							
NO.	Freq. [MHz]	QP Reading [dBµV/m]	Factor [dB]	QP Value [dBµV/m]	QP Limit [dBµV/m]	QP Margin [dB]	Polarity
1	30.49	25	-18.32	6.68	40.00	33.32	Vertical
2	62.25	27.01	-18.14	8.87	40.00	31.13	Vertical
3	176.23	37.72	-16.79	20.93	40.00	19.07	Vertical
4	197.81	42.47	-18.68	23.79	40.00	16.21	Vertical
5	553.07	25.91	-9.34	16.57	47.00	30.43	Vertical
6	930.89	25.97	-2.47	23.50	47.00	23.50	Vertical



Horizontal:

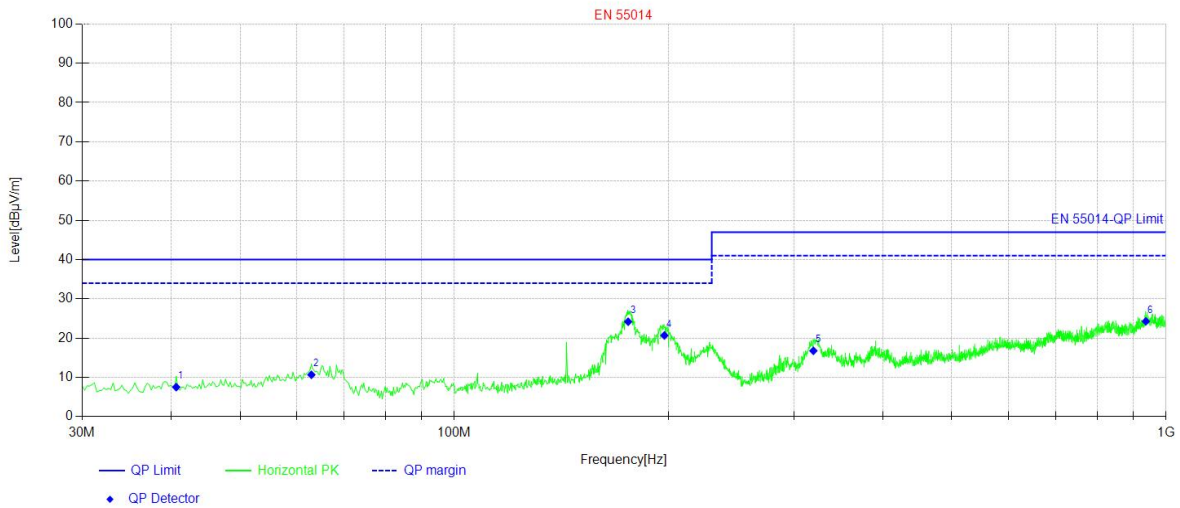

Final Data List[QP]							
NO.	Freq. [MHz]	QP Reading [dBµV/m]	Factor [dB]	QP Value [dBµV/m]	QP Limit [dBµV/m]	QP Margin [dB]	Polarity
1	40.67	25.25	-17.72	7.53	40.00	32.47	Horizontal
2	62.98	28.92	-18.25	10.67	40.00	29.33	Horizontal
3	175.50	40.91	-16.72	24.19	40.00	15.81	Horizontal
4	197.33	39.32	-18.64	20.68	40.00	19.32	Horizontal
5	319.55	31.65	-14.88	16.77	47.00	30.23	Horizontal
6	936.71	26.71	-2.42	24.29	47.00	22.71	Horizontal



Vertical:KRV305B CHARGING

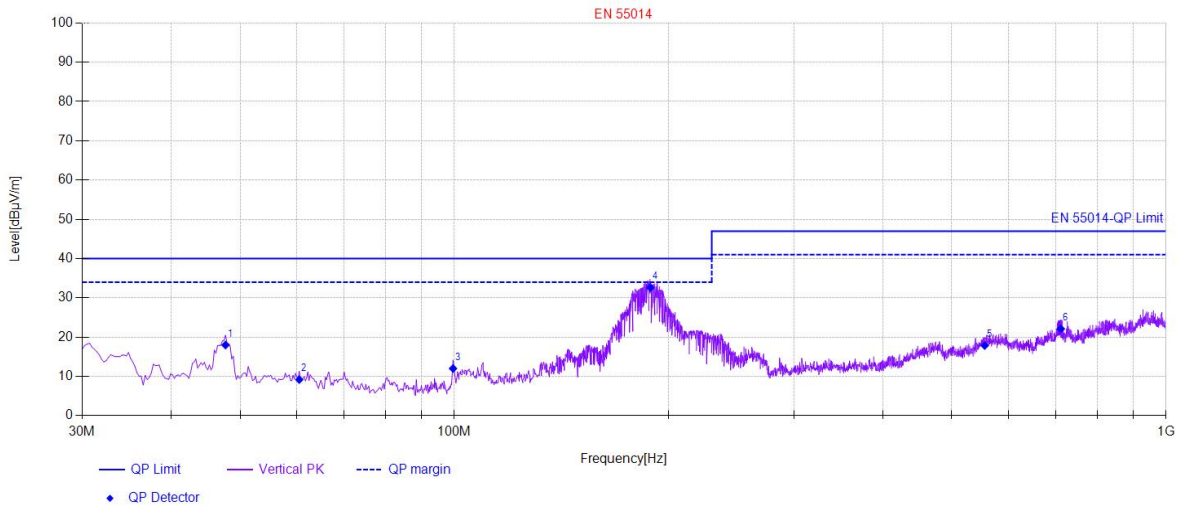

Final Data List[QP]							
NO.	Freq. [MHz]	QP Reading [dBµV/m]	Factor [dB]	QP Value [dBµV/m]	QP Limit [dBµV/m]	QP Margin [dB]	Polarity
1	47.70	35.65	-17.66	17.99	40.00	22.01	Vertical
2	60.56	27.06	-17.88	9.18	40.00	30.82	Vertical
3	99.60	31.73	-19.72	12.01	40.00	27.99	Vertical
4	188.60	50.6	-17.99	32.61	40.00	7.39	Vertical
5	556.23	27.15	-9.30	17.85	47.00	29.15	Vertical
6	711.67	28.44	-6.34	22.10	47.00	24.90	Vertical



Horizontal:

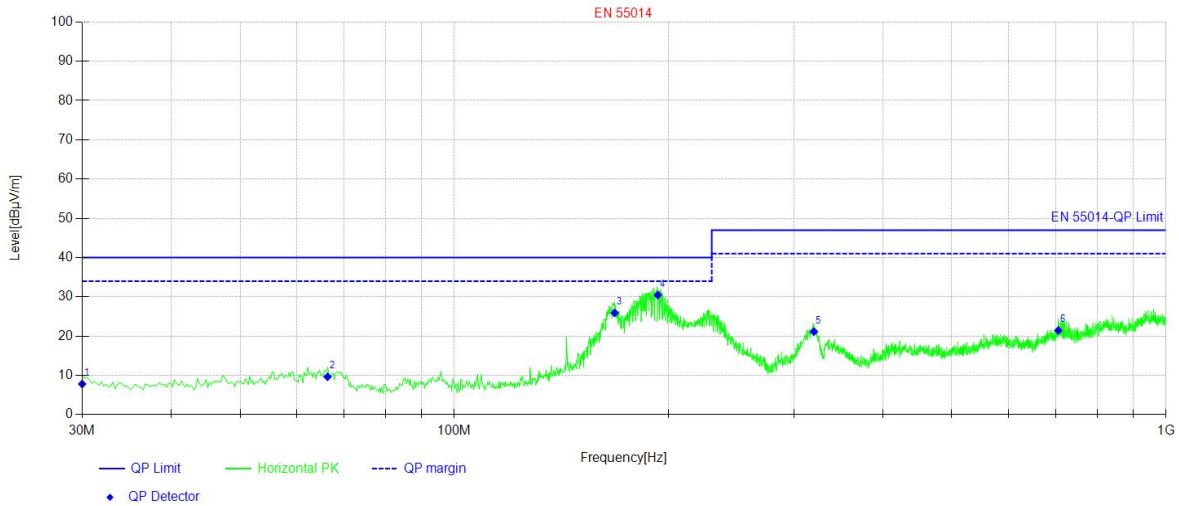

Final Data List[QP]							
NO.	Freq. [MHz]	QP Reading [dBµV/m]	Factor [dB]	QP Value [dBµV/m]	QP Limit [dBµV/m]	QP Margin [dB]	Polarity
1	30.00	26.17	-18.35	7.82	40.00	32.18	Horizontal
2	66.38	28.4	-18.74	9.66	40.00	30.34	Horizontal
3	167.98	42.06	-16.15	25.91	40.00	14.09	Horizontal
4	193.20	48.79	-18.33	30.46	40.00	9.54	Horizontal
5	320.03	36.01	-14.86	21.15	47.00	25.85	Horizontal
6	705.61	27.91	-6.47	21.44	47.00	25.56	Horizontal



Vertical:KRV305B WORKING

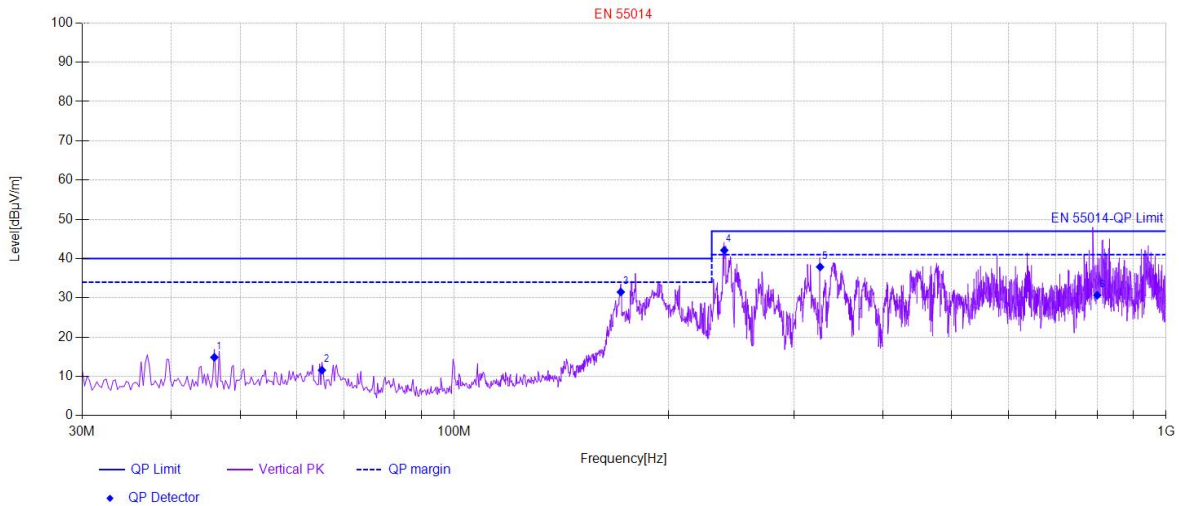

Final Data List[QP]							
NO.	Freq. [MHz]	QP Reading [dBµV/m]	Factor [dB]	QP Value [dBµV/m]	QP Limit [dBµV/m]	QP Margin [dB]	Polarity
1	46.01	32.27	-17.41	14.86	40.00	25.14	Vertical
2	65.16	30.16	-18.58	11.58	40.00	28.42	Vertical
3	171.38	47.88	-16.40	31.48	40.00	8.52	Vertical
4	239.52	59.79	-17.66	42.13	47.00	4.87	Vertical
5	326.58	52.54	-14.67	37.87	47.00	9.13	Vertical
6	800.59	35.33	-4.66	30.67	47.00	16.33	Vertical



Horizontal:

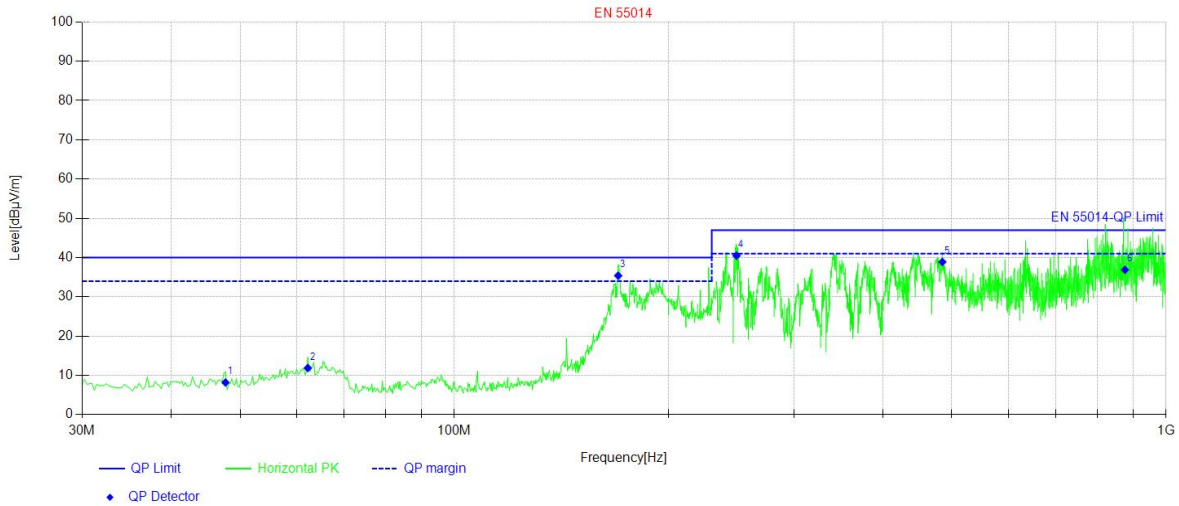

Final Data List[QP]							
NO.	Freq. [MHz]	QP Reading [dBµV/m]	Factor [dB]	QP Value [dBµV/m]	QP Limit [dBµV/m]	QP Margin [dB]	Polarity
1	47.70	25.84	-17.66	8.18	40.00	31.82	Horizontal
2	62.25	30.03	-18.14	11.89	40.00	28.11	Horizontal
3	169.92	51.69	-16.29	35.40	40.00	4.60	Horizontal
4	249.22	57.62	-17.13	40.49	47.00	6.51	Horizontal
5	484.93	50.04	-11.15	38.89	47.00	8.11	Horizontal
6	875.54	40.23	-3.34	36.89	47.00	10.11	Horizontal



7.5. HARMONICS CURRENT MEASUREMENT

7.5.1. LIMITS OF HARMONICS CURRENT MEASUREMENT

Limit for Class A equipment		Limit for Class D equipment		
Harmonics Order N	Max. permissible harmonics current A	Harmonics Order n	Max. permissible harmonics current per watt mA/W	Max. permissible harmonics current A
Odd harmonics		Odd Harmonics only		
3	2.30	3	3.4	2.30
5	1.14	5	1.9	1.14
7	0.77	7	1.0	0.77
9	0.40	9	0.5	0.40
11	0.33	11	0.35	0.33
13	0.21	13	0.30	0.21
15 ≤ n ≤ 39	0.15x(15/n)	15 ≤ n ≤ 39 (odd harmonics only)	3.85/n	0.15x(15/n)
Even harmonics				
2	1.08			
4	0.43			
6	0.30			
8 ≤ n ≤ 40	0.23x8/n			

Limit for Class C equipment ^a	
Harmonics Order n	Max. permissible harmonics current expressed as a percentage of the input current at the fundamental frequency A
2	2
3	27 ^b
5	10
7	7
9	5
11 ≤ n < ≤ 39 (odd harmonics only)	3

^a:For some Class C products, other emission limits apply (see EN IEC 61000-3-2 7.4).

^b:The limit is determined based on the assumption of modern lighting technologies having power factors of 0,90 or higher

Note: Class A, B, C and D are classified according to item 7.5.2.of this report



7.5.2. TEST PROCEDURES

The EUT was placed on the top of a wooden table 0.8 meters above the ground and operated to produce the maximum harmonic. The classification of EUT is according to section 5 of EN IEC 61000-3-2.

The EUT is classified as follows:

Class A:

Equipment not specified as belonging to Class B, C or D shall be considered as Class A equipment.

Some examples of Class A equipment are:

- balanced three-phase equipment;
- household appliances, excluding those specified as belonging to Class B, C or D;
- vacuum cleaners;
- high pressure cleaners;
- tools, excluding portable tools;
- independent phase control dimmers;
- audio equipment;
- professional luminaires for stage lighting and studios.

NOTE 1 Equipment that can be shown to have a significant effect on the supply system might be reclassified in a future edition of this document, taking into account the following factors:

- number of pieces of equipment in use;
- duration of use;
- simultaneity of use;
- power consumption;
- harmonic spectrum, including phase.

Class B:

- portable tools;
- arc welding equipment which is not professional equipment.

Class C:

- lighting equipment.

Class D:

Equipment having a specified power less than or equal to 600 W according to 6.3.2, of the following types:

- personal computers and personal computer monitors;



- television receivers;
- refrigerators and freezers having one or more variable-speed drives to control compressor motor(s).

NOTE 2 Class D limits are reserved for equipment that, by virtue of the factors listed in note 1 , can be shown to have a pronounced effect on the public electricity supply system.

The correspondent test program of test instrument to measure the current harmonics emanated from EUT is chosen. The measure time shall be not less than the time necessary for the EUT to be exercised.

7.5.3. TEST SETUP

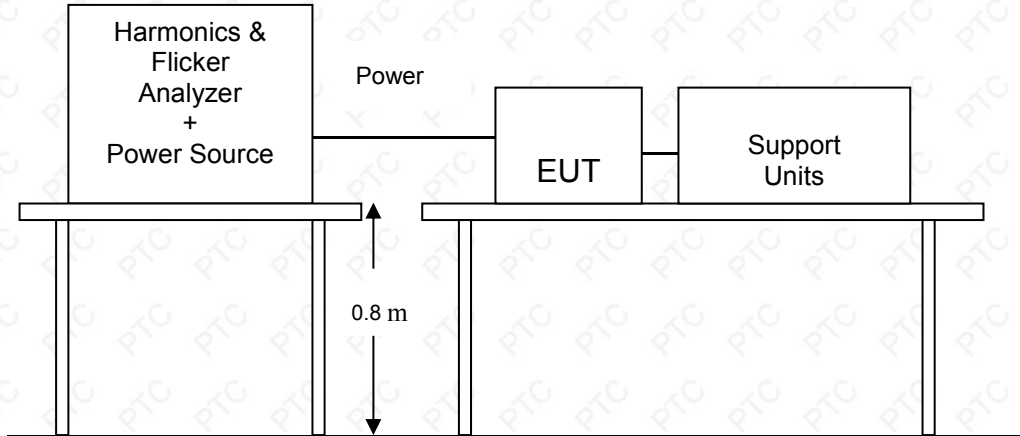

For the actual test configuration, please refer to the related item – Photographs of the Test Configuration.

7.5.4. TEST RESULT

N/A

7.6. VOLTAGE FLUCTUATION AND FLICKS MEASUREMENT

7.6.1. LIMITS OF VOLTAGE FLUCTUATION AND FLICKS MEASUREMENT

TEST ITEM	LIMIT	REMARK
P_{st}	1.0	P_{st} means short-term flicker indicator.
P_{lt}	0.65	P_{lt} means long-term flicker indicator.
T_{dt} (ms)	500	T_{dt} means maximum time that dt exceeds 3 %.
d_{max} (%)	4/6/7 %	d_{max} means maximum relative voltage change.
dc (%)	3.3 %	dc means relative steady-state voltage change

7.6.2. TEST PROCEDURE

The EUT was placed on the top of a wooden table 0.8 meters above the ground and operated to produce the most unfavorable sequence of voltage changes under lighting operating conditions. During the flick measurement, the measure time shall include that part of whole operation cycle in which the EUT produce the most unfavorable sequence of voltage changes. The observation period for short-term flicker indicator is 10 minutes and the observation period for long-term flicker indicator is 2 hours.

7.6.3. TEST SETUP

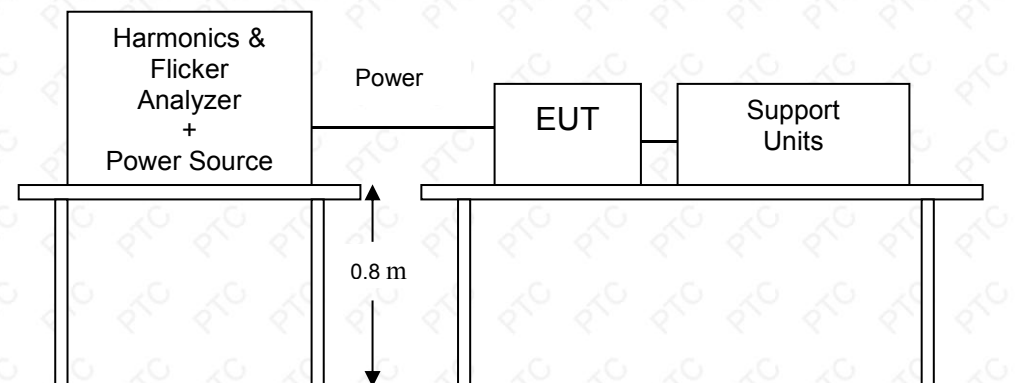

For the actual test configuration, please refer to the related item – Photographs of the Test Configuration.

7.6.4. TEST RESULT

Product	ROBOT VACUUM CLEANER	Tested by	Bruce
Model	KRV305A, KRV305B	Observation Period (T_p)	10 mins
Test Mode	Charging	Test Result	Pass
Environmental Conditions	24.3°C, 54.5 % RH, 101.1 kPa		



Please refer to the following test data:

EUT: ROBOT VACUUM CLEANER **M/N:KRV305A** **Tested by: Bruce**

Test category: All parameters (European limits) **Test Margin: 100**

Test date: 2022/12/1 **Start time: 16:56:56** **End time: 17:07:24**

Test duration (min): 10 **Data file name: F-000047.cts_data**

Comment: Charging **Customer:**

Test Result: Pass **Status: Test Completed**

Pst_i and limit line

European Limits

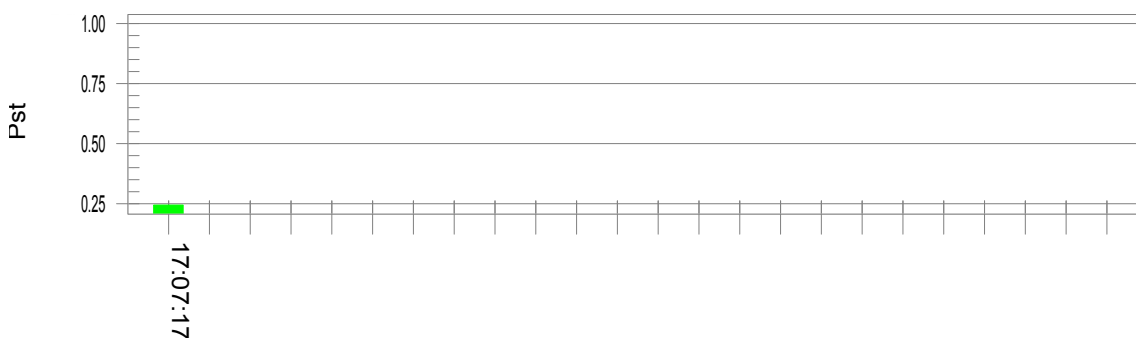

Plt and limit line



Parameter values recorded during the test:

Vrms at the end of test (Volt):	228.87		
Highest dt (%):		Test limit (%):	
T-max (mS):	0	Test limit (mS):	500.0 Pass
Highest dc (%):	0.00	Test limit (%):	3.30 Pass
Highest dmax (%):	0.00	Test limit (%):	4.00 Pass
Highest Pst (10 min. period):	0.244	Test limit:	1.000 Pass
Highest Plt (2 hr. period):	0.107	Test limit:	0.650 Pass



EUT: ROBOT VACUUM CLEANER

M/N:KRV305B

Tested by: Bruce

Test category: All parameters (European limits)

Test Margin: 100

Test date: 2022/12/2

Start time: 10:13:42

End time: 10:24:09

Test duration (min): 10

Data file name: F-000056.cts_data

Comment: Charging

Customer:

Test Result: Pass

Status: Test Completed

Pst_i and limit line

European Limits

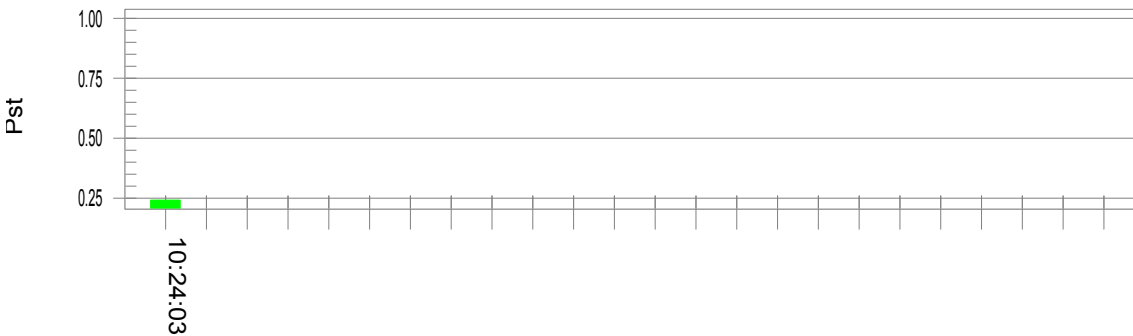

Plt and limit line



Parameter values recorded during the test:

Vrms at the end of test (Volt): 228.93

Highest dt (%):

Test limit (%):

T-max (mS): 0

Test limit (mS): 500.0 Pass

Highest dc (%): 0.00

Test limit (%): 3.30 Pass

Highest dmax (%): 0.00

Test limit (%): 4.00 Pass

Highest Pst (10 min. period): 0.242

Test limit: 1.000 Pass

Highest Plt (2 hr. period): 0.106

Test limit: 0.650 Pass



8. IMMUNITY TEST

8.1. GENERAL DESCRIPTION

Product Standard	EN IEC 55014-2	
	Test Type	Minimum Requirement
Basic Standard, Specification, and Performance Criterion required	IEC 61000-4-2	Electrostatic Discharge – ESD: ±8 kV air discharge, ±4 kV Contact discharge, Performance Criterion B
	IEC 61000-4-3	Radio-Frequency Electromagnetic Field Susceptibility Test – RS: 80 MHz to 1 GHz, 3 V/m, 80 % AM(1 kHz), Performance Criterion A
	IEC 61000-4-4	Electrical Fast Transient/Burst - EFT, Power line: ±1kV, Signal line: ±0.5kV, Performance Criterion B
	IEC 61000-4-5	Surge Immunity Test: 1.2/50 μs Open Circuit Voltage, 8 /20 μs Short Circuit Current, Power Port ~ Line to line: ±1 kV, Line to ground: ±2 kV Signal and Control Port : ±0.5 kV Performance Criterion B
	IEC 61000-4-6	Conducted Radio Frequency Disturbances Test –CS: 0.15 ~ 80 MHz, 3 Vrms, 80 % AM, 1 kHz, Performance Criterion A
	IEC 61000-4-11	Voltage Dips and Interruptions: 50/60Hz i) 0 % reduction for 0.5/0.5 period, Performance Criterion C ii) 40 % reduction for 10/12 period, Performance Criterion C iii) 70 % reduction for 25/30 period Performance Criterion C



8.2. GENERAL PERFORMANCE CRITERIA DESCRIPTION

Criteria A:	The apparatus shell continues to operate as intended without operator intervention. No degradation of performance or loss of function is allowed below a performance level specified by the manufacturer, when the apparatus is used as intended. The performance level may be replaced by a permissible loss of performance. If the manufacturer does not specify the minimum performance level or the permissible performance loss, then either of these may be derived from the product description and documentation, and by what the user may reasonably expect from the equipment if used as intended.
Criteria B:	<p>After test, the apparatus shell continues to operate as intended without operator intervention. No degradation of performance or loss of function is allowed, after the application of the phenomenon below a performance level specified by the manufacturer, when the apparatus is used as intended. The performance level may be replaced by a permissible loss of performance.</p> <p>During the test, degradation of performance is however allowed. However, no change of operating state if stored data is allowed to persist after the test. If the manufacturer does not specify the minimum performance level or the permissible performance loss, then either of these may be derived from the product description and documentation, and by what the user may reasonably expect from the equipment if used as intended.</p>
Criteria C:	<p>Temporary loss of function is allowed, provided the functions is self-recoverable or can be restored by the operation of controls by the user in accordance with the manufacturer instructions.</p> <p>Functions, and/or information stored in non-volatile memory, or protected by a battery backup, shall not be lost.</p>



8.3. ELECTROSTATIC DISCHARGE (ESD)

8.3.1. TEST SPECIFICATION

Basic Standard:	IEC 61000-4-2
Discharge Impedance:	330 Ω
Charging/Working Capacity:	150 pF
Discharge Voltage:	Air Discharge: ± 8 kV (Direct) Contact Discharge: ± 4 kV (Direct/Indirect)
Polarity:	Positive & Negative
Number of Discharge:	10 times at each test point
Discharge Mode:	1 time/s
Performance Criterion:	B

8.3.2. TEST PROCEDURE

The discharges shall be applied in two ways:

- a) Contact discharges to the conductive surfaces and coupling planes:
Twenty dischargers (10 with positive and 10 with negative polarity) shall be applied on each accessible metallic part of the enclosure, terminals are excluded. In case of a non-conductive enclosure, dischargers shall be applied on the horizontal or vertical coupling planes. Test shall be performed at a maximum repetition rate of one discharge per second.
- b) Air discharges at slots and apertures and insulating surfaces:
On those parts of the EUT where it is not possible to perform contact discharge testing, the equipment should be investigated to identify user accessible points where breakdown may occur. Such points are tested using the air discharge method. This investigation should be restricted to those area normally handled by the user. A minimum of 10 single air discharges shall be applied to the selected test point for each such area.

The basic test procedure was in accordance with IEC 61000-4-2:

- a) The EUT was located 0.1 m minimum from all side of the HCP (dimensions 1.6 m x 0.8 m).
- b) The support units were located another table 30 cm away from the EUT, but direct support unit was/were located at same location as EUT on the HCP and keep at a distance of 10cm with EUT.

- c) The time interval between two successive single discharges was at least 1 second.
- d) Contact discharges were applied to the non-insulating coating, with the pointed tip of the generator penetrating the coating and contacting the conducting substrate.
- e) Air discharges were applied with the round discharge tip of the discharge electrode approaching the EUT as fast as possible (without causing mechanical damage) to touch the EUT. After each discharge, the ESD generator was removed from the EUT and re-triggered for a new single discharge. The test was repeated until all discharges were complete.
- f) At least ten single discharges (in the most sensitive polarity) were applied at the front edge of each HCP opposite the center point of each unit of the EUT and 0.1 meters from the front of the EUT. The long axis of the discharge electrode was in the plane of the HCP and perpendicular to its front edge during the discharge.
- g) At least ten single discharges (in the most sensitive polarity) were applied to the center of one vertical edge of the Vertical Coupling Plane (VCP) in sufficiently different positions that the four faces of the EUT were completely illuminated. The VCP (dimensions 0.5 m x 0.5 m) was placed vertically to and 0.1 meters from the EUT.

8.3.3. TEST SETUP

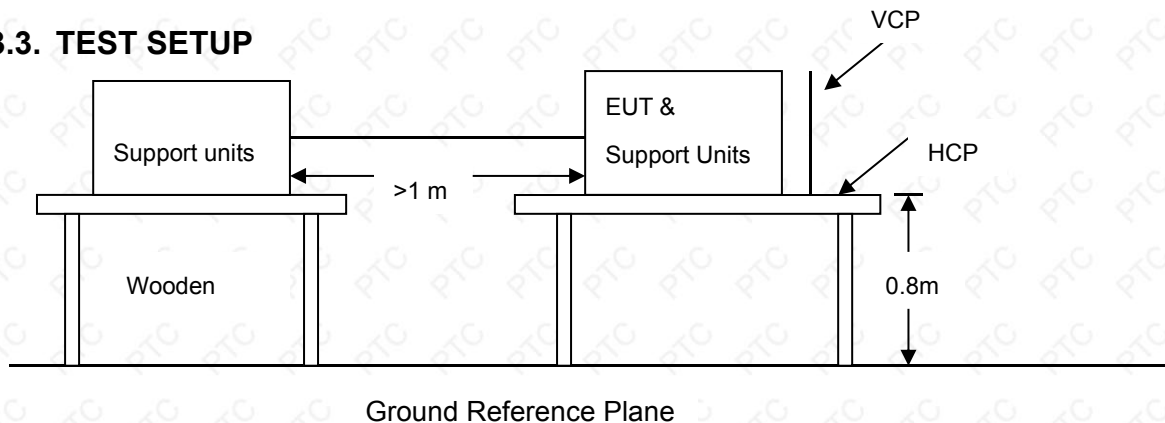

For the actual test configuration, please refer to the related item – Photographs of the Test Configuration.

Note:

1) TABLE-TOP EQUIPMENT

The configuration consisted of a wooden table 0.8 meters high standing on the ground reference plane (GRP). The GRP consisted of a sheet of aluminum at least 0.25 mm thick, and 2.5 meters square connected to the protective grounding system. A horizontal coupling plane (HCP) (1.6 m x 0.8 m) was placed on the table and attached to the GRP by means of a cable with 940k total impedance. The



equipment under test, was installed in a representative system as described in section 7 of IEC 61000-4-2, and its cables were placed on the HCP and isolated by an insulating support of 0.5 mm thickness. A distance of 1-meter minimum was provided between the EUT and the walls of the laboratory and any other metallic structure.

2) FLOOR-STANDING EQUIPMENT

The equipment under test was installed in a representative system as described in section 7 of IEC 61000-4-2, and its cables were isolated from the ground reference plane by an insulating support of 0.1 meter thickness. The GRP consisted of a sheet of aluminum that is at least 0.25 mm thick, and 2.5 meters square connected to the protective grounding system and extended at least 0.5 meters from the EUT on all sides.

8.3.4. TEST RESULT

Product	ROBOT VACUUM CLEANER	Environmental Conditions	24.3°C, 52 % RH, 101.2 kPa
Model	KRV305A,KRV305B	Tested By	LiRong
Test mode	Charging/Working	Test Result	Pass

Air Discharge					
Test Points	Test Levels	Results			
	± 8 kV	Pass	Fail	Observation	Performance Criterion
GAP	<input checked="" type="checkbox"/>	<input checked="" type="checkbox"/>	<input type="checkbox"/>	Note <input checked="" type="checkbox"/> A <input type="checkbox"/> B <input type="checkbox"/> C	B
Hull	<input checked="" type="checkbox"/>	<input checked="" type="checkbox"/>	<input type="checkbox"/>	Note <input checked="" type="checkbox"/> A <input type="checkbox"/> B <input type="checkbox"/> C	B

Contact Discharge					
Test Points	Test Levels	Results			
	± 4 kV	Pass	Fail	Observation	Performance Criterion
HCP	<input checked="" type="checkbox"/>	<input checked="" type="checkbox"/>	<input type="checkbox"/>	Note <input checked="" type="checkbox"/> A <input type="checkbox"/> B <input type="checkbox"/> C	B
VCP	<input checked="" type="checkbox"/>	<input checked="" type="checkbox"/>	<input type="checkbox"/>	Note <input checked="" type="checkbox"/> A <input type="checkbox"/> B <input type="checkbox"/> C	B

- Note: A) There was no change compared with initial operation during the test.
 B) During the test, degradation of performance is allowed. However, no change of operating state or stored data is allowed to persist after the test. If the minimum performance level (or the permissible performance loss) is not specified by the manufacturer, then either of these may be derived from the product description and documentation, and by what the user may reasonably expect from the EUT if used as intended.
 C) During and after testing, a temporary loss of function is allowed, provided the function is self-recoverable, or can be restored by the operation of the controls or cycling of the power to the EUT by the user in accordance with the manufacturer's instructions.



8.4. RADIATED RADIO-FREQUENCY, ELECTROMAGNETIC FIELD (RS)

8.4.1. TEST SPECIFICATION

Basic Standard:	IEC 61000-4-3
Frequency Range:	80 MHz ~ 1000 MHz
Field Strength:	3 V/m
Modulation:	1 kHz Sine Wave, 80 %, AM Modulation
Frequency Step:	1 % of preceding frequency value
Polarity of Antenna:	Horizontal and Vertical
Test Distance:	3 m
Antenna Height:	1.5 m
Performance Criterion:	A

8.4.2. TEST PROCEDURE

The test procedure was in accordance with IEC 61000-4-3

- The testing was performed in a fully anechoic chamber. The transmit antenna was located at a distance of 3 meters from the EUT.
- The frequency range is swept from 80 MHz to 1000 MHz, with the signal 80% amplitude modulated with a 1 kHz sine-wave. The rate of sweep did not exceed 1.5×10^{-3} decade/s, where the frequency range is swept incrementally, the step size was 1 % of preceding frequency value.
- The dwell time at each frequency shall be not less than the time necessary for the EUT to be able to respond.
- The test was performed with the EUT exposed to both vertically and horizontally polarized fields on each of the four sides.

8.4.3. TEST SETUP

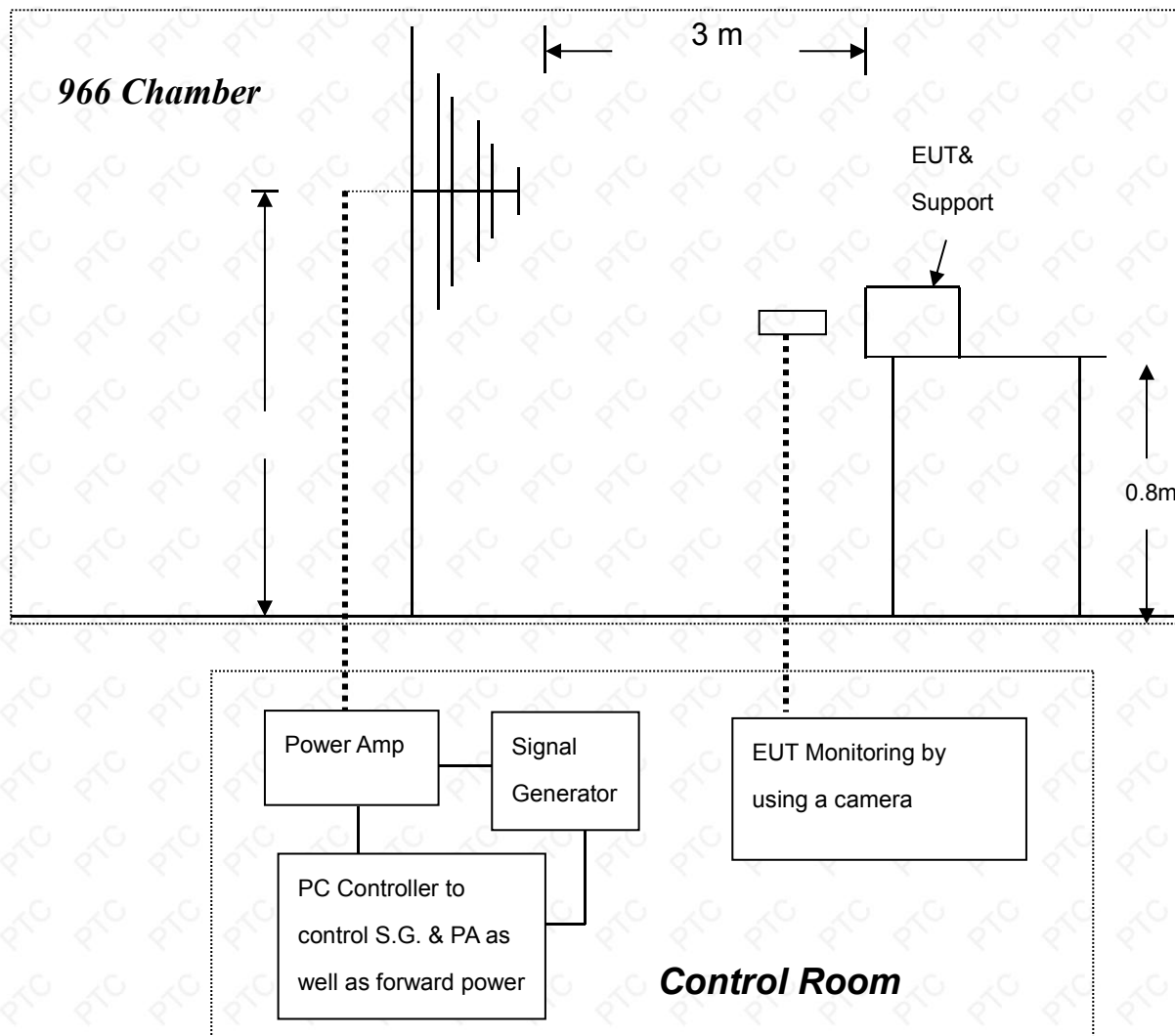

For the actual test configuration, please refer to the related item – Photographs of the Test Configuration.

Note:

TABLETOP EQUIPMENT

The EUT installed in a representative system as described in section 7 of IEC 61000-4-3 was placed on a non-conductive table 0.8 meters in height. The system under test was connected to the power and signal wire according to relevant installation instructions.

FLOOR STANDING EQUIPMENT

The EUT installed in a representative system as described in section 7 of IEC 61000-4-3 was placed on a non-conductive wood support 0.1 meters in height. The system under test was connected to the power and signal wire according to relevant installation instructions.



8.4.4. TEST RESULT

Product	ROBOT VACUUM CLEANER	Environmental Conditions	24.1°C, 53 % RH, 101.1 kPa
Model	KRV305A,KRV305B	Tested By	LiRong
Test mode	Charging/Working	Test Result	Pass

Frequency (MHz)	Polarity	Position	Field Strength (V/m)	Observation	Performance Criterion
80 ~ 1000	V&H	Front	3	Note <input checked="" type="checkbox"/> A <input type="checkbox"/> B <input type="checkbox"/> C	A
80 ~ 1000	V&H	Rear	3	Note <input checked="" type="checkbox"/> A <input type="checkbox"/> B <input type="checkbox"/> C	A
80 ~ 1000	V&H	Left	3	Note <input checked="" type="checkbox"/> A <input type="checkbox"/> B <input type="checkbox"/> C	A
80 ~ 1000	V&H	Right	3	Note <input checked="" type="checkbox"/> A <input type="checkbox"/> B <input type="checkbox"/> C	A

Note: A) There was no change compared with initial operation during the test.

B) During the test, degradation of performance is allowed. However, no change of operating state or stored data is allowed to persist after the test. If the minimum performance level (or the permissible performance loss) is not specified by the manufacturer, then either of these may be derived from the product description and documentation, and by what the user may reasonably expect from the EUT if used as intended.

C) During and after testing, a temporary loss of function is allowed, provided the function is self-recoverable, or can be restored by the operation of the controls or cycling of the power to the EUT by the user in accordance with the manufacturer's instructions.



8.5. ELECTRICAL FAST TRANSIENT (EFT)

8.5.1. TEST SPECIFICATION

Basic Standard:	IEC 61000-4-4
Test Voltage:	Power Line: ± 1 kV Signal/Control Line: ± 0.5 kV
Polarity:	Positive & Negative
Impulse Frequency:	5 kHz
Impulse Wave-shape:	5/50 ns
Burst Duration:	15 ms
Burst Period:	300 ms
Test Duration:	2 mins
Performance Criterion:	B

8.5.2. TEST PROCEDURE

EUT is placed on a 0.1 m tall wooden table.

EUT operate at normal mode, the transient/burst was 5/50 ns in accordance with IEC 61000-4-4, both positive and negative polarity burst waveform were applied.

The duration time of each test line was 2 minutes.

8.5.3. TEST SETUP

The EUT installed in a representative system as described in section 7 of IEC 61000-4-4.

For the actual test configuration, please refer to the related item – photographs of the test configuration.



8.5.4. TEST RESULT

Product	ROBOT VACUUM CLEANER	Environmental Conditions	24.3°C, 52 % RH, 101.2 kPa
Model	KRV305A,KRV305B	Tested By	LiRong
Test mode	Charging	Test Result	Pass

Test Point	Polarity	Test Level (kV)	Observation	Performance Criterion
L	+/-	1	Note <input checked="" type="checkbox"/> A <input type="checkbox"/> B <input type="checkbox"/> C	B
N	+/-	1	Note <input checked="" type="checkbox"/> A <input type="checkbox"/> B <input type="checkbox"/> C	B
L – N	+/-	1	Note <input checked="" type="checkbox"/> A <input type="checkbox"/> B <input type="checkbox"/> C	B
RJ45 UTP cable	--	--	--	--

Note: A) There was no change compared with initial operation during the test.

B) During the test, degradation of performance is allowed. However, no change of operating state or stored data is allowed to persist after the test. If the minimum performance level (or the permissible performance loss) is not specified by the manufacturer, then either of these may be derived from the product description and documentation, and by what the user may reasonably expect from the EUT if used as intended.

C) During and after testing, a temporary loss of function is allowed, provided the function is self-recoverable, or can be restored by the operation of the controls or cycling of the power to the EUT by the user in accordance with the manufacturer's instructions.



8.6. SURGE IMMUNITY TEST

8.6.1. TEST SPECIFICATION

Basic Standard:	IEC 61000-4-5
Wave-Shape:	Combination Wave 1.2/50 μ s Open Circuit Voltage 8/20 μ s Short Circuit Current
Test Voltage:	Power Port ~ Line to line: ± 1 kV, Line to ground: ± 2 kV
Surge Input/Output:	Power Line: L-N / L-PE / N-PE
Generator Source Impedance:	2 Ω between networks 12 Ω between network and ground
Polarity:	Positive/Negative
Phase Angle:	90°(positive polarity pulses) / 270°(negative polarity pulses)
Pulse Repetition Rate:	1 time / min
Number of Tests:	5 positive polarity pulses at the 90° phase angle, and 5 negative polarity pulses at 270° phase angle
Performance Criterion:	B

8.6.2. TEST PROCEDURE

EUT is placed on a 0.1 m (table type equipment) / 0.8 m (floor type equipment) tall wooden table.

EUT operate at normal mode, two types of combination wave generator (1.2/50 us open-circuit voltage and 8/20 us short-circuit current) are applied to the EUT power supply terminals via the capacitive coupling network.

The power cord between the EUT and the coupling/decoupling network shall not exceed 2 m in length.

8.6.3. TEST SETUP

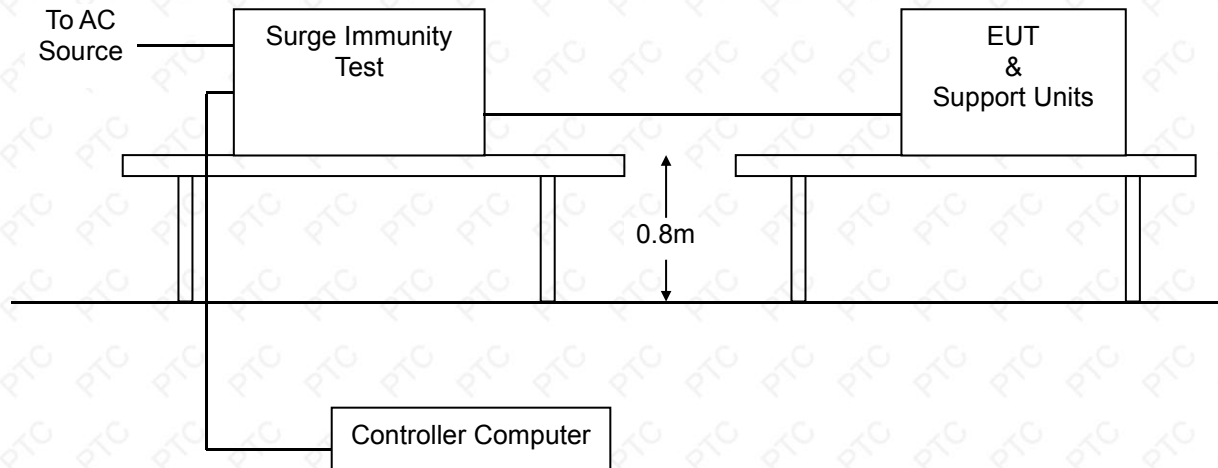

For the actual test configuration, please refer to the related item – Photographs of the Test Configuration.

8.6.4. TEST RESULT

Product	ROBOT VACUUM CLEANER	Environmental Conditions	24.3°C, 52 % RH, 101.2 kPa
Model	KRV305A,KRV305B	Tested By	LiRong
Test mode	Charging	Test Result	Pass

Test Point	Polarity	Test Level (kV)	Observation	Performance Criterion
L - N	+/-	1	Note <input checked="" type="checkbox"/> A <input type="checkbox"/> B <input type="checkbox"/> C	B

Note: A) There was no change compared with initial operation during the test.

B) During the test, degradation of performance is allowed. However, no change of operating state or stored data is allowed to persist after the test. If the minimum performance level (or the permissible performance loss) is not specified by the manufacturer, then either of these may be derived from the product description and documentation, and by what the user may reasonably expect from the EUT if used as intended.

C) During and after testing, a temporary loss of function is allowed, provided the function is self-recoverable, or can be restored by the operation of the controls or cycling of the power to the EUT by the user in accordance with the manufacturer's instructions.

8.7. CONDUCTED RADIO FREQUENCY DISTURBANCES (CS)

8.7.1. TEST SPECIFICATION

Basic Standard:	IEC 61000-4-6
Frequency Range:	0.15 MHz ~230 MHz
Field Strength:	3 V
Modulation:	1 kHz Sine Wave, 80 %, AM Modulation
Frequency Step:	1 % of preceding frequency value
Coupled cable:	Power Mains, Shielded
Coupling device:	CDN-M3/2 (3 wires/2 wires)
Performance Criterion:	A

8.7.2. TEST PROCEDURE

The EUT shall be tested within its intended operating and climatic conditions.

The test shall be performed with the test generator connected to each of the coupling and decoupling devices in turn, while the other non-excited RF input ports of the coupling devices are terminated by a 50 Ω load resistor.

The frequency range was swept from 150 kHz to 230 MHz, using the signal level established during the setting process and with a disturbance signal of 80 % amplitude. The signal was modulated with a 1 kHz sine wave, pausing to adjust the RF signal level or the switch coupling devices as necessary. The sweep rate was 1.5×10^{-3} decades/s. Where the frequency range is swept incrementally, the step size was 1 % of preceding frequency value the dwell time of the amplitude modulated carrier at each frequency was 0.5 s.

8.7.3. TEST SETUP

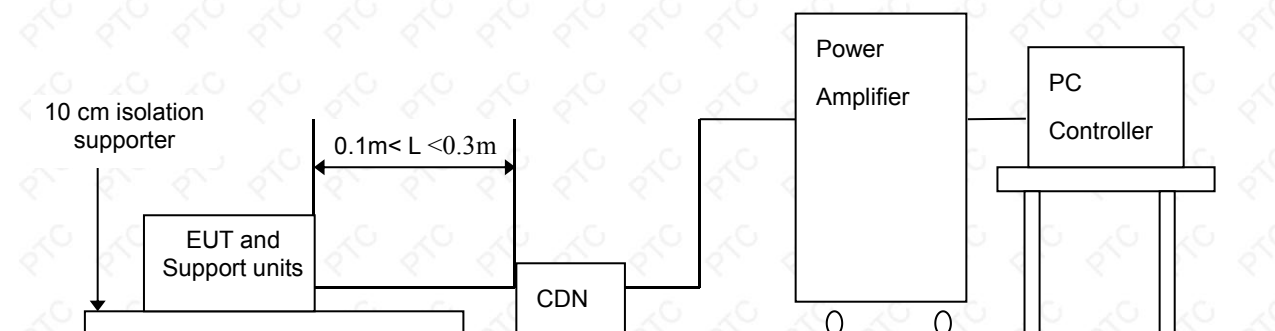

For the actual test configuration, please refer to the related item – Photographs of the Test Configuration

Note: 1) The EUT is setup 0.1 m above Ground Reference Plane

2) All relevant cables shall be provided with the appropriate coupling and decoupling devices at a distance between 0.1 meters and 0.3 meters from the projected geometry of the EUT on the ground reference plane.



8.7.4. TEST RESULT

Product	ROBOT VACUUM CLEANER	Environmental Conditions	23.9°C, 50 % RH, 100.6 kPa
Model	KRV305A,KRV305B	Tested By	LiRong
Test mode	Charging	Test Result	Pass

Frequency (MHz)	Field Strength (Vrms)	Injected Position	Injection Method	Observation	Performance Criterion
0.15 ~ 80	3	AC Mains	CDN-M2/M3	Note <input checked="" type="checkbox"/> A <input type="checkbox"/> B <input type="checkbox"/> C	A

Note: A) There was no change compared with initial operation during the test.

B) During the test, degradation of performance is allowed. However, no change of operating state or stored data is allowed to persist after the test. If the minimum performance level (or the permissible performance loss) is not specified by the manufacturer, then either of these may be derived from the product description and documentation, and by what the user may reasonably expect from the EUT if used as intended.

C) During and after testing, a temporary loss of function is allowed, provided the function is self-recoverable, or can be restored by the operation of the controls or cycling of the power to the EUT by the user in accordance with the manufacturer's instructions.

8.8. VOLTAGE DIP & VOLTAGE INTERRUPTIONS

8.8.1. TEST SPECIFICATION

Basic Standard:	IEC 61000-4-11
Test Duration Time:	3 test events in sequence
Interval Between Event:	10 seconds
Phase Angle:	0°
Test Cycle:	3 times
Performance Criterion:	C

8.8.2. TEST PROCEDURE

The EUT and support units were located on a wooden table, 0.8 m away from ground floor.

Setting the parameter of tests and then perform the test software of test simulator.

Changes to the voltage level shall occur at 0 degree crossing point in the a.c. voltage waveform.

Record the test result in test record form.

8.8.3. TEST SETUP

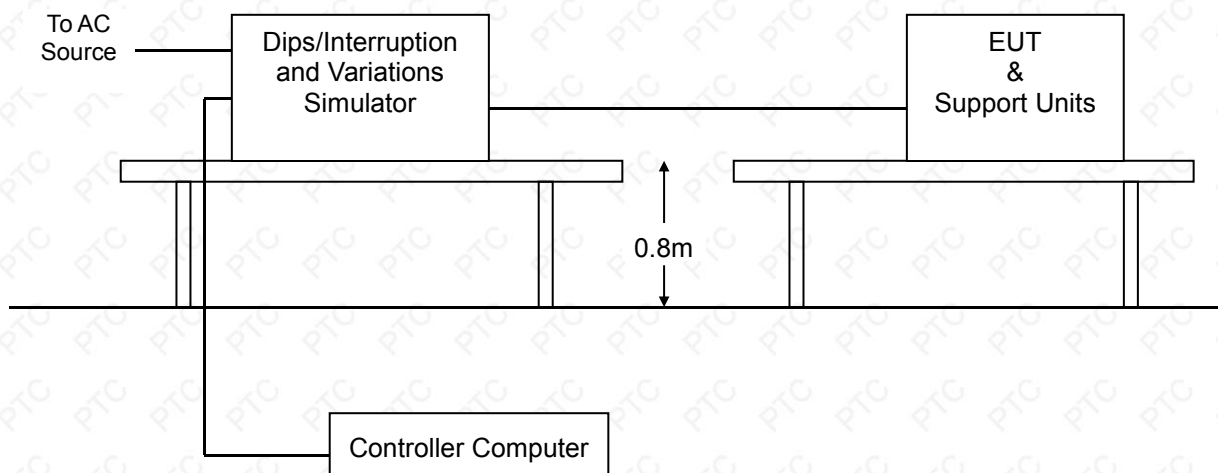

For the actual test configuration, please refer to the related item – Photographs of the Test Configuration.



8.8.4. TEST RESULT

Product	ROBOT VACUUM CLEANER	Environmental Conditions	24.3°C, 54 % RH, 101.2 kPa
Model	KRV305A,KRV305B	Tested By	LiRong
Test mode	Charging	Test Result	Pass

Test Power: 110/230 Vac, 50/60 Hz			
Voltage (% Reduction)	Duration (Period)	Observation	Performance Criterion
0	0.5/0.5	Note <input checked="" type="checkbox"/> A <input type="checkbox"/> B <input type="checkbox"/> C	C
40	10/12	Note <input checked="" type="checkbox"/> A <input type="checkbox"/> B <input type="checkbox"/> C	C
70	25/30	Note <input checked="" type="checkbox"/> A <input type="checkbox"/> B <input type="checkbox"/> C	C

- Note: A) There was no change compared with initial operation during the test.
 B) During the test, degradation of performance is allowed. However, no change of operating state or stored data is allowed to persist after the test. If the minimum performance level (or the permissible performance loss) is not specified by the manufacturer, then either of these may be derived from the product description and documentation, and by what the user may reasonably expect from the EUT if used as intended.
 C) During and after testing, a temporary loss of function is allowed, provided the function is self-recoverable, or can be restored by the operation of the controls or cycling of the power to the EUT by the user in accordance with the manufacturer's instructions.

9. PHOTOGRAPHS OF THE TEST CONFIGURATION CONDUCTED EMISSION TEST



RADIATED EMISSION TEST

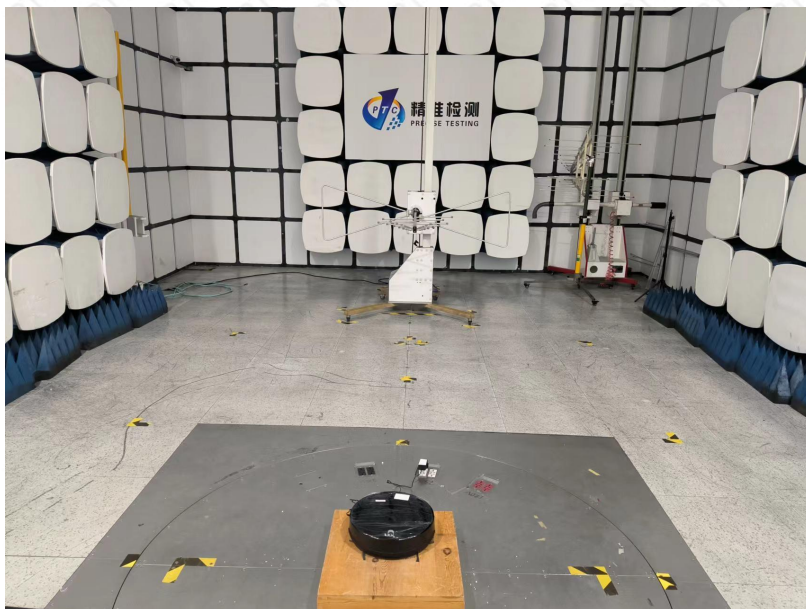



HARMONICS & FLICKER TEST



ESD TEST

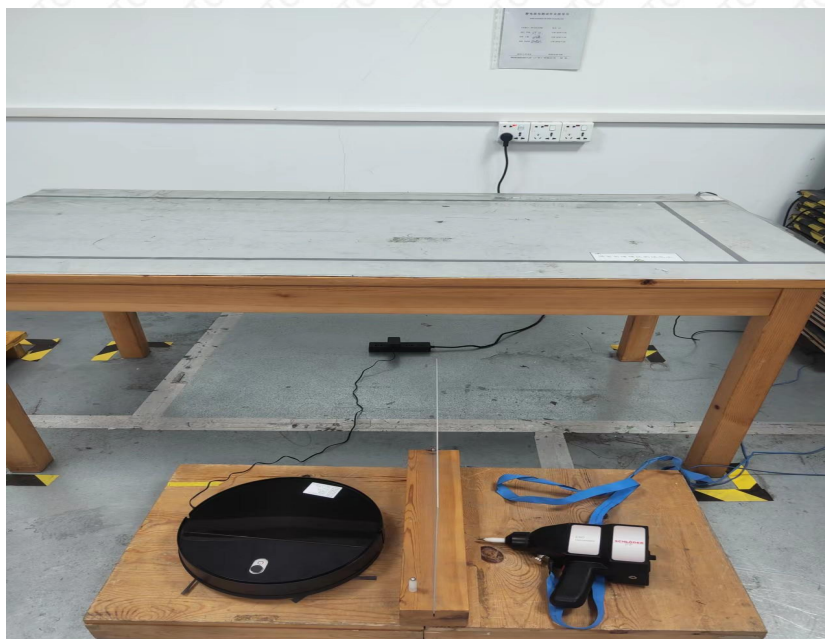

EFT TEST



SURGE TEST

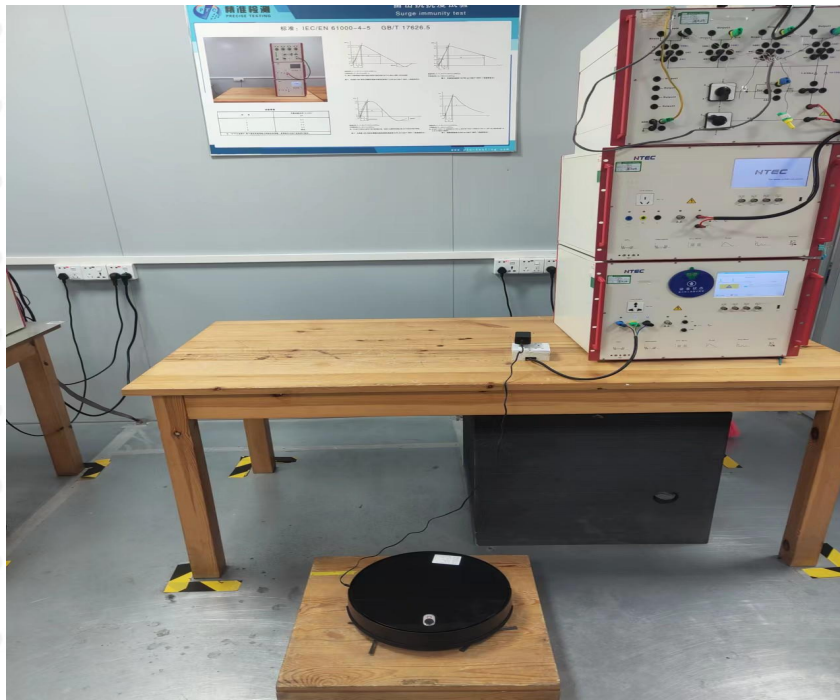

CS TEST

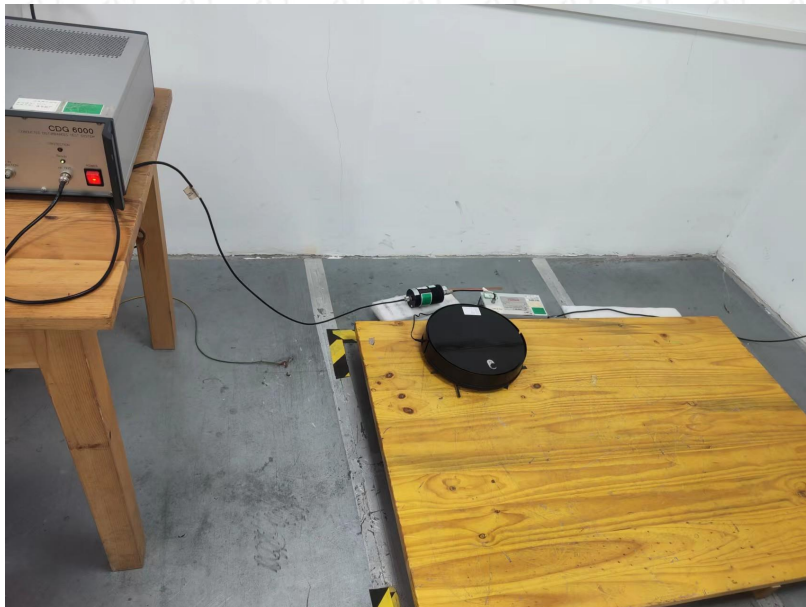

DIPS TEST

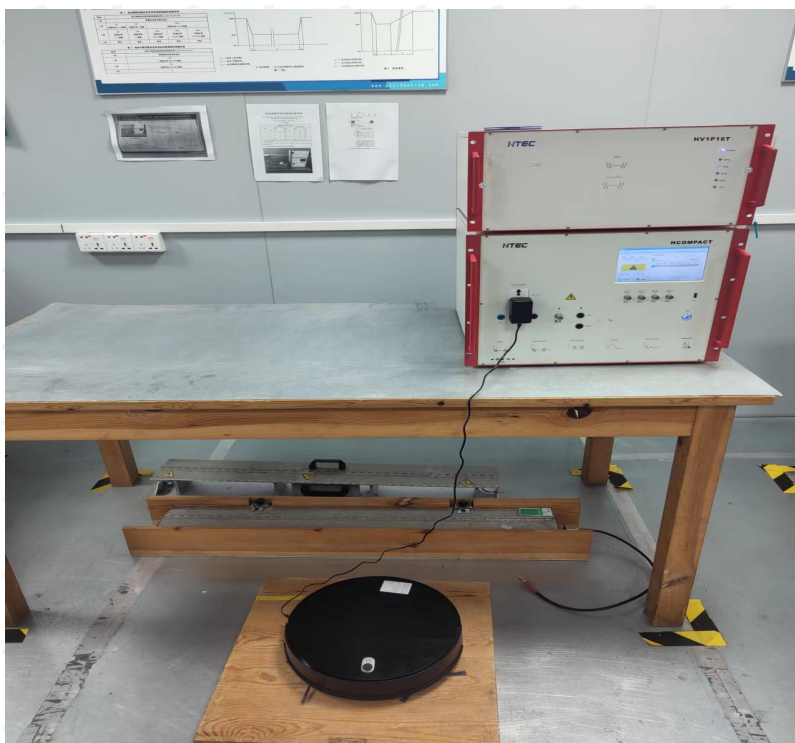

10. PHOTOGRAPHS OF EUT



KRV305A



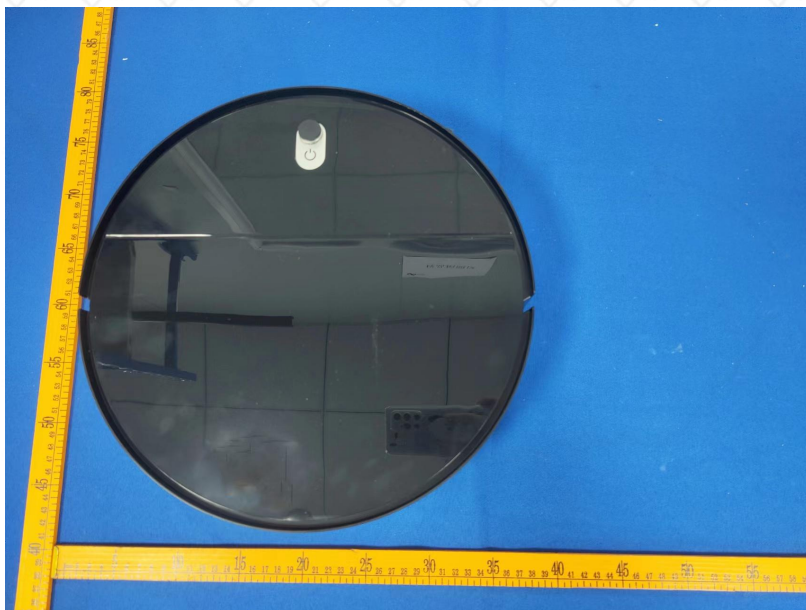

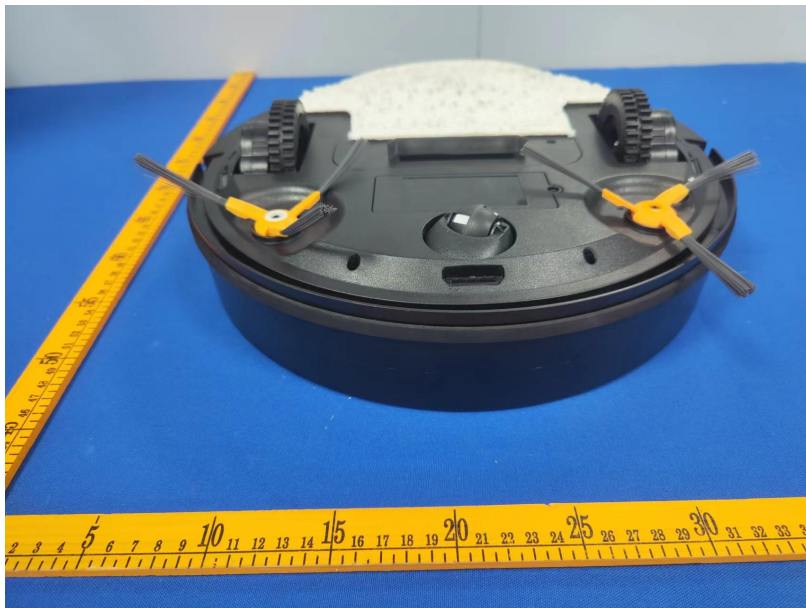
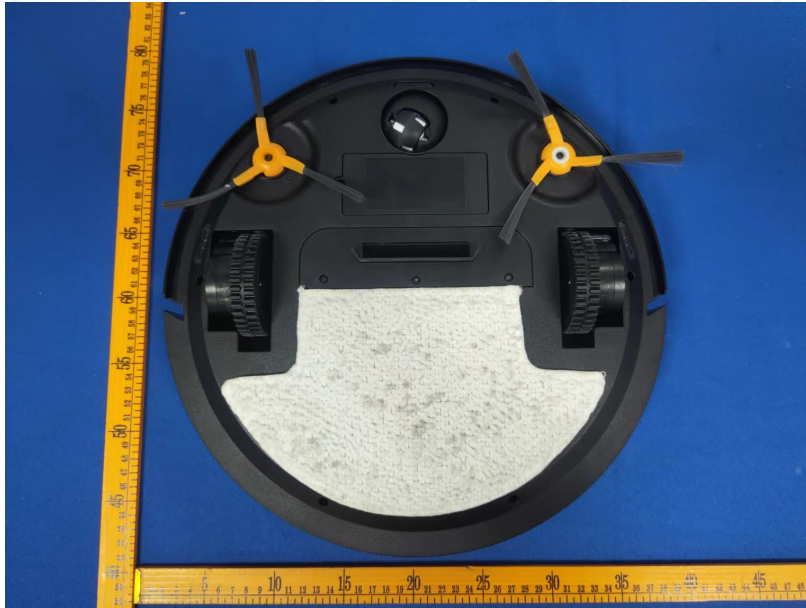

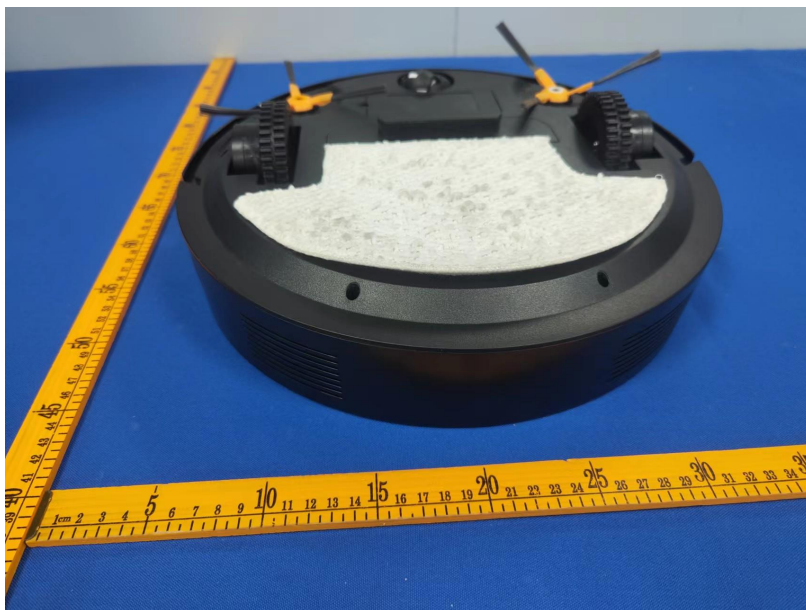





KRV305B

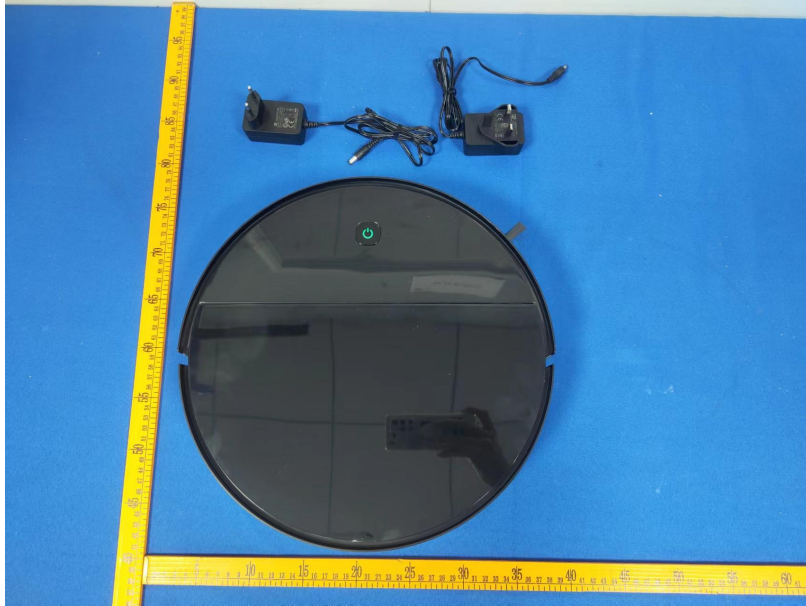

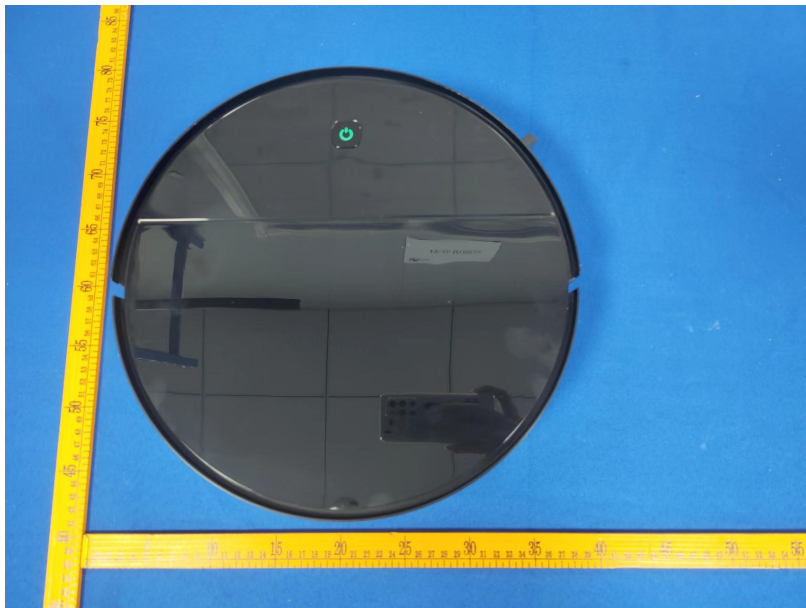

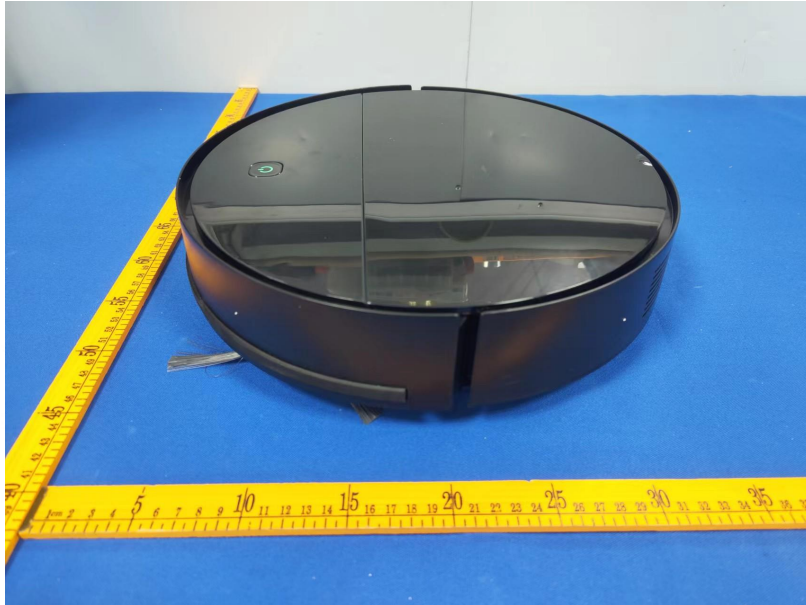



— End of report —