

CUSTOMER NAME



TEST REPORT

SCOPE OF WORK

STANDBY AND OFF MODE ELECTRIC POWER CONSUMPTION- HANDLE GARMENT STEAMER [REFER TO PAGE 2]

REPORT NUMBER

211200024SHA-001

ISSUE DATE

7-December-2021

PAGES

16

DOCUMENT CONTROL NUMBER

TTRF No. HA EU-ERP ED03 (07-August-2017)

© 2021 INTERTEK



TEST REPORT

REQUIREMENTS FOR STAND-BY AND OFF MODE LOSSES ACCORDING TO THE EC REGULATION (EC) NO 1275/2008, AMENDED BY (EU) 801/2013 AND BY (EU) 2019/2021

Part of underlying framework Directive 2009/125/EC, of the European Parliament and of the Council with regard to ecodesign requirements for standby and off mode electric power consumption of electrical and electronic household and office equipment.

Applicant, identification of the test sample

Applicant	
Address	
Manufacturer	
Address	
Type of appliance	Handle garment steamer
Intended use	For maintenance of clothes
Brand name	--
Type	DF-019, DF-019A, DF-019C
Intertek Report No.	211200024SHA-001
Serial number	N/A (Engineering sample)
Receipt condition	Intact
Sample receipt date	1-December-2021
Test date	7-December-2021
Electrical data	220-240V~, 50-60Hz, Class I DF-019, DF-019A: 1100W DF-019C: 1500W

Remark: N/A.

This report is for the exclusive use of Intertek's Client and is provided pursuant to the agreement between Intertek and its Client. Intertek's responsibility and liability are limited to the terms and conditions of the agreement. Intertek assumes no liability to any party, other than to the Client in accordance with the agreement, for any loss, expense or damage occasioned by the use of this report. Only the Client is authorized to permit copying or distribution of this report and then only in its entirety. Any use of the Intertek name or one of its marks for the sale or advertisement of the tested material, product or service must first be approved in writing by Intertek. The observations and test results in this report are relevant only to the sample tested. This report by itself does not imply that the material, product, or service is or has ever been under an Intertek certification program. The test report only allows to be revised within the retention period unless further standard or the requirement was noticed

TEST REPORT**Summary of test result:**

The power consumption of DF-019A in off mode is 0.00 W. (Power consumption of equipment in any off -mode condition shall not exceed 0.50W)

(DF-019A and DF-019C are same circuit, except rating)

The appliances of the model DF-019 do not incorporate with the standby/of mode.

The appliances of the model DF-019 incorporate with the "active mode": Plug in; red neon lamp on.

This report replaces the report 180900826SHA-001.

The result is in compliance with the 2nd stage requirements of the (EC) NO 1275/2008, amended by (EU) 801/2013 and by (EU) 2019/2021.

TEST REPORT

Standard and environmental condition

Test laboratory	Intertek Testing Services Shanghai Limited.	
Address	Bl No.86, 1198 Qinzhou Road(North), Shanghai, China 200233	
Standard applied	EN 50564: 2011 + (EC) NO 1275/2008 and (EU) NO 801/2013 and (EU) 2019/2021	
Tested at	230VAC / 50 Hz	
Ambient temp.	23°C	
Air speed close to the EUT (≤0.5 m/s)	0.25 m/s	
Crest factor of test voltage (1,34 - 1,49)	1.42	
VTHD(%)	2%	
Measuring device	Yokogawa WT310 Power Meter	Inventory number: EC5405
Set-up and circuits used for electrical testing	See Page 15 Testing circuit	

Measurement conditions

Operating condition	Off-mode
Method used	Sampling method (clause 5.3.2 EN 50564: 2011 + (EC) NO 1275/2008 and (EU) NO 801/2013 and (EU) 2019/2021)
Comments	The appliance is connected to the mains power source and is not providing any function. The timer or switch of the appliance was set at "off" position.

Operating condition	Standby
Method used	Sampling method (clause 5.3.2 EN 50564: 2011 + (EC) NO 1275/2008 and (EU) NO 801/2013 and (EU) 2019/2021)
Comments	The appliance is connected to the mains power source and with or without information display.

Measurements uncertainty:

Measurements of power of 0,50 W or greater are made with an uncertainty of less than or equal to 2 % at the 95 % confidence level. Measurements of power of less than 0,50 W are made with an uncertainty of less than or equal to 0,01 W at the 95 % confidence level.

TEST REPORT

Test and verification results

Annex II of EC NO 1275/2008			
Clause	Ecodesign requirements, 1st stage (Apply as from January 7 th , 2010)	Result - Remark	Verdict
1a)	Power consumption in 'off mode': Power consumption of equipment in any off-mode condition shall not exceed 1,00 W		N/A
1b)	Power consumption in 'standby mode(s)': The power consumption of equipment in any condition providing only a reactivation function, or providing only a reactivation function and a mere indication of enabled reactivation function, shall not exceed 1,00 W		N/A
1b)	Power consumption in 'standby mode(s)': The power consumption of equipment in any condition providing only information or status display, or providing only a combination of reactivation function and information or status display, shall not exceed 2,00 W		N/A
1c)	Availability of off mode and/or standby mode Equipment shall, except where this is inappropriate for the intended use, provide off mode and/or standby mode, and/or another condition which does not exceed the applicable power consumption requirements for off mode and/or standby mode when the equipment is connected to the mains power source. - Characteristics of equipment relevant for assessing conformity with the requirements if applicable. - Time taken to automatically reach standby, or off mode, or another condition which does not exceed the applicable power consumption requirements. - If applicable, the technical justification shall be provided that the requirements are inappropriate for the intended use of equipment.		N/A

TEST REPORT

Annex II of EC NO 1275/2008			
Clause	Ecodesign requirements, 2nd stage (Apply as from January 7 th , 2013)	Result - Remark	Verdict
2a)	Power consumption in 'off mode': Power consumption of equipment in any off-mode condition shall not exceed 0,50 W	0.00W for DF-019A	Pass
2b)	Power consumption in 'standby mode(s)': The power consumption of equipment in any condition providing only a reactivation function, or providing only a reactivation function and a mere indication of enabled reactivation function, shall not exceed 0,50 W.		N/A
2b)	The power consumption of equipment in any condition providing only information or status display, or providing only a combination of reactivation function and information or status display shall not exceed 1,00 W.		N/A
2c)	Availability of off mode and/or standby mode Equipment shall, except where this is inappropriate for the intended use, provide off mode and/or standby mode, and/or another condition which does not exceed the applicable power consumption requirements for off mode and/or standby mode when the equipment is connected to the mains power source. - Characteristics of equipment relevant for assessing conformity with the requirements if applicable. - Time taken to automatically reach standby, or off mode, or another condition which does not exceed the applicable power consumption requirements. - If applicable, the technical justification shall be provided that the requirements are inappropriate for the intended use of equipment.	For DF-019A: Off mode provided. For DF-019: short period used appliance after heating user disconnects the product and stores it therefore no need for standby and or off-mode.	Pass

TEST REPORT

2d)	<p>Power management</p> <p>When equipment is not providing the main function, or when other energy-using product(s) are not dependent on its functions, equipment shall, unless inappropriate for the intended use, offer a power management function, or a similar function, that switches equipment after the shortest possible period of time appropriate for the intended use of the equipment, automatically into:</p> <ul style="list-style-type: none">— standby mode, or— off mode, or— another condition which does not exceed the applicable power consumption requirements for off mode and/or standby mode when the equipment is connected to the mains power source. The power management function shall be activated before delivery. <p>- Characteristics of equipment relevant for assessing conformity with the requirements if applicable.</p> <p>- Time taken to automatically reach standby, or off mode, or another condition which does not exceed the applicable power consumption requirements.</p> <p>- If applicable, the technical justification shall be provided that the requirements are inappropriate for the intended use of equipment.</p>	Replaced by EC No 801/2013	N/A
-----	--	----------------------------	-----

TEST REPORT

Annex II of EC NO 801/2013			
Clause	Ecodesign requirements, 2nd stage	Result - Remark	Verdict
2d)	<p>Power management for all equipment other than networked equipment (Apply as from January 1st, 2013):</p> <p>Equipment shall, unless inappropriate for the intended use, offer a power management function or a similar function. When equipment is not providing the main function, and other energy- using product(s) are not dependent on its functions, the power management function shall switch equipment after the shortest possible period of time appropriate for the intended use of the equipment, automatically into:</p> <ul style="list-style-type: none"> — standby mode, or — off mode, or — another condition which does not exceed the applicable power consumption requirements for off mode and/or standby mode when the equipment is connected to the mains power source. The power management function shall be activated <p>- Characteristics of equipment relevant for assessing conformity with the requirements if applicable.</p> <p>- Time taken to automatically reach standby, or off mode, or another condition which does not exceed the applicable power consumption requirements.</p> <p>- If applicable, the technical justification shall be provided that the requirements are inappropriate for the intended use of equipment.</p>		N/A
3	<p>For network equipment (Apply as from January 1st, 2015)</p>		–
3a)	<p>Possibility of deactivating wireless network connection(s)</p> <p>Any networked equipment that can be connected to a wireless network shall offer the user the possibility to deactivate the wireless network connection(s). This requirement does not apply to products which rely on a single wireless network connection for intended use and have no wired network connection.</p>		N/A

TEST REPORT

3b)	<p>Power management for networked equipment</p> <p>Equipment shall, unless inappropriate for the intended use, offer a power management function or a similar function. When equipment is not providing a main function, and other energy-using product(s) are not dependent on its functions, the power management function shall switch equipment after the shortest possible period of time appropriate for the intended use of the equipment, automatically into a condition having networked standby.</p> <p>In a condition providing networked standby, the power management function may switch equipment automatically into standby mode or off mode or another condition which does not exceed the applicable power consumption requirements for standby and/or off mode.</p> <p>The power management function, or a similar function, shall be available for all network ports of the networked equipment.</p> <p>The power management function, or a similar function, shall be activated, unless all network ports are deactivated. In that latter case the power management function, or a similar function, shall be activated if any of the network ports is activated.</p> <p>The default period of time after which the power management function, or a similar function, switches the equipment automatically into a condition providing networked standby shall not exceed 20 minutes.</p>		N/A
3c)	Networked equipment that has one or more standby modes shall comply with the requirements for these standby mode(s) when all network ports are deactivated.		N/A
3d)	Networked equipment other than HiNA equipment shall comply with the provisions under 2(d) when all network ports are deactivated.		N/A
3e)	Power consumption in a condition providing networked standby:		-
	The power consumption of HiNA equipment or equipment with HiNA functionality in a condition providing networked standby into which the equipment is switched by the power management function, or a similar function shall not exceed 12,00 W.		N/A

TEST REPORT

	The power consumption of other networked equipment in a condition providing networked standby into which the equipment is switched by the power management function, or a similar function, shall not exceed 6,00 W.		N/A
	The power consumption limits as stipulated in point (e) shall not apply to: (i) printing equipment with a power supply of a rated power larger than 750 W; (ii) large format printing equipment; (iii) tele-presence systems; (iv) desktop thin clients; (v) workstations; (vi) mobile workstations; (vii) small-scale servers; (viii) computer servers.		–
4	For network equipment, in addition to the requirements set out in point 3(a) and (b), the following provisions shall apply: (Apply as from January 1 st , 2017)		–
4a)	Networked equipment that has one or more standby mode(s) shall comply with the requirements for these standby mode(s) when all wired network ports are disconnected and when all wireless network ports are deactivated.		N/A
4b)	Networked equipment other than HiNA equipment shall comply with the provisions under 2(d) when all wired network ports are disconnected and when all wireless network ports are deactivated.		N/A
4c)	Power consumption in a condition providing “networked standby”:		–
	The power consumption of HiNA equipment or equipment with HiNA functionality, in a condition providing networked standby into which the equipment is switched by the power management function, or a similar function, shall not exceed 8,00 W.		N/A
	The power consumption of other networked equipment in a condition providing networked standby into which the equipment is switched by the power management function, or a similar function, shall not exceed 3,00 W.		N/A
	The power consumption limits as stipulated in point (c) shall not apply to: (i) large format printing equipment; (ii) desktop thin clients; (iii) workstations;		–

TEST REPORT

	(iv) mobile workstations; (v) small-scale servers; (vi) computer servers.	
5	For network equipment, in addition to the requirements set out in point 3(a) and (b) and point 4(a), (b) and (c), the following provision shall apply for networked equipment other than HiNA equipment or other than equipment with HiNA-functionality: (Apply as from January 1 st , 2019)	–
	The power consumption of networked equipment other than HiNA equipment or other than equipment with HiNA functionality, in a condition providing networked standby into which the equipment is switched by the power management function, or a similar function, shall not exceed 2,00 W.	N/A
6	For coffee machines, the delay time after which the product switches automatically into the modes and conditions referred to in Annex II, point 2, paragraph (d) shall be as follows: (Apply as from January 1 st , 2015)	–
	— for domestic drip filter coffee machines storing the coffee in an insulated jug, a maximum of five minutes after completion of the last brewing cycle or 30 minutes after completion of a descaling or self-cleaning process	N/A
	— for domestic drip filter coffee machines storing the coffee in a non-insulated jug, a maximum of 40 minutes after completion of the last brewing cycle, or 30 minutes after completion of a descaling or self-cleaning process	N/A
	— for domestic coffee machines other than drip filter coffee machines, a maximum of 30 minutes after completion of the last brewing cycle, or a maximum of 30 minutes after activation of the heating element, or a maximum of 60 minutes after activation of the cup preheating function, or a maximum of 30 minutes after completion of a descaling or self-cleaning process, unless an alarm has been triggered requiring users' intervention to prevent possible damage or accident.	N/A
	Until the above date the ecodesign requirements set out in Annex II.2.d shall not apply.	N/A
7	Product information requirements As of 1 January 2015, the following information for networked equipment shall be visibly displayed on manufacturers' freely accessible websites:	–

TEST REPORT

7a)	for each standby and/or off mode and the condition providing networked standby into which the equipment is switched by the power management function or similar function:		–
	– the power consumption data in Watt rounded to the first decimal place,		N/A
	– the period of time after which the power management function, or a similar function, switches the equipment automatically into standby and/or off mode and/or the condition providing networked standby;		N/A
7b)	the power consumption of the product in networked standby if all wired network ports are connected and all wireless network ports are activated;		N/A
7c)	guidance on how to activate and deactivate wireless network ports		N/A
	The power consumption of the product in networked standby as referred to in point (b) and the guidance as referred to in point (c) shall also be included in the user manual.		N/A
9	Information to be provided by manufacturers For the purposes of conformity assessment pursuant to Article 4, the technical documentation shall contain the following elements:		–
9a)	for each standby and/or off mode:		–
	– the power consumption data in Watt rounded to the first decimal place,		N/A
	– the measurement method used,		N/A
	– a description of how the equipment mode was selected or programmed		N/A
	– the sequence of events leading to the condition where the equipment automatically changes modes,		N/A
	– any notes regarding the operation of the equipment, e.g. information on how the user switches the equipment into a condition having networked standby		N/A
	– if applicable, the default time after which the power management function, or similar function, has switched the equipment into the applicable low power mode or condition;		N/A
9b)	for networked equipment:		–

TEST REPORT

	— the number and type of network ports and, with the exception of wireless network ports, where these ports are located on the equipment; in particular it shall be declared if the same physical network port accommodates two or more types of network ports,		N/A
	— whether all network ports are deactivated before delivery		N/A
	— whether the equipment qualifies as HiNA equipment or equipment with HiNa functionality; where no information is provided, this is considered not to be the case;		N/A
	and for each type of network port:		–
	— the default time after which the power management function, or a similar function, switches the equipment into a condition providing networked standby,		N/A
	— the trigger that is used to reactivate the equipment,		N/A
	— the (maximum) performance specifications,		N/A
	— the (maximum) power consumption of the equipment in a condition providing networked standby into which the power management function, or a similar function, will switch the equipment, if only this port is used for remote activation,		N/A
	— the communication protocol used by the equipment;		N/A
	If no information is provided, the equipment is considered not to be networked equipment unless it provides the functionalities of a router, network switch, wireless network access point (not being a terminal), hub, modem, VoIP telephone, video phone.		N/A
9c)	test parameters for measurements:		–
	— ambient temperature,		N/A
	— test voltage in V and frequency in Hz,		N/A
	— total harmonic distortion of the electricity supply system,		N/A
	— information and documentation on the instrumentation, set-up and circuits used for electrical		N/A

TEST REPORT

	testing;		
9d)	the equipment characteristics relevant for assessing conformity with the requirements set out in point 1(c), or the requirements set out in points 2(c) and/or 2(d) and/or 3(b), as applicable, including the time taken to automatically reach standby, or off mode, or another condition which does not exceed the applicable power consumption requirements for off mode and/or standby mode.		N/A
	In particular, if applicable, a technical justification shall be provided that the requirements set out in point 1(c), or the requirements set out in points 2(c) and/or 2(d) and/or 3(b), are inappropriate for the intended use of equipment. The need to maintain one or more network connections or to wait for a remotely initiated trigger is not considered a technical justification for exemption from the requirements set out in 2(d) in the case of equipment that is not defined as networked equipment by the manufacturer.';		N/A

TEST REPORT

Testing circuit

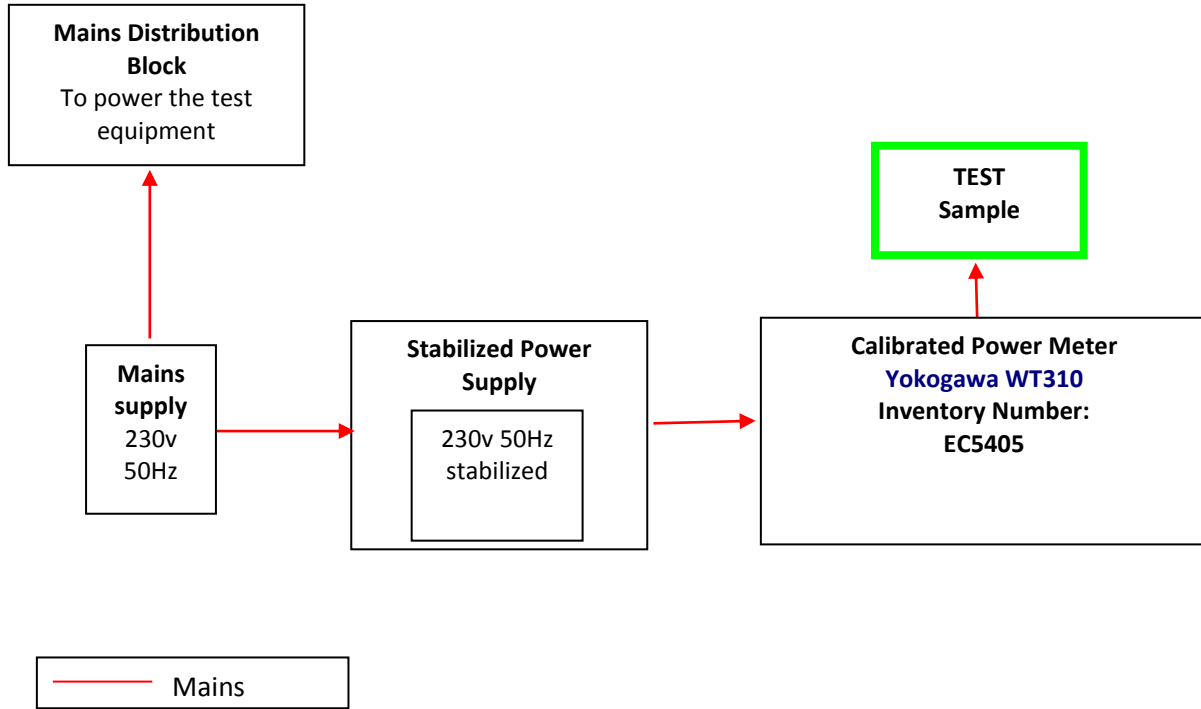

TEST REPORT

Photos of the appliance:

DF-019A of representative



DF-019



The results only relate to the item tested

Place
Shanghai

Date
7-December-2021

Name of laboratory
Intertek Testing Services Shanghai Limited.

Tested by:

Marvin Meng

Marvin Meng
Engineer

Approved by:

Jaki Pan

Jaki Pan
Reviewer